स्वचालित मापन प्रणालियों की निष्पादन लक्षण
भाग 5 स्थिर स्तोत्रों से उत्सर्जित फ्लू गैस में अमोनिया की
द्रव्यमान सांद्रता का निर्धारण

**Performance Characteristics of
Automated Measuring Systems
Part 5 Determination of the Mass
Concentration of Ammonia in Flue Gas
from Stationary Sources**

ICS No. 81.040.20

© BIS 2022



भारतीय मानक ब्यूरो
BUREAU OF INDIAN STANDARDS
मानक भवन, 9 बहादुर शाह ज़फर मार्ग, नई दिल्ली - 110002
MANAK BHAVAN, 9 BAHADUR SHAH ZAFAR MARG
NEW DELHI - 110002
www.bis.gov.in www.standardsbis.in

NATIONAL FOREWORD

This Indian Standard, which is identical with ISO 17179 “Stationary source emissions — Determination of the mass concentration of ammonia in flue gas — Performance characteristics of automated measuring systems” issued by the International Organization for Standardization (ISO), was adopted by the Bureau of Indian Standards on the recommendation of the Air Quality Sectional Committee and approval of the Chemical Division Council.

This standard has been published in several parts. Other parts of the standard are as follows:

Part 1 Carbon monoxide, carbon dioxide and oxygen from stationary sources

Part 2 Particulate Matter from Stationary Sources

Part 3 Sulfur Dioxide from Stationary Sources

Part 4 Nitrogen Oxides from Stationary Sources

The text of ISO Standard has been approved as suitable for publication as an Indian Standard without deviations. Certain conventions and terminologies are, however, not identical to those used in Indian Standards. Attention is particularly drawn to the following:

- a) Wherever the words ‘International Standard’ appear referring to this standard, they should be read as ‘Indian Standard’.
- b) Comma (,) has been used as a decimal marker in the International Standard, while in Indian Standards, the current practice is to use a point (.) as the decimal marker.

The technical committee has reviewed the provisions of the following International Standards referred in this standard and has decided that they are acceptable for use in conjugation with this standard:

<i>International Standard</i>	<i>Title</i>
ISO 9169	Air quality — Definition and determination of performance characteristics of an automatic measuring system
ISO 14956	Air quality — Evaluation of the suitability of a measurement procedure by comparison with a required measurement uncertainty
ISO 20988	Air quality — Guidelines for estimating measurement uncertainty

Conditioning and test atmospheres stipulated in this standard may not be applicable to tropical/subtropical countries like India. The applicable Standard Atmospheric Conditions (SAC) for Indian Conditions are $(27 \pm 2)^\circ\text{C}$ and (65 ± 5) percent relative humidity and may be observed while using this standard.

In reporting the result of a test or analysis made in accordance with this standard, if the final value, observed or calculated, is to be rounded off, it shall be done in accordance with IS 2 : 2022 ‘Rules for rounding off numerical values (*second revision*)’.

Indian Standard

PERFORMANCE CHARACTERISTICS OF AUTOMATED
MEASURING SYSTEMS

**PART 5 DETERMINATION OF THE MASS CONCENTRATION OF AMMONIA
IN FLUE GAS FROM STATIONERY SOURCES**

1 Scope

This International Standard specifies the fundamental structure and the most important performance characteristics of automated measuring systems for ammonia (NH₃) to be used on stationary source emissions, for example, combustion plants where SNCR/SCR NO_x control systems (deNO_x systems) are applied. The procedures to determine the performance characteristics are also specified. Furthermore, it describes methods and equipment to determine NH₃ in flue gases including the sampling system and sample gas conditioning system.

This International Standard describes extractive systems, based on direct and indirect measurement methods, and *in situ* systems, based on direct measurement methods, in connection with a range of analysers that operate using, for example, the following principles:

- ammonia conversion to, or reaction with NO, followed by chemiluminescence (CL) NO_x difference measurement for ammonia (differential NO_x);
- ammonia conversion to, or reaction with NO, followed by non-dispersive ultraviolet (NDUV) spectroscopy NO_x difference measurement for ammonia (differential NO_x);
- Fourier transform infrared (FTIR) spectroscopy;
- non-dispersive infrared (NDIR) spectroscopy with gas filter correlation (GFC);
- tuneable laser spectroscopy (TLS).

The method allows continuous monitoring with permanently installed measuring systems of NH₃ emissions, and is applicable to measurements of NH₃ in dry or wet flue gases, for process monitoring, long term monitoring of the performance of deNO_x systems and/or emission monitoring.

Other equivalent instrumental methods can be used, provided they meet the minimum requirements proposed in this International Standard. The measuring system can be calibrated with certified gases, in accordance with this International Standard, or comparable methods.

The differential NO_x technique using CL has been successfully tested on some power plants where the NO_x concentration and NH₃ concentration in flue gas after deNO_x systems are up to 50 mg (NO)/m³ and 10 mg (NH₃)/m³, respectively. AMS based on FTIR, NDIR with GFC and TLS has been used successfully in this application for measuring ranges as low as 10 mg (NH₃)/m³.

2 Normative references

The following documents, in whole or in part, are normatively referenced in this document and are indispensable for its application. For dated references, only the edition cited applies. For undated references, the latest edition of the referenced document (including any amendments) applies.

ISO 9169, *Air quality — Definition and determination of performance characteristics of an automatic measuring system*

ISO 14956, *Air quality — Evaluation of the suitability of a measurement procedure by comparison with a required measurement uncertainty*

ISO 20988, *Air quality — Guidelines for estimating measurement uncertainty*

3 Terms and definitions

For the purposes of this document, the following terms and definitions apply.

3.1 analyser

analytical part in an extractive or *in situ* AMS (3.3)

[SOURCE: ISO 12039:2001, 3.3]

3.2 automated measuring system AMS

measuring system interacting with the flue gas under investigation, returning an output signal proportional to the physical unit of the *measurand* (3.11) in unattended operation

Note 1 to entry: In the sense of this International Standard, an AMS is a system that can be attached to a duct or stack to continuously or intermittently measure the mass concentration of NH₃ passing through the duct.

[SOURCE: ISO 9169:2006, 2.1.2, modified.]

3.3 *in situ* AMS

non-extractive systems that measure the concentration directly in the duct or stack

Note 1 to entry: *In situ* systems measure either across the stack or duct or at a point within the duct or stack.

3.4 calibration of an automated measuring system

procedure for establishing the statistical relationship between values of the *measurand* (3.11) indicated by the *automated measuring system* (3.2) and the corresponding values given by an independent method of measurement implemented simultaneously at the same measuring point

3.5 efficiency of NH₃/NO

efficiency of a converter which oxidizes NH₃ to NO

3.6 efficiency of NH₃/N₂

efficiency of a converter which reduces NH₃ to N₂

3.7 influence quantity

quantity that is not the *measurand* (3.11) but that affects the result of the measurement

[SOURCE: ISO/IEC Guide 98-3:2008, B.2.10]

3.8 interference cross-sensitivity

negative or positive effect upon the response of the measuring system, due to a component of the sample that is not the *measurand* (3.11)

3.9 interferent interfering substance

substance present in the air mass under investigation, other than the *measurand* (3.11), that affects the response

[SOURCE: ISO 9169:2006, 2.1.12]

3.10
lack-of-fit

systematic deviation within the range of application between the measurement results obtained by applying the calibration function to the observed response of the measuring system, measuring *reference materials* (3.16) and the corresponding accepted value of such reference materials

Note 1 to entry: Lack of-fit may be a function of the measurement result.

Note 2 to entry: The expression “lack-of-fit” is often replaced in everyday language for linear relations by “linearity” or “deviation from linearity”.

[SOURCE: ISO 9169:2006, 2.2.9, modified.]

3.11
measurand

particular quantity subject to measurement

[SOURCE: ISO/IEC Guide 98-3:2008, B.2.9, modified.]

3.12
NO₂/NO converter efficiency

efficiency with which the converter unit of a NO_x analyser reduces NO₂ to NO

3.13
performance characteristic

one of the quantities assigned to equipment in order to define its performance

Note 1 to entry: Performance characteristics can be described by values, tolerances, or ranges.

3.14
period of unattended operation

maximum interval of time for which the *performance characteristics* (3.13) remain within a predefined range without external servicing, e.g. refill, adjustment

Note 1 to entry: The period of unattended operation is often called maintenance interval.

[SOURCE: ISO 9169:2006, 2.2.11]

3.15
reference gas

gaseous mixture of stable composition used to calibrate the measuring system and which is traceable to national or international standards

3.16
reference material
RM

substance or mixture of substances with a known concentration within specified limits, or a device of known characteristics

Note 1 to entry: Normally used are calibration gases, gas cells, gratings, or filters.

[SOURCE: ISO 14385-1:2014, 3.20]

3.17
reference method

measurement method taken as a reference by convention, which gives the accepted reference value of the *measurand* (3.11)

3.18
transport time in the measuring system

time period for transportation of the sampled gas from the inlet of the probe to the inlet of the measurement instrument

3.19

response time

time interval between the instant when a stimulus is subjected to a specified abrupt change and the instant when the response reaches and remains within specified limits around its final stable value, determined as the sum of the lag time and the rise time in the rising mode, and the sum of the lag time and the fall time in the falling mode

Note 1 to entry: Lag time, rise time and fall time are defined in ISO 9169:2006.

[SOURCE: ISO 9169:2006, 2.2.4]

3.20

span gas

gas or gas mixture used to adjust and check the *span point* (3.21) on the response line of the measuring system

Note 1 to entry: This concentration is often chosen around 70 % to 80 % of full scale.

3.21

span point

value of the output quantity (measured signal) of the *automated measuring system* (3.2) for the purpose of calibration, adjustment, etc. that represents a correct measured value generated by *reference material* (3.16)

3.22

standard uncertainty

uncertainty (3.23) of the result of a measurement expressed as a standard deviation

[SOURCE: ISO/IEC Guide 98-3:2008, 2.3.1]

3.23

uncertainty (of measurement)

parameter, associated with the result of a measurement, that characterizes the dispersion of the values that could reasonably be attributed to the *measurand* (3.11)

[SOURCE: ISO/IEC Guide 98-3:2008, 2.2.3]

3.24

validation of an automated measuring system

procedure to check the statistical relationship between values of the *measurand* (3.11) indicated by the *automated measuring system* (3.2) and the corresponding values given by an independent method of measurement implemented simultaneously at the same measuring point

3.25

zero gas

gas or gas mixture used to establish the *zero point* (3.26) on a calibration curve within a given concentration range

[SOURCE: ISO 12039:2001, 3.4.2]

3.26

zero point

specified value of the output quantity (measured signal) of the *AMS* (3.2) and which, in the absence of the measured component, represents the zero crossing of the calibration line

4 Symbols and abbreviated terms

e_i	Residual (lack-of-fit) at level i
k	Coverage factor
n	Number of measurements
s_r	Standard deviation of repeatability
$u(\gamma_{\text{NH}_3})$	Combined uncertainty of NH_3 mass concentration
$U(\gamma_{\text{NH}_3})$	Expanded uncertainty of NH_3 mass concentration
M_c	Molar mass of NH_3 (=17,031 g/mol)
V_M	Molar volume (22,4 l/mol)
ϕ_{NH_3}	Volume fraction of NH_3
γ_{NH_3}	NH_3 mass concentration in mg/m^3
γ_S	NH_3 mass concentration at standard conditions in mg/m^3 (273,15 K; 101,325 kPa)
γ_R	NH_3 mass concentration at reference conditions in mg/m^3 (273,15 K; 101,325 kPa; O_2 and H_2O corrected)
\bar{x}	Average of the measured values x_i
x_i	i th measured value
\bar{x}_i	Average of the measured value at level i
\hat{x}_i	Value estimated by the regression line at level i
AMS	Automated measuring system
CL	Chemiluminescence
FTIR	Fourier transform infrared
GFC	Gas filter correlation
NDIR	Non-dispersive infrared
NDUV	Non-dispersive ultraviolet
QA	Quality assurance
QC	Quality control
SCR	Selective catalytic reduction
SNCR	Selective non-catalytic reduction
TLS	Tuneable laser spectroscopy

5 Principle

This International Standard describes automated measurement systems for sampling, sample conditioning, and determining NH₃ content in flue gas using instrumental methods (analysers).

There are two types of automated measuring systems:

- extractive systems;
- *in situ* systems.

With extractive systems, the representative gas sample is taken from the stack with a sampling probe and conveyed to the analyser through the sampling line and sample gas conditioning system.

In situ systems do not require any sample processing. For the installation of these systems, a representative place in the stack is to be chosen.

The systems described in this International Standard measure NH₃ concentration using instrumental methods that shall meet the minimum performance specifications given.

6 Description of the automated measuring systems

6.1 Sampling and sample gas conditioning systems

Since ammonia (NH₃) is condensable and highly reactive component, there are many opportunities for loss of sample integrity due to condensation, deposition or other loss of ammonium compounds in the sample transport system.

The details of the sampling and sample gas conditioning systems for each of automated measuring systems are described in [Annex A](#), [Annex B](#), and [Annex C](#).

6.2 Analyser equipment

Examples of the typical analytical methods available are described in [Annex A](#) (NO/NO_x CL technique and NDUV technique), [Annex B](#) (FTIR and NDIR with GFC technique) and [Annex C](#) (TLS technique).

Instruments that use these techniques shall meet the performance characteristics as described in [Clause 7](#).

7 Performance characteristics

7.1 Performance criteria

[Table 1](#) gives the performance characteristics and performance criteria of the analyser and measurement system to be evaluated during general performance test, by means of ongoing QA/QC in the laboratory and during field operation. Test procedures for the performance test are specified in [Annex E](#).

Table 1 — Main performance characteristics and criteria of AMS for measurement of ammonia

Performance characteristic	Performance criterion	Test procedure
Response time	≤ 400 s ^a ≤ 900 s ^b	E.2
Standard deviation of repeatability in laboratory at zero point	≤ 2 % of the upper limit of the lowest measuring range used	E.3.2
Standard deviation of repeatability (NH ₃) in laboratory at span point	≤ 2 % of the upper limit of the lowest measuring range used	E.3.3
Lack-of-fit	$\leq \pm 2$ % of the upper limit of the lowest measuring range used	E.4
Zero drift within 24 h	$\leq \pm 2$ % of the upper limit of the lowest measuring range used	E.10
Span drift within 24 h	$\leq \pm 2$ % of the upper limit of the lowest measuring range used	E.10
Sensitivity to sample gas pressure, for a pressure change of 2 kPa	$\leq \pm 3$ % of the upper limit of the lowest measuring range used	E.13
Zero drift within the period of unattended operation	$\leq \pm 3$ % of the upper limit of the lowest measuring range used	E.11
Span drift within the period of unattended operation	$\leq \pm 3$ % of the upper limit of the lowest measuring range used	E.11
Sensitivity to ambient temperature, for a change of 10 K in the temperature range specified by the manufacturer	$\leq \pm 3$ % of the upper limit of the lowest measuring range used	E.14
Sensitivity to electric voltage in the voltage range specified by the manufacturer	$\leq \pm 2$ % of the upper limit of the lowest measuring range used per 10 V ^c	E.15
Cross-sensitivity	≤ 4 % of the upper limit of the lowest measuring range used	E.5
NO ₂ /NO converter efficiency, if applicable	≥ 95 %	E.6
NH ₃ /NO converter efficiency, if applicable	≥ 90 %	E.7
NH ₃ /N ₂ converter efficiency, if applicable	≥ 95 %	E.7
Losses and leakage in the sampling line and conditioning system	≤ 2 % of the measured value	E.8 for losses and E.9 for leakage
Excursion of the measurement beam of cross-stack <i>in situ</i> AMS	≤ 2 % of the measured value of the lowest measuring range used	E.12
<p>^a For emission monitoring from deNO_x systems.</p> <p>^b For long term monitoring of changes in the deNO_x systems, especially the reduction of catalyst activity.</p> <p>^c In the case of a nominal supply voltage of 200 V.</p>		

The measuring range is defined by two values of the measurand, or quantity to be supplied, within which the limits of uncertainty of the measuring instrument are specified. The upper limit of the lowest measuring range used should be set suitable to the application, such that the measurement values lie within 20 % to 80 % of the measuring range.

7.2 Determination of the performance characteristics

7.2.1 Performance test

The performance characteristics of the AMS shall be determined during the general performance test. The values of the performance characteristics determined shall meet the performance criteria specified in [Table 1](#). The procedures for the determination of these performance characteristics are described in [Annex E](#).

The ambient conditions applied during the general performance test shall be documented.

The measurement uncertainty of the AMS measured values shall be calculated in accordance with ISO 14956 on the basis of the performance characteristics determined during the general performance test and shall meet the level of uncertainty appropriate for the intended use.

7.2.2 Ongoing quality control

The user shall check specific performance characteristics during ongoing operation of the measuring system with a periodicity specified in [Table 2](#).

The measurement uncertainty during field application shall be determined by the user of the measuring system in accordance with applicable international or national standards. For process monitoring (non-regulatory application), the level of uncertainty shall be appropriate for the intended use. It can be determined by a direct or an indirect approach for uncertainty estimation as described in ISO 20988. The uncertainty of the measured values under field operation is not only influenced by the performance characteristics of the analyser itself but also by uncertainty contributions due to

- the sampling line and conditioning system,
- the site specific conditions, and
- the calibration gases used.

8 Measurement procedure

8.1 General

The AMS shall be operated according to the manufacturer's instructions.

The QA/QC procedures specified in [Clause 9](#) shall be strictly observed.

During the measurement, the ambient conditions should be in the ranges applied during the general performance test.

8.2 Choice of the measuring system

To choose an appropriate analyser, sampling line and conditioning unit, the following characteristics of flue gases should be known before the field operation:

- ambient temperature range;
- temperature of the flue gas;
- water vapour content of the flue gas;
- dust load of the flue gas;
- expected concentration range of NH₃;
- expected concentration of potentially interfering substances.

To avoid long response times and memory effects, the sampling line should be as short as possible. If necessary, a bypass pump should be used. If there is a high dust loading in the sample gas, an appropriate heated filter shall be used.

Before monitoring emissions, the user shall verify that the necessary QA/QC procedures have been performed.

NOTE Information on QA/QC procedures is provided in ISO 14385-1[3] and ISO 14385-2.[4]

8.3 Sampling

8.3.1 Sampling location

The sampling location shall be an available space for the sampling equipment, analyser and possible sampling platform requirements and construction, making a representative emission measurement possible and is suitable for the measurement task. In addition, the sampling location shall be chosen with regard to safety of the personnel, accessibility and availability of electrical power.

8.3.2 Sampling point(s)

It is necessary to ensure that the gas concentrations measured are representative of the average conditions inside the flue gas duct. Therefore, the sampling points shall be selected to allow for a representative sampling.

NOTE The selection of sampling points for representative sampling is described, e.g. in ISO 10396, where gas stratification, fluctuations in gas velocity, temperature and others are mentioned.

8.4 Data collection

The values measured with the calibrated AMS at operating conditions of the flue gas shall be recorded by an internal or external data logging system and averaged in accordance with the measurement task.

The volume content of water vapour in the flue gas (if necessary) should also be measured in parallel and averaged over the sampling period of the NH₃ measurement to express the NH₃ concentrations for dry flue gas conditions.

8.5 Calculation

Results of the measurement shall be expressed as mass concentrations at reference conditions.

If the NH₃ concentration is provided as a volume concentration, [Formula \(1\)](#) shall be used to convert volume fraction of NH₃ (10⁻⁶), ϕ_{NH_3} , to NH₃ mass concentrations, γ_{NH_3} :

$$\gamma_{\text{NH}_3} = \phi_{\text{NH}_3} \cdot \frac{M_c}{V_M} \quad (1)$$

where

- γ_{NH_3} is the NH₃ mass concentration in mg/m³;
- ϕ_{NH_3} is the volume fraction of NH₃ (by volume, 10⁻⁶);
- M_c is the molar mass of NH₃ (=17,031 g/mol);
- V_M is the molar volume (=22,4 l/mol).

The NH₃ concentration measured in the wet gas shall be corrected to the NH₃ concentration at standard conditions, using [Formula \(2\)](#):

$$\gamma_S = \gamma_{\text{NH}_3} \cdot \frac{t}{273,15} \cdot \frac{101,325}{101,325 + p} \quad (2)$$

where

- γ_{NH_3} is the NH₃ mass concentration measured in the wet gas (mg/m³);
- γ_S is the NH₃ mass concentration at standard conditions in mg/m³ (273,15 K; 101,325 kPa);
- t is the temperature (K);
- p is the difference between the static pressure of the sample gas and the standard pressure (kPa).

If necessary, the NH₃ concentration measured in the wet gas should be corrected to the NH₃ concentration at reference conditions, using [Formula \(3\)](#):

$$\gamma_R = \gamma_{\text{NH}_3} \cdot \frac{t}{273,15} \cdot \frac{101,325}{101,325 + p} \cdot \frac{100\%}{100\% - h} \quad (3)$$

where

- γ_{NH_3} is the NH₃ mass concentration measured in the wet gas (mg/m³);
- γ_R is the NH₃ mass concentration at reference conditions in mg/m³ (273,15 K; 101,325 kPa; O₂ and H₂O corrected);
- t is the temperature (K);
- p is the difference between the static pressure of the sample gas and the standard pressure (kPa);
- h is the absolute water vapour content (by volume) (%).

9 Quality assurance and quality control procedures

9.1 General

Quality assurance and quality control (QA/QC) are important in order to ensure that the uncertainty of the measured values for NH₃ is kept within the limits specified for the measurement task.

9.2 Frequency of checks

AMS shall be adjusted and checked after the installation and then during continuous operation. [Table 2](#) shows the minimum required test procedures and frequency of checks. The user shall implement the relevant procedures for determination of performance characteristics or procedures described in this subclause and [Annex E](#). The results of the QA/QC procedures shall be documented.

Table 2 — Minimum checks and minimum frequency of checks for QA/QC during the operation

Check	Minimum frequency	Test procedure
Response time	Once a year	E.2
Standard deviation of repeatability at zero point	Once a year	E.3.2
Standard deviation of repeatability (NH ₃) at span point	Once a year	E.3.3
Lack-of-fit	Once a year	E.4
Sampling system and leakage check	Once a year	E.8, E.9
Beam alignment (<i>in situ</i> AMS only)	Once a year	E.12
Light intensity attenuation through cleanliness and dust load (<i>in situ</i> AMS only)	Continuous basically	According to manufacturer's requirements

Table 2 (continued)

Check	Minimum frequency	Test procedure
Cleaning or changing of particulate filters at the sampling inlet and at the monitor inlet	The particulate filters shall be changed periodically depending on the dust load at the sampling site. During this filter change, the filter housing shall be cleaned.	According to manufacturer's requirements
NO ₂ /NO converter efficiency (if applicable)	According to manufacturer's recommendations	E.6
NH ₃ /N ₂ converter efficiency (if applicable)	According to manufacturer's recommendations	E.7
NH ₃ /NO converter efficiency (if applicable)	According to manufacturers' recommendations	E.7
Zero drift	Once in the period of unattended operation or period specified by national standard	E.11
Span drift	Once in the period of unattended operation or period specified by national standard	E.11
Regular maintenance of the analyser	According to manufacturer's recommendations	According to manufacturer's requirements
Calibration and validation of the analyser	According to national or international standards	9.3

The user shall implement a procedure to guarantee that the reference materials used meet the uncertainty requirement specified in [Annex D](#), e.g. by comparison with a reference gas of higher quality.

9.3 Calibration, validation and measurement uncertainty

Permanently installed AMS for continuous monitoring shall be calibrated and validated by comparison with an independent method of measurement. The validation shall include the determination of the uncertainty of the measured values obtained by the calibrated AMS.

The AMS shall be subject to adjustments and functional tests according to [9.2](#) before each calibration and validation.

The calibration and validation of the AMS shall be performed at regular intervals and after repair of the analyser in accordance with applicable national or international standards.

The uncertainty of measured values obtained by permanently installed AMS for continuous monitoring shall be determined by comparison measurements with an independent method of measurement as part of the calibration and validation of the AMS. This ensures that the measurement uncertainty is representative of the application at the specific plant.

NOTE The determination of the uncertainty of measured values obtained by permanently installed AMS for continuous monitoring on the basis of a comparison with an independent method of measurement is described, e.g. in ISO 20988.

The uncertainty of the measured values shall meet the uncertainty criterion specified for the measurement objective.

10 Test report

The test report shall be in accordance with international or national regulations. If not specified otherwise, it shall include at least the following information:

- a) a reference to this International Standard, i.e. ISO 17179;
- b) a description of the measurement objective;

- c) the principle of gas sampling;
- d) an information about the analyser and description of the sampling and conditioning line;
- e) the identification of the analyser used, and the performance characteristics of the analyser, listed in [Table 1](#);
- f) the operating range;
- g) the sample gas temperature, sample gas pressure and optical path length through an optical cell (it is needed for only *in situ* measurement);
- h) the details of the quality and the concentration of the span gases used;
- i) a description of plant and process;
- j) the identification of the sampling plane;
- k) the actions taken to achieve representative samples;
- l) a description of the location of the sampling point(s) in the sampling plane;
- m) a description of the operating conditions of the plant process;
- n) the changes in the plant operations during sampling;
- o) the sampling date, time and duration;
- p) the time averaging on relevant periods;
- q) the measured values;
- r) the measurement uncertainty;
- s) the results of any checks;
- t) any deviations from this International Standard.

Annex A (informative)

Extractive differential NO_x measurement technique

A.1 Measuring principle based on differential NO_x technique

The analysis principle is based upon a differential NO_x technique; whereby NH₃ in flue gas is converted to NO or N₂ before the gas is entering an NO/NO_x analyser and the NH₃ signal is obtained by difference from a separate, total NO_x measurement.

The following conversions are possible:

- a) conversion of NH₃ to N₂: measurement of difference between NO_x and (NO_x - NH₃);
- b) conversion of NH₃ to NO: measurement of difference between NO_x and (NO_x + NH₃).

As an analyser for NO, a chemiluminescence (CL) analyser, a non-dispersive ultraviolet (NDUV) analyser or all other suitable NO analyser can be used.

Ammonia levels are determined by comparing the NH₃ + NO_x measurement with a NO_x measurement without NH₃ conversion conducted in parallel. Ammonia concentration is determined by the difference between the measurement values.

A.2 Description of the automated measuring system

A.2.1 General

A representative volume of flue gas is extracted from the emission source for a fixed period of time at a controlled flow rate. Dust present in the volume sampled is removed by filtration before the sample gas is conditioned and passes to the analytical instrument. [Figure A.1](#) shows a typical arrangement of a complete measuring system for NH₃.

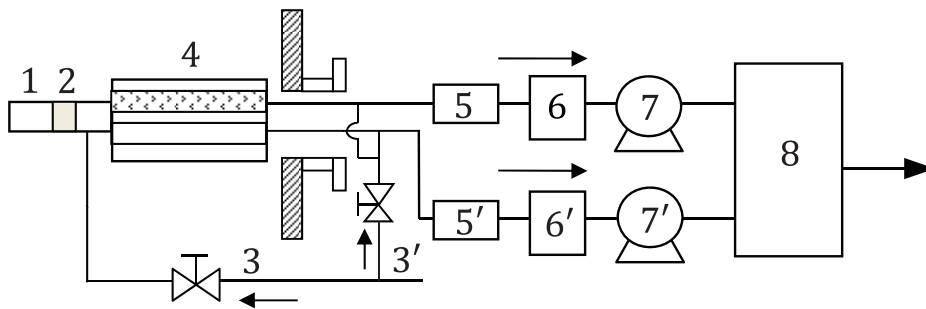

Key

- 1 sampling probe, heated (if necessary)
- 2 particle filter (in-stack or out-stack)
- 3, 3' zero and span gas inlet
- 4 NH₃ converter (NH₃/N₂ converter or NH₃/NO converter; in-stack or out-stack)
- 5, 5' NO₂/NO converter
- 6, 6' moisture removal system
- 7, 7' pump
- 8 NO/NO_x analyser (one analyser or two separate analysers)

Figure A.1 — Diagram of the measuring system (example)

A.2.2 Components of the sampling and the sample gas conditioning systems

A.2.2.1 Sampling probe

The sampling probe shall be made of suitable, corrosion-resistant material (e.g. stainless steel without Mo, borosilicate glass, ceramic; PTFE is only suitable for flue gas temperature lower than 200 °C). At temperatures greater than 250 °C, stainless steel containing Mo can convert NH₃ to NO. Any materials made from copper or copper-based alloys are not to be used.

A.2.2.2 Filter

The filter is needed to remove the particulate matter, in order to protect the sampling system and the analyser. The filter shall be made of ceramic, PTFE, borosilicate glass or sintered metal. The filter shall be heated above the water or acid dew-point. A filter that retains particles greater than 2 µm is recommended. The size of the filter shall be determined from the sample flow required and the manufacturer's data on the flow rate per unit area.

The temperature of the sampling probe and the filter is considered higher than the water or acid dew-point, since the sampling point is usually chosen after the outlet of deNO_x systems.

A.2.2.3 NH₃ converter

Depending on the used process, there are two options for the conversion of NH₃.

A.2.2.3.1 Converter of NH₃ to NO

The catalytic converter (e.g. consisting of precious metals, such as platinum) operates at about 700 °C and converts NH₃ to NO according to the following reaction:

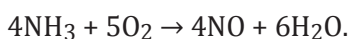

A.2.2.3.2 Converter of NH₃ to N₂

The converter contains a catalyst similar to that for deNO_x processes. It works around 250 °C to 350 °C and converts NH₃ to N₂ according to the following reaction:



When the converter of NH₃ to N₂ is used, the concentration of NO in the flue gas shall be higher than that of NH₃.

A.2.2.4 Sampling line

The sampling line shall be made of PTFE, PFA or stainless steel without Mo, e.g. 304 SS. The lines shall be operated at 15 °C above the dew-point of condensable substances (generally the water or acid dew-point). The tube diameter should be appropriately sized to provide a flow rate that meets the requirements of the analysers, under selected line length and the degree of pressure drop in the line, as well as the performance of the sampling pump used.

A.2.2.5 NO_x converter

NO₂/NO converter: The converter shall consist of a heated furnace maintained at a constant temperature and is made of material such as stainless steel, tungsten, spectroscopically pure carbon or quartz. It shall be capable of converting at least 95 % of NO₂ to NO.

A.2.2.6 Moisture removal system

The moisture removal system shall be used to separate water vapour from the flue gas. The dew-point shall be sufficiently below the ambient temperature. A relative humidity equivalent to a cooling temperature of 2 °C to 5 °C is suggested. Sufficient cooling is required for the volume of gas being sampled and the amount of water vapour that it contains.

A.2.2.7 Sampling pump

A sampling pump is used to withdraw a continuous sample from the duct through the sampling system. This may be a diaphragm pump, a metal bellows pump, an ejector pump or other pumps. The pump shall be constructed of corrosion-resistant material. The performance of the pump shall be such that it can supply the analyser with the gas flow required. In order to reduce the transport time in the sampling line and the risk of physicochemical transformation of the sample, the gas flow can be greater than that required for the analytical units.

A.2.2.8 Flow controller and flow meter

The flow controller and flow meter are used to set the required flow. They shall be constructed of corrosion-resistant material. As an alternative, a negative pressure flow control without contact to measuring gas shall be used.

A.2.3 NO_x analyser

A.2.3.1 General

One analyser or two different analysers may be used for the measurement of NO, CL, NDUV or any other suitable NO analyser may be used.

NOTE The measurement uncertainty using two different analysers is likely to be larger than that using one analyser.

A.2.3.2 Chemiluminescent analyser

The CL analyser typically consists of the following principal components:

- ozone generator;
- reaction chamber;
- optical filter;
- photodetector or photodiode detector;
- ozone removal device.

A.2.3.3 NDUV analyser

The NDUV analyser typically consists of the following principal components:

- light source;
- optical and/or gas filters;
- measurement cell;
- photodetector;
- calibration cell to be used for QC drift check.

Annex B (informative)

Extractive direct NH₃ measurement technique

B.1 Measuring principle based on extractive direct NH₃ measurement

The analysis principle is based on a hot and extractive measurement of NH₃ based on optical spectrometers. Usually, a spectral range at around 1,000 cm⁻¹ is used. Fourier transform infrared (FTIR) spectrometers or NDIR photometers with gas filter correlation (GFC) can be used for this purpose. For the correction to dry standard conditions, it is recommended to measure water vapour together with the NH₃ concentration in one instrument.

B.2 Description of the automated measuring system

B.2.1 General

A representative volume of flue gas is extracted from the emission source at a controlled flow rate. Particulate matter present in the volume sampled is removed by filtration before the sample passes to the analytical instrument. [Figure B.1](#) shows a typical arrangement of a complete measuring system for NH₃ based on a direct and hot NH₃ measurement.

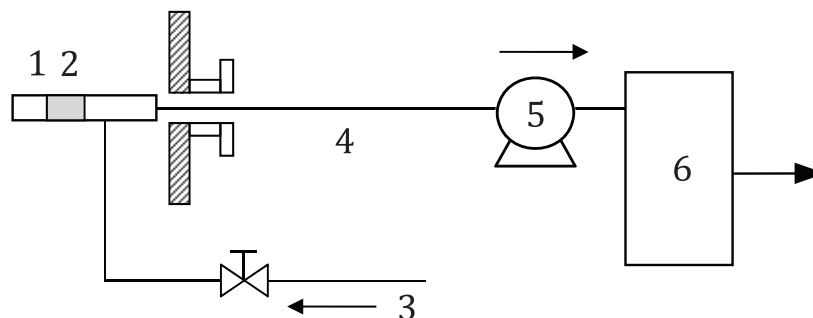

Key

- 1 sampling probe, heated (if necessary)
- 2 particle filter (in-stack or out-stack)
- 3 zero and span gas inlet
- 4 heated sample line
- 5 pump, heated
- 6 analyser with heated sample cell

Figure B.1 — Diagram of the hot optical measuring system (example)

B.2.2 Components of the sampling and the sample gas conditioning systems

B.2.2.1 Sampling probe

The sampling probe shall be made of suitable, corrosion-resistant material (e.g. stainless steel without Mo, borosilicate glass, ceramic; PTFE is only suitable for flue gas temperature lower than 200 °C). At temperatures higher than 250 °C, stainless steel containing Mo can convert NH₃ to NO. Any materials made from copper or copper based alloys are not to be used.

B.2.2.2 Filter

The filter is needed to remove the particulate matter, in order to protect the sampling system and the analyser. The filter shall be made of ceramic, PTFE, borosilicate glass or sintered metal. The filter shall be heated above the water or acid dew-point. A filter that retains particles greater than 2 µm is recommended. The size of the filter shall be determined from the sample flow required and the manufacturer's data on the flow rate per unit area.

The temperature of the sampling probe and the filter is considered higher than the water or acid dew-point, since the sampling point is usually chosen after the outlet of deNO_x system.

B.2.2.3 Sampling line

The sampling line shall be made of PTFE, PFA or stainless steel without Mo, e.g. 304 SS. The lines shall be operated at a minimum 180 °C. The tube diameter should be appropriately sized to provide a flow rate that meets the requirements of the analysers, under selected line length and the degree of pressure drop in the line, as well as the performance of the sampling pump used.

B.2.2.4 Sampling pump

A sampling pump is used to withdraw a continuous sample from the duct through the sampling system. The pump can be located in front or after the hot ammonia analyser. The pump may be a diaphragm pump, a metal bellows pump, an ejector pump or other pumps. The pump shall be constructed of corrosion-resistant material and shall be operated at a minimum of 180 °C. The performance of the pump shall be such that it can supply the analyser with the gas flow required. In order to reduce the transport time in the sampling line and the risk of physicochemical transformation of the sample, the gas flow can be greater than that required for the analytical units.

B.2.2.5 Flow controller and flow meter

The flow controller and flow meter are used to set the required flow. They shall be constructed of corrosion-resistant material. As an alternative, a negative pressure flow control without contact to measuring gas shall be used.

B.2.2.6 NH₃ analyser

B.2.2.6.1 General

As an analyser used for the hot extractive NH₃ measurement, an FTIR analyser, NDIR with GFC analyser or all other suitable NH₃ analyser can be used.

B.2.2.6.2 FTIR NH₃ analyser

The FTIR analyser typically consists of the following principal components:

- light source;
- interferometer;
- measuring cell heated to a minimum of 180 °C;
- detector.

B.2.2.6.3 NDIR with GFC analyser

The NDIR with GFC analyser typically consists of the following principal components:

- light source;

- gas filters;
- chopper wheel;
- measuring cell heated to a minimum of 180 °C;
- detector.

Annex C (informative)

In situ and direct NH₃ measurement with TLS analyser

C.1 Measuring principle based on *in situ* and direct NH₃ measurement with TLS analyser

The analysis principle is based upon an *in situ* measurement of unconditioned NH₃ in the stream. Ammonia levels are determined by direct measurement with a tuneable laser analyser or any other suitable NH₃ analyser can be used. For the correction to dry standard conditions, it is recommended to measure water vapour together with the NH₃ concentration.

C.2 *In situ* cross duct measuring systems

C.2.1 General

The *in situ* TLS measuring system consists of a transmitter and receiver unit. The two units are mounted opposite each other directly on the pipe or stack. [Figure C.1](#) shows a typical arrangement of an *in situ* measuring system based on tuneable laser for NH₃.

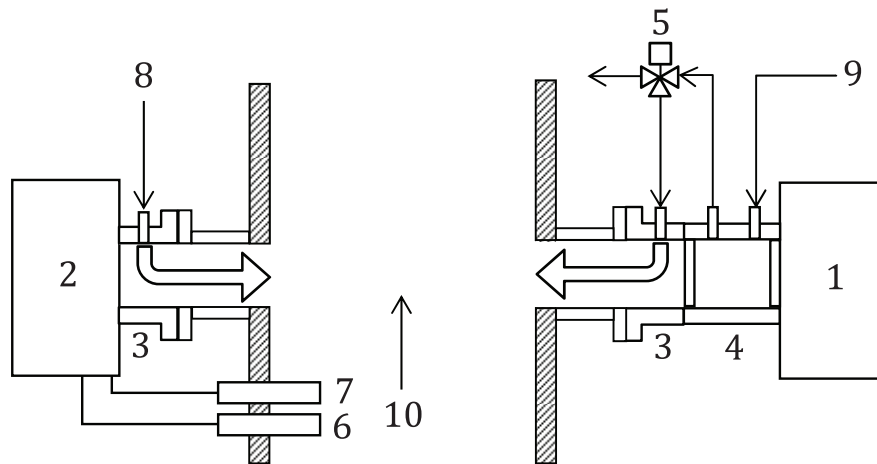

Key

- 1 transmitter unit
- 2 receiver unit
- 3 purging flanges
- 4 validation cell
- 5 three-way valve
- 6 pressure sensor (if the duct has constant conditions, it is not required)
- 7 temperature sensor (if the duct has constant conditions, it is not required)
- 8 purge gas
- 9 purge gas, span gas or zero gas
- 10 stack gas region

Figure C.1 — Diagram of an *in situ* TLS measuring system (example)

C.2.2 Components of an *in situ* TLS measuring system (cross duct)

C.2.2.1 Transmitter and receiver unit

The transmitter unit contains a laser light source and the receiver unit contains a photo detector. The light beam is emitted from laser diode located in the transmitter unit. The laser light passes through the gas and strikes the photo detector in the receiver unit.

C.2.2.2 Optical window purge

The purging flanges have two functions. First, the flanges are used to mount the transmitter or receiver unit on the pipe. Second, the purging flange has a connection port for the purging.

If required by the application, purge gas is applied to keep the windows clean in order to prevent the contamination of the optical components by the flue gas. The purge medium enters the purging flange and flows in the direction of the duct, where it is mixed with the flue gas. As purge medium, usually instrument air is used. The purge flow depends on the conditions and is typically between 20 l/min and 50 l/min.

C.2.2.3 Validation cell

To verify the functionality of the TLS measuring system, a validation procedure can be conducted regularly.

One method for validation is to apply an external validation cell, which is permanently mounted in the optical path between the pipe and the transmitter/receiver unit. An alternative method is to use a gas-filled cell with stable concentration.

During the validation procedure, the validation cell is flushed with certified test gas or gas-filled validation cell is temporarily moved into the optical path respectively.

The gas concentration required for both methods depends on the optical path length and validation cell, as well as the measuring range. Typically, test gas with a concentration equivalent to 70 % to 80 % of full span is used.

C.2.2.4 Pressure and temperature sensor

Due to the *in situ* installation, varying gas pressures and gas temperatures in flue gas may have an effect on the measurement signal. If the parameters exceed the maximum acceptable variations, pressure and/or temperature sensors can be applied to provide the relevant gas pressure or temperature to the TLS measuring system to correct for the influence of temperature and pressure variations.

C.3 *In situ* point measuring systems

C.3.1 General

The *in situ* point measuring system consists of a transceiver unit and a probe. The beam is typically transmitted through a short path of sample gas stream and reflected by the corner cube (mirror) at the tip of the probe. [Figure C.2](#) shows a typical arrangement of an *in situ* point measuring system

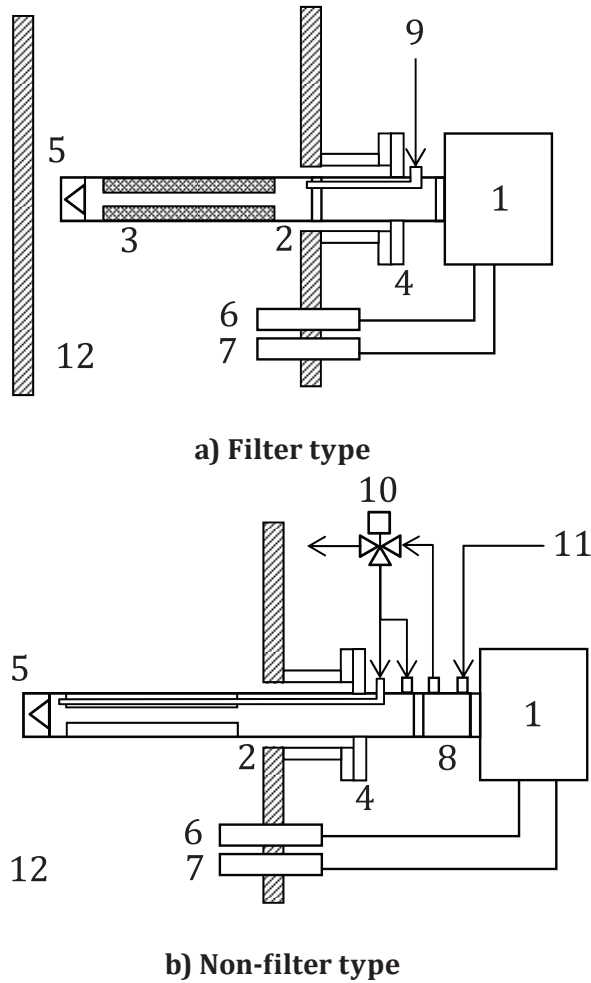

Key

- 1 transceiver unit
- 2 probe
- 3 probe filters
- 4 probe flange
- 5 corner cube (mirror)
- 6 pressure sensor (if the duct has constant conditions, it is not required)
- 7 temperature sensor (if the duct has constant conditions, it is not required)
- 8 validation cell
- 9 span gas or zero gas
- 10 three-way valve
- 11 purge gas, span gas or zero gas
- 12 stack gas region

Figure C.2 — Example of an *in situ* TLS measuring system (point monitor)

C.3.2 Components of an *in situ* TLS measuring system (point monitor)

C.3.2.1 General

In situ point monitors sample the gas stream in the duct at the end of the probe. Gas is typically monitored over a short path, depending upon the principle of measurement (see [Figure C.2](#)).

C.3.2.2 Instrument transceiver

The component senses the response of the measurement cell and generates an electrical signal that corresponds to the concentration of the gas being measured.

C.3.2.3 Measurement cell

A cell or cavity is exposed to the gas stream, for the purpose of producing an electro-optical response to the gas concentration at the end of the probe.

C.3.2.4 Probe filter

A porous ceramic or sintered metal tube or screen minimizes the interference of particulate matter with the gas measurement. If little effect of particulate matter on the measurement is expected, it is possible to use a non-filter probe.

Annex D (normative)

Operational gases

D.1 General

Several operational gases are required when using this International Standard.

D.2 Operational gases for the measurement system using differential NO_x technique

D.2.1 Zero gas for NO/NO_x analyser

The zero gas shall consist of synthetic air or nitrogen. The NH₃ content shall not exceed 1,0 % of the upper limit of the measuring range used.

D.2.2 Zero gas for NH₃ analyser

The zero gas shall consist of a certain amount of NO in nitrogen for using a converter of NH₃ to N₂. For using a convertor of NH₃ to NO, nitrogen without NO as the zero gas can be used. The NH₃ content should not exceed 1,0 % of the upper limit of the measuring range used.

D.2.3 Span gas for NO/NO_x analyser

The span gas shall consist of NO in nitrogen. The NO concentration of the span gas should be about 70 % to 80 % of the selected measuring range for the NO/NO_x analyser.

D.2.4 Span gas for NH₃ analyser

The span gas shall consist of NH₃, NO and O₂ in nitrogen for using a converter of NH₃ to N₂ or NH₃. O₂ in nitrogen as the span gas can be used for using a convertor of NH₃ to NO. Each of cylinder gases for NH₃ and NO are mixed with an appropriate volume ratio to prepare the span gas. The NO concentration and the NH₃ concentration of the span gas should be about 50 % to 60 % and 20 % to 30 % of the selected measuring range for the NO/NO_x analyser, respectively. The O₂ concentration is about approximately 1 vol% to 20 vol% in the span gas. When using the NH₃/N₂ converter, the concentration of NO shall be higher than that of NH₃.

D.2.5 Reference gas

Reference gases of NH₃ and NO shall have a known concentration with a maximum permissible expanded uncertainty of 1,0 % of its nominal value traceable to national standards.

The reference gas concentration as the total NO_x should be about 70 % to 80 % of the selected measuring range for NO/NO_x analyser.

D.2.6 Test gas for checking the efficiency of NO₂/NO converter

Test gas for checking the converter efficiency shall consist of NO₂ in synthetic air. The concentration shall be in the range of the NO/NO_x concentration expected.

D.2.7 Test gas for checking the efficiency of NH₃/NO or NH₃/N₂ converter

Test gas for checking the converter efficiency shall consist of NH₃, NO and O₂ in nitrogen. The concentration shall be in the range of about twice the NH₃ concentration expected. When the NH₃/N₂ converter is used, the concentration of NO shall be higher than that of NH₃.

D.3 Operational gases for the measurement system based on both *in situ* and direct extractive NH₃ measurement technique

D.3.1 Zero gas for NH₃ analyser

The zero gas shall consist of nitrogen or ambient air. The NH₃ content should not exceed 1,0 % of the upper limit of the measuring range used. Dry or wet zero gas may be used.

D.3.2 Span gas for NH₃ analyser

The span gas shall consist of NH₃ in nitrogen. The NH₃ concentration of the span gas should be about 70 % to 80 % of the selected measuring range for the NH₃ analyser. Dry or wet span may be used.

D.3.3 Reference gas

Reference gases of NH₃ shall have a known concentration with a maximum permissible expanded uncertainty of 1,0 % of its nominal value traceable to national standards. Dry or wet reference gas may be used.

Annex E (normative)

Procedures for determination of the performance characteristics during the general performance test

E.1 General

Before any tests are being performed, the warm-up time specified by the manufacturer shall be taken into account. If the warm-up time is not specified, a minimum of 2 h should be taken.

Before determining the performance characteristics of an AMS, the instrument shall be set up according to the manufacturer's requirements and according to the procedure detailed in [9.2](#).

During the test conditions for each individual performance characteristic, the values of the following parameters shall be constant within the specified range stated below:

- surrounding temperature ± 2 °C;
- sampling pressure $\pm 0,2$ kPa;
- supply voltage ± 1 % of the nominal line voltage (except for the voltage dependence test).

For the determination of the various performance characteristics, reference gases with a known uncertainty of concentration shall be used.

Response time, repeatability at zero and at span level, linearity check, cross-sensitivity, zero drift and span drift, sensitivity to ambient temperature, sensitivity to electric voltage of *in situ* systems may be measured with an external test cell. Specific care must be taken, e.g. cell should be heated and surface should be treated to avoid losses of ammonia.

E.2 Response time

In order to establish response time, lag time, rise time and fall time, a step function of the measurand shall be input to the continuous automatic measuring system. Unless otherwise specified in the terms of reference, the step produced by the test facility shall have a rise time (between 10 % and 90 % of the step change) less than 10 % of the averaging time to be applied during the tests. The step change of the test facility shall correspond to at least 60 % of the measuring range (see [Figure E.1](#)). If rise time and fall time differ, the longer one is to be taken for the computation of the response time.

For instruments where transient oscillations occur in approach to the final output signal, the final output signal is considered as reached when the oscillations fall to within 10 % of the input step.

NOTE A significant difference between the rise time and the fall time indicates memory effects, i.e. dependence of a result of measurement on the values of the measurand during previous measurement(s).

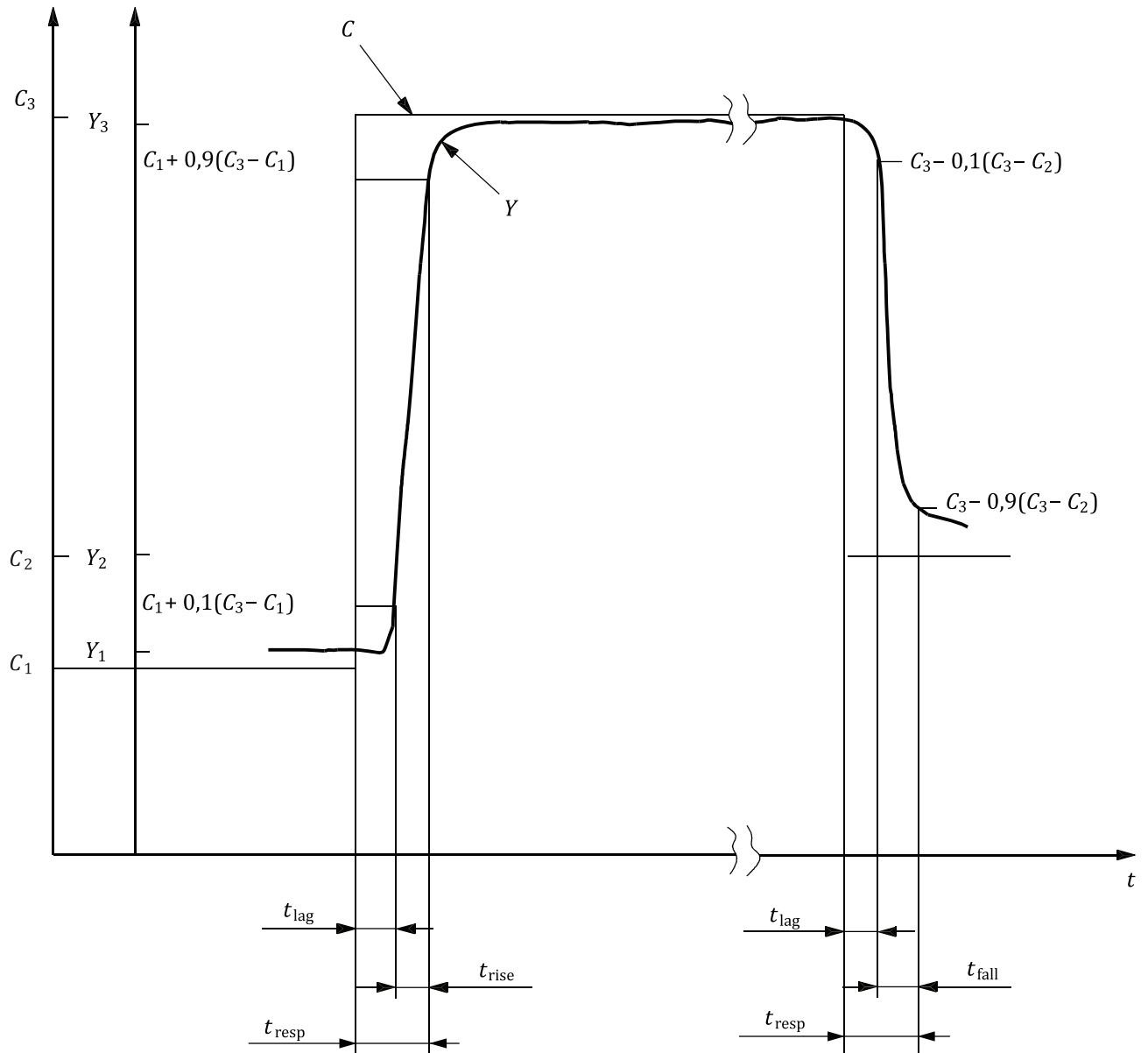

Key

- C_i value of the measurand in reference material i
- Y_i output signal obtained by measuring the measurand in reference material i
- t_{lag} lag time
- t_{rise} rise time
- t_{fall} fall time
- t_{resp} response time

NOTE Change of the output signal Y (output) after a change of the reference value C (input) as a function of time t .

Figure E.1 — Illustration of the time characteristics of an automated measuring system

E.3 Repeatability at zero and at span level

E.3.1 General

To determine repeatability at zero and at span level, several measurements are conducted at zero and at a span concentration according to the procedures in [E.3.2](#) and in [E.3.3](#). Standard deviation and repeatability are calculated for both series of measurement (zero and span value) according to ISO 9169.

E.3.2 Standard deviation of repeatability in laboratory at zero point

The standard deviation of repeatability at zero point shall be determined by application of a reference material at the zero point (zero gas). First, adjust the zero point of the analyser. Then zero gas shall be applied at the zero and span gas inlet.

If the standard deviation of repeatability at zero point is determined during the lack-of-fit test, the reference material at zero concentration applied during the test shall be used.

The measured values of the AMS at zero point shall be determined after application of the reference material by waiting the time equivalent to one independent reading, and then put in a zero gas or go back to flue gas, and then measure span gas, at least 10 times to 20 times.

The measured values obtained shall be used to determine the standard deviation of repeatability at zero point using [Formula \(E.1\)](#):

$$s_r = \sqrt{\frac{\sum (x_i - \bar{x})^2}{n - 1}} \quad (\text{E.1})$$

where

- s_r is the standard deviation of repeatability;
- x_i is the i th measured value;
- \bar{x} is the average of the measured values x_i ;
- n is the number of measurements.

The standard deviation of repeatability at zero point shall meet the performance criterion specified in [Table 1](#).

E.3.3 Standard deviation of repeatability in laboratory at span point

The standard deviation of repeatability at span point shall be determined by application of a reference material at the span point (span gas). The span gas shall be applied at the zero and span gas inlet. If the standard deviation of repeatability at span point is determined during the lack-of-fit test, the highest value of reference material applied during the test shall be used.

The measured values of the AMS at span point shall be determined after application of the reference material by waiting the time equivalent to one independent reading, and then put in a zero gas or go back to flue gas, and then measure span gas, at least more than 3 times. The measured signals obtained shall be used to determine the standard deviation of repeatability at span using [Formula \(E.1\)](#).

The standard deviation of repeatability at span point shall meet the performance criterion specified in [Table 1](#).

E.4 Lack-of-fit (linearity)

The lack-of-fit (linearity) shall be checked in the laboratory by feeding zero gas and at least four test gases with concentrations evenly distributed over the selected measuring range. The different gas concentrations may be produced using a dilution system.

The test gases shall be applied in an order, which avoids hysteresis effects.

Perform for each test gas with the accepted value, c_i , at least three consecutive measurements, each averaged over at least one response time. The residuals, e_i (lack-of-fit), shall be determined on the basis of a linear regression as described in ISO 9169. In this test procedure, a regression line is established between the instrument readings of the AMS (x values) and the test gas values (c values). In the next step, the average \bar{x}_i of AMS readings at each test gas level is calculated. Then the deviation (residual) of the average to the corresponding value, \hat{x}_i , estimated by the regression line is calculated according to [Formula \(E.2\)](#):

$$e_i = |\hat{x}_i - \bar{x}_i| \quad (\text{E.2})$$

The deviations, e_i , at each test gas concentration shall meet the performance criterion specified in [Table 1](#).

If the performance criterion is not met, the instrument response shall be corrected until the performance criterion is met.

E.5 Cross-sensitivity

The influence of potentially interfering substances also present in the flue gas shall be determined by admitting test gas mixtures to the input of the complete AMS (upstream of the test gas cooler, where present). The gas mixtures shall be produced with a mixing system in which an interferent is added to the gases for zero point and span point. The mixing system shall be compliant with national standards and shall have a maximum expanded uncertainty of 1 %. Reference materials (e.g. gases) shall be certified (traceable to national standards) and shall have an expanded uncertainty no greater than 2 %.

Interferents and their concentrations are defined in relation to the measuring principle and the intended measurement objective. The interferents listed in [Table E.1](#) shall be examined. The interferents shall be admitted individually.

Test gas without interferent and then with the interferent shall be applied. The measured signals of the AMS shall be determined for each test gas by waiting the time equivalent to one independent reading and then recording three consecutive individual readings. The three individual readings shall be averaged.

The deviations between the average reading with and the average reading without the interferent present at the zero point and span point shall be determined for each interferent.

All positive deviations above 0,5 % of the span gas concentration shall be summed and all negative deviations below -0,5 % of the span gas concentration shall be summed at both the zero point and span point. The maximum of the absolute values of the four summations shall meet the performance criteria specified in [Table 1](#).

The individual readings, averages and deviations at zero point and span point and for all interferents, as well as the maximum deviation, shall be reported.)

Table E.1 — Concentrations of interferences used during cross sensitivity tests

Interferent	Mass or volume concentration	
	Value	Unit
O ₂	3 ^a and 21	%
H ₂ O	30	%
CO	300	mg/m ³
CO ₂	15	%
CH ₄	50	mg/m ³
N ₂ O	20	mg/m ³
N ₂ O (fluidised-bed firing)	100	mg/m ³
NO	300	mg/m ³
NO ₂	30	mg/m ³
NH ₃	20	mg/m ³
SO ₂	200	mg/m ³
SO ₂ (coal-fired power stations without desulphurisation)	1 000	mg/m ³
HCl	50	mg/m ³
HCl (coal-fired power stations)	200	mg/m ³

^a A test with 3 % oxygen concentration is used instead of a test without interferent.

E.6 Check of the efficiency of NO₂/NO converter

For analysers with two reaction chambers, adjust the NO_x analyser on the NO and NO_x channel with a NO concentration around the emission limit value. Make sure that both channels give the same value and record the values.

Apply a NO₂ containing gas with a known concentration (as mentioned in [D.2.6](#)) to the analyser.

Record the NO_x and NO concentration. Wait at least 6 response times between the readings of the NO_x and NO concentrations. A measurement shall be taken as the average of a time period of at least 3 response times.

Calculate the converter efficiency by [Formula \(E.3\)](#):

$$Conv.Eff.(%) = \frac{(NO_x)_u - (NO)_u}{(NO_2)_i} \times 100 \quad (E.3)$$

where

Conv. Eff. (%) is the converter efficiency in percentage;

$(NO_x)_u$ is the NO_x reading with NO₂ containing gas;

$(NO)_u$ is the NO reading with NO₂ containing gas;

$(NO_2)_i$ is the NO₂ concentration of the NO₂ containing gas applied to the analyser.

Perform the determination of the converter efficiency 3 times and report the average of the three determinations. The value of the efficiency shall meet the performance criterion specified in [Table 1](#).

E.7 Check of the efficiency of NH₃/NO or NH₃/N₂ converter

The test gas described in [D.2.7](#) shall be applied at the zero and span gas inlet. Record the NH₃ concentration. Calculate the converter efficiency by [Formula \(E.4\)](#):

$$\text{Conv. Eff. (\%)} = (\text{NH}_3 \text{ reading with the test gas}) / (\text{NH}_3 \text{ concentration in the test gas}) \times 100 \quad (\text{E.4})$$

E.8 Check of losses in the sampling line and conditioning system

The losses in the sampling line and conditioning system shall be checked by supplying zero gas and span gas to the analyser through the sampling system, as close as possible to the nozzle (in front of the filter if possible), and secondly, direct to the analyser. The test gas should have a NH₃ concentration of about 70 % to 80 % of the measuring range. For the AMS of extractive differential NO_x technique, zero gas (see [D.2.1](#)) and span gas (see [D.2.3](#)) shall be used, since NH₃ in flue gas is converted to NO or N₂ by NH₃ converters and the gas only containing NO passes through the sampling line to NO_x analyser. Possible impurities in the entire system may lead to memory effects due to adsorption or desorption to or from the surfaces. Differences shall be less than 2 %.

E.9 Check of leakage in the sampling line and conditioning system

The sampling system shall be checked for leaks. The procedure of leak test is as follows.

- Assemble the complete sampling system, including charging the filter housing and absorbers.
- Allow the sampler to warm up to its operating temperature.
- Seal the nozzle inlet.
- Close the nozzle and switch on the pump(s).
- After reaching minimum pressure, read the flow rate.

E.10 Zero drift and span drift for performance test

Zero and span drifts are estimated by applying at least 10 sequences of zero and span level, evenly distributed on a period of 24 h, and calculating for each concentration the slope of a linear regression, according to ISO 9169.

The position of the zero point and of the span point shall be determined manually by feeding zero gas and span gas. The deviations between the measured values at the zero point and at the span point and the nominal values shall meet the performance criterion specified in [Table 1](#).

E.11 Zero drift and span drift for periodical test

Instrument adjustments with zero and span gases or with other reference materials shall be carried out at least once in the period of unattended operation. Tests for instruments for periodical measurements shall be carried out at the beginning of each measurement series.

The zero and span gas or other reference materials shall be used under the same flow and pressure conditions as for measurement conditions. For zero and span gas, the sample port of the instrument or a procedure according to the manufacturer's instructions should be used. The deviations between the measured values at the zero point and at the span point and the nominal values shall meet the performance criterion specified in [Table 1](#).

E.12 Excursion of measurement beam of cross-stack *in situ* AMS

The test laboratory shall gradually and precisely deflect the transmitter and receiver assemblies of the AMS in the horizontal and vertical planes, and then record the measured signals using reference materials.

NOTE This test typically applies to cross-stack *in situ* optical techniques. The test also applies to extractive AMS with separate transmitter and receiver assemblies.

This testing requires calibration standards (e.g. reference filters) and an optical bench.

Typically, the experimental path length for this test can be from 1 m up to 5 m at least, although the test should be performed at the maximum path length practical.

Deflections shall be carried out for both the position of the zero point and for that of a span point for approximately 70 % to 90 % of the output range over two typical measurement path lengths. The deflection is to be performed in incremental steps of approximately 0,05° in the angle range demanded.

The range of deflection shall be equal to at least twice the angle specified by the manufacturer. It should also be tested as far as the deflection limit permitted by the assemblies — if necessary, in larger increments.

The efficiency of any manual optical adjustment facilities shall be examined at least in qualitative terms. Automatic adjustment processes shall be activated and included in the test.

The measured signals obtained for the various test steps shall be included in tabular form in the test report. These measured signals shall be paired up with the deflection angles.

The maximum permissible deflection angles shall be stated within which the AMS satisfies the performance criterion. In the case of automatically aligning AMS, the manner of operation shall be described and verified by means of test results.

E.13 Sensitivity to sample gas pressure, for a pressure change of 2 kPa

The test laboratory shall determine the influence of variations in sample gas pressure on the response of the AMS. The sample shall be nitrogen containing the measured component at a concentration of between 70 % and 80 % of the upper limit of the certification range.

The test laboratory shall measure the output signal of the AMS when the sample gas pressure is at

- the ambient atmospheric pressure,
- approximately 2 kPa above ambient atmospheric pressure, within limits of $\pm 0,2$ kPa, and
- approximately 2 kPa below ambient atmospheric pressure, within limits of $\pm 0,2$ kPa.

During the measurement period the temperature shall be held stable to within ± 1 K.

The measured signals of the AMS shall be determined at each pressure by waiting the time equivalent to one independent reading and then recording three consecutive individual readings. The three individual readings shall be averaged.

The deviations between the average reading at each pressure and the average reading at the ambient atmospheric pressure shall be determined. The deviations shall meet the applicable performance criteria specified in [Table 1](#). The individual readings, averages and deviations at each pressure, as well as the maximum deviation, shall be reported.

E.14 Sensitivity to ambient temperature, for a change of 10 K in the temperature range specified by the manufacturer

The test laboratory shall determine how the zero and span values of the AMS are influenced by changes in ambient temperature by using a climatic chamber which can control ambient temperature from $-20\text{ }^{\circ}\text{C}$ to $+50\text{ }^{\circ}\text{C}$, within limits of $\pm 1,0\text{ K}$.

In the case of AMS installed outdoors, the following temperatures shall be set in the climatic chamber in the given order of sequence:

$20\text{ }^{\circ}\text{C} \rightarrow 0\text{ }^{\circ}\text{C} \rightarrow -20\text{ }^{\circ}\text{C} \rightarrow 20\text{ }^{\circ}\text{C} \rightarrow 50\text{ }^{\circ}\text{C} \rightarrow 20\text{ }^{\circ}\text{C}$.

In the case of AMS installed at temperature-controlled locations, the following temperatures shall be set in the given order of sequence:

$20\text{ }^{\circ}\text{C} \rightarrow 5\text{ }^{\circ}\text{C} \rightarrow 20\text{ }^{\circ}\text{C} \rightarrow 40\text{ }^{\circ}\text{C} \rightarrow 20\text{ }^{\circ}\text{C}$.

After a sufficient equilibration period, the measured signals of the AMS at zero point and at span point shall be determined at each temperature by waiting the time equivalent to one independent reading and then recording three consecutive individual readings. The three individual readings shall be averaged.

The test laboratory shall wait at least 6 h between each temperature change in the environmental chamber, to allow the AMS to equilibrate, before taking further readings.

Alternatively, the test laboratory may monitor the reading from the AMS, following each temperature change. If the instrument stabilizes in less than 6 h, then the test laboratory may reduce the equilibration period. However, the test laboratory shall record objective and verifiable evidence to support this.

The AMS shall remain switched on when varying the ambient temperature in the environmental chamber.

The deviations between the average reading at each temperature and the average reading at $20\text{ }^{\circ}\text{C}$ shall be determined. The deviations shall meet the applicable performance criteria specified in [Table 1](#) for all temperatures. The test shall be repeated 3 times at the zero point and 3 times at the span point. If the AMS meets the performance criterion by a factor of two or more for the first test, then any subsequent testing may be omitted.

The individual readings, averages and deviations at each temperature, as well as the maximum deviation at zero point and at span point, shall be reported.

E.15 Sensitivity to electric voltage

The supply voltage to the AMS shall be varied, using an isolating transformer, in steps of 5 % from the nominal supply voltage to at least the upper and the lower limits specified by the manufacturer. The measured signals of the AMS at zero point and at span point shall be determined at each voltage by waiting the time equivalent to one independent reading and then recording three consecutive individual readings. The three individual readings shall be averaged.

After changes in voltage, the AMS can need time to stabilize. The deviations between the average reading at each voltage and the average reading at the nominal supply voltage shall be determined.

The deviations shall meet the applicable performance criteria specified in [Table 1](#) for all voltages. This test shall be repeated 3 times at the zero point and 3 times at the span point. If the AMS meets the performance criterion by a factor of two or more for the first test, then any subsequent testing may be omitted.

The individual readings, averages and deviations at each voltage, as well as the maximum deviation at zero point and at span point, shall be reported.

Annex F (informative)

Examples of the results for the assessment of ammonia AMS

The results of performance tests according to performance characteristics of [Annex E](#) for the differential NO_x method are given in [Table F.1](#).

The results of performance tests according to performance characteristics of [Annex E](#) for the direct measurements methods of ammonia are given in [Table F.2](#).

Table F.1 — Performance characteristics for indirect NH₃ measurement by differential NO_x methods

Performance characteristic	Performance criterion	Results of laboratory test	
		NH ₃ /NO ^a converter indirect extractive	NH ₃ /N ₂ converter indirect extractive
Typical lowest range		15 mg/m ³	15 mg/m ³
Response time	≤900 s	180 s	900 s
Standard deviation of repeatability in laboratory at zero point	≤2 % of the upper limit of the lowest measuring range used	1,0 %	1,0 %
Standard deviation of repeatability (NH ₃) in laboratory at span point	≤2 % of the upper limit of the lowest measuring range used	0,7 %	0,6 %
Lack-of-fit	≤ ±2 % of the upper limit of the lowest measuring range used	1,0 %	2,0 %
Zero drift within 24 h	≤ ±2 % of the upper limit of the lowest measuring range used	0 %	1,0 %
Span drift within 24 h	≤ ±2 % of the upper limit of the lowest measuring range used	1,0 %	0 %
Sensitivity to sample gas pressure, for a pressure change of 2 kPa	≤ ±3 % of the upper limit of the lowest measuring range used	0,1 %	0,1 %
Sensitivity to ambient temperature, for a change of 10 K	≤ ±3 % of the upper limit of the lowest measuring range used	-1,0 %	-1,0 %
Sensitivity to electric voltage	≤ ±2 % of the range per 10V	-0,3 %	-0,3 %
Cross-sensitivity ^b	≤4 % of the upper limit of the range used	-2,4 %	-2,4 %
NO ₂ /NO converter efficiency	≥95 %	95 %	95 %
NH ₃ /NO converter efficiency	≥90 %	90 %	—
NH ₃ /N ₂ converter efficiency	≥95 %	—	95 %
^a A span gas containing 70 mg/m ³ of NO shall be used for ongoing QA/QC test in the laboratory.			
^b See E.5 .			

Table F.2 — Performance characteristics for direct ammonia measurement methods

Performance characteristic	Performance criterion	Results of field and laboratory test		
		FTIR	NDIR with GFC	TLS
		Direct extractive		Direct <i>in situ</i>
Typical lowest range		15 mg/m ³	20 mg/m ³	10 mg/m ³
Response time	≤400 s	140 s	167 s	2 s
Standard deviation of repeatability in laboratory at zero point	≤2 % of the upper limit of the lowest measuring range used	1,1 %	0,3 %	0,1 %
Standard deviation of repeatability (NH ₃) in laboratory at span point	≤2 % of the upper limit of the lowest measuring range used	0,9 %	0,8 %	0,0 %
Lack-of-fit	≤ ±2 % of the upper limit of the lowest measuring range used	1,2 %	-0,9 %	1,0 %
Zero drift within 24 h	≤ ±2 % of the upper limit of the lowest measuring range used	1,2 % (6 months)	0 % (3 months)	0,5 % (6 months)
Span drift within 24 h	≤ ±2 % of the upper limit of the lowest measuring range used	3 % ^a (6 months) ^a	1,2 % (3 months)	-1,3 % (6 months)
Sensitivity to sample gas pressure, for a pressure change of 2 kPa	≤ ±3 % of the upper limit of the lowest measuring range used	No influence	No influence	No influence
Sensitivity to ambient temperature, for a change of 10 K	≤ ±3 % of the upper limit of the lowest measuring range used	2,5 %	0,9 %	1,0 %
Sensitivity to electric voltage	≤ ±2 % of the range per 10 V	-0,5 %	No influence	1,7 %
Cross-sensitivity	≤4 % of the upper limit of the measuring range used	2,4 %	0,7 %	1,8 %

^a Uncertainty calculation in the EN 15267 certification scheme is based on the drift within the maintenance period, which is 6 months in the above example. The 24 h drift for the extractive FTIR method is much lower and usually ≤ ±0,1 %.

Annex G (informative)

Calculation of uncertainty of measurement of NH₃

G.1 General

The model equations in this Clause, as well as calculations of partial uncertainties, are related to the values measured by the analyser and expressed in mg/m³. Explanation and calculation procedures for the standard uncertainty associated with measurement are given in ISO 20988.

G.2 Results of uncertainty calculation

The quantification of the impact of selected performance characteristics as partial standard uncertainty is calculated in accordance with ISO 14956.

Table G.1 — Results of uncertainty calculation for the differential NO_x method based on results from laboratory tests^a

Performance characteristic	Partial standard uncertainty	Value of standard uncertainty at upper limit of the lowest measuring range used (mg/m ³)	
		NH ₃ /NO converter	NH ₃ /N ₂ converter
Standard deviation of repeatability in laboratory at zero	$u_{r,0}$	0,15	0,15
Standard deviation of repeatability in laboratory at span level	$u_{r,s}$	0,11	0,09
Lack-of-fit	u_{lof}	0,15	0,30
Zero drift 24 h	$u_{d,0}$	0,00	0,15
Span drift 24 h	$u_{d,s}$	0,15	0,00
Sensitivity to sample gas pressure, for a pressure change of 2 kPa	$u_{inf,p}$	0,01	0,01
Sensitivity to ambient temperature, for a change of 10 K	$u_{inf,T}$	0,00	0,00
Sensitivity to electric voltage	$u_{inf,V}$	-0,01	-0,01
Cross-sensitivity	u_{i,CO_2}	-0,27	-0,27
Uncertainty of reference gas	u_{adj}	0,09	0,09
^a The following are the conditions of the laboratory test: <ul style="list-style-type: none"> — temperature during adjustment, 298 K; — fluctuation of ambient temperature during measurement, from 296 K to 300 K; — voltage variation, ±2 V at 100 V; — atmospheric pressure variation, <0,5 kPa; — influence of CO₂ (1 000 mg/m³), <4 %. 			

Combined standard uncertainty, $u(\gamma_{\text{NH}_3})$, and expanded uncertainty, $U(\gamma_{\text{NH}_3})$, are calculated as follows:

$$u(\gamma_{\text{NH}_3}) = \sqrt{u_{r,0}^2 + u_{r,s}^2 + u_{lof}^2 + u_{d,0}^2 + u_{d,s}^2 + u_{inf,p}^2 + u_{inf,T}^2 + u_{inf,V}^2 + u_{i,CO_2}^2 + u_{adj}^2} \quad (\text{G.1})$$

$$U(\gamma_{\text{NH}_3}) = k \cdot u(\gamma_{\text{NH}_3}) = 1,96u(\gamma_{\text{NH}_3}) \quad (\text{G.2})$$

where k is the coverage factor (=1,96).

Values of standard uncertainty at upper limit of the lowest measuring range used for both NH_3/NO converter and NH_3/N_2 converter are $0,40\text{mg}/\text{m}^3$ and $0,47\text{ mg}/\text{m}^3$, respectively. For the expanded uncertainties, values of both converters are $0,78\text{ mg}/\text{m}^3$ (5 % of the range) and $0,92\text{ mg}/\text{m}^3$ (6 % of the range), respectively.

Table G.2 — Results of uncertainty calculation for a typical extractive direct NH_3 measurement by FTIR based on results from field and laboratory tests

Performance characteristic	Partial standard uncertainty	Value of standard uncertainty at upper limit of the lowest measuring range used (mg/m^3)
Lack-of-fit	u_{lof}	0,18
Zero drift from field test	$u_{d,0}$	0,18
Span drift from field test	$u_{d,s}$	0,45
Influence of ambient temperature at span	$u_{inf,T}$	0,56
Influence of sample pressure	$u_{inf,p}$	0,00
Influence of sample gas flow	$u_{inf,f}$	0,00
Influence of supply voltage	$u_{inf,V}$	-0,08
Cross sensitivity	u_i	-0,74
Repeatability standard deviation at span	$u_{r,s}$	0,13
Uncertainty of the reference material	u_{adj}	0,21
Excursion of measurement beam	u_E	Not applicable
Converter efficiency for AMS measuring NO_x	$u_{conv.}$	Not applicable
Variation of response factors	$u_{var.}$	Not applicable

Test results have been taken from laboratory and field tests according to EN 15267.

Combined standard uncertainty and expanded uncertainty are calculated for the lowest measuring range of $15\text{ mg}/\text{m}^3\text{ NH}_3$ as follows.

Combined standard uncertainty:

$$u(\gamma_{\text{NH}_3}) = 0,6\text{ mg}/\text{m}^3$$

Expanded uncertainty:

$$U(\gamma_{\text{NH}_3}) = k \cdot u(\gamma_{\text{NH}_3}) = 1,96u(\gamma_{\text{NH}_3}) = 1,25\text{ mg}/\text{m}^3$$

Table G.3 — Results of uncertainty calculation for a typical direct *in situ* NH₃ measurement by TLS based on results from field and laboratory tests

Performance characteristic	Partial standard uncertainty	Value of standard uncertainty at upper limit of the lowest measuring range used (mg/m ³)
Lack-of-fit	u_{lof}	-0,20
Zero drift from field test	$u_{d,0}$	0,00
Span drift from field test	$u_{d,s}$	0,00
Influence of ambient temperature at span	$u_{inf,T}$	0,20
Influence of sample pressure	$u_{inf,p}$	0,00
Influence of sample gas flow	$u_{inf,f}$	0,00
Influence of supply voltage	$u_{inf,V}$	-0,10
Influence of interferents (cross sensitivity)	u_i	0,15
Repeatability standard deviation at span	$u_{r,s}$	0,20
Uncertainty of the reference material	u_{adj}	0,14
Excursion of measurement beam	u_E	0,12
Converter efficiency for AMS measuring NO _x	$u_{conv.}$	Not applicable
Variation of response factors	$u_{var.}$	Not applicable

Test results have been taken from laboratory and field tests according to EN 15267.

Combined standard uncertainty and expanded uncertainty are calculated for the lowest measuring range of 10 mg/m³ NH₃ as follows.

Combined standard uncertainty:

$$u(\gamma_{NH_3}) = \sqrt{u_{r,0}^2 + u_{r,s}^2 + u_{lof}^2 + u_{d,0}^2 + u_{d,s}^2 + u_{inf,p}^2 + u_{inf,T}^2 + u_{inf,V}^2 + u_{i,CO_2}^2 + u_{adj}^2}$$

$$= 0,43 \text{ mg/m}^3$$

Expanded uncertainty:

$$U(\gamma_{NH_3}) = k \cdot u(\gamma_{NH_3}) = 1,96u(\gamma_{NH_3}) = 0,84 \text{ mg/m}^3$$

Table G.4 — Results of uncertainty calculation for a typical direct extractive NH₃ measurement by NDIR with GFC AMS based on results from field and laboratory tests

Performance characteristic	Partial standard uncertainty	Value of standard uncertainty at upper limit of the lowest measuring range used (mg/m ³)
Lack-of-fit	u_{lof}	0,18
Zero drift from field test	$u_{d,0}$	0,00
Span drift from field test	$u_{d,s}$	0,14
Influence of ambient temperature at span	$u_{inf,T}$	-0,33
Influence of sample pressure	$u_{inf,p}$	0,00
Influence of sample gas flow	$u_{inf,f}$	0,00
Influence of supply voltage	$u_{inf,V}$	0,00
Influence of interferents (cross sensitivity)	u_i	-0,13
Repeatability standard deviation at span	$u_{r,s}$	0,40
Uncertainty of the reference material	u_{adj}	0,23

Table G.4 (continued)

Performance characteristic	Partial standard uncertainty	Value of standard uncertainty at upper limit of the lowest measuring range used (mg/m ³)
Excursion of measurement beam	u_E	Not applicable
Converter efficiency for AMS measuring NO _x	$u_{conv.}$	Not applicable
Variation of response factors	$u_{var.}$	Not applicable

Test results have been taken from laboratory and field tests according to EN 15267.

Combined standard uncertainty and expanded uncertainty are calculated for the lowest measuring range of 10 mg/m³ NH₃ as follows.

Combined standard uncertainty:

$$u(\gamma_{\text{NH}_3}) = \sqrt{u_{r,0}^2 + u_{r,s}^2 + u_{lof}^2 + u_{d,0}^2 + u_{d,s}^2 + u_{inf,p}^2 + u_{inf,T}^2 + u_{inf,V}^2 + u_{i,CO_2}^2 + u_{adj}^2}$$

$$= 0,63 \text{ mg/m}^3$$

Expanded uncertainty:

$$U(\gamma_{\text{NH}_3}) = k \cdot u(\gamma_{\text{NH}_3}) = 1,96u(\gamma_{\text{NH}_3}) = 1,23 \text{ mg/m}^3$$

Bibliography

- [1] ISO 10396, *Stationary source emissions — Sampling for the automated determination of gas emission concentrations for permanently-installed monitoring systems*
- [2] ISO 12039, *Stationary source emissions — Determination of carbon monoxide, carbon dioxide and oxygen — Performance characteristics and calibration of automated measuring systems*
- [3] ISO 14385-1, *Stationary source emissions — Greenhouse gases — Part 1: Calibration of automated measuring systems*
- [4] ISO 14385-2, *Stationary source emissions — Greenhouse gases — Part 2: Ongoing quality control of automated measuring systems*
- [5] ISO/IEC Guide 98-3:2008, *Uncertainty of measurement — Part 3: Guide to the expression of uncertainty in measurement (GUM:1995)*

Bureau of Indian Standards

BIS is a statutory institution established under the *Bureau of Indian Standards Act, 2016* to promote harmonious development of the activities of standardization, marking and quality certification of goods and attending to connected matters in the country.

Copyright

BIS has the copyright of all its publications. No part of these publications may be reproduced in any form without the prior permission in writing of BIS. This does not preclude the free use, in the course of implementing the standard, of necessary details, such as symbols and sizes, type or grade designations. Enquiries relating to copyright be addressed to the Head (Publication & Sales), BIS.

Review of Indian Standards

Amendments are issued to standards as the need arises on the basis of comments. Standards are also reviewed periodically; a standard along with amendments is reaffirmed when such review indicates that no changes are needed; if the review indicates that changes are needed, it is taken up for revision. Users of Indian Standards should ascertain that they are in possession of the latest amendments or edition by referring to the website- www.bis.gov.in or www.standardsbis.in.

This Indian Standard has been developed from Doc No.: CHD 35(17394).

Amendments Issued Since Publication

Amend No.	Date of Issue	Text Affected

BUREAU OF INDIAN STANDARDS

Headquarters:

Manak Bhavan, 9 Bahadur Shah Zafar Marg, New Delhi 110002
Telephones: 2323 0131, 2323 3375, 2323 9402

Website: www.bis.gov.in

Regional Offices:

	Telephones
Central : 601/A, Konnectus Tower -1, 6 th Floor, DMRC Building, Bhavbhuti Marg, New Delhi 110002	{ 2323 7617
Eastern : 8 th Floor, Plot No 7/7 & 7/8, CP Block, Sector V, Salt Lake, Kolkata, West Bengal 700091	{ 2367 0012 2320 9474
Northern : Plot No. 4-A, Sector 27-B, Madhya Marg, Chandigarh 160019	{ 265 9930
Southern : C.I.T. Campus, IV Cross Road, Taramani, Chennai 600113	{ 2254 1442 2254 1216
Western : Plot No. E-9, Road No.-8, MIDC, Andheri (East), Mumbai 400093	{ 2821 8093

Branches : AHMEDABAD. BENGALURU. BHOPAL. BHUBANESHWAR. CHANDIGARH. CHENNAI. COIMBATORE. DEHRADUN. DELHI. FARIDABAD. GHAZIABAD. GUWAHATI. HIMACHAL PRADESH. HUBLI. HYDERABAD. JAIPUR. JAMMU & KASHMIR. JAMSHEDPUR. KOCHI. KOLKATA. LUCKNOW. MADURAI. MUMBAI. NAGPUR. NOIDA. PANIPAT. PATNA. PUNE. RAIPUR. RAJKOT. SURAT. VISAKHAPATNAM.