

---

---

ग्राफ़िक प्रौद्योगिकी — पोस्ट-प्रेस — बाध्य  
उत्पादों के लिए अपेक्षाएँ

Graphic Technology —  
Post-Press — Requirements for  
Bound Products

ICS 37.100.01

© BIS 2024  
© ISO 2016



भारतीय मानक ब्यूरो  
BUREAU OF INDIAN STANDARDS  
मानक भवन, 9 बहादुर शाह ज़फर मार्ग, नई दिल्ली - 110002  
MANAK BHAVAN, 9 BAHADUR SHAH ZAFAR MARG  
NEW DELHI - 110002  
[www.bis.gov.in](http://www.bis.gov.in) [www.standardsbis.in](http://www.standardsbis.in)

## NATIONAL FOREWORD

This Indian Standard which is identical to ISO 16763 : 2016 'Graphic technology — Post-press — Requirements for bound products' issued by the International Organization for Standardization (ISO) was adopted by the Bureau of Indian Standards on the recommendation of the Graphic Art Technology Sectional Committee and approval of the Management and Systems Division Council.

The text of the International Standard has been approved as suitable for publication as an Indian Standard without deviations. Certain conventions are, however, not identical to those used in Indian Standards. Attention is particularly drawn to the following:

- a) Wherever the words 'International Standard' appear referring to this standard, they should be read as 'Indian Standard'; and
- b) Comma (,) has been used as a decimal marker while in Indian Standards, the current practice is to use a point (.) as the decimal marker.

In this adopted standard, references appear to certain International Standards for which Indian Standards exist. The corresponding Indian Standards, which is to be substituted in its place, is listed below along with its degree of equivalence for the edition indicated:

<i>International Standard</i>	<i>Corresponding Indian Standard</i>	<i>Degree of Equivalence</i>
ISO 534 Paper and board — Determination of thickness, density and specific volume	IS 1060 (Part 5/Sec 3) : 2014/ ISO 534 : 2011 Methods of sampling and test for paper and allied products: Part 5 Methods of test for paper and board, Section 3 Determination of thickness, density and specific volume	Identical
ISO 536 Paper and board — Determination of Grammage	IS 1060 (Part 5/Sec 5) : 2021/ ISO 536 : 2019 Methods of sampling and test for paper and allied products: Part 5 Methods of test for paper and board, Section 5 Determination of grammage ( <i>first revision</i> )	Identical

Annex A is integral part of this standard.

For the purpose of deciding whether a particular requirement of this standard is complied with, the final value, observed or calculated, expressing the result of a test or analysis, shall be rounded off in accordance with IS 2 : 2022 'Rules for rounding off numerical values (*second revision*)'. The number of significant places retained in the rounded off value should be the same as that of the specified value in this standard.

# Contents

Page

<b>Introduction</b> .....	<b>iv</b>
<b>1 Scope</b> .....	<b>1</b>
<b>2 Normative references</b> .....	<b>1</b>
<b>3 Terms and definitions</b> .....	<b>1</b>
3.1 Conversion processes.....	1
3.2 Binding methods.....	2
3.3 Product and structure.....	3
3.4 Component and binding material.....	4
3.5 Binding quality evaluation.....	5
<b>4 Process requirements</b> .....	<b>5</b>
4.1 General.....	5
4.2 Cutting for folding.....	6
4.2.1 Preparation.....	6
4.2.2 Cutting accuracy.....	6
4.3 Folding.....	7
4.3.1 Fold types.....	7
4.3.2 Folding control.....	8
4.3.3 Folding quality.....	8
4.4 Assembling into blocks.....	8
4.4.1 Gathering.....	8
4.4.2 Pasting on endpapers.....	8
4.4.3 Inserting.....	9
4.5 Binding.....	9
4.5.1 Adhesive binding.....	9
4.5.2 Thread sewing.....	10
4.5.3 Thread sealing.....	11
4.5.4 Lock-stitching.....	11
4.5.5 Saddle-stitching.....	11
4.5.6 Single-sheet binding (spiral, wire-o, comb).....	12
4.6 Trimming.....	13
4.7 Case-bound book production.....	14
4.7.1 General.....	14
4.7.2 Rounding and backing.....	14
4.7.3 Inserting a bookmark.....	14
4.7.4 Back-lining.....	14
4.7.5 Attaching headbands.....	14
4.7.6 Case construction.....	14
4.7.7 Casing-in.....	16
4.7.8 Joint forming.....	17
4.7.9 Adding a jacket.....	17
4.8 Paper-bound book production.....	17
4.8.1 Size of the cover.....	17
4.8.2 Weight of the cover.....	18
4.8.3 Cover application.....	18
<b>5 Binding quality control</b> .....	<b>18</b>
5.1 General.....	18
5.2 Sampling.....	18
5.3 Inspection of the final products.....	18
<b>Annex A (normative) Method to measure degree of warping of finished products</b> .....	<b>20</b>
<b>Bibliography</b> .....	<b>21</b>

## Introduction

Bound products, such as booklets, brochures, case-bound or paper-bound books, etc., are commonly used in daily life across countries. Post-press is the last but not the least process in the production flow of bound products, which includes pre-press, printing and post-press. This International Standard introduces the use of the standardization approach to accomplish the conversion of printed sheets into end products and to achieve the desired result.

Post-press production has a significant effect on the appearance, usability and durability of bound products. The aim of this International Standard is to address the major quality elements in post-press production of such products.

Post-press production of bound products involves four major processes: cutting, folding, assembling and binding. As the process steps are interrelated and sequential, any deviations from current practice can lead to deficiencies in the end product. Accordingly, this International Standard specifies technical requirements and tolerances for the outcomes of processing operations in order to avoid quality deficiencies. Although material specification is not covered in this International Standard because this is not normally the responsibility of the finisher, it is recommended that, if a long life is required for the bound product, ISO 9706 gives guidance.

This International Standard is expected to benefit both manufacturers and customers in the printing and publishing industries in terms of the production and assessment of bound products.

The use of this International Standard is intended to

- enhance overall process control of the production of bound products,
- enhance production efficiency and accuracy in post-press processes,
- reduce occurrence of remakes resulting from inadequate working methods, and
- promote transparency of the quality requirements of post-press operations in a universally understood manner.

This International Standard does not cover special effect or surface decorations.

*Indian Standard***GRAPHIC TECHNOLOGY — POST-PRESS — REQUIREMENTS  
FOR BOUND PRODUCTS****1 Scope**

This International Standard specifies quality requirements and tolerances of bound products and intermediate components. It is applicable to products requiring industrial binding, for example, books, magazines, catalogues and brochures.

**2 Normative references**

The following documents, in whole or in part, are normatively referenced in this document and are indispensable for its application. For dated references, only the edition cited applies. For undated references, the latest edition of the referenced document (including any amendments) applies.

ISO 534, *Paper and board — Determination of thickness, density and specific volume*

ISO 536, *Paper and board — Determination of grammage*

**3 Terms and definitions**

For the purposes of this document, the following terms and definitions apply.

**3.1 Conversion processes****3.1.1****backing**

shaping a ridge or shoulder on each side of the spine of a book block after rounding, ideally complemented by gluing a material stripe on the spine with the same width as the spine

**3.1.2****binding**

holding signatures or sheets together along one edge by means of staples, adhesives, thread, wire or other means

Note 1 to entry: Most of the time, the binding process also includes attaching a cover to the bound block.

**3.1.3****casing in**

gluing endpapers to the inside of the case to anchor the bound and trimmed book block into the case

**3.1.4****cutting**

using a mechanical device (e.g. blade) to reduce sheets to a size that is suitable for further processing

**3.1.5****creasing**

indenting lines into substrates, such as cardboard or paper, to guide subsequent folding operations and to prevent cracking

**3.1.6  
folding**

bending a printed or blank substrate upon itself in order to achieve specified dimensions and folding layouts

Note 1 to entry: It is important that the correct imposition is used at the printing stage in order to obtain the sequence of pages in a bound product, as well as to compensate the creep.

**3.1.7  
gathering**

assembling either by collating of signatures to form a multi-layer block or by inserting one signature inside another signature to form a single-layer block

**3.1.8  
gluing-off**

applying glue on the spine of a thread sewn or thread sealed book block

**3.1.9  
inserting**

assembling signatures one inside another or putting loose inserts into print products

**3.1.10  
back-lining**

covering the glued spine by a material stripe with an extension on front and back side of the book block

**3.1.11  
rounding**

forming, by mechanical or manual manipulation, the spine of a book block into a convex shape prior to backing

**3.1.12  
trimming**

cutting off the edges of a blank or printed substrate or book block to achieve the required format

**3.2 Binding methods**

**3.2.1  
adhesive binding**

converting process used to join, by gluing individual pages or signatures and covers into a final product

Note 1 to entry: There are different types of adhesive binding that result from the different processes of spine preparation prior to the application of adhesive; commonly used types are notch binding and perfect binding.

**3.2.2  
lock-stitching**

sewing method where two threads, an upper and a lower, are used to link together in stitching

Note 1 to entry: This method is used mainly for identity cards and passports.

**3.2.3  
notch binding**

type of adhesive binding where slots are cut into the spine edges of the gathered signatures to facilitate the penetration of adhesive

**3.2.4  
perfect binding**

type of adhesive binding in which gathered signatures or sheets are connected to a book block by applying glue on the binding edge after executing spine preparation techniques

Note 1 to entry: In the broad sense, perfect binding is also used as an alternate term for adhesive binding.

**3.2.5****saddle-stitching**

binding method where a set of folded and inserted signatures is bound with stitches or staples driven down through the centre fold of the spine

Note 1 to entry: This method is used mainly for menus, brochures and magazines.

**3.2.6****single-sheet binding**

type of non-adhesive binding in which the single sheets are held together by a plastic or metal binding tool (spiral, wire-o and comb), showing a particular good lay-flat behaviour.

Note 1 to entry: This method is used mainly for products that need to lay flat when opened, such as board books, cookbooks, notebooks, calendars and manuals.

**3.2.7****thread sealing**

sealing method used as an economical alternative to thread sewing, where the signatures are bound with single thread staples containing a thermoplastic coating during the folding process

**3.2.8****thread sewing**

binding method where the gathered signatures are sewn together with thread before being inserted into a cover or book case

Note 1 to entry: There are two thread sewing methods: sewing with stitches on a straight line and sewing with stitches on a staggered line.

**3.3 Product and structure****3.3.1****binding edge**

edge of a book block along which signatures or pages are bound by means of staples, adhesives, thread, wire or other means

**3.3.2****binding margin**

white space that is left blank between the binding edge and the printed area of a page

**3.3.3****case-bound book**

set of blank, written or printed pages bound in a case made of solid boards glued onto the end paper of a book block

**3.3.4****bound product**

book or book block, made up of one or more folded sheets or single sheets, held together by a particular binding method, with or without a cover

**3.3.5****brochure**

set of blank, written or printed pages bound together in a cover made of cardboard (soft-cover)

**3.3.6****fore edge**

front edge of a book or book block that is opposite, and parallel, to its binding edge

**3.3.7****head**

top edge of a book or a book block

**3.3.8**

**joint**

one of two grooves that run head to tail on the outside of the case, front and back, in the gap between spine inlay and case boards

**3.3.9**

**Omega staples**

variant of wire staples with shaped eyelets to be used as file holes

Note 1 to entry: Loop stitch is same as Omega staple.

**3.3.10**

**shoulder**

outer edge on each side of the rounded spine of a book block that is formed by the backing process

**3.3.11**

**spine**

back of a book block or outer portion of a book where the pages are held together, opposite to the fore edge

**3.3.12**

**squares**

edges of the book case extending beyond the book block at the head, tail and fore edges

**3.3.13**

**tail**

bottom edge of a book or a book block

**3.4 Component and binding material**

**3.4.1**

**book block**

part of a case-bound book or brochure, consisting of a trimmed or untrimmed bound block of sheets, prior to the application of the book case or cover

**3.4.2**

**bookmark**

fabric ribbon, one end of which is normally glued onto the top of the spine, inserted between the pages of a book to mark the reader's place

**3.4.3**

**case**

hardcover of a book composed of front and rear boards, spine inlay and covering material

**3.4.4**

**cover**

flexible or rigid cardboard connected to the book block to protect and strengthen it

**3.4.5**

**covering material**

flexible material, which can be paper or fabric, attached to the case boards and the spine inlay of a case

**3.4.6**

**end paper**

folded sheet used at the front and back of a book block to connect it with the case using glue

**3.4.7**

**headband**

decorative fabric band glued onto the upper and lower edges of the spine of a book block



**3.4.8****multi-layer block**

book block assembled by collation of signatures in page order

**3.4.9****overhang**

part of the covering material that extends beyond the edges of the case boards and spine inlay before turning-in

**3.4.10****signature**

printed sheet, single or multiple folded to be used as part of a book block

**3.4.11****single-layer block**

book block consisting of a single signature or assembled by inserting signatures into one another, which can be bound to form a thin magazine, a booklet or document with a limited number of pages

**3.4.12****spine inlay**

stripe of cardboard or solid board attached with gaps between the front and rear boards of a case

**3.4.13****turn-in**

overhang that is turned over the edges of the case boards and spine inlay onto their inside surface of the case

**3.5 Binding quality evaluation****3.5.1****glue penetration**

uncontrolled and inhomogeneous penetration of glue between the sheets of a book block

**3.5.2****grain direction**

direction in which the majority of the fibres in a piece of paper, cardboard or solid board are aligned and the direction in which the warp threads run in cloth

Note 1 to entry: The grain direction in a sheet of machine-made paper is also referred to as the machine direction.

Note 2 to entry: The sheet is called long grain if the larger dimension is parallel to the machine direction (MD). The sheet is called short grain if the larger dimension is parallel to the cross direction (CD).

Note 3 to entry: In book binding, the right grain direction is preferentially parallel to the binding edge.

**4 Process requirements****4.1 General**

Post-press production of bound products is carried out in a series of process operations. A typical workflow is shown in [Figure 1](#) and, for each operation, the number of the clause describing it is given in parentheses.

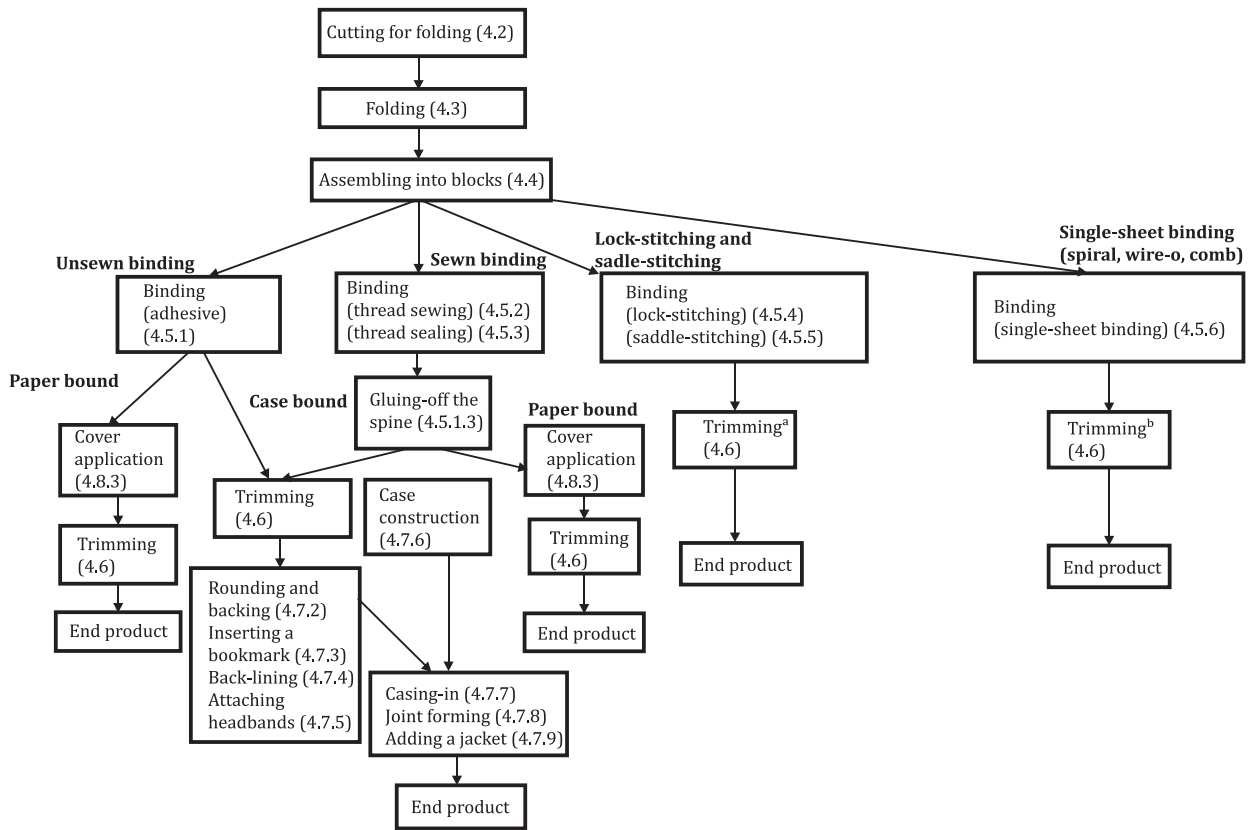

**Key**

- a For some lock-stitched blocks, cover application (if necessary) takes place before trimming.
- b For single-sheet binding, trimming (if necessary) takes place before binding.

NOTE The number in parentheses in each box refers to the number of the relevant clause in this International Standard.

**Figure 1 — Workflow chart for bound products**

All processes shall be performed in a way that no markings, ink transfer, wrinkles, cracks, etc. occur. There shall be prior information exchange between parties on all aspects of quality of the end or final product. This includes information on the standardized climatic condition of the region of use.

**4.2 Cutting for folding**

**4.2.1 Preparation**

Prior to the cutting operation, tests for cutting pressure shall be performed to ensure the avoidance of marking in subsequent processes.

**4.2.2 Cutting accuracy**

**4.2.2.1 Piles of sheets**

A first master edge (usually identifiable by the printed register mark) shall be defined, either parallel or perpendicular to the printed content, and a second master edge shall be defined; the angle between them shall be  $90^\circ \pm 0,2^\circ$ . If the angle between the master edges cannot be guaranteed, the following edge and squareness tolerances shall apply.

The squareness and dimensions of a cut pile shall be determined by taking the measurement of two sample sheets (one from the top and one from the bottom of the pile). The squareness of the sheet shall be determined by measuring both the horizontal and vertical edges (W1, W2, H1, H2) and the diagonal lines (X, Y) as shown in [Figure 2](#), where the squareness tolerance is given by the values of  $W1 - W2$ ,  $H1 - H2$  and  $X - Y$ , each value shall be  $\pm 0,5$  mm. For dimensional accuracy tolerance, the value shall be 1,0 mm per 1 000 mm.

A calibrated measuring device shall be used to take measurements.

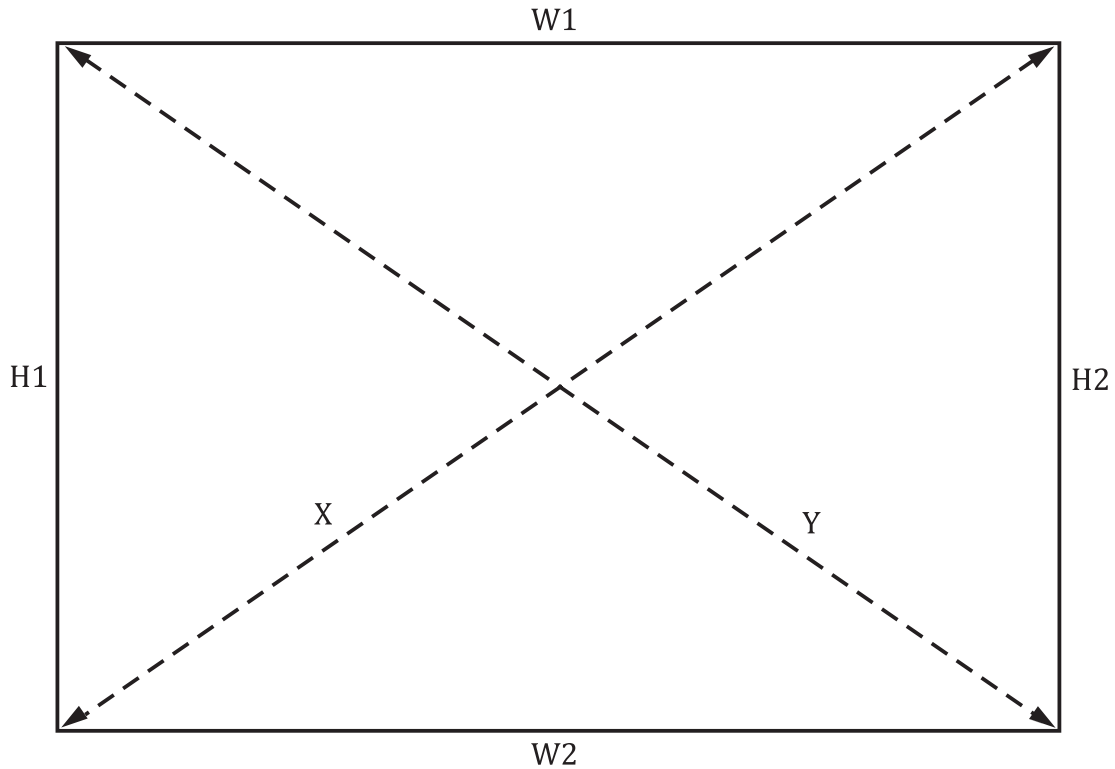

**Figure 2 — Measurement of edges and diagonal lines for squareness**

#### 4.2.2.2 Web-fed cutting

In cutting for web-fed production, the position of the cutting edge and any perforation shall be within 1,0 mm of the design cutting position.

#### 4.2.2.3 Cutting quality

After any cutting operation and removal of the waste from the cut edges, the material shall match the desired shape and dimensions and be free from pressure marks, knife marks, ink transfer, breaks and burring due to a blunt cutting instrument.

### 4.3 Folding

#### 4.3.1 Fold types

The appropriate fold type and imposition schema for a signature is provided as part of the job information.

### 4.3.2 Folding control

Folded products should show no cracking along the fold or any wrinkles.

NOTE To prevent cracking, pre-creasing along fold lines can be carried out and, to prevent wrinkles, perforation can be carried out.

### 4.3.3 Folding quality

Measurement for folding accuracy shall be taken on the last folding position using reopened unbound signatures under a graduated magnifier. The deviation tolerances between the last folding position and the folding marks for different numbers of folds shown in [Table 1](#) shall apply. For papers of higher grammage, fewer folds should be made. The grammage of paper shall be determined as described in ISO 536.

**Table 1 — Deviation tolerance for folding accuracy**

Number of folds	Deviation tolerance	Applicability of the tolerance
	mm	
1 fold	0,60	Substrates up to 200 g/m <sup>2</sup>
2 folds	0,70	Substrates up to 180 g/m <sup>2</sup>
3 folds	0,90	Substrates up to 150 g/m <sup>2</sup>
4 folds	1,00	Substrates up to 100 g/m <sup>2</sup>

NOTE If papers have a high bulk, the folding accuracy will be affected. The basis weight is intended as a guide. If papers with higher basis weights are to be folded more often than indicated in [Table 1](#), larger folding deviations may result.

## 4.4 Assembling into blocks

### 4.4.1 Gathering

During gathering, signatures shall be aligned both to the leading edge and to the spine with a deviation tolerance of  $\pm 0,5$  mm. The correctness of the sequence of signatures shall be checked (either visually by collating marks or automatically by an inspection system).

NOTE Gathering can be performed in more than one process to form multi-layer blocks or single-layer blocks.

If an overlap is required for a gathering operation, the trim-cut overlap should be appropriate to the device used.

NOTE The trim-cut overlap is usually a minimum of 5 mm.

### 4.4.2 Pasting on endpapers

The fold of each endpaper on the first and last signatures respectively should have an offset of  $(1,5 \pm 0,5)$  mm from the outermost fold of the signature. The adhesive line shall be straight and have a maximum width of 5,0 mm, clear of ink or varnish. The endpaper shall be aligned with the signature on the head. See [Figure 3](#).

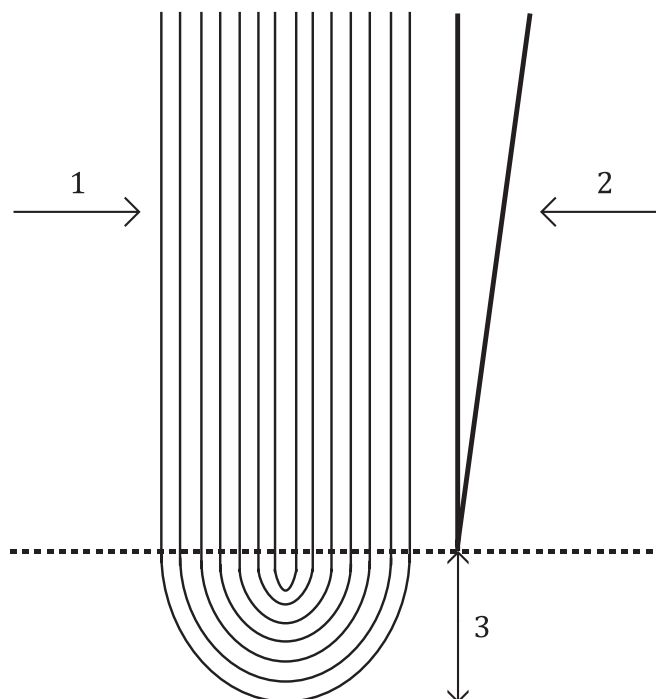
**Key**

- 1 folded signature
- 2 endpaper
- 3 offset

**Figure 3 — Position of the endpaper**

#### 4.4.3 Inserting

When other folded sheets or loose inserts need to be inserted into a block, the following criteria shall be observed.

- a) The size of any insert shall not be larger than the size of the normal signatures in the end product.
- b) Different inserts, for example a single insert, an odd-sized insert or fold-outs, may be glued or sewn into the block by machine or manually.
- c) The size of any fold-outs shall be at least 2,0 mm smaller than the final product size, so as to avoid any over-cut in trimming. The four sides of the fold-outs should be parallel to those of the block.
- d) Odd-sized inserts shall be placed between full-sized signatures.

#### 4.5 Binding

##### 4.5.1 Adhesive binding

###### 4.5.1.1 Notch binding

Notches cut into the folds of the gathered signatures shall have the depth and spacing compatible with the paper type and the composition of the adhesive. Usually, each notch should go through the folds and may be from 15 mm to 18 mm in length, with a spacing of 3,0 mm to 5,0 mm.

#### 4.5.1.2 Perfect binding

In perfect binding, the folds of the gathered signatures shall be milled off. If single sheets are being bound, then they can be built up to form the block without the need to grind anything off. Depending on the paper thickness and the number of pages per signature, the depth of milling shall ensure the separation of the block into individual sheets. Notching and roughening may be applied to improve the adhesion. During all these processes the alignment of the signatures shall be kept. The milling shall be even across the spine. There should be no printing, varnishing or previously applied glue in the area reserved for gluing, which should also be free of dust.

#### 4.5.1.3 Application of spine and side glue

The coating layer of the adhesive should be bubble-free and uniform with a thickness in accordance with the technical specification of the glue manufacturer.

The operating temperature of the adhesive and any other operational requirements shall be in accordance with the technical specification of the glue manufacturer.

Glue penetration of more than 1,0 mm on a significant number of pages should be avoided.

The thickness of the side glue should be kept as low as possible. Excess glue shall not be visible anywhere in the final product.

#### 4.5.2 Thread sewing

Thread sewing should be used for products of high durability, frequent usage and also for papers with a high basis weight.

The thread used shall be stronger than the substrate. The stitches shall be evenly distributed on the spine fold. The stitching holes shall align with the centre fold with a deviation tolerance of  $\pm 0,5$  mm. The tension in the thread should be such that the signatures are bound tightly together without there being any wrinkles or tearing. Any torn thread or missing stitches shall be avoided.

Any signature of the thread sewn book block shall be aligned to the head with a tolerance of  $\pm 0,5$  mm.

For a good bonding of the signatures of a book block, the number of stitching groups should correspond to the spine length, the stitching arrangement in [Table 2](#) is recommended.

Staggered stitching should be used to avoid spine build-up, if necessary.

The thread sewing process shall be followed by the process of gluing-off the spine. The requirements of [4.5.1.3](#) apply.

**Table 2 — The stitching arrangement for different spine lengths of a book block**

Spine length of book block mm	Maximum distance from the head and to the tail left without stitches mm	Minimum number of stitching groups
>420	25	8
297 - 420	25	6
210 - 296	20	4
148 - 209	15	3
105 - 147	15	2

When the spine length of a book block is equal to or less than 105 mm and the block thickness is no more than 6 mm, lock-stitching is recommended.

### 4.5.3 Thread sealing

Thread sealing is carried out following the folding process, where thread staples with a thermoplastic coating shall be pushed from the inside to the outside of the sheet prior to the last fold and then the thread ends shall be laid out backwards and fused to the spine of the sheet by pressure and heat. The staples shall align with the binding edge with a tolerance of  $\pm 0,5$  mm. The staple length should be more than 12 mm, the spacing between the staples should be less than 38 mm.

The thread sealing process shall be followed by the process of gluing-off the spine with a lining stripe. The requirements of [4.5.1.3](#) apply.

NOTE Thread sealing is considered as an alternative to thread sewing or perfect binding.

### 4.5.4 Lock-stitching

Lock-stitching (saddle or side) should be used for combining a low number of signatures or sheets with a maximum spine thickness of 6,0 mm. Although thread is used in these methods, the methods are not described as thread sewing. There should be three to four stitches per 10 mm. For side lock-stitching, there should be a space of  $4,0 \text{ mm} \pm 1,0 \text{ mm}$  between the centre fold and the stitching line.

### 4.5.5 Saddle-stitching

Saddle-stitching may be applied to the binding of single-layer blocks. The maximum block thickness is related to the staple format. Blocks stitched with flat staples should have a maximum thickness of 8,0 mm. Blocks stitched with Omega staples should have a maximum thickness of 6,0 mm with a loop diameter of 6,0 mm.

The gauge of the wire used for the staples should be dependent upon the block thickness (see [Table 3](#)). The distance between each staple (outer staples if there are more than two) and the nearest edge a or c should be equal with a tolerance of 3,0 mm (see [Figure 4](#)). The distance between the two staples b should be greater than one third of the height of the product. For the Omega format, the position tolerance should be  $\pm 2,0$  mm and the Omega staple formation tolerance should be  $\pm 1,0$  mm.

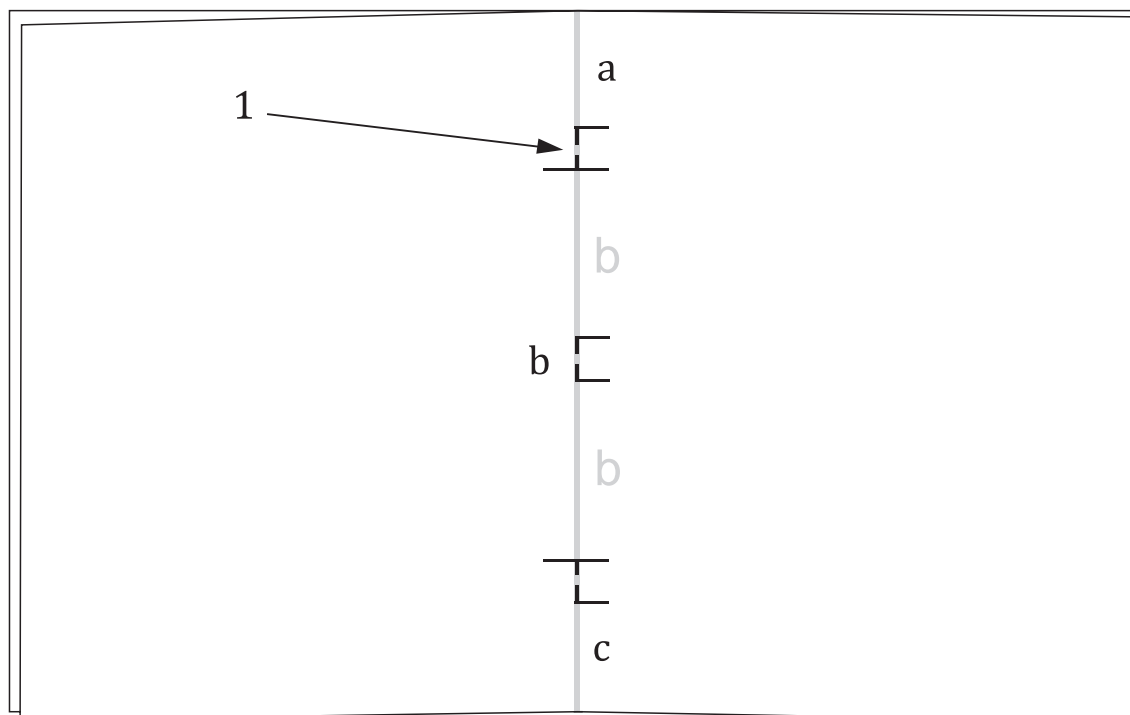

**Key**  
 1 staple

**Figure 4 — Positioning of staples in saddle-stitched products (showing optional third staple)**

Each staple should have its two legs bent over with a maximum space of 3,0 mm between the ends of the wire. The staples shall align with the centre fold with a tolerance of  $\pm 0,5$  mm. A creasing of the cover is recommended when using thicker cover stock and lamination is recommended to prevent tearing of the cover around the staples.

**Table 3 — Minimum wire gauge for staples**

Book block thickness mm	Wire gauge BWG	Wire diameter mm
<5	26	0,46
5 - 10	25	0,51
>10	22	0,71

NOTE BWG = Birmingham Wire Gauge, a British wire measurement system that is widely used throughout the world.

**4.5.6 Single-sheet binding (spiral, wire-o, comb)**

Single-sheet binding includes spiral, wire-o and comb binding. During the binding process, the book block shall be punched or drilled with a series of small holes (square or round) along the binding edge and a metal or plastic coil shall be threaded through the holes in spiral binding; a set of double wire loops shall be inserted into the holes in wire-o binding or a plastic comb shall be inserted into the holes in comb binding, so as to hold the cover and the pages together. The holes in the cover shall be in alignment with that in the pages.

For a reliable binding result, the specifications of the plastic or wire used should correspond to the thickness of the gathered pages and a side clearance should be maintained to ensure easy opening and to avoid tearing of the paper. Recommended parameters are given in [Table 4](#) and [Table 5](#). The loops of



the binding shall be fully closed and not distorted through excess pressure in the closing process. The ends of the plastic or wire shall not protrude from the product.

**Table 4 — Specification for wire-o binding**

Wire gauge mm	Product thickness mm	Loop diameter mm	Pitch mm	Side clearance mm
4,8	3,0	4 × 4	8,47	2,0
6,4	4,0	4 × 4	8,47	2,5
7,9	6,0	4 × 4	8,47	3,0
9,5	7,5	4 × 4	8,47	3,0
11,1	8,5	5 × 4	8,47	3,0
12,7	10,0	5 × 4	8,47	3,0
14,3	12,0	5 × 4	8,47	3,0
15,9	13,5	5 × 5	12,7	3,5
19,0	14,5	5 × 5	12,7	3,5
22,2	17,5	6 × 6	12,7	4,0
25,4	22,0	6 × 6	12,7	4,0
31,8	27,0	6 × 6	12,7	5,0

**Table 5 — Specification for spiral binding**

Coil gauge mm	Product thickness mm	Coil diameter mm	Pitch mm	Side clearance mm
4,8	3,0	4,7	8,47	2,0
6,4	4,0	6,3	8,47	2,5
7,9	6,0	7,9	8,47	3,0
9,5	7,5	9,5	8,47	3,0
11,1	8,5	11,0	8,47	3,0
12,7	10,0	12,7	8,47	3,0
14,3	12,0	14,3	8,47	3,0
15,9	13,5	16,0	12,7	3,5
19,0	14,5	19,0	12,7	3,5
22,2	17,5	22,2	12,7	4,0
25,4	22,0	25,4	12,7	4,0
31,8	27,0	30,0	12,7	5,0

For comb binding, follow the recommendations of the system provider.

#### 4.6 Trimming

Trimming with a guillotine or a three-knife trimmer shall avoid marks from the pressing bar and the cutting table. Trimming shall be performed after sufficient drying of the glue. After trimming, the book or book block shall have its spine free of wrinkles, and 90° angles in each of the four corners of both the front and back. The trim size and squareness tolerances shall be ±0,5 mm for thicknesses up to 30 mm and ±1,0 mm for thicknesses greater than 30 mm. For measurement, see [Figure 2](#) in [4.2.2.1](#). The dimensions from front to back should be equal with a tolerance of ±0,5 mm for thicknesses up to 30 mm and ±1,0 mm for thicknesses greater than 30 mm. Brochures with protruding flaps shall be trimmed without damaging the flaps.

## 4.7 Case-bound book production

### 4.7.1 General

Sequence of individual processes may vary according to different manufacturing recommendation.

### 4.7.2 Rounding and backing

Where applicable, book blocks shall be evenly rounded from head to tail and backed to form shoulders on both sides. The height of the shoulders shall be equal to or slightly less than the thickness of the case board. Rounding and backing should be performed on book blocks with a thickness of over 13 mm, or if no rigid spine inlay is used.

NOTE Some product types, such as photo books, are typically produced without rounding and backing.

### 4.7.3 Inserting a bookmark

If a bookmark is used, the ribbon shall be inserted into the block and glued close to the middle of the spine approximately 20 mm from the head. The length of the ribbon shall be at least 10 mm longer than the diagonal line of the book block. If there is more than one bookmark, they should be positioned evenly throughout the book block.

### 4.7.4 Back-lining

Fabrics, paper or compounds should be used as back-lining material to reinforce the spine of the block. The back-lining material shall be evenly and firmly attached to the spine. The first lining should extend beyond the book block, while further linings should have the same width as the book block. The height of the lining can be either the same as the book block (application before trimming) or smaller (application after trimming). The lining material should be appropriate for the size and weight of the book block and the intended stiffness of the spine.

### 4.7.5 Attaching headbands

When headbands are applied, the width shall be equal to the width of the spine with a tolerance of  $\pm 0,5$  mm. They shall be attached squarely and firmly to the spine and be clearly visible.

### 4.7.6 Case construction

#### 4.7.6.1 Case boards

Front and rear boards (see [Figure 5](#)) shall be cut squarely and smoothly, with the grain direction running parallel to the spine. The height of the boards shall be the height of the book block plus the squares on the head and the tail. The width of the boards shall be the width of the book block plus the square on the fore edge minus the space between the spine inlay and case boards that is left for creating a joint.

The board thickness may be between 1,5 mm and 3,5 mm or even larger, which should be appropriate for the size and weight of the book block. The thickness shall be measured according to ISO 534. Squares on boards should correspond to the size of the book block and the thickness of the board. The correlated variables listed in [Table 6](#) should be applied.

**Table 6 — Book block size, board thickness and squares width**

Book block size	Under A5 (B6) mm	A5 (B6) to A4 (B5) mm	Above A4 (B5) mm
Board thickness	≥1,5	≥2,0	≥3,5
Square width	3,0 ± 0,5	3,5 ± 0,5	4,0 ± 0,5

#### 4.7.6.2 Spine inlay

The spine inlay (see [Figure 5](#)) shall be cut squarely with the grain direction running parallel to the spine. Its width may be roughly calculated by the spine width plus two thicknesses of the board, but shall be verified using a book block showing all essential properties of the book block to be used later. Its length shall be equal to the height of the case board with a tolerance of -0,5 mm (it shall not be longer than the board). Selection of the material for the spine inlay shall be made in accordance with the shape of the spine (rounded or square). For a square spine, the spine inlay should be the same as the case board, while, for a rounded spine, a suitable cardboard with a lower basis weight can be considered.

#### 4.7.6.3 Covering materials

The height of the covering material shall be equal to the height of the case boards plus the thickness of the boards plus a head and tail overhang. The width of the covering material shall be equal to the width of two boards plus two thicknesses of the board plus two fore edge overhangs plus the width of the spine inlay and the spaces between the inlay and the two boards (see [Figure 5](#)).

#### 4.7.6.4 Casemaking

Front and rear boards and the spine inlay shall be firmly fixed to the covering material with glue. The spaces between the spine inlay and the boards shall be uniform and approximately 6,0 mm to 13 mm wide, depending on the thickness of the boards and the intended product properties. The covering material shall be turned in tightly and uniformly, approximately 15 mm to 20 mm wide on all sides, and shall adhere neatly and tightly to the edges of the boards. The corners of the covering material shall be cut at a 45° angle and the distance between board corner and cut edge shall be high enough to completely cover the boards (see [Figure 5](#)), so that after turning-in no grey board is visible.

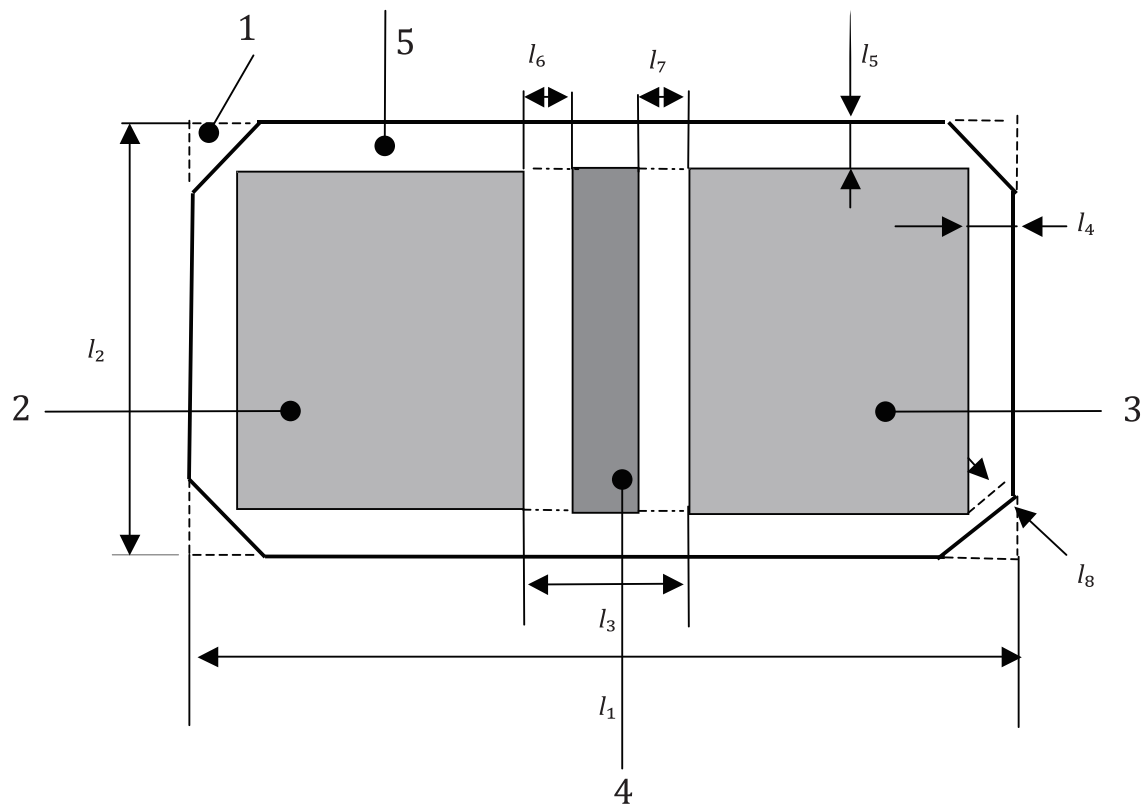

**Key**

- |   |                   |       |   |
|---|-------------------|-------|---|
| 1 | cut edge          | $l_1$ | width of covering material                |
| 2 | front board       | $l_2$ | height of covering material               |
| 3 | rear board        | $l_3$ | space between two boards                  |
| 4 | spine inlay       | $l_4$ | width of turn-in on fore edge             |
| 5 | covering material | $l_5$ | width of turn-in on head and tail         |
|   |                   | $l_6$ | space between spine inlay and front board |
|   |                   | $l_7$ | space between spine inlay and rear board  |
|   |                   | $l_8$ | distance between board cover and cut edge |

**Figure 5 — Case construction**

**4.7.7 Casing-in**

The book block shall be positioned with its spine correctly aligned to the spine inlay of the case. Endpapers shall be pasted down fully and smoothly onto the case boards and be free of wrinkles and bubbles. All squares should be uniform around the perimeter of the book block with a tolerance of  $\pm 1,0$  mm. The joint shall be formed squarely and securely. See [Figure 6](#).

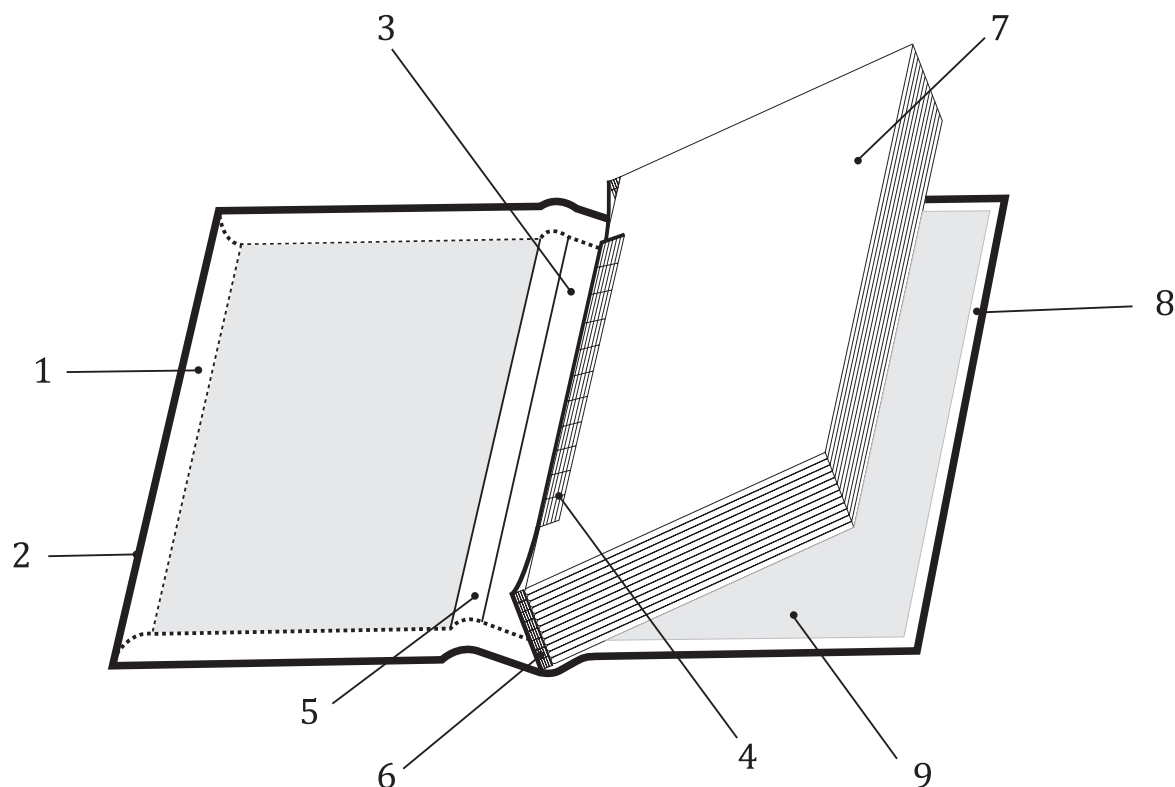
**Key**

1	covering material	6	headband
2	case board	7	block
3	spine inlay	8	square
4	back-lining material	9	endpaper
5	joint		

**Figure 6 — Casing-in****4.7.8 Joint forming**

The joint of the case should be formed by pressure and heat to achieve a bonding between the joint and the extension of the back-lining material.

**4.7.9 Adding a jacket**

Where a paper dust jacket is added to a casebound book as a detachable outer cover, its height shall be equal to the height of the case with a tolerance of  $-1,0$  mm. The width of the dust jacket shall be equal to the width of the case plus at least 40 mm for each flap. The jacket shall be wrapped around the book with flaps folded along the fore edge. If a cover band is used, it should be as wide as the paper dust jacket and its height should be at least 50 mm.

**4.8 Paper-bound book production****4.8.1 Size of the cover**

The cover material shall extend beyond the applied spine glue and be larger in width and height than the block so that after trimming edges are all flush. If the cover includes flaps, the width of the cover

material shall include the width of the flaps. For many cover applications, a minimum flap width of 30 mm is recommended.

NOTE See also [4.6](#).

#### 4.8.2 Weight of the cover

The weight of the cover material should be proportional to the size, thickness and weight of the book block; the thicker the book block, the heavier the cover material. The recommended relationship between thickness of the book block and the cover basis weight is given in [Table 7](#).

**Table 7 — Thickness of the book block and the basis weight of the cover paper**

Book block thickness	Cover basis weight g/m <sup>2</sup>
Up to 15 mm	120 – 250
From 15 mm to 30 mm	150 – 320
Above 30 mm	200 – 400

#### 4.8.3 Cover application

To allow a precise wrapping of the cover around the book block, the cover should be prepared by creasing at the position of the spine edges. Additionally, two more creases might be executed to create a hinge on front and rear cover, positioned with a distance of 6,0 mm to 8,0 mm from the spine edge.

The cover shall be attached squarely and firmly to the book block after the application of spine and side glue (perfect binding or gluing-off).

The grain direction of the cover material should be parallel to the spine.

## 5 Binding quality control

### 5.1 General

There shall be immediate communication between parties on all irregularities occurring during the manufacturing of bound products. See also [4.1](#). It is recommended to verify the quality attributes, listed in [5.3](#), within standardized or customized quality assurance measures, as far as possible.

### 5.2 Sampling

Sampling should be performed on semi and final products. The sampling of final products should be performed according to either ISO 186 or ISO 2859-1.

### 5.3 Inspection of the final products

The binding quality of final products shall meet the specifications in the job information requirements. The following aspects shall be used even if not a part of the original job information requirements.

- a) The book block shall have form stability and a warping figure that is within tolerance for the standardized climatic conditions of the region of use. For measurement of warping, see Annex A. The warping degree measured should not exceed 2,0 mm per 100 mm of width.
- b) No excess of adhesive shall be visible on any part of the final product.
- c) All visible surfaces shall have no scratches or marks.

- d) The adhesion between the cover and the book block shall be strong enough to ensure that the attempt to remove the cover from the book block results in a rupture of the cover material.
- e) The adhesion of the spine glue shall be strong enough to ensure that no sheets separate from the book block under conditions of intended use.
- f) The content of the book block shall be as intended according to the order of pages and additions.
- g) The transition of charts, images, maps and text from page to page should meet accurately for reading; any deviation should not exceed 1,5 mm.

NOTE At this point in the process chain, it is impossible to correct this error. For an evaluation of this issue, semi products (signatures) are necessary.

- h) The trimmed edges shall be smooth and without knife marks or turned-over edges.
- i) The cover or book case shall be flat and without wrinkles, bubbles or damages.
- j) Case-bound books should have firm joints from the head to the tail and uniform squares on all edges. Covering material shall adhere squarely to the case boards and to the inlay.
- k) The endpapers should adhere to the case boards and the block without wrinkles and bubbles.
- l) Saddle-stitched brochures shall have staples positioned in the folding edge, and there shall be no cracked or misshaped staples.

## Annex A (normative)

### Method to measure degree of warping of finished products

#### A.1 General

Paper has a certain physical variability and is hydroscopic, any paper based products finished from binding processes shall not be delivered till they have become stable.

To obtain stability, the finished products, after going through all stages of process, shall be stacked in a place at a temperature of  $20\text{ °C} \pm 5\text{ °C}$  and a relative humidity between 35 % and 75 % for 24 h. The measurement of possible warping shall be taken after this handling period of time.

#### A.2 Measurement

If warping appears, it may cause either of the two following results in a finished product:

- the concave cover;
- the convex cover.

See [Figure A.1](#).

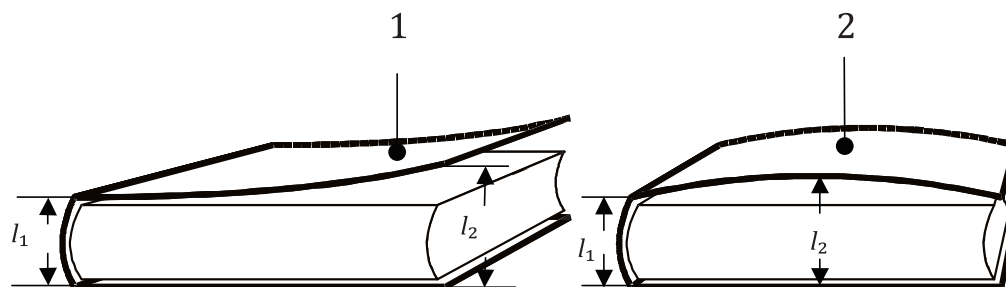

#### Key

- 1 concave cover
- 2 convex cover
- $l_1$  thickness of the spine
- $l_2$  length from the highest point of the concave or convex cover to the bottom

**Figure A.1 — Warping of a final product**

To determine the degree of warping in both ways, the first step is to measure the thickness of the spine ( $l_1$ ), then measure the length from the highest point of the concave or convex cover to the bottom ( $l_2$ ), see [Figure A.1](#). The difference between these two measured values ( $l_2 - l_1$ ) is the warping degree.



## Bibliography

- [1] ISO 186, *Paper and board — Sampling to determine average quality*
- [3] ISO 2859-1, *Sampling procedures for inspection by attributes — Part 1: Sampling schemes indexed by acceptance quality limit (AQL) for lot-by-lot inspection*
- [2] ISO 9706, *Information and documentation — Paper for documents — Requirements for permanence*
- [4] ISO 11800, *Information and documentation — Requirements for binding materials and methods used in the manufacture of books*
- [5] ISO 14416, *Information and documentation — Requirements for binding of books, periodicals, serials and other paper documents for archive and library use — Methods and materials*
- [6] ISO 12637-4, *Graphic technology — Vocabulary — Part 4: Postpress terms*
- [7] ANS/NISO/LBI Z39.78-2000, *Library Binding*
- [8] ABNT NBR 14869:2002, *Graphic Technology — Textbooks — Specifications*
- [9] ABNT NBR 15201-2006, *Printing technology — Textbooks — Classification of defects and testing methods*
- [10] TAGA Italia — TAGA.DOC.10 — *Linee Guida e raccomandazioni per le lavorazioni di legatoria*
- [11] Chinese Press and Publication Industry Standard, CY/T27-1999, *Quality requirements and inspection procedures for hard cover binding*
- [12] VISCOM *Richtlinien Verarbeitungsdifferenzen und Toleranzwerte in der Druckweiterverarbeitung*
- [13] KIPPHAN H. *Handbook of print media*. Springer, 2001





## Bureau of Indian Standards

BIS is a statutory institution established under the *Bureau of Indian Standards Act, 2016* to promote harmonious development of the activities of standardization, marking and quality certification of goods and attending to connected matters in the country.

### Copyright

BIS has the copyright of all its publications. No part of these publications may be reproduced in any form without the prior permission in writing of BIS. This does not preclude the free use, in the course of implementing the standard, of necessary details, such as symbols and sizes, type or grade designations. Enquiries relating to copyright be addressed to the Head (Publication & Sales), BIS.

### Review of Indian Standards

Amendments are issued to standards as the need arises on the basis of comments. Standards are also reviewed periodically; a standard along with amendments is reaffirmed when such review indicates that no changes are needed; if the review indicates that changes are needed, it is taken up for revision. Users of Indian Standards should ascertain that they are in possession of the latest amendments or edition by referring to the website-[www.bis.gov.in](http://www.bis.gov.in) or [www.standardsbis.in](http://www.standardsbis.in).

This Indian Standard has been developed from Doc No.: MSD 06 (23479).

### Amendments Issued Since Publication

Amend No.	Date of Issue	Text Affected

## BUREAU OF INDIAN STANDARDS

### Headquarters:

Manak Bhavan, 9 Bahadur Shah Zafar Marg, New Delhi 110002

Telephones: 2323 0131, 2323 3375, 2323 9402

Website: [www.bis.gov.in](http://www.bis.gov.in)

### Regional Offices:

Central : 601/A, Konnectus Tower -1, 6<sup>th</sup> Floor,  
DMRC Building, Bhavbhuti Marg, New  
Delhi 110002

Telephones

{ 2323 7617

Eastern : 8<sup>th</sup> Floor, Plot No 7/7 & 7/8, CP Block, Sector V,  
Salt Lake, Kolkata, West Bengal 700091

{ 2367 0012  
2320 9474

Northern : Plot No. 4-A, Sector 27-B, Madhya Marg,  
Chandigarh 160019

{ 265 9930

Southern : C.I.T. Campus, IV Cross Road, Taramani, Chennai 600113

{ 2254 1442  
2254 1216

Western : Manakalya, 4<sup>th</sup> Floor, NTH Complex (W Sector), F-10, MIDC, Andheri  
(East), Mumbai 400093

{ 283 25838

**Branches :** AHMEDABAD, BENGALURU, BHOPAL, BHUBANESHWAR, CHANDIGARH, CHENNAI, COIMBATORE, DEHRADUN, DELHI, FARIDABAD, GHAZIABAD, GUWAHATI, HARYNA, HUBLI, HYDERABAD, JAIPUR, JAMMU & KASHMIR, JAMSHEDPUR, KOCHI, KOLKATA, LUCKNOW, MADURAI, MUMBAI, NAGPUR, NOIDA, PARWANOO, PATNA, PUNE, RAIPUR, RAJKOT, SURAT, VIJAYAWADA.