प्लेन बियरिंग्स — धात्विक बहुपरतीय प्लेन
बियरिंग्स

भाग 2 2 मिमी या ज्यादा मोटे बियरिंग
धातुपरत के बॉन्ड का विनाशकारी परीक्षण
(पहला पुनरीक्षण)

**Plain Bearings — Metallic Multilayer
Plain Bearings**
**Part 2 Destructive Testing of Bond for
Bearing Metal Layer Thicknesses Greater
than or Equal to 2 mm**
(*First Revision*)

ICS 21.100.10

© BIS 2024
© ISO 2019



भारतीय मानक ब्यूरो
BUREAU OF INDIAN STANDARDS
मानक भवन, 9 बहादुर शाह ज़फर मार्ग, नई दिल्ली - 110002
MANAK BHAVAN, 9 BAHADUR SHAH ZAFAR MARG
NEW DELHI - 110002
www.bis.gov.in www.standardsbis.in

NATIONAL FOREWORD

This Indian Standard (Part 2) (First Revision) which is identical to ISO 4386-2 : 2019 'Plain bearings — Metallic multilayer plain bearings — Part 1: Destructive testing of bond for bearing metal layer thicknesses greater than or equal to 2 mm' issued by the International Organization for Standardization (ISO) was adopted by the Bureau of Indian Standards on the recommendation of the Bearing Sectional Committee and approval of the Production and General Engineering Division Council.

This standard was first published in 2019. In this revision of this standard has been undertaken to align it with the current version of ISO 4386-2.

The major changes incorporated in this revision are:

- a) A new clause on terms and definitions has been added;
- b) The test apparatus has been modified to reduce the negative local bending stress influence on the specimen;
- c) The geometry of the test specimen has been modified to avoid negative influence due to tolerances;
- d) A description of the specimen machining sequence has been added to get a more uniform specimen; and
- e) A subclause on the application for quality control has been added.

This standard has been published in three parts. The other parts in this series are:

- | | |
|--------|---|
| Part 1 | Non-destructive ultrasonic testing of bond of thickness greater than or equal to 0.5 mm |
| Part 3 | Non-destructive penetrant testing |

The text of ISO Standard has been approved as suitable for publication as an Indian Standard without deviations. Certain conventions are, however, not identical to those used in Indian Standards. Attention is particularly drawn to the following:

- a) Wherever the words 'International Standard' appear referring to this standard, they should be read as 'Indian Standard'; and
- b) Comma (,) has been used as a decimal marker while in Indian Standards, the current practice is to use a point (.) as the decimal marker.

For the purpose of deciding whether a particular requirement of this standard is complied with, the final value, observed or calculated expressing the result of a test or analysis, shall be rounded off in accordance with IS 2 : 2022 'Rules for rounding off numerical values (*second revision*).' The number of significant places retained in the rounded off value should be the same as that of the specified value in this standard.

Contents

Page

Introduction	iv
1 Scope	1
2 Normative references	1
3 Terms and definitions	1
4 Principle	1
5 Test equipment	2
5.1 General.....	2
5.2 Testing apparatus.....	2
6 Specimen	3
6.1 General.....	3
6.2 Specimen machining sequence.....	4
7 Procedure	5
8 Evaluation	6
8.1 General.....	6
8.2 Designation.....	7
8.3 Test report.....	7
9 Application for quality control and process qualification	8
9.1 General.....	8
9.2 Quality control.....	8
9.3 Process qualification.....	8
Bibliography	10

Introduction

Long years of experience with bond tests led to an adaptation of this document. The test apparatus has been modified to reduce the negative local bending stress influence on the specimen. The geometry of the test specimen has been modified to avoid negative influence due to tolerances. A description of the specimen machining sequence has been added to get a more uniform specimen. A subclause on the application for quality control has been added.

Indian Standard

PLAIN BEARINGS — METALLIC MULTILAYER PLAIN BEARINGS

**PART 2 DESTRUCTIVE TESTING OF BOND FOR BEARING METAL
LAYER THICKNESSES GREATER THAN OR EQUAL TO 2 MM**

(*First Revision*)

1 Scope

This document specifies a tensile test method for determination of the bond strength between the bearing metal and the backing. The test can be applied to multilayer plain bearings with bearing metals based on lead, tin, copper or aluminium. For tested layer thicknesses ≥ 2 mm, a raw lining thickness of a minimum additional 1 mm is necessary.

The backings are from steel, cast steel or copper alloys. The bond strength test does not apply to bearings with cast iron backing.

The test applies to all thrust bearings and to journal bearings with an inner diameter of backing ≥ 90 mm.

The test can be used for comparative investigations into the influence on the bond strength of various processes and types of material. In addition, the test is suitable for production control and for process qualification of bearing production.

For non-destructive ultrasonic testing of the bond between bearing metal and backing for bearing metal layer thicknesses ≥ 2 mm, see ISO 4386-1.

2 Normative references

There are no normative references in this document.

3 Terms and definitions

No terms and definitions are listed in this document.

ISO and IEC maintain terminological databases for use in standardization at the following addresses:

- ISO Online browsing platform: available at <https://www.iso.org/obp>
- IEC Electropedia: available at <http://www.electropedia.org/>

4 Principle

During the tensile testing carried out vertically to the bond surface, the bond strength, R_{Ch} , in newtons per square millimetre, is the quotient of the maximum force, F_{max} , in newtons and the bond surface, A , in square millimetres, of the specimen (see [Table 2](#)), as given by [Formula \(1\)](#).

NOTE The subscript "Ch" refers to the test method proposed by Chalmers.

$$R_{Ch} = \frac{F_{max}}{A} \quad (1)$$

5 Test equipment

5.1 General

A calibrated tensile testing machine shall be used with apparatus in accordance with [Table 1](#).

By means of careful adjustment of the apparatus, it shall be ensured that the force is acting vertically to the bond surface in order to avoid incorrect measurements.

5.2 Testing apparatus

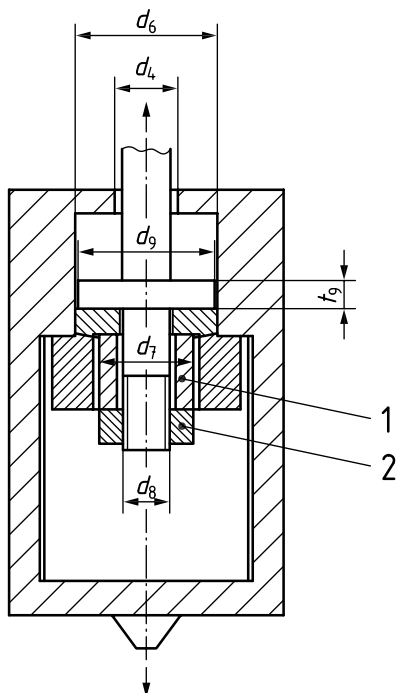

Key

- 1 distance tube
- 2 nut

Figure 1 — Main dimensions of apparatus

NOTE Details not indicated in this document are expected to be chosen accordingly.

Table 1 — Dimensions and tolerances for test apparatus

Dimensions in millimetres

Type of specimen	Apparatus geometry data					
	d_4	d_6	d_7	d_8	d_9	t_9
	$\begin{matrix} +0,1 \\ 0 \end{matrix}$	$\begin{matrix} +0,1 \\ 0 \end{matrix}$	$\begin{matrix} 0 \\ -0,1 \end{matrix}$	NA	NA	NA
T 100	8,1	19,8	15,9	M 8	19	4
T 200	12,1	29,1	23,9	M 12	28	4
NA: not applicable						

6 Specimen

6.1 General

Tin casting alloys for multilayer plain bearings are specified in ISO 4381.

For selection of the type of specimen in the case of journal bearings, the inner diameter, d_1 , of the bearing has to be considered.

Specimen T 100 is valid from the minimum diameter $d_1 = 90$ mm up to $d_1 = 200$ mm.

Specimen T 200 is valid for all diameters $d_1 > 200$ mm.

For the thrust bearing specimens, T 100 and T 200 may be used. Whenever possible, T 200 should be preferred.

Both bearing metal faces shall be machined as a precondition for fixing the bearing metal layer on the test apparatus to avoid bending deformation of the bearing metal during test procedure. Use test apparatus in accordance with [Table 1](#).

Specimens shall be manufactured in accordance with [Table 2](#), [Figure 2](#) and [5.1](#).

Table 2 — Dimensions and tolerances for specimens (see [Figure 2](#))

Dimensions in millimetres

Type of specimen	Bond surface A mm ²	Inner diameter of the backing of journal bearing d_1	Specimen geometry data			
			d_2 h8	d_3 H8	d_4 $\begin{matrix} +0,1 \\ 0 \end{matrix}$	d_5
T 100	100	90 - 200	19,60	16	8,1	29
T 200	200	>200	28,85	24	12,1	38

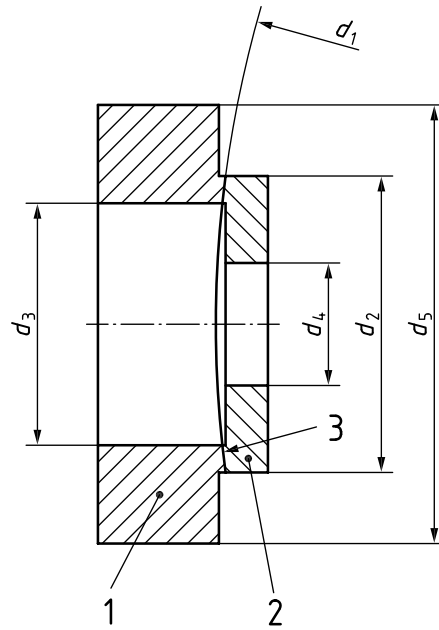

Key

- 1 backing
- 2 bearing metal
- 3 bond surface equal to test surface

Figure 2 — Specimen (from a journal bearing) for bond testing

6.2 Specimen machining sequence

Table 3 — Specimen machining sequence

<p>Step 1:</p> <ul style="list-style-type: none"> a) Tighten raw specimen with bearing metal towards chuck. b) Machine d_5. c) Machine backing front plane to thickness Z. 		<p>T 100</p>	<p>T 200</p>
<p>Key</p> <ul style="list-style-type: none"> a Before machining. b After machining. <p>Figure 3 — Step 1</p>		<p>$d_5 = 29$ $Z = 8 - 10$</p>	<p>$d_5 = 38$ $Z = 10 - 12$</p>

Table 3 (continued)

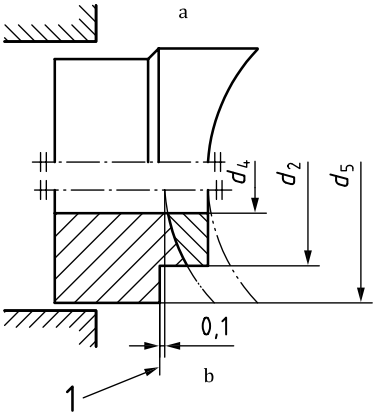
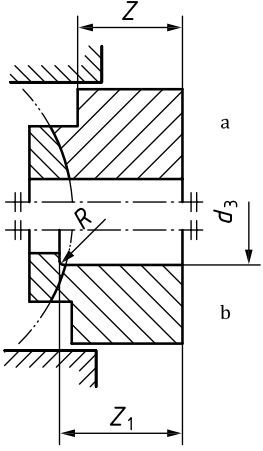
<p>Step 2:</p> <p>a) Reverse specimen and tighten with backing towards chuck.</p> <p>b) Drill d_4.</p> <p>c) Machine d_5. Machine d_2. Machine the reference plane 0,1 mm deep into the steel, referred to the deepest point of bond surface.</p> <p>d) Machine bearing metal front face plane. The raw lining thickness shall be min. 3 mm.</p>	 <p>Key 1 reference plane a Before machining. b After machining.</p> <p>Figure 4 — Step 2</p>	$d_4 = 8,1^{+0,1}_0$ $d_5 = 29$ $d_2 = 19,60 \text{ h8}$	$d_4 = 12,1^{+0,1}_0$ $d_5 = 38$ $d_2 = 28,85 \text{ h8}$
<p>Step 3:</p> <p>a) Reverse specimen and tighten with bearing metal towards chuck.</p> <p>b) Machine d_3 with depth Z_1. Radius $R = 0,1$ mm.</p>	 <p>Key a Before machining. b After machining.</p> <p>Figure 5 — Step 3</p>	$d_3 = 16,0 \text{ H8}$ $Z_1^{+0,1}_0 = Z + 0,9$	$d_3 = 24,0 \text{ H8}$ $Z_1^{+0,1}_0 = Z + 0,9$

7 Procedure

The apparatus, as shown in [Figure 1](#), is mounted on the calibrated tensile testing machine. Subsequently, the specimen is locked into the apparatus, whereas the bearing metal surfaces are fixed to avoid local bending. For that purpose, hand tighten the nut (see [Figure 1](#)).

The force is steadily increased until the specimen fractures.

The increase in stress should be at about 10 N/mm² per second.

The force of the specimen fracture is read from the testing machine.

8 Evaluation

8.1 General

With the aid of the force of failure, F_{\max} , found necessary to tear the bearing metal away from the backing in the region of the bond surface, the bond strength, R_{Ch} , is to be determined according to [Formula \(1\)](#). Previous existing local bond defects on the surface of failure shall be noted.

The characteristic limiting value of layer thickness for the absolute bond strength is a property of the bearing metal. It is 6 mm for Pb and Sn alloys. For other than Pb and Sn alloys, the value shall be determined in a series of tests with different thicknesses of the bearing material layers. Above the limit, the results are independent of the layer thickness.

Absolute bond strength is given when the layer thickness is greater than or equal to the characteristic limiting value of thickness. The result is independent of the layer thickness of the bearing metal.

Relative bond strength is given when the layer thickness is less than the characteristic limiting value of thickness. For layer thicknesses below the limiting value of thickness, it has been established experimentally that the relative bond strength drops linearly to the value zero (see [Figure 6](#)).

The evaluation procedure is as follows:

- a) layer thickness greater than or equal to characteristic limiting value of thickness: the value found is the absolute bond strength value;
- b) layer thickness less than characteristic limiting value of thickness: the value found is the relative bond strength value and has to be converted into the value of the absolute bond strength as shown in [Figure 6](#) (as an example).

All results of absolute bond strength shall be limited to the tensile strength, R_m , of the tested bearing metal.

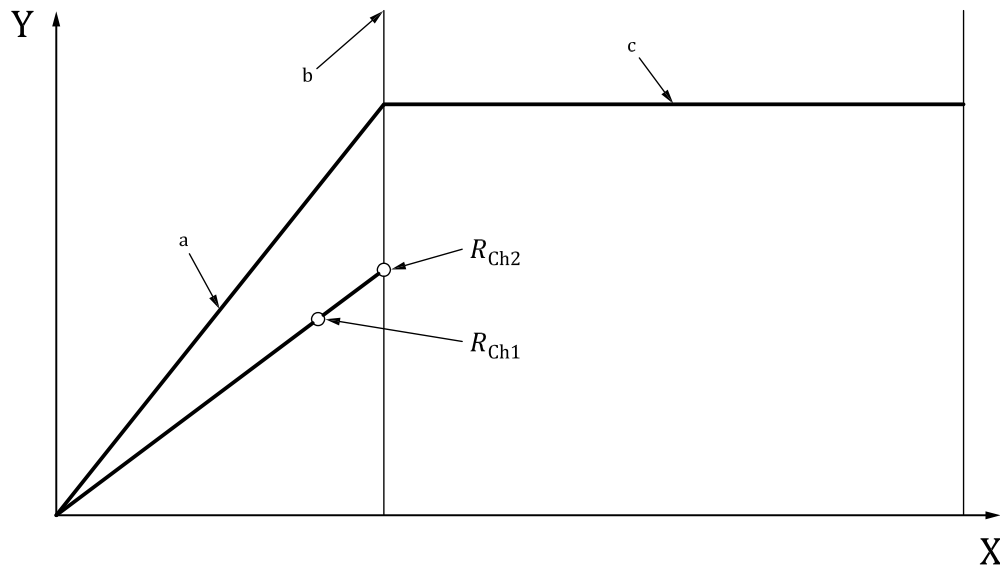

Key

X	thickness of bearing metal layer
Y	bond strength
a	Relative bond strength.
b	Limiting value.
c	Absolut. bond strength.
R_{Ch1}	measured value in the range of the relative bond strength
R_{Ch2}	value of the absolute bond strength determined graphically

Figure 6 — Principle curve of the bond strength as a function of the thickness of the bearing metal layer

8.2 Designation

With reference to this document, the tensile test (represented by T) shall be indicated as follows:

Test ISO 4386-2 followed by "T" and test surface

EXAMPLE A test surface of 200 mm² is designated as follows: **Test ISO 4386-2 - T 200**

8.3 Test report

A test report on the result of the test shall be drawn up (by agreement).

In the test report, the following shall be indicated:

- reference to this document, i.e. ISO 4386-2:2019;
- reference to the tested plain bearing;
- dimensions, layer thickness and materials of the plain bearing;
- type of specimen, for example T 200;
- number of specimens;
- for each specimen:
 - maximum force applied until fracture of the specimen;

- relative and absolute bond strength determined;
 - description of the condition of the fractured surface inclusive of detected local bond defects or porosities;
- g) summary of a test series:
- mean value of absolute bond strength;
 - maximum absolute bond strength;
 - minimum absolute bond strength;
- h) test personnel and date of test.

9 Application for quality control and process qualification

9.1 General

The bond strength depends on many influences, such as backing material quality, heat treatment of backing material, preparation of bond surface, bearing metal composition, casting temperature, backing temperature, backing geometry, cooling conditions, specimen machining tolerances and the test procedure itself.

Because of all these influences, in practice, bond strength results can vary. Less variation of results of a tested series is an indication for high uniformity in processing.

A sufficient number of specimens shall be taken from the test bearing. Specimens should be taken from the centre area of the bearing as well as from the area near the border and should be marked accordingly.

A test with a single specimen gives no quality indication. For a quality indication, the mean value of a series of tests shall be taken.

9.2 Quality control

Through this test procedure, the bearing is usually destroyed. Therefore, this test procedure is not applicable to continuous quality control. In mass production, a single bearing can be immolated each time.

In single-part production, a separate bearing of the same materials and same geometry shall be produced in sequence with the original bearing, and specimens are to be taken from this separate bearing. Only this approach ensures comparable bond conditions on both bearings.

A mean value of absolute bond $\geq 0,6 R_m$ (tensile strength) of the bearing metal is a sufficient bond for plain bearings.

9.3 Process qualification

A process qualification can be carried out on a typical bearing of the production range.

The mean value of an absolute bond $\geq 0,8 R_m$ (tensile strength) of the bearing metal is a desirable bond for process qualification.

The associated processing data shall be documented and shall be used in the future for the tested bearing type. When dimensions, geometry or materials are to be modified, the process qualification shall be repeated under the new conditions.

NOTE A frequent reason for low bond is a processing temperature that is too low due to local temperature losses.

If the recommended bond cannot be achieved, the heating and cooling conditions of the lining process shall be improved or a different lining process shall be chosen.

Bibliography

ISO 4381, *Plain bearings — Tin casting alloys for multilayer plain bearings*

Bureau of Indian Standards

BIS is a statutory institution established under the *Bureau of Indian Standards Act, 2016* to promote harmonious development of the activities of standardization, marking and quality certification of goods and attending to connected matters in the country.

Copyright

BIS has the copyright of all its publications. No part of these publications may be reproduced in any form without the prior permission in writing of BIS. This does not preclude the free use, in the course of implementing the standard, of necessary details, such as symbols and sizes, type or grade designations. Enquiries relating to copyright be addressed to the Head (Publication & Sales), BIS.

Review of Indian Standards

Amendments are issued to standards as the need arises on the basis of comments. Standards are also reviewed periodically; a standard along with amendments is reaffirmed when such review indicates that no changes are needed; if the review indicates that changes are needed, it is taken up for revision. Users of Indian Standards should ascertain that they are in possession of the latest amendments or edition by referring to the website-www.bis.gov.in or www.standardsbis.in.

This Indian Standard has been developed from Doc No.: PGD 13 (23235).

Amendments Issued Since Publication

Amend No.	Date of Issue	Text Affected

BUREAU OF INDIAN STANDARDS

Headquarters:

Manak Bhavan, 9 Bahadur Shah Zafar Marg, New Delhi 110002

Telephones: 2323 0131, 2323 3375, 2323 9402

Website: www.bis.gov.in

Regional Offices:

Central : 601/A, Konnectus Tower -1, 6th Floor,
DMRC Building, Bhavbhuti Marg, New
Delhi 110002

Telephones

{ 2323 7617

Eastern : 8th Floor, Plot No 7/7 & 7/8, CP Block, Sector V,
Salt Lake, Kolkata, West Bengal 700091

{ 2367 0012
2320 9474

Northern : Plot No. 4-A, Sector 27-B, Madhya Marg,
Chandigarh 160019

{ 265 9930

Southern : C.I.T. Campus, IV Cross Road, Taramani, Chennai 600113

{ 2254 1442
2254 1216

Western : Manakalya, 4th Floor, NTH Complex (W Sector), F-10, MIDC, Andheri
(East), Mumbai 400093

{ 283 25838

Branches : AHMEDABAD, BENGALURU, BHOPAL, BHUBANESHWAR, CHANDIGARH, CHENNAI, COIMBATORE, DEHRADUN, DELHI, FARIDABAD, GHAZIABAD, GUWAHATI, HARYNA, HUBLI, HYDERABAD, JAIPUR, JAMMU & KASHMIR, JAMSHEDPUR, KOCHI, KOLKATA, LUCKNOW, MADURAI, MUMBAI, NAGPUR, NOIDA, PARWANOO, PATNA, PUNE, RAIPUR, RAJKOT, SURAT, VIJAYAWADA.