

धात्विक सामग्रियाँ — बंक परिक्षण
(पांचवाँ पुनरीक्षण)

Metallic Materials — Bend Test
(*Fifth Revision*)

ICS 77.040.10

© BIS 2023
© ISO 2020



भारतीय मानक ब्यूरो
BUREAU OF INDIAN STANDARDS
मानक भवन, 9 बहादुर शाह ज़फर मार्ग, नई दिल्ली - 110002
MANAK BHAVAN, 9 BAHADUR SHAH ZAFAR MARG
NEW DELHI - 110002
www.bis.gov.in www.standardsbis.in

NATIONAL FOREWORD

This Indian Standard (Fifth Revision) which is identical to ISO 7438 : 2020 'Metallic materials — Bend test' issued by the International Organization for Standardization (ISO) was adopted by the Bureau of Indian Standards on the recommendation of the Mechanical Testing of Metals Sectional Committee and approval of the Metallurgical Engineering Division Council.

This standard was first published in 1960 and subsequently revised in 1974, 1985, 2012 and 2019. The fifth revision of this standard has been undertaken to align with the latest version ISO 7438 : 2020 to harmonize it with the latest developments that have taken place at international level.

The main change compared to the previous edition is the addition of new Annex B, describing bending test at plane strain condition.

The text of ISO standard has been approved as suitable for publication as in Indian Standard without deviations. Certain terminologies and conventions are, however, not identical with those used in Indian Standard. Attention is especially drawn to the following:

- a) Wherever the words 'International Standard' appear referring to this standard, it should be read as 'Indian Standard'; and
- b) Comma (,) has been used as a decimal marker while in Indian Standards the current practice is to use a point (.) as the decimal marker.

In reporting the result of a test or analysis made in accordance with this standard, is to be rounded off, it shall be done in accordance with IS 2 : 2022 'Rules for rounding off numerical-values (second revision)'.
(*second revision*)'.

Contents

Page

1	Scope	1
2	Normative references	1
3	Terms and definitions	1
4	Symbols, designations and units	1
5	Principle	2
6	Test equipment	2
6.1	General.....	2
6.2	Bending device with supports and a former.....	4
6.3	Bending device with a V-block.....	4
6.4	Bending device with a clamp.....	4
7	Test piece	4
7.1	General.....	4
7.2	Edges of rectangular test pieces.....	4
7.3	Width of the test piece.....	5
7.4	Thickness of the test piece.....	5
7.5	Test pieces from forgings, castings and semi-finished products.....	5
7.6	Agreement for test pieces of greater thickness and width.....	5
7.7	Length of the test piece.....	5
8	Procedure	6
9	Interpretation of results	7
10	Test report	7
	Annex A (informative) Determination of the bend angle from the measurement of the displacement of the former	8
	Annex B (normative) Bend test at plane strain conditions	9
	Bibliography	13

Indian Standard
METALLIC MATERIALS — BEND TEST
(*Fifth Revision*)

1 Scope

This document specifies a method for determining the ability of metallic materials to undergo plastic deformation in bending.

This document applies to test pieces taken from metallic products, as specified in the relevant product standard. It is not applicable to certain materials or products, for example tubes in full section or welded joints, for which other standards exist.

2 Normative references

There are no normative references in this document.

3 Terms and definitions

No terms and definitions are listed in this document.

ISO and IEC maintain terminological databases for use in standardization at the following addresses:

- IEC Electropedia: available at <http://www.electropedia.org/>
- ISO Online browsing platform: available at <https://www.iso.org/obp>

4 Symbols, designations and units

Symbols and designations used in the bend test are shown in [Figures 1](#) and [2](#) and specified in [Table 1](#).

Table 1 — Symbols, designations and units

Symbol	Designation	Unit
a	Thickness or diameter of test piece (or diameter of the inscribed circle for pieces of polygonal cross-section)	mm
b	Width of the test piece	mm
c	Distance between the plane including the horizontal axis of supports and the central axis of the rounded portion of the former before test	mm
D	Diameter of the former	mm
f	Displacement of the former	mm
$\bar{\theta}$	Lode angle parameter, i.e. strain path direction	—
L	Length of the test piece	mm
l	Distance between supports	mm
η	Triaxiality factor	—
p	Distance between the vertical planes including the central axis of each support and the vertical plane including the central axis of the former	mm
R	Radius of the supports	mm
r	Internal radius of bend portion of test piece after bending	mm
α	Angle of bend	degrees

5 Principle

The bend test consists of submitting a test piece of round, square, rectangular or polygonal cross-section to plastic deformation by bending, without changing the direction of loading, until a specified angle of bend is reached.

The axes of two legs of the test piece remain in a plane perpendicular to the axis of bending. In the case of a 180° bend, the two lateral surfaces may, depending on the requirements of the product standard, lie flat against each other or can be parallel at a specified distance, an insert being used to control this distance.

6 Test equipment

6.1 General

The bend test shall be carried out in testing machines or presses equipped with the following devices:

- bending device with two supports and a former as shown in [Figure 1](#);
- bending device with a V-block and a former as shown in [Figure 2](#);
- bending device with a clamp as shown in [Figure 3](#).

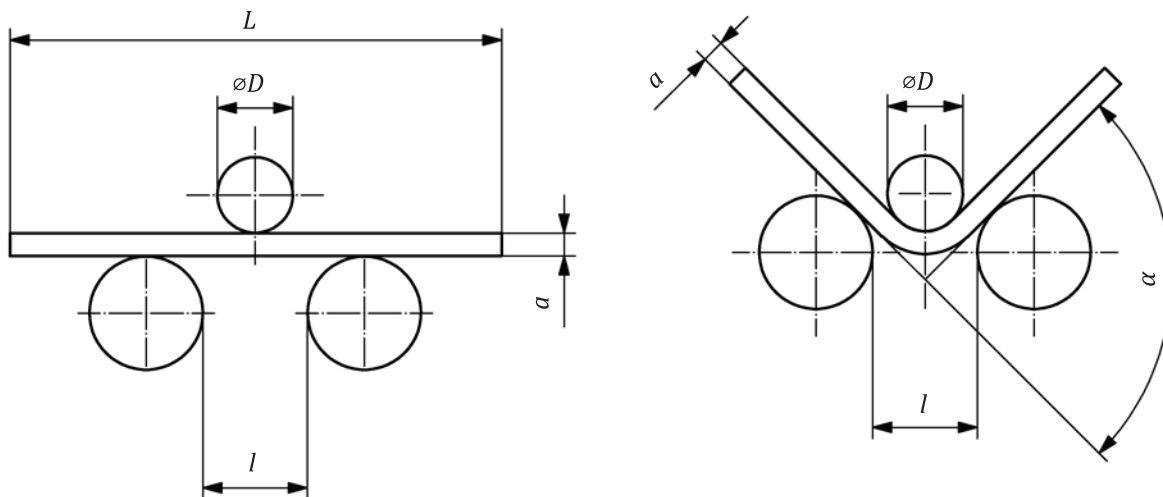

Figure 1 — Bending device with two supports and a former

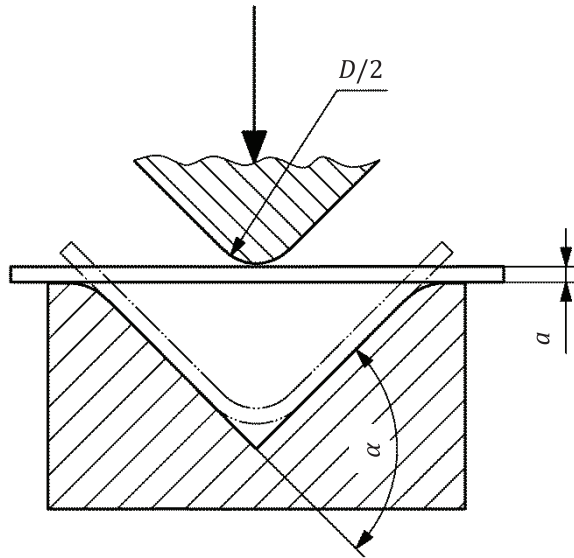
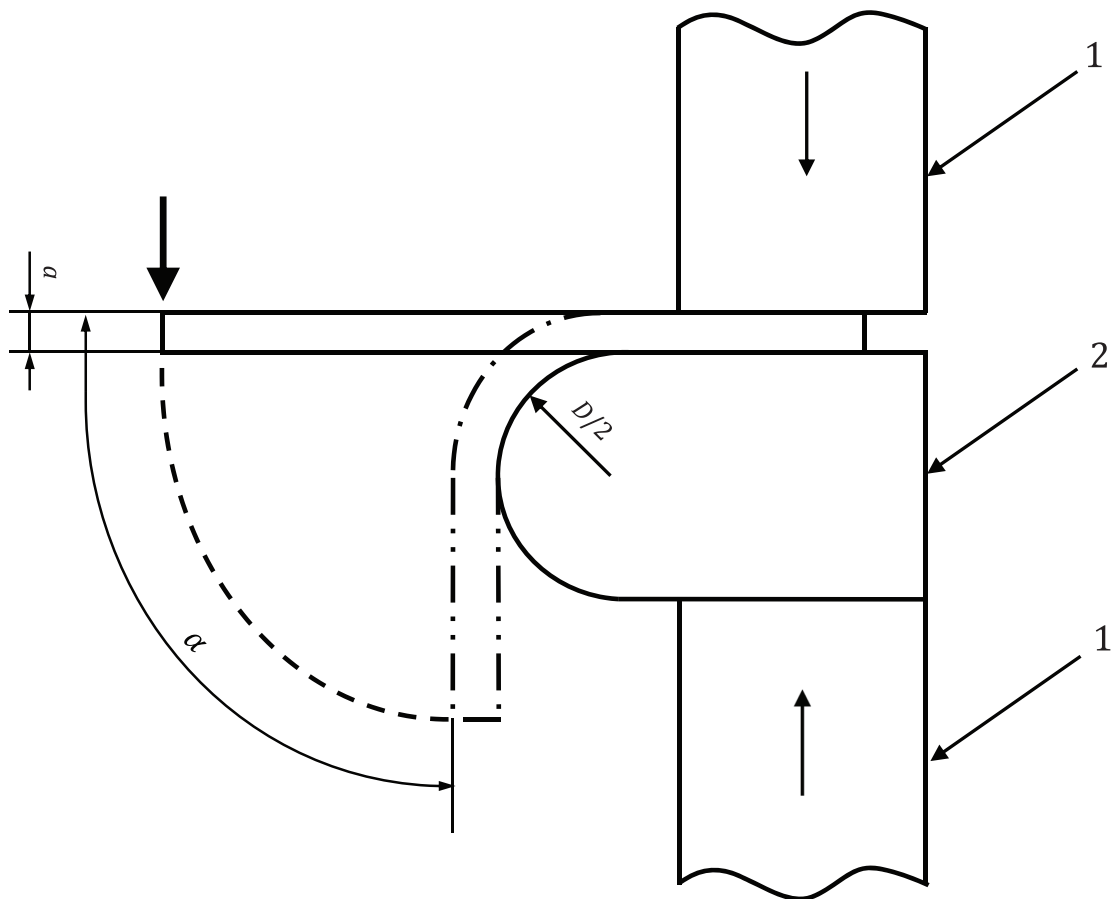

Figure 2 — Bending device with a V-block and a former



Key

- 1 clamp
- 2 former

Figure 3 — Bending device with a clamp

6.2 Bending device with supports and a former

6.2.1 The length of the supports and the width of the former shall be greater than the width or diameter of the test piece. The diameter of the former is determined by the product standard (see [Figure 1](#)). The test piece supports and the former shall be of sufficient hardness.

6.2.2 Unless otherwise specified, the distance between the supports, l , shall be as given in [Formula \(1\)](#), and shall not change during the bend test.

$$l=(D+3a)\pm\frac{a}{2} \quad (1)$$

NOTE When the distance between the supports, l_2 , is specified as smaller than or equal to $D + 2a$, it can result in clamping during the test and stretch forming of the test piece.

6.3 Bending device with a V-block

The tapered surfaces of the V-block shall form an angle of $180^\circ - \alpha$ (see [Figure 2](#)). The angle α is specified in the relevant standard.

The edges of the V-block shall have a radius between 1 and 10 times the thickness of the test piece and shall be of sufficient hardness.

6.4 Bending device with a clamp

The device consists of a clamp and a former of sufficient hardness. It may be equipped with a lever for applying force to the test piece (see [Figure 3](#)).

Because the position of the left face of the clamp can influence the test results, the left face of the clamp (as shown in [Figure 3](#)) should not reach up to or beyond the vertical line through the centre of the circular former shape.

7 Test piece

7.1 General

Round, square, rectangular or polygonal cross-section test pieces shall be used in the test. Any areas of the material affected by shearing or flame cutting and similar operations during the sampling of test pieces shall be removed. However, testing a test piece, the affected parts of which have not been removed, is acceptable, provided that the result is satisfactory.

7.2 Edges of rectangular test pieces

The edges of rectangular test pieces shall be rounded to a radius not exceeding the following values:

- 3 mm, when the thickness of the test pieces is 50 mm or greater;
- 1,5 mm, when the thickness of the test pieces is less than 50 mm and more than or equal to 10 mm;
- 1 mm when the thickness is less than 10 mm.

The rounding shall be made so that no transverse burrs, scratches or marks are formed which can adversely affect the test results. However, testing a test piece, the edges of which have not been rounded, is acceptable, provided that the result is satisfactory.

7.3 Width of the test piece

Unless otherwise specified in the relevant standard, the width of the test piece shall be as follows:

- a) the same as the product width, if the latter is equal to or less than 20 mm;
- b) when the width of a product is more than 20 mm:
 - 1) (20 ± 5) mm for products of thickness less than 3 mm;
 - 2) between 20 mm and 50 mm for products of thickness equal to or greater than 3 mm.

If it is agreed between the parties that plane strain conditions (plane strain definition is explained in [Annex B](#)) shall be maintained for test pieces greater than 3 mm thick, then the bend test shall be carried out in accordance with [Annex B](#).

7.4 Thickness of the test piece

7.4.1 The thickness of test pieces from sheets, strips and sections shall be equal to the thickness of the product to be tested. If the thickness of the product is greater than 25 mm, it may be reduced by machining one surface to attain a thickness not less than 25 mm. During bending, the unmachined side shall be on the tension-side surface of the test piece.

7.4.2 Test pieces of round or polygonal cross-section shall have a cross-section equal to that of the product, if the diameter (for a round cross-section) or inscribed circle diameter (for a polygonal cross-section) does not exceed 30 mm. When the diameter or the inscribed circle diameter of the test piece exceeds 30 mm up to and including 50 mm, it may be reduced to not less than 25 mm. When the diameter or inscribed circle diameter exceeds 50 mm, it shall be reduced to not less than 25 mm (see [Figure 4](#)). During bending, the unmachined side shall be on the tension-side surface of the test piece.

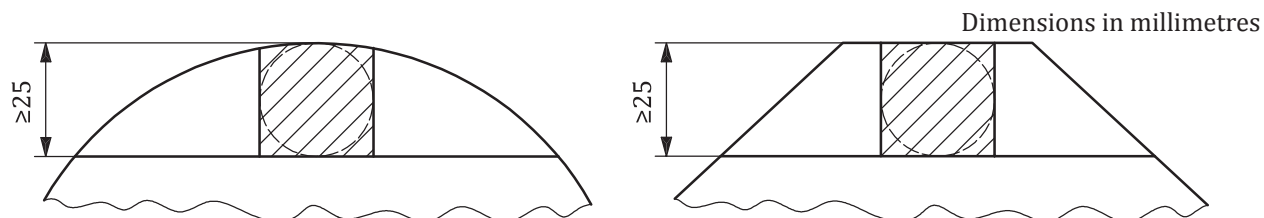

Figure 4 — Diameter and inscribed circle diameter of the test piece

7.5 Test pieces from forgings, castings and semi-finished products

In the case of forgings, castings and semi-finished products, the dimensions of the test piece and sampling shall be as defined in the general delivery requirements, or by agreement.

7.6 Agreement for test pieces of greater thickness and width

By agreement, test pieces of a greater width and thickness than those specified in [7.3](#) and [7.4](#) may be subjected to the bend test.

7.7 Length of the test piece

The length of the test piece depends on the thickness of the test piece and the test equipment used.

8 Procedure

WARNING — During the test, adequate safety measures and guarding equipment shall be provided.

8.1 In general, tests are carried out at ambient temperature between 10 °C and 35 °C. Tests carried out under controlled conditions, where required, shall be made at a temperature of (23 ± 5) °C.

8.2 The bend test shall be carried out using one of the following methods as specified in the relevant standard:

- a) a specified angle of bend is achieved under an appropriate force and for the given conditions (see [Figures 1, 2 and 3](#));
- b) the legs of the test piece are parallel to each other at a specified distance apart while under an appropriate force (see [Figure 6](#));
- c) the legs of the test piece are in direct contact while under an appropriate force (see [Figure 7](#)).

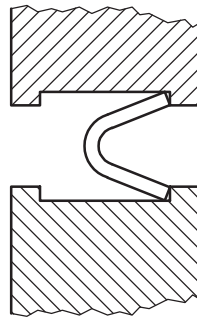

Figure 5 — Bending the legs of the test piece

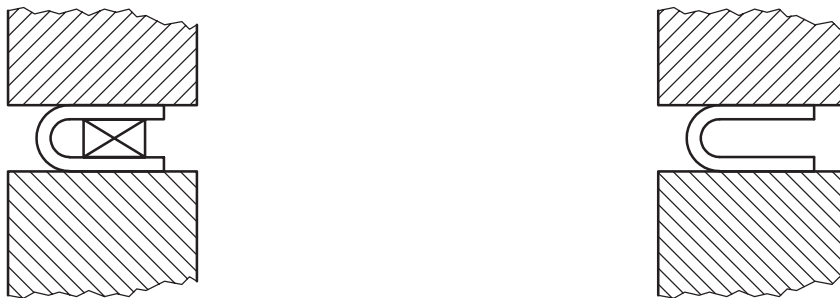

Figure 6 — Legs of the test piece parallel to each other

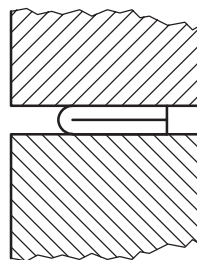

Figure 7 — Legs of the test piece in direct contact

8.3 In the bend test to a specified angle of bend, the test piece shall be placed on the supports (see [Figure 1](#)) or on the V-block (see [Figure 2](#)) and bent in the middle between supports by the action of a force. The angle of bend, α , can be calculated from the measurement of the displacement of the former as given in [Annex A](#).

For the three methods ([Figures 1, 2 and 3](#)), the bending force shall be applied slowly so as to permit free plastic flow of the material.

In case of dispute, the rate of displacement of the former shall be $(1 \pm 0,2)$ mm/s.

If it is not possible to bend the test piece directly to the specified angle in the manner described above, the bend shall be completed by pressing directly on the ends of the legs of the test piece (see [Figure 5](#)).

In a bend test requiring parallel legs, the test piece may be bent first, as indicated in [Figure 5](#), and then placed between the parallel plates of the press (see [Figure 6](#)), where it is further formed by application of a force to obtain parallelism of the legs. The test may be carried out with or without an insert. The thickness of the insert shall be as defined in the relevant standard or by agreement.

An alternate method of test is that of bending over a former (see [6.4](#)).

8.4 If specified, the test piece, after its preliminary bending, shall be further bent between the parallel plates of the press, by application of a force, to obtain direct contact between the legs of the test piece (see [Figure 7](#)).

9 Interpretation of results

9.1 The interpretation of the bend test shall be carried out according to the requirements of the product standard. When these requirements are not specified, absence of cracks visible without the use of magnifying aids is considered as evidence that the test piece withstood the bend test.

9.2 The angle of bend, specified in product standards, is always considered as a minimum. If the internal radius of a bend is specified, it is considered as a maximum.

NOTE The existence of an oxide layer on the unmachined surface on the tension side of the bend test piece has an influence on the judgment of the results. This point can be considered by the product standard or the parties concerned.

10 Test report

The test report shall include the following information:

- a) a reference to this document, i.e. ISO 7438;
- b) identification of the test piece (type of material, cast number, direction of the test piece axis relative to a product, etc.);
- c) the shape and dimensions of the test piece;
- d) the test method used;
- e) any deviation from this document;
- f) the test result.

Annex A (informative)

Determination of the bend angle from the measurement of the displacement of the former

This annex specifies the determination of the bend angle, α , of a test piece under force. The direct measurement of this angle is complicated. For this reason, the method of calculation of this angle from the measurement of the displacement, f , of the former is proposed. The bend angle, α , of the test piece under force can be determined from the displacement of the former and the values given in [Figure A.1](#), as per [Formulae \(A.1\)](#) to [\(A.4\)](#):

$$\sin \frac{\alpha}{2} = \frac{p \times c + W \times (f - c)}{p^2 + (f - c)^2} \quad (\text{A.1})$$

$$\cos \frac{\alpha}{2} = \frac{W \times p - c \times (f - c)}{p^2 + (f - c)^2} \quad (\text{A.2})$$

where

$$W = \sqrt{p^2 + (f - c)^2 - c^2} \quad (\text{A.3})$$

$$c = R + a + \frac{D}{2} \quad (\text{A.4})$$

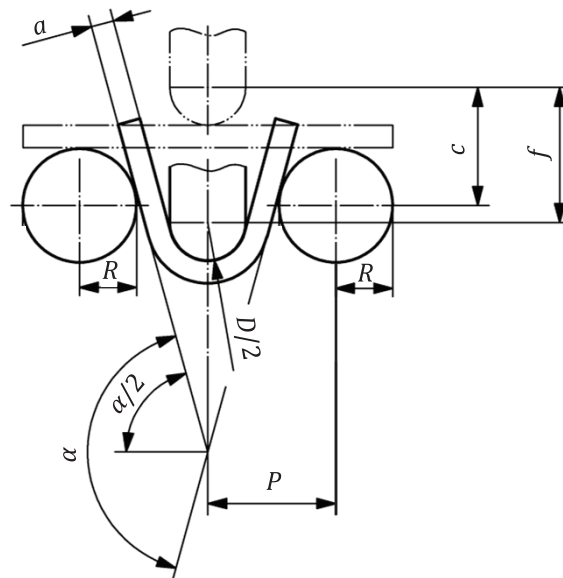

Figure A.1 — Values for the calculation of the bend angle, α

Annex B (normative)

Bend test at plane strain conditions

B.1 Overview

The use of this annex shall be agreed by involved parties.

The different combinations of thickness and width from 7.3 [a), b)] and the condition for plane strain are shown in Figure B.1 as a guide for selecting test piece width. The line in bold is separating plane strain from non-plane strain conditions.

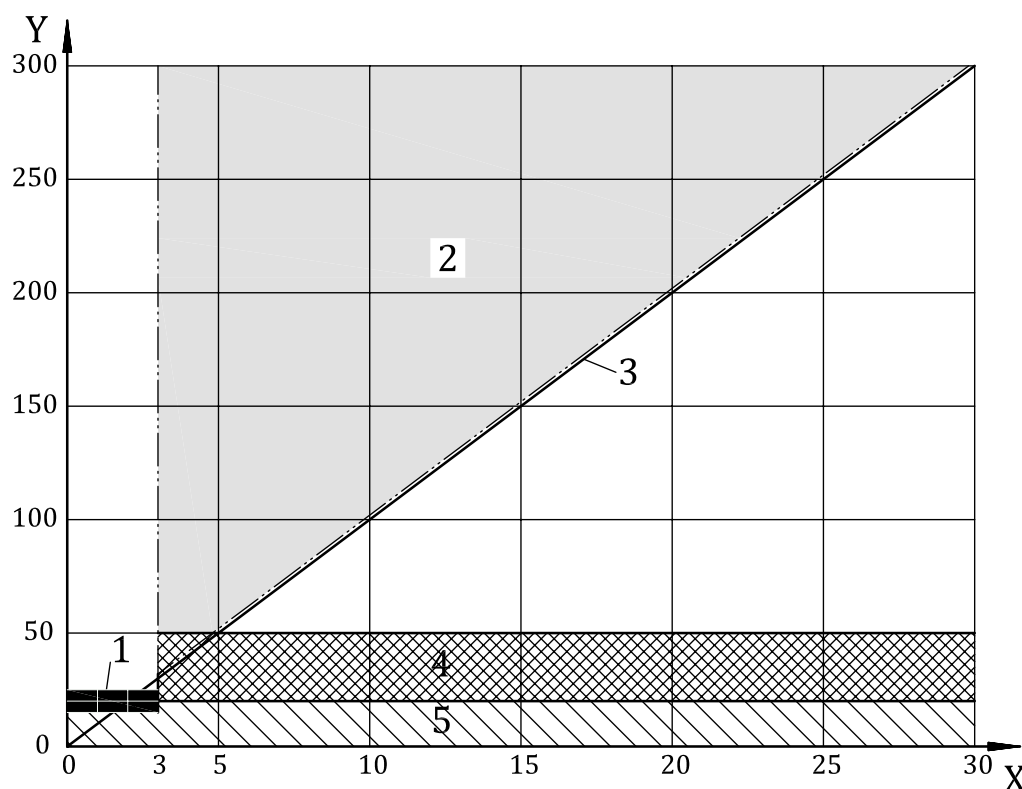

Key

- X thickness (a) [mm]
- Y width (b) [mm]
- 1 $b = 20 \pm 5$ if $a < 3$ [see 7.3 b) 1)]
- 2 $b \geq 10 \times a$ and $a > 3$ [see Annex B]
- 3 plane strain condition $b \geq 10 \times a$
- 4 $20 < b < 50$ if $a \geq 3$ [see 7.3 b) 2)]
- 5 $b \leq 20$ [see 7.3 a)]

Figure B.1 — Combinations of thickness (a) and width (b) in relation to plane strain condition, for test pieces given in 7.3

A bend test suitable for all applications and dimensions of a product should test the product in the most extreme state. The most extreme state of bending occurs when a plane strain condition is achieved. To

attain plane strain conditions, a test piece width-to-thickness ratio (b / a) ≥ 10 should be employed. This critical state (plane strain) is not reached if the width of the test piece is too small^{[1]to[5]}.

The specifications given in this annex can however lead to the following effects:

- reduced angles of approved bend, α , in comparison with test piece widths specified before in [7.3](#);
- as a consequence, test pieces can fail;
- increase of the testing force;
- increase of the weight of the test piece;
- the bendability requirements in product standards may not be fulfilled.

Nevertheless, the results of tests performed according to this annex are more realistic for several applications.

However, a test piece with a round or hexagonal cross-section (bar) is not an issue, since the most critical state (plane strain) is never attained.

B.2 General

Bendability of a sheet or a plate (rectangular shaped test piece) depends greatly on the width of the test piece. Different test piece widths promote different strain states. Bend tests performed on a too short test piece width can promote a non-conservative result (higher ductility, i.e. less tendencies for failures). In [Figure B.2](#) below, this is very clearly indicated. The same former diameter has been used but the bend results are very different depending on the width of the test piece used. The test piece to the left has a width, b , of 4 times the thickness, a . A too short width, b , in relation to the thickness, a , never attains the critical level of the triaxiality factor ($\eta[\bar{\theta}=0]=+1/\sqrt{3}\approx 0,58$) representing plane strain condition (in tension)^[6]. This value is obtained by the relation between triaxiality factor, η , and the Lode angle parameter, $\bar{\theta}$ ^{[7]to[9]} [see [Formula \(B.1\)](#)] calculating the roots setting the Lode angle parameter to $\bar{\theta} = 0$, i.e. representing plane strain path.

$$\cos\left[\frac{\pi}{2}(1-\bar{\theta})\right]=-\frac{27}{2}\eta\left(\eta^2-\frac{1}{3}\right) \quad (\text{B.1})$$

In [Figure B.2](#) approximate values of the triaxiality factor are shown (based on finite element simulations), confirming a good correlation between areas exposing failures and reaching triaxiality factor above the limit for plane strain.

NOTE The lode parameter and triaxiality factor are used for information about the mechanical background of plane strain condition, but they are not directly used in the test. The plane strain conditions are achieved if the specifications of [B.3](#) are used.

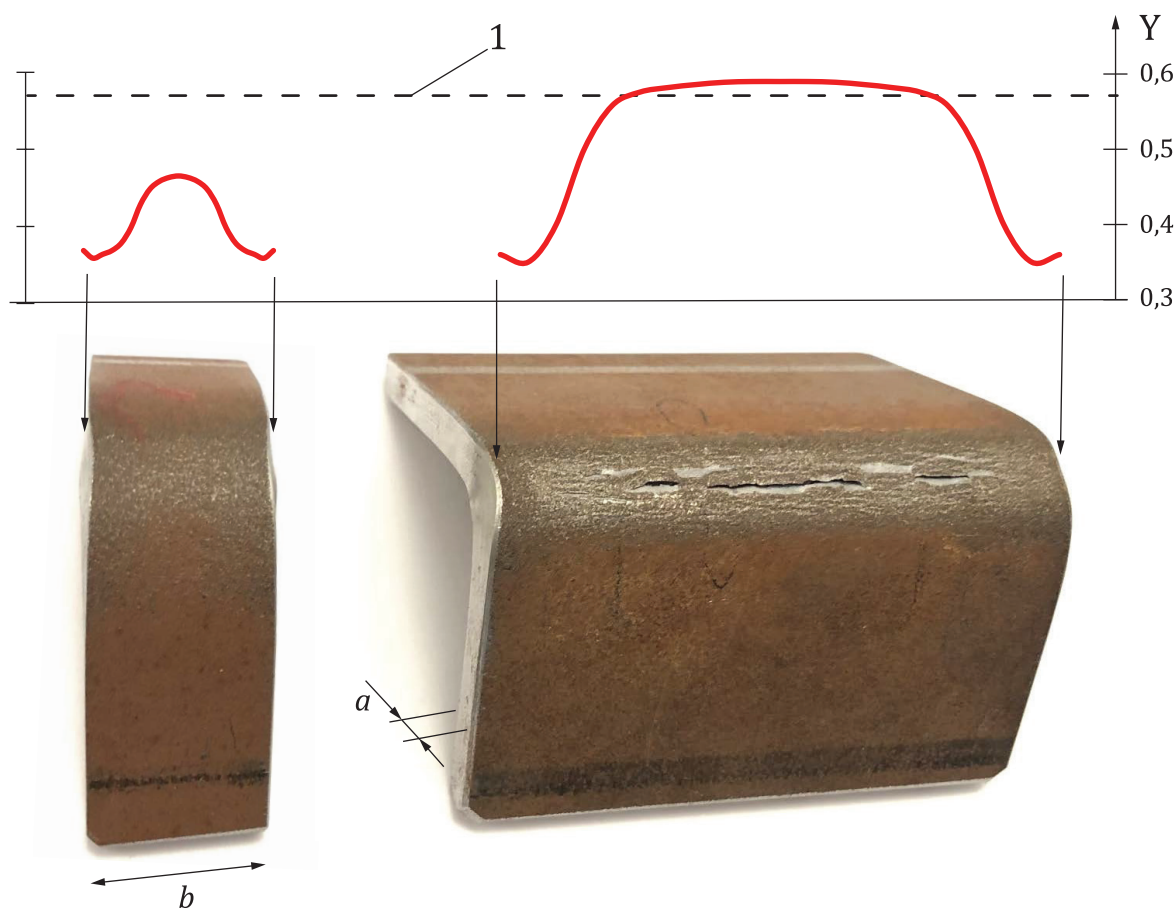

Key

Y triaxiality factor

1 critical value for plane strain condition

Figure B.2 — Differences in bendability depending on width (b)

B.3 Test piece

To attain plane strain conditions, a test piece width-to-thickness ratio (b / a) ≥ 10 shall be used.

This requirement is however already fulfilled for some thinner test pieces in 7.3, as shown in [Figure B.1](#).

B.4 Assessment

For rectangular test pieces, cracks can originate from the edge, as a result of poor edge preparation. These edge cracks are not an indication that the test piece failed the bend test as defined in 9.1. Therefore, cracks originating from the edge and extending no more than two thicknesses from the edge shall not be included in the test interpretation of 9.1. However, if the cracks originating from the edge extend more than two times the thickness into the width, then that test piece shall be considered invalid.

NOTE For a test piece width of about 10 times the thickness, the plane strain region corresponds to about the centre 60 % of the total width. Since plane strain bending assessment is desired, crack assessment is only considered in this region, and cracks occurring from the edges that do not extend into this area are not taken into consideration for the interpretation of the test results.

B.5 Test report

In addition to the information required in [Clause 10](#) a) to f), the report shall also contain information about the dimensions of the test piece used. Furthermore, a reference to this annex shall be included.

EXAMPLE ISO 7438:2020, Annex B.

Bibliography

- [1] HILL R. “*The Mathematical Theory of Plasticity*”. Clarendon Press, Oxford, (1950)
- [2] CRAFOORD R., “Plastic sheet bending”, Ph.D. Thesis, Chalmers Tekniska Högskola, Göteborg, (1970)
- [3] DUNCAN J. L. “*The Mechanics of Sheet Metal Forming,*” Edward Arnold Ltd., London, (1992)
- [4] CHAN W.M., CHEW H.P., LEE B.T.“, Finite element analysis of spring-back of V-bending sheet metal forming processes”, *Int. Journal of Materials Processing Technology*, **148**, 15–24, (2004)
- [5] CHEONG K. et al. “, Evaluation of the VDA 238-100 Tight Radius Bending Test using Digital Image Correlation Strain Measurement”, *Int. Journal of Physics, Conf. Ser.* **896** 012075, (2017)
- [6] LI Y., WIERZBICKI T.“, Prediction of plane strain fracture of AHSS sheets with post-initiation softening”, *Int. Journal of Solids and Structures* **47**, 2316–2327, (2010)
- [7] BAI Y., WIERZBICKI T.“, A new model of metal plasticity and fracture with pressure and Lode dependence”, *Int. Journal of Plasticity* **24**, 1071–1096, (2008)
- [8] WIERZBICKI T., XUE L. “On the Effect of the Third Invariant of the Stress Deviator on Ductile Fracture”. *Technical Report*”, Impact and Crashworthiness Laboratory, Massachusetts Institute of Technology, Cambridge, MA. (2005)
- [9] BAI Y., WIERZBICKI T.“, Application of extended Mohr-Coulomb criterion on ductile fracture”, *Int. Journal of Fracture* **161**, 1-20 (2010)

Bureau of Indian Standards

BIS is a statutory institution established under the *Bureau of Indian Standards Act, 2016* to promote harmonious development of the activities of standardization, marking and quality certification of goods and attending to connected matters in the country.

Copyright

BIS has the copyright of all its publications. No part of these publications may be reproduced in any form without the prior permission in writing of BIS. This does not preclude the free use, in the course of implementing the standard, of necessary details, such as symbols and sizes, type or grade designations. Enquiries relating to copyright be addressed to the Head (Publication & Sales), BIS.

Review of Indian Standards

Amendments are issued to standards as the need arises on the basis of comments. Standards are also reviewed periodically; a standard along with amendments is reaffirmed when such review indicates that no changes are needed; if the review indicates that changes are needed, it is taken up for revision. Users of Indian Standards should ascertain that they are in possession of the latest amendments or edition by referring to the website-www.bis.gov.in or www.standardsbis.in.

This Indian Standard has been developed from Doc No.: MTD 03 (21425).

Amendments Issued Since Publication

Amend No.	Date of Issue	Text Affected

BUREAU OF INDIAN STANDARDS

Headquarters:

Manak Bhavan, 9 Bahadur Shah Zafar Marg, New Delhi 110002
Telephones: 2323 0131, 2323 3375, 2323 9402

Website: www.bis.gov.in

Regional Offices:

	Telephones
Central : 601/A, Konnectus Tower -1, 6 th Floor, DMRC Building, Bhavbhuti Marg, New Delhi 110002	{ 2323 7617
Eastern : 8 th Floor, Plot No 7/7 & 7/8, CP Block, Sector V, Salt Lake, Kolkata, West Bengal 700091	{ 2367 0012 2320 9474
Northern : Plot No. 4-A, Sector 27-B, Madhya Marg, Chandigarh 160019	{ 265 9930
Southern : C.I.T. Campus, IV Cross Road, Taramani, Chennai 600113	{ 2254 1442 2254 1216
Western : Plot No. E-9, Road No.-8, MIDC, Andheri (East), Mumbai 400093	{ 2821 8093

Branches : AHMEDABAD. BENGALURU. BHOPAL. BHUBANESHWAR. CHANDIGARH. CHENNAI. COIMBATORE. DEHRADUN. DELHI. FARIDABAD. GHAZIABAD. GUWAHATI. HIMACHAL PRADESH. HUBLI. HYDERABAD. JAIPUR. JAMMU & KASHMIR. JAMSHEDPUR. KOCHI. KOLKATA. LUCKNOW. MADURAI. MUMBAI. NAGPUR. NOIDA. PANIPAT. PATNA. PUNE. RAIPUR. RAJKOT. SURAT. VISAKHAPATNAM.