सार्वजनिक तरणताल — सुरक्षा संहिता

Swimming Pool for Public —
Code of Safety

ICS 97.220.10

© BIS 2017



भारतीय मानक ब्यूरो
BUREAU OF INDIAN STANDARDS
मानक भवन, 9 बहादुरशाह ज़फर मार्ग, नई दिल्ली-110002
MANAK BHAVAN, 9 BAHADUR SHAH ZAFAR MARG
NEW DELHI-110002
www.bis.org.in www.standardsbis.in

FOREWORD

This Indian Standard was adopted by the Bureau of Indian Standards, after the draft finalized by the Occupational Health and Safety and Chemical Hazards Sectional Committee had been approved by the Chemical Division Council.

Number of accidents happen due to non availability of appropriate safety arrangements as well as poor quality of maintenance and operation of swimming pools. Provisions for safety parameters like water quality, availability of competent swimming coach/qualified instructor, life buoy, life jacket, artificial resuscitator, oxygen cylinder, provision of showers, first-aid box, medical attendant, telephone facility; lighting arrangements, etc, are to be considered right from the design stage so as to provide safe and quality service to the customers. Further, in India most of the cities are facing acute water shortages. Swimming pool thus needs to be designed taking into consideration recirculation of water with proper disinfection as well as various safety factors so as to conserve water.

The objective of this standard is to provide recommended minimum guidelines for the design, operation and maintenance of the swimming pool. It is also intended to assist the regulatory bodies in the implementation of public swimming pool criteria for safe operation.

There is no ISO standard on this subject. In the formulation of this standard, assistance has been taken from the following publications:

- a) ANSI/NSPI-1-1991 Standard for public swimming pool
- b) Public Health Chapter I: Department of Public Health Subchapter N: Recreational Facilities Part 820 Illinois Swimming Pool and Bathing Beach Code
- c) *The Greater Mumbai Swimming Pools (Licensing and Controlling) Rules, 1972*

Indian Standard

SWIMMING POOL FOR PUBLIC — CODE OF SAFETY

1 SCOPE

1.1 This standard prescribes the code of safe practices for aspects of design, operation and maintenance of public swimming pool, keeping in view general and specific safety requirements.

1.2 This Code is not intended to contravene the provision of any of the existing Government regulations. It is the responsibility of the user of this Code to establish appropriate safety and health practices and comply with regulatory and statutory requirements.

1.3 This Code does not address residential and above ground swimming pools.

2 REFERENCES

The standards listed below contain provisions which through reference in this text constitute provisions of this standard. At the time of publication, the editions indicated were valid. All standards are subject to revision and parties to agreements based on this standard are encouraged to investigate the possibility of applying the most recent editions of the standards indicated below:

<i>IS No.</i>	<i>Title</i>
3328 : 1993	Quality tolerances for water for swimming pools (<i>first revision</i>)
6494 : 1988	Code of practice for water-proofing of underground water reservoirs and swimming pools

3 TERMINOLOGY

For the purpose of this standard the following definitions shall apply.

3.1 Appurtenance — An accessory facility or feature at a swimming pool, such as a diving board, slide, wading pool, plunge pool, spray pool.

3.2 Bather Load — The maximum number of persons that may be allowed in the pool area at one time without creating undue health or safety hazards.

3.3 Deep Area — An area of a swimming pool in which the water depth exceeds five feet.

3.4 Diving Pool — A pool designed and intended for use exclusively for diving.

3.5 Drop Slide — A slide with an exit angle exceeding 11° measured downward from the horizontal.

3.6 Inlet — An opening or fitting through which filtered water enters the pool.

3.7 Main Drain — The outlet or outlets in the floor of the pool.

3.8 Make-up Water — The water added to a pool to replace that which is lost.

3.9 Manager/Operator — The person or entity responsible for the actual daily operation, or for the supervision of the operation, of a swimming pool or bathing beach.

3.10 Pool — A swimming pool or other recreational water basin utilized in conjunction with or as an appurtenance to a swimming pool.

NOTE — The term does not refer to spas and therapy pools not designed or intended for swimming or to basins for individual use that are drained after each use.

3.11 Pool Depth — The vertical distance between the pool floor and the water level.

3.12 Qualified Life Guard — A qualified and trained person, stationed at the top of a water slide and responsible for ensuring safe use of the slide.

3.13 Shallow Area — An area in a swimming pool, in which the water depth does not exceed 1.5 m at any point.

3.14 Skimmer — A mechanical device connected to the recirculation piping which is used to skim the pool surface.

3.15 Transition Point — A location in a shallow area of a swimming pool where an area, having a floor slope of no more than 30 cm vertical in 3.65 m horizontal, adjoins an area where the floor slope exceeds one in 12.

3.16 Turnover Period — The time required to recirculate a volume of water equivalent to the water volume of the pool through the filtration system.

3.17 Wading Pool — A pool having a water depth not exceeding 76 cm.

3.18 Water Level — The level of the overflow lip of a perimeter overflow system or the mid-level of surge weirs, if present, or the mid-level of the skimmer operating range.

3.19 Zero-Depth Edge — That portion of the perimeter of a zero-depth pool where the pool floor

intersects the pool water surface.

3.20 Zero-Depth Pool — A swimming pool where the pool floor intersects the water surface along a portion of its perimeter.

4 DESIGN

4.1 Structure

The pool should be so designed to withstand all anticipated hydraulic structural loadings for both full and empty conditions. All appurtenances to the pool, such as diving boards and slides, shall be designed to carry the anticipated load. Any obstruction creating a safety hazard shall not extend into or above the pool, or shall not protrude from the floor of the pool. All appurtenances like diving boards, ladders, handrails, slides, etc. should not have any sharp edges or surfaces. Decks and walkways should not have any projections from the floor. Designers may refer IS 6494 for providing the guidance on the procedures and the precautions to be taken during construction of swimming pool to ensure the water tightness of the structure.

4.2 Material

Any suitable materials that are non-toxic and provide a rigid watertight shell with a smooth, impervious, light coloured finish should be used to construct the pool. The floor of shallow areas shall have a slip-resistant finish. Sand or earth shall not be permitted to be used as an interior finish in a swimming pool.

4.3 Dimensions

The shape and size of a pool largely depend on the usage. Shape should be considered from the standpoint of safety and circulation of the pool water.

NOTES

1 A long and rectangular pool may be ideal for sports and

exercise as it gives length and breadth, but the shape of a pool for recreation largely depend on the choice of the owners, available space for making the pool and the design of the house.

2 In sports normally the swimming pool are 50 m long, minimum 21 m wide and 1.8 m overall depth.

4.4 Floor Slopes

Slope of the floor of the pool should be made downward toward the main drain. All slopes should be uniform. The slope in shallow areas should not exceed 30 cm vertical in 3.6 m horizontal except for a slope directed downward from a transition point, which shall not exceed 30 cm vertical in 1m horizontal. In portions of the pool with a depth greater than 1.5 m, the front slope of the deep area shall not be steeper than 30 cm in 1 m. The slope requirements are shown in Fig. 1.

4.5 Transition Point

Transition points should be marked with a stripe on the pool floor having a width of at least 10 cm and a colour that contrasts with that of the floor, and with a buoyed safety rope with coloured buoys, installed at least 30 cm on the shallow side of the transition point. In pools having adjoining shallow and deep areas, a safety rope with colored buoys shall be installed where the water depth reaches 1.5 m.

4.6 Pool Walls

4.6.1 Where the pool depth is 1 m or less, pool walls shall be vertical to the floor and the junction of the wall with the floor shall consist of a cove with a radius not exceeding 15 cm. Where the pool depth exceeds 1 m, pool walls shall meet one of the following criteria:

- a) The wall shall be vertical for a distance of at least 1.5 m below the water level, below which the wall may angle to the floor; or
- b) The wall shall be vertical for a distance of at least 1 m below the water level, below which

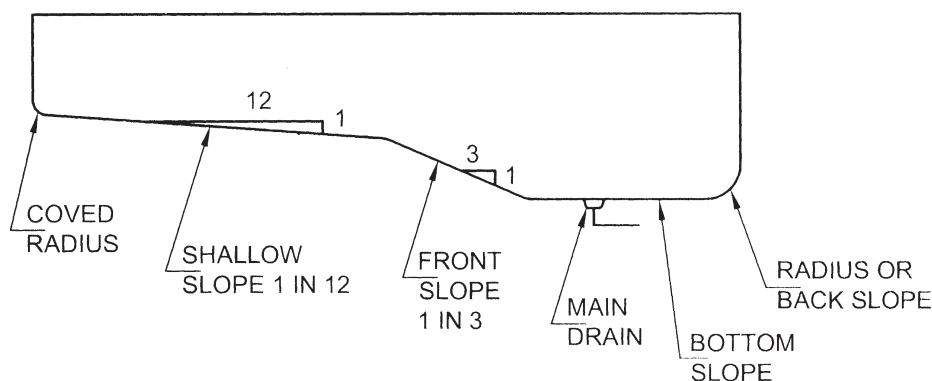

All dimensions in metre.

FIG. 1 SLOPE OF POOL FLOOR

the wall shall form a curve to the floor. The curve shall be tangent to the pool wall and shall have a radius of curvature at least equal to the vertical distance between the centre of curvature and the pool floor.

4.6.2 All junctions between pool walls, and between pool walls and the pool floor, shall be covered with a minimum radius of 25 mm.

4.7 Water Depth

Water depth at the shallow end of the swimming pool should be around 1 m. The beginner's area of the pool shall be visually set apart from, but may be adjoined to the shallow area and shall not adjoin to the deep area.

4.8 Walkways and Deck Areas

4.8.1 Pools shall be completely surrounded by a deck that is at least 1.2 m in width and extends completely around and adjacent to the pool. There shall be no obstructions or interruptions of the pool deck within the 1.2 m adjacent to the pool other than necessary structural supports, or appurtenances such as diving boards, slides, perimeter overflow systems, or handrails. A clear, unobstructed walkway at least 1.1 m in width shall be maintained at such obstructions or interruptions.

4.8.2 Structural supports located within the minimum required deck width or within 1.2 m of the swimming pool shall be no closer than 3 m apart measured parallel to the adjacent perimeter of the pool, with the dimension of any single support in a plane parallel to the adjacent pool perimeter not greater than 1 m and the sum of all such support dimensions no greater than 10 percent of the pool perimeter.

4.8.3 The deck between two adjacent swimming pools shall be at least 2.5 m wide. All decks and walkways shall have an unobstructed overhead clearance of at least 2 m.

4.8.4 Synthetic material which meets the following criteria may be installed for deck coverings:

- a) Non-fibrous that allows drainage such that it will not remain wet or retain moisture;
- b) Inert and will not support bacterial or fungal growth;
- c) Durable;
- d) Cleanable; and
- e) Provides a slip-resistant finish.

4.8.5 The decks and walkways shall have a paved surface. The surface of the pool deck, and other surfaces used for foot contact, such as gratings of perimeter overflow systems, shall be slip-resistant.

4.8.6 The outer perimeter of the deck for outdoor pools shall be at least 10 cm higher than the surrounding ground surface except where access is provided to adjacent turf areas.

4.9 Ladders, Step-Holes, Steps and Ramps

4.9.1 Swimming pool shall have at least two means of egress, located near opposite ends. A means of egress shall consist of a ladder, step-holes and grab rails, stair, ramp, or zero-depth edge. Pools of 9 m or more in width shall have at least four means of egress that shall be located near each end and on opposite sides. The distance from any point with a depth greater than 76 cm in the swimming pool to a means of egress shall not exceed 15 m. At least two ladders or sets of step-holes shall be located at the deep area of the swimming pool when more than one diving board is provided.

4.9.2 Step-holes shall have a minimum tread depth of 12 cm. Where step-holes or ladders are provided, there shall be a handrail or grabrail at the top on both sides which extends to the edge of the pool.

4.9.3 Steps shall be of contrasting color or marked to contrast from the pool floor and have uniform size treads of at least 30 cm and a rise of no more than 30 cm. Steps shall be located where the water depth is 1.4 m or less and shall have no pointed or sharp edges. One sturdy handrail or grabrail per 4 m of step width or fraction thereof, extending the length of the steps, shall be provided.

4.9.4 All ladders, step-holes, and steps shall have slip-resistant surfaces.

4.9.5 Slope of the ramp shall not be more than one in twelve. Ramp shall have a slip-resistant surface; handrails on both sides and its width shall not be more than 1.4 m.

4.10 Diving Area

4.10.1 The dimensions of the diving area of a pool that has diving boards or platforms of three m or less in height shall comply with dimensions given in Table 1 and shown in Fig. 2. In such pools, the distance from the plummet to the pool wall ahead shall be at least 11 m.

4.10.2 Swimming pools with diving facilities in excess of three meters in height shall comply with dimensions given in Table 2 and illustrated in Fig. 3. If the pool is used for swimming as well as diving then transition slope from the deep to the shallow end shall not be steeper than one in three.

4.10.3 There shall be no obstruction extending from the wall or the floor into the clear area of the diving portion of the pool. There shall be an unobstructed

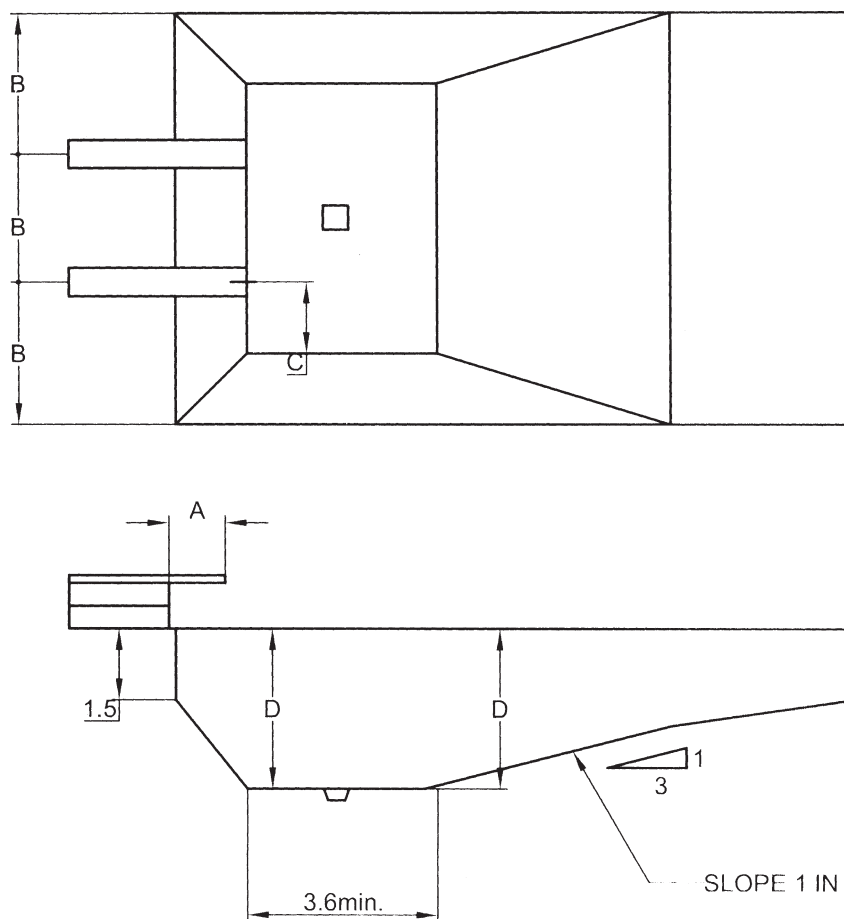

All dimensions in metre.

FIG. 2 GENERAL POOL WITH DIVING AREA DIMENSIONS

Table 1 Dimensions of Swimming Pools with Diving Facilities of 3 m or Less in Height
(Clause 4.10.1)

Sl No.	Minimum distance indicated	Minimum distance indicated		
		≤ 0.5 m Platform, Min	1 m Platform, Min	3 m Platform, Min
(1)	(2)	(3)	(4)	(5)
i)	A — End wall to Tip of Board	1	1.5	1.5
ii)	B — Centre of board to sidewall or adjacent board	3	3	3.6
iii)	C — Centre of board laterally to point of required depth	1.2	1.2	1.8
iv)	D — Depth at end of board and for beyond 3.6 m	2.8	3	3.6

distance of 5 m above the diving board measured from the center of the front end of the board, and this clearance shall extend at least 2.5 m behind, 2.5 m to each side, and 5 m ahead of the measuring point.

4.10.4 Handrails shall be provided at all steps and ladders leading to diving boards. Platforms and diving boards which are 1 m or higher shall be protected with guard railings. One meter diving board guard rails shall

be at least 76 cm above the diving board and extend to the pool water's edge. All platforms or diving boards higher than one meter shall have guard rails which are at least 76 cm above the diving board or platform and extend to the pool water's edge. Three meter platforms and boards shall have a side rail barrier.

4.11 Starting Platforms

Starting platforms may be from 0.50 m to 0.75 m above

Table 2 Dimensions of Swimming Pools with Diving Facilities in Excess of 3 m in Height
(Clause 4.10.2)

Sl No.	Dimensions	Designation	5 m Platform, Min m	7.5 m Platform, Min m	10m Platform, Min m
(1)	(2)	(3)	(4)	(5)	(6)
i)	Length		6.0	6.0	6.0
ii)	Width		1.5	1.5	1.5
iii)	From plummet: back to pool wall	<i>A</i>	1.5	1.5	1.8
iv)	Back to platform directly below		—	1.5	1.5
v)	From plummet to pool wall at side	<i>B</i>	3.9	4.5	5.2
vi)	From plummet to adjacent plummet	<i>C</i>	—	—	3.6
vii)	From plummet to pool wall ahead	<i>D</i>	10.5	11.0	13.7
viii)	On plummet from board to ceiling overhead	<i>E</i>	3.6	3.6	3.6
ix)	Clear overhead behind and each side plummet	<i>F</i>	2.7	3.0	5.0
x)	Clear overhead ahead of plummet	<i>G</i>	5.0	5.0	5.0
xi)	Depth of water at plummet	<i>H</i>	4.3	4.5	5.2
xii)	Bottom distance ahead of plummet	<i>J</i>	6.0	8.0	12.2
xiii)	Bottom depth ahead of plummet	<i>K</i>	3.3	4.0	4.5
xiv)	Bottom distance each side of plummet	<i>L</i>	3.6	4.0	4.3
xv)	Bottom depth each side of Plummet	<i>M</i>	4.3	4.5	5.2

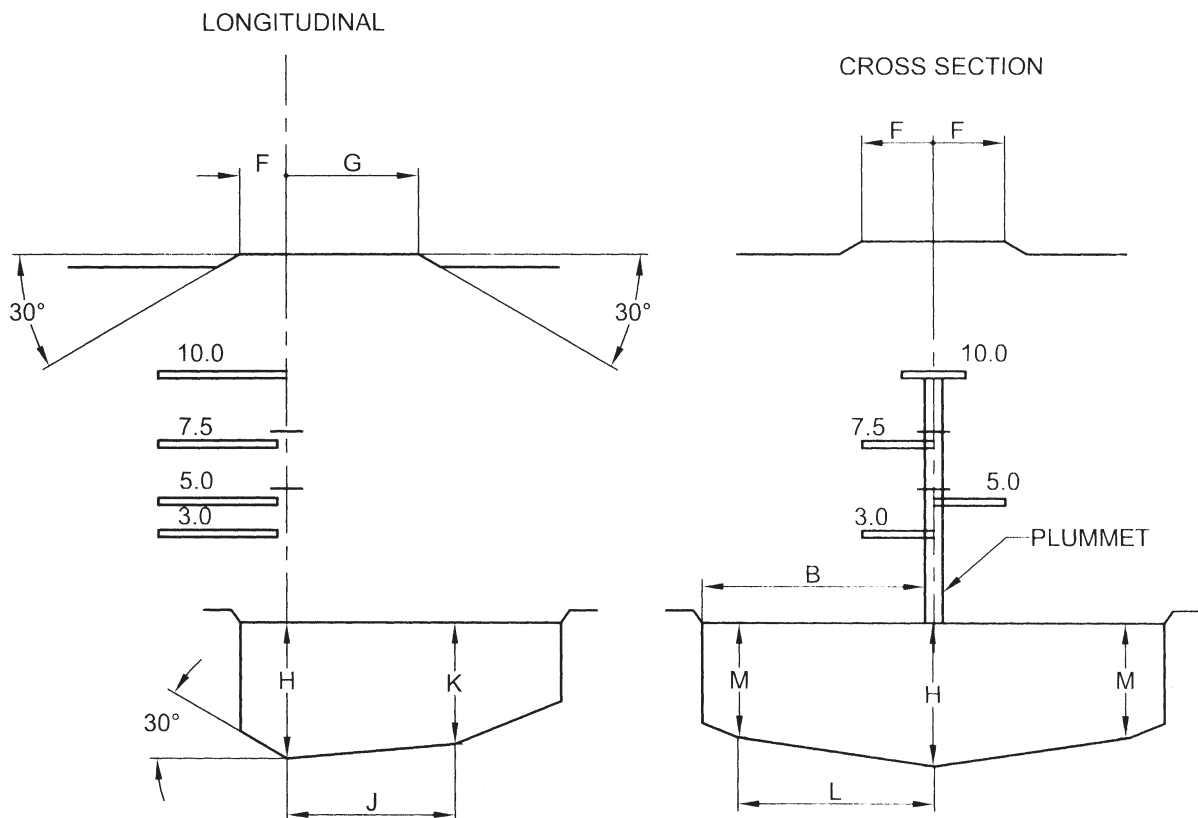

FIG. 3 POOL WITH DIVING FACILITIES IN ACCESS OF THREE METERS IN HEIGHT

the surface of water. The maximum height of the platform above the water shall be 0.75 m where the water depth is 1.2 m or greater and 0.50 m when the water depth is less than 1.2 m. The surface area of each platform shall be 0.5 m × 0.5 m with a maximum slope of not more than 10°. Surface of each block shall be covered with non-slip material and with back stroke hand grip facility.

4.12 Electrical Installation – Lighting

4.12.1 Artificial lighting shall be provided at all indoor pools and at all outdoor pools that are open for use after sunset in accordance with one of the following:

- a) Underwater lighting of at least 8.35 lumens or 5.5 W/m² of pool water surface area with 12V SELV supply and located to provide illumination of the entire pool floor; plus area lighting of at least 10 lumens or 6.6 W/m² of deck area.
- b) If underwater lights are not provided, at least 33.5 lumens or 2.2 W/m² of pool water surface area and deck area.

4.12.2 Where portable electric vacuum cleaning equipment is used, electrical receptacles with ground-fault circuit interrupter protection shall be provided. Separation between receptacles shall be a maximum of 30 m. All receptacles installed in the swimming pool area shall have waterproof covers and ground-fault circuit interrupter protection.

4.12.3 Lighting controls should not be accessible to the public.

4.12.4 All conductive parts like railings, grab rails, handrails, metal parts of electrical equipment of pool water circulation system, etc., should be connected to system earth. Electrical wiring should follow the stipulated regulations which requires the use of SELV systems.

4.13 Ventilation

Adequate ventilation shall be provided in facilities to prevent objectionable odor.

4.14 Shower and Bathroom

Separate shower, dressing booth and sanitary facilities shall be provided for each gender. This may not be applicable for schools and other institutional use where a pool may be open to one gender at a time. The rooms should be well lit, drained, ventilated, and of good construction, using impervious materials. They should be developed and planned to ensure maintenance of good sanitation throughout the building at all times. Floors should have a slip-resistant surface and sufficiently smooth to ensure ease in cleaning. All light

fittings in the shower and bathrooms to be doubly insulated and should be completely enclosed. Socket outlets in bathrooms or change rooms, if any, to be either supplied individually by an isolating transformer or by SELV transformer or protected by ELCBs.

5 SWIMMING POOL WATER TREATMENT SYSTEM

5.1 General

A water treatment system shall be provided to filter, chemically balance and disinfect the swimming pool water. The system shall be so designed for the recirculation flow rate that turnover period shall not exceed 8 h in case of diving pool, 2 h for wading pool, and 6 h for other pools.

5.2 Hair and Lint Strainer

A hair and lint strainer shall be installed on the suction side of the pump except on vacuum filter systems. The strainer basket shall be easily removable. Valves shall be installed to allow the flow to be shut off during cleaning, switching baskets, or inspection.

5.3 Inlets

Inlets for filtered water shall be located and directed suitably to produce uniform circulation of water to facilitate the maintenance of a uniform disinfectant residual throughout the entire pool without the existence of dead spots, and to produce surface flow patterns that effectively assist skimming.

5.4 Outlets

Pools shall be provided with a main drain at the deepest point. The main drain shall be connected to the recirculation system. Openings must be covered by grating which cannot be removed without the use of tools. Openings of the grating shall be at least four times the area of the main drain pipe or have an open area. The maximum width of grate openings shall be 3.5 cm. Main drains and all other suction outlets installed in the pool shall be designed to prevent bather entrapment.

5.5 Make-up Water

Make-up water shall be added through a fixed air gap of at least 15 cm to the pool, surge tank, vacuum filter tank, or other receptacle. When make-up water is added directly to the pool, the fill-spout should be located under a low diving board or immediately adjacent to a ladder rail, grab rail, or fixed lifeguard chair.

5.6 Filtration

The design filtration rate in the particular application in which the filter is utilized shall not exceed the

maximum design filtration rate for which the filter was installed.

Wash or backwash water from diatomaceous earth filters shall be passed through a separation tank designed for removal of suspended diatomaceous earth and solids, prior to disposal.

5.7 Disinfection

The pool water shall be continuously disinfected by suitable disinfecting agent that imparts easily measured residual. Gaseous chlorine, chlorine compounds, bromine compounds or other bactericidal agents should be used to maintain the quality parameters of water as specified in 8.

6 PERSONNEL

6.1 Pool Manager

A person who shall be held responsible for the operation of the swimming pool facility in accordance with the consent letter shall be designated as pool manager/operator.

6.2 Swimming Coach/Instructor and Life Guard

Competent swimming coach/instructor shall be provided at all swimming pools who has adequate knowledge of first aid and artificial respiration. In addition lifeguard should be provided when persons under the age of 16 are allowed in the pool enclosure without supervision by a parent, guardian or other responsible person at least 16 years of age. All areas of the pool must be visible to a lifeguard. Lifeguard, if any, shall be dressed in swimming attire and be identified as a lifeguard. A trained lifeguard (with first aid training) should be available at the poolside, during the hours of operation and as and when people are swimming or playing in water.

7 SPECIFIC SAFETY FEATURES

7.1 Rescue Equipment

7.1.1 At least one ring buoy or similar floating device shall be kept ready with an attached throw rope with a length at least equal to the maximum width of the swimming pool or 15 m, whichever is less.

7.1.2 A light strong pole not less than 3.6 m long, including a body hook.

7.2 First Aid Kit

7.2.1 A swimming pool facility shall have a first-aid kit which contains at least the following:

- a) Band-Aids.
- b) Sterile 100 × 100 mm bandage compress.
- c) Self-adhering gauze bandage.

- d) Disposable gloves.
- e) Chemical cold compress.

7.2.2 The first-aid kit shall be prominently mounted in the swimming pool enclosure, or a sign stating its location shall be posted near the swimming pool. The first-aid kit shall be accessible when the swimming pool is open. Items which have a shelf life shall be kept current.

7.2.3 Emergency Telephone and Emergency Contact List

A telephone shall be accessible in the vicinity of the swimming pool, in or within 90 m of the pool enclosure. The telephone numbers of the local police, state police, fire department, physician, ambulance service, and a hospital, shall be posted in a conspicuous place near the telephone. The location of the emergency telephone shall be posted in the swimming pool area unless the telephone is located in the pool area.

7.3 Depth Markers

7.3.1 The depth of water shall be marked at or above the water surface on the wall of the pool and on the edge of the deck next to the pool so as to be readable by persons entering or in the pool. Depth markings shall be provided at the shallow and deep ends of the pool, the transition point, and the point of maximum depth, and shall be spaced at not more than 7.5 m intervals measured peripherally, except that depth markings are not required at a zero-depth edge.

7.3.2 Depth markers shall indicate pool depth in metric system, and shall be of a colour that contrasts with the background. Numerals indicating depth shall be a minimum of 10 cm high.

7.3.3 In shallow areas, 'no diving' markers or symbols at least 10 cm high must be located at not more than 7.5 m intervals around the pool perimeter except at a zero-depth edge.

8 WATER QUALITY

8.1 Disinfectant Residual

8.1.1 Where chlorine is used as a disinfectant, the chlorine residual shall be maintained between 1.0 and 4.0 ppm. as free chlorine residual. A free chlorine residual of at least 2.0 ppm. shall be maintained when the pool water temperature exceeds 30°C.

8.1.2 Where bromine is used as a disinfectant, a bromine residual shall be maintained between 2.0 and 8.0 ppm. as total bromine. A bromine residual of at least 4.0 ppm. shall be maintained when the pool water temperature exceeds 30°C.

8.1.3 Where chlorinated cyanurates are used, the

cyanuric acid concentration shall not exceed 100 ppm.

8.1.4 Where silver/copper or copper ion generators are used, the concentration of copper shall not exceed 1.3 ppm. and the concentration of silver shall not exceed 0.05 ppm.

8.1.5 Where ozone is used, the ambient air ozone concentration shall be less than 0.1 ppm. at all times either in the vicinity of the ozonator or at the pool water surface.

8.2 For all other physical, chemical and bacteriological parameters the quality of water used in swimming pools in continuous circulation type shall conform to IS 3328.

9 OPERATION AND MAINTENANCE

9.1 Pool and Pool Area

9.1.1 The swimming pool shall be maintained free from sediment, lint, dirt and hair. The walls, ceilings, floors, equipment and the pool area shall be properly maintained so that they are protected from deterioration. Cracks and other defects in the pool, if appear, should be repaired. All equipment shall be maintained in proper condition, with all required components in place.

9.1.2 Pool decks should be rinsed daily. Indoor pool decks shall be disinfected at least weekly. No furniture, plants or other furnishings shall be placed within 1.2 m of the pool. This area should be kept free of obstructions such as chairs and baby strollers and maintenance equipment.

9.1.3 Floats or tubes not in use should be removed from the pool. Safety ropes shall be kept in place except when the swimming pool is being used exclusively for lap swimming or competition.

9.1.4 Starting Platforms

Starting blocks shall not be used for any other purpose than competitive swimming activities. Starting blocks should be securely anchored when in use but removed or prohibited from use when not being used in conjunction with competitive swimming or training.

9.1.5 A register should be maintained at the pool, recording the user details. The user should sign before using the pool.

9.1.6 Lockers, with locking arrangement (preferably number locks) to be provided to the users to keep their belongings and valuables.

9.1.7 Notice boards (one at the entrance and one near the pool) should be put up declaring:

- a) The hours of operation of the pool.
- b) The users shall take a shower before entering the pool.

- c) The users should be appropriately dressed.
- d) Usage of the pool is at users risk only.
- e) Persons under the influence of alcohol/drugs are not allowed to use the pool.
- f) Children under 12 years of age will be permitted only, if accompanied by adults.
- g) Persons not knowing swimming are not allowed to use the pool independently.

9.1.8 Usage of swimming pools should be barred during thunderstorms.

9.2 Perimeter Overflow and Skimmers

The perimeter overflow systems or automatic surface skimmers should be kept clean and free of leaves or other debris which would restrict flow. The strainer baskets for skimmers should be cleaned daily. The flow through each skimmer shall be adjusted as often as necessary to maintain a vigorous skimming action which will remove all floating matter from the surface of the water. The pool water should be maintained at an elevation such that effective surface skimming is accomplished. For pools with perimeter overflow systems, adequate surge storage capacity should be maintained so that flooding of the perimeter overflow system does not occur during periods of peak usage.

9.3 Inlet Fittings

Inlets should be checked frequently so that the rate of flow through each inlet establishes a uniform distribution pattern. Inlets in pools with surface skimmers shall be adjusted as necessary to provide vigorous skimming.

9.4 Security

Doors or gates in the swimming pool enclosure shall be kept closed and locked when the swimming pool is closed.

9.5 Bather Loads

The number of persons within a swimming pool enclosure should not exceed the permissible bather load as specified in the consent letter. The bather load shall be posted at the pool entrance or at a location where it can be seen by all patrons and shall be enforced by the manager/operator.

9.6 Electrical Systems

Electrical system shall be maintained in accordance with the National Electrical Code. Wiring Regulations, if any should also be maintained. Electrical wiring shall follow the stipulated regulations.

9.7 Diving Equipment

Diving equipment for swimming pool with diving

facility shall be maintained in a safe condition, be securely anchored, and have a slip-resistant surface.

9.8 Operation of Mechanical Equipment

9.8.1 Manufacturers' instructions for operation and maintenance of mechanical and electrical equipment, as well as pump performance curves, shall be kept available at the pool. All valves and piping in the equipment room must be permanently identified as to use and direction of flow. A valve operating procedure must be provided in the equipment room for each operation (for example, recirculation, filtration, backwashing, etc).

9.8.2 Recirculation pumps shall be kept in good repair and condition. The pump discharge or inlet supply line valve shall be adjusted as necessary to maintain the design flow rate.

9.8.3 Filtration Equipment

The filtration flow rate shall not exceed the maximum filtration design flow rate specified by the filter manufacturer for public swimming pool usage. Where this rate is not known or has not been determined, the flow rate shall not exceed 67 litre per minute per square foot of filter area for high-rate sand filters.

9.8.4 Hair and Lint Strainers

Hair and lint strainers shall be cleaned to prevent clogging of the suction line and cavitations. The pump shall be stopped before the strainer is opened to avoid drawing air into the pump and losing the prime.

9.8.5 Flowmeters

Flowmeters shall be maintained in an accurate operating condition and readable.

9.8.6 Vacuum and Pressure Gauges

The lines leading to the gauges shall be bled occasionally to prevent blockage.

9.8.7 Gas Chlorinators

9.8.7.1 The manager/operator shall post the telephone numbers of the appropriate emergency personnel to contact in the event of a chlorine gas emergency.

9.8.7.2 Area where gas chlorinators are stored should be kept locked at all times and only authorized personnel to be allowed into the storage area. Chlorine cylinders shall be stored indoors in the area designed for that purpose and away from a direct source of heat. They shall be chained or strapped to a rigid support to prevent accidental tipping. Cylinders shall not be moved unless the protection cap is secured over the valve. Gas mask, approved for use in a chlorine atmosphere, shall be kept outside the chlorine room in a locked PPE Box at all times. Only authorized personnel to be allowed

to use the mask. The gas mask canister shall be replaced regularly as per the manufacturer's recommendations.

9.8.7.3 Chlorinators, gas lines, injectors, vent lines and cylinders shall be checked daily for leaks. In case of a chlorine leak, corrective measures shall be undertaken only by trained persons wearing proper safety equipment. All other persons should be asked to leave the dangerous area until conditions are again safe.

9.8.8 Positive Displacement Feeders

9.8.8.1 Positive displacement feeders should be periodically inspected and serviced.

9.8.8.2 When a chemical feeder is used with calcium hypochlorite solution, to minimize sludge accumulation in the unit, the lowest practicable concentration of solution shall be used, and in no case shall this concentration exceed 5 percent. If liquid chlorine solution is used, the dilution with water is not critical to the operation of the unit. After first thoroughly rinsing with water, a small amount of mild acid solution may be fed through the unit periodically, to dissolve sludge accumulations.

9.8.9 pH Adjustment

9.8.9.1 Soda ash or caustic soda may be used to raise the pool water pH. Protective equipment and clothing, including rubber gloves and goggles, must be available for the handling and use of this chemical.

9.8.9.2 Sodium bisulphate, carbon dioxide gas or muriatic acid should be used to lower pool water pH. Carbon dioxide cylinders shall be securely chained or otherwise restrained in a manner that will prevent tipping. Protective equipment and clothing, including rubber gloves and goggles, must be available for handling this chemical.

9.8.10 Miscellaneous Chemicals

9.8.10.1 Chemicals shall be kept covered and stored in the original, labelled container, away from flammables and heat and in a clean, dry, well-ventilated place which prevents unauthorized access to the chemicals.

9.8.10.2 If polyphosphates are used for sequestering iron, the concentration of polyphosphates shall not exceed 10 p.p.m.

9.8.11 Acoustics

Suitable arrangement should be made to ensure that safety instructions can be heard, considering the noise level in peak hours.

9.8.12 Monitoring and Reporting

9.8.12.1 Operation reports

The pool manager/operator shall keep the daily record of swimming pool or other pool operational data.

9.8.12.2 *Water quality testing*

Disinfectant residual and pH tests shall be made on samples collected from the shallow and deep areas of each swimming pool, at least twice daily. Where chlorine is used as a disinfectant, testing for combined chlorine shall be performed at least weekly. In addition, where chlorinated cyanurates are utilized as a chlorine disinfectant, testing for cyanuric acid concentration shall be performed at least weekly. Where ozone is utilized, testing to determine the ozone concentration immediately above the pool water surface shall be performed monthly.

Necessary testing kits should be available for checking the pH and disinfectant residual. The person responsible for testing should be thoroughly familiar with the procedure for checking.

9.8.13 *Refuse Disposal*

The equipment provided for the storage, collection, and disposal of refuse produced at a swimming pool or bathing beach shall be such that the creation of conditions detrimental to public health, such as rodent harborage, insect breeding areas, odors, air pollution

and accidents are prevented. All refuse shall be stored in water-tight, metal or rigid plastic containers having tight-fitting lids. Containers shall be provided as needed throughout food preparation areas and eating areas to provide for enough collection of trash.

10 SWIMMING POOL USER'S RESPONSIBILITY

10.1 Should not enter the waters of the swimming pool without taking a bath and a foot bath in bath room on the swimming pool premises.

10.2 Should not use any oil or any other substances or preparation which may rendered the swimming pool water turbid or otherwise unfit for use of bathers.

10.3 Should not pollute the waters of the pool by spitting or in any other manner.

10.4 Not to use the swimming pool when suffering from skin disease or any other contagious diseases

10.5 To avoid choking, users should not chew gum or eat while swimming or playing in the pool. Users should not take alcohol or consume drugs immediately before swimming or playing in the pool.

Bureau of Indian Standards

BIS is a statutory institution established under the *Bureau of Indian Standards Act*, 1986 to promote harmonious development of the activities of standardization, marking and quality certification of goods and attending to connected matters in the country.

Copyright

BIS has the copyright of all its publications. No part of these publications may be reproduced in any form without the prior permission in writing of BIS. This does not preclude the free use, in the course of implementing the standard, of necessary details, such as symbols and sizes, type or grade designations. Enquiries relating to copyright be addressed to the Director (Publications), BIS.

Review of Indian Standards

Amendments are issued to standards as the need arises on the basis of comments. Standards are also reviewed periodically; a standard along with amendments is reaffirmed when such review indicates that no changes are needed; if the review indicates that changes are needed, it is taken up for revision. Users of Indian Standards should ascertain that they are in possession of the latest amendments or edition by referring to the latest issue of 'BIS Catalogue' and 'Standards : Monthly Additions'.

This Indian Standard has been developed from Doc No.: CHD 08 (2046).

Amendments Issued Since Publication

Amend No.	Date of Issue	Text Affected

BUREAU OF INDIAN STANDARDS

Headquarters:

Manak Bhavan, 9 Bahadur Shah Zafar Marg, New Delhi 110002

Telephones : 2323 0131, 2323 3375, 2323 9402

Website: www.bis.org.in

Regional Offices:

Central : Manak Bhavan, 9 Bahadur Shah Zafar Marg
NEW DELHI 110002

Telephones

{ 2323 7617
2323 3841

Eastern : 1/14 C.I.T. Scheme VII M, V. I. P. Road, Kankurgachi
KOLKATA 700054

{ 2337 8499, 2337 8561
2337 8626, 2337 9120

Northern : Plot No. 4-A, Sector 27-B, Madhya Marg, CHANDIGARH 160019

{ 26 50206
265 0290

Southern : C.I.T. Campus, IV Cross Road, CHENNAI 600113

{ 2254 1216, 2254 1442
2254 2519, 2254 2315

Western : Manakalaya, E9 MIDC, Marol, Andheri (East)
MUMBAI 400093

{ 2832 9295, 2832 7858
2832 7891, 2832 7892

Branches: AHMEDABAD. BENGALURU. BHOPAL. BHUBANESHWAR. COIMBATORE.
DEHRADUN. DURGAPUR. FARIDABAD. GHAZIABAD. GUWAHATI.
HYDERABAD. JAIPUR. JAMMU. JAMSHEDPUR. KOCHI. LUCKNOW. NAGPUR.
PARWANOO. PATNA. PUNE. RAIPUR. RAJKOT. VISAKHAPATNAM.