नोटबुक कम्प्यूटर के लिए
डीसी बिजली की आपूर्ति

dc Power Supply for
Notebook Computers

ICS 29.120; 35.180

© BIS 2016



भारतीय मानक ब्यूरो
BUREAU OF INDIAN STANDARDS
मानक भवन, 9 बहादुरशाह ज़फर मार्ग, नई दिल्ली-110002
MANAK BHAVAN, 9 BAHADUR SHAH ZAFAR MARG
NEW DELHI-110002
www.bis.org.in www.standardsbis.in

NATIONAL FOREWORD

This Indian Standard which is identical with IEC/TS 62700 : 2014 'DC power supply for notebook computers' issued by the International Electrotechnical Commission (IEC) was adopted by the Bureau of Indian Standards on the recommendation of the Audio, Video and Multimedia Systems and Equipments Sectional Committee and approval of the Electronics and Information Technology Division Council.

The text of IEC Standard has been approved as suitable for publication as an Indian Standard without deviations. Certain conventions are however not identical to those used in Indian Standards. Attention is particularly drawn to the following:

- a) Wherever the words 'International Standard' appear referring to this standard, they should be read as 'Indian Standard'.
- b) Comma (,) has been used as a decimal marker while in Indian Standards, the current practice is to use a point (.) as the decimal marker.

In this adopted standard, reference appears to certain International Standards for which Indian Standards are also exist. The corresponding Indian Standards, which are to be substituted in their places, are listed below along with their degree of equivalence for the editions indicated:

<i>International Standard</i>	<i>Corresponding Indian Standard</i>	<i>Degree of Equivalence</i>
IEC 60950-1 : 2005 Information technology equipment — Safety Part 1: General requirements	IS 13252 (Part 1) : 2010 Information technology equipment — Safety: Part 1 General requirements (<i>second revision</i>)	Identical
CISPR 22 Information technology equipment — Radio disturbance characteristics — Limits and methods of measurement	IS 6873 (Part 7) : 2012 Limits and methods of measurement of radio disturbance characteristics: Part 7 Information technology equipment (<i>second revision</i>)	Identical with CISPR 22 : 2008
CISPR 24 Information technology equipment — Immunity characteristics — Limits and methods of measurement	IS 15039 : 2001 Information technology equipment — Immunity characteristics — Limits and methods of measurement	Identical with CISPR 24 : 1997

The technical committee has reviewed the provisions of following International Standards referred in this adopted standard and has decided that they are acceptable for use in conjunction with this standard:

<i>International Standard</i>	<i>Title</i>
IEC 61076-2-102	Connectors for electronic equipment — Part 2-102: Circular connectors with assessed quality — Detail specification for plugs and jacks for external low voltage power supply
IEC 61204 : 1993	Low-voltage power supply devices, d.c. output — Performance characteristics
CISPR 32	Electromagnetic compatibility of multimedia equipment — Emission requirements

For the purpose of deciding whether a particular requirement of this standard is complied with the final value, observed or calculated, expressing the result of a test or analysis, shall be rounded off in accordance with IS 2 : 1960 'Rules for rounding off numerical values (*revised*)'. The number of significant places retained in the rounded off value should be the same as that of the specified value in this standard.

Indian Standard

dc POWER SUPPLY FOR NOTEBOOK COMPUTERS

1 Scope

This Technical Specification states the minimum requirements for DC power supply for notebook computers. Specifically, it gives

- an electrical specification (performance characteristics),
- an ID pin method,
- a connector for DC power output.

The no-load power and power efficiency are outside the scope of this Technical Specification.

Note that safety requirements are covered by IEC 60950-1 and EMC requirements are covered by CISPR 22 and CISPR 24. CISPR 32 may be used in place of CISPR 22 for this purpose. These requirements are neither re-stated nor challenged by this Technical Specification but the designer should give due consideration to the performance of the power supply when used with a compatible notebook computer.

NOTE Applications for use in aerospace, military, medical, or smart grid are not addressed in this Technical Specification.

2 Normative references

The following documents, in whole or in part, are normatively referenced in this document and are indispensable for its application. For dated references, only the edition cited applies. For undated references, the latest edition of the referenced document (including any amendments) applies.

IEC 60950-1:2005, *Information technology equipment – Safety – Part 1: General requirements*
Amendment 1:2009
Amendment 2:2013

IEC 61076-2-102, *Connectors for electronic equipment – Part 2-102: Circular connectors with assessed quality – Detail specification for plugs and jacks for external low voltage power supply*

IEC 61204:1993, *Low-voltage power supply devices, d.c. output – Performance characteristics*
Amendment 1:2001

CISPR 22, *Information technology equipment – Radio disturbance characteristics – Limits and methods of measurement*

CISPR 24, *Information technology equipment – Immunity characteristics – Limits and methods of measurement*

CISPR 32, *Electromagnetic compatibility of multimedia equipment – Emission requirements*

3 Terms, definitions and abbreviations

3.1 Terms and definitions

For the purposes of this document, the terms and definitions given in IEC 60950-1 as well as the following apply.

3.1.1

notebook computer

lightweight compactly designed computer with a screen and attached keyboard that is capable of running on battery power for extended periods of time and is relatively easy to transport from one location to another by a single individual

3.1.2

DC power supply

adapter

AC adapter

external power supply which provides DC to the notebook computer

3.1.3

DC output connector

connecting body to connect and disconnect the electrical interface between DC power supply and the notebook computer

3.1.4

DC output plug

male connector of DC output connectors for connecting the DC power supply

3.1.5

identification signal

ID signal

signal which enables communication between a DC power supply to a notebook computer

3.1.6

identification signal connector pin

ID pin

electrical connector pin to transport ID signal

3.2 Abbreviations

AC	Alternating Current
CPU	Central Processing Unit
EIAJ	Electronic Industries Association of Japan
EMC	Electromagnetic Compatibility
EMI	Electro Magnetic Interference
EUT	Equipment Under Test
LPS	Limited Power Supply
OEM	Original Equipment Manufacturer
PSE	Product Safety Electrical appliance and material
SPM	Smart Power Management
VCC	Voltage at the Common Collector

4 Electrical specification (performance characteristics)

4.1 AC input rating

The range of AC input rating acceptable by the power supply shall be stated and specified as (100 to 240) Vrms, 50/60 Hz. Operating tolerance shall be (90 to 264) Vrms at 47 Hz to 63 Hz to accommodate specific country/regional requirements. No further tolerances shall be applied.

4.2 Inrush current

The maximum inrush current, from power-on (with power on at any point on the AC sinewave) and including, but not limited to, three line cycles, shall be less than 220 A. The limit shall be met at the maximum input voltage and across both cold start (all components at minimum temperature) and hot start conditions (and after sustained operation at maximum rated power and ambient temperature).

4.3 DC output load condition and voltage regulation

There are still comments and concerns with respect to the DC output load conditions and voltage regulations. Informative text is given in Clause E.1.

4.4 DC output ripple and noise

The ripple and noise performance for DC output shall be stated and specified as maximum 600 mV peak-to-peak for steady state, except when no load is attached.

IEC 61204:1993, and its Amendment 1:2001, 3.10 "Periodic and random deviation" is applicable.

4.5 Output transient response and capacitor load

The transient response at the output terminal and the capacitor load of the power supply shall be stated. The capacitor load shall be specified as 2 200 μ F maximum.

IEC 61204:1993, 3.16 "Transient response to load current changes" is applicable.

4.6 Power supply timing

4.6.1 Turn on delay time

The time taken, after switch-on of the source, for the output voltage to enter the specification band, shall be stated and specified as less than 3 s maximum under all load conditions.

4.6.2 Hold-up time

The hold-up time shall be stated as more than 10 ms at 110 Vrms/50 Hz.

Note that a reference load should be considered in future work.

4.6.3 Rise time of output voltage

The rise time of output voltage shall be greater than 2 ms and less than 40 ms.

Note that a reference load should be considered in future work.

4.7 Protection

4.7.1 Over-current protection

There are still comments and concerns with respect to over-current protection. Informative text is given in Clause E.2.

4.7.2 Short-circuit protection

Short-circuit protection shall comply with IEC 60950-1.

4.8 Over shoot

During power on or power off, the output voltage shall not exceed 21 V peak nor be outside the regulation requirements for more than 10 ms.

Note that the maximum value shall be verified after further definition of 4.3.

5 DC power supply identification and communication method for notebook computers

This clause needs further investigation and development and is for information only. The use of the ID pin should be clearly defined (including pin configuration and communication mode). This Technical Specification has not addressed any definite method of communication between the AC adapter and computer, nor has the group yet discussed the scope of the data to be communicated.

Historically, AC adapters have commonly used mechanical interference of the DC connector to prevent incompatible combinations of AC adapters and notebook computers. Non-mechanical electrical methods (digital communication, voltage of the adapter, or analog reference) are in proprietary use today with some OEMs and work by identifying the AC adapter to the notebook computer. In general, the identification method is developed by each individual computer manufacturer and the methods used are different. On the other hand, there are many PCs and power supplies that do not use any identification protocol.

Further investigation is necessary in order to determine an identification method. To agree to a data communication protocol, data content and format is a complex task. Measures of robustness and integrity shall be used to help determine a minimum baseline of communication and allow for future evolution of this Technical Specification. Questions to answer are the following.

- Is an ID pin communication mandatory for functionality?
- When should it be acceptable for a computer to reject certain models of AC adapters?
- Which communications standard shall be used?
- What should the system do in the event of a failure of the communication?
- Can a scalable system of both low cost analog and higher function digital approaches be devised?
- Should the communication be bidirectional, or support networking of multiple devices?
- Which is the minimum information that shall be provided by the AC adapter? Which obligations does the notebook computer have to the AC adapter?
- What mechanism will allow for OEM specific innovation? To gain acceptance, the Technical Specification should not exclude innovative or proprietary solutions from manufacturers.
- What roadmap can be provided for future innovation in the communication method, or what process can be used for standardizing new data?

Simple analog methods (such as voltage positioning or presentation of a reference current on a dedicated pin) may be used to identify a few simple characteristics of the AC adapter (such as the announcement of the power output capability) to the notebook computer. Digital communication may be used to communicate more detailed information between the computer and AC adapter. EMI characteristics, power capabilities, or other details may be communicated to the computer to identify and even reject the usage of an unqualified AC adapter.

Health variables (such as reporting an over-temperature of the AC adapter) may require bidirectional signalling initiated by the AC adapter. Configurability of the AC adapter (for example, configuring output voltage) will require a read/write capability of the digital data. Lastly, the communication method may be desired to support proprietary OEM functionality beyond the scope or imagination of this Technical Specification.

Some typical methods used in notebook computers include

Class 1 ID:

The ID is a simple analog voltage. The adapter output voltage is a DC constant, and the notebook smart-power management (SPM) may get limited parameters such as voltage, power level, or even ripple, over-current protection, and over-power protection information by sensing the ID pin. Typical features include:

- the ID pin outputs an analog voltage. Thus, SPM can evaluate the voltage of the ID pin and quality, and make decisions on the acceptability of the adapter with the specific PC;
- SPM may make a dynamic adjustment to the notebooks power consumption by sensing the voltage drop on the ID pin.

Detailed information such as the manufacturer and specification information cannot viably be transmitted with a Class 1 ID, so it remains unknown to the PC.

Class 2 ID:

The ID is digital data stored in memory in the AC adapter. Static configuration reports such as parametric specifications, manufacturer, and safety certification information may be read using the ID. Typical features include the following.

- Data is transferred digitally. Transfers may be bidirectional.
- Any detailed information about the AC adapter can be stored in a known format.
- The AC adapter may store and transfer dynamic information such as total working hours and diagnostic records.
- The memory is read only. The AC adapter may not be reconfigured (for example, to another voltage) by the notebook.

Class 3 ID:

The ID pin is a digital power communication port which may allow configuration of the AC adapter by the notebook. The main features may be summarized as below.

- Digital power output parameters may be reconfigured according to the notebook command, for example, the output voltage can be changed from 16 V to 20 V.
- The protection alarm (for example, temperature, overcurrent, or overvoltage) and protection action signal may be sent mutually between the notebook and AC adapter.
- Include Class 2 ID features (static configuration reports of the AC adapter).

Communication methods may use a separate pin or may be imposed on the power lines (through AC modulation on the DC power line).

6 Connectors for DC power supply for notebook computer

6.1 General

The AC adapter may be provided with either a captive DC cable or with a replaceable DC cable. A captive cable has no provision for replacement by the end user and shall terminate in a male DC connector plug as described in Figure 1 and Table 1.

An AC adapter with a replaceable DC cable shall terminate with the female connector specified in 6.2.3. A cable assembly is required to connect the AC adapter to the notebook computer.

NOTE An alternative DC connector can be used if there is an optional means for the user to reconfigure the connector to comply with Figure 1.

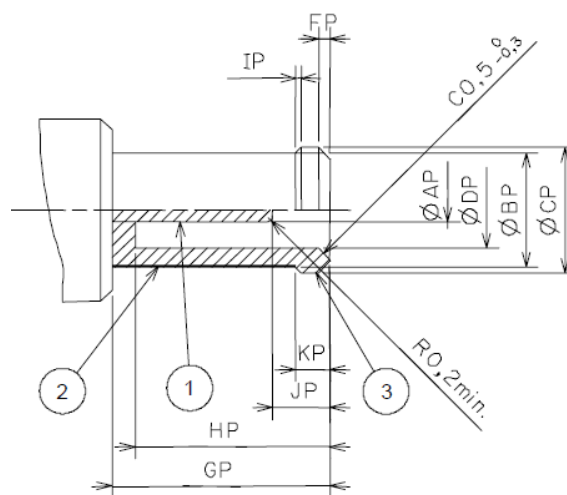

Key

- 1 Centre electrode P
- 2 Sleeve
- 3 Insulation collar

Figure 1 – Shape of the plug

Table 1 – Dimensions of the plug

Dimensions in millimetres

AP	BP	CP	DP	FP	GP	HP min.	IP	JP	KP
$1,0 \begin{smallmatrix} 0 \\ -0,1 \end{smallmatrix}$	$5,0 \begin{smallmatrix} +0,1 \\ 0 \end{smallmatrix}$	$5,5 \begin{smallmatrix} +0,1 \\ 0 \end{smallmatrix}$	$3,3 \begin{smallmatrix} +0,2 \\ 0 \end{smallmatrix}$	$0,5 \begin{smallmatrix} 0 \\ -0,3 \end{smallmatrix}$	$9,5 \pm 0,3$	8,5	$0,25 \pm 0,1$	$2,5 \pm 0,1$	$1,5 \pm 0,1$

NOTE In Japan, this plug is specified in the electrical appliance and material safety law of Japan to apply the voltage range of 10,5 V to 13,5 V only. Thin notebooks and tablet PCs use a smaller size of DC connector. The DC connector specified in Figure 1 does not suit thin notebooks and tablet PCs. Compatibility with backwards PCs will be taken into consideration.

6.2 Specification for DC connectors

6.2.1 General

The plug shown in Figure 1 shall terminate the end of an AC adapter with a captive cable. The DC connector enables 2 or 3 electrical connections (ground, VCC, and possibly a dedicated ID pin).

6.2.2 Shape and dimension of DC connectors

Recently, the notebook PC has become slimmer and thinner in accordance with market demand. The popular type of PC is moving from notebook to tablet. These trends are to be considered and further investigation is necessary.

A candidate for a mechanical DC connector is suggested in Figure 1. However, the 5,5 mm dimension will be too large for the current trend of thinner notebooks. A 4,5 mm connector would be appropriate for many thin computers, but may not have the current carrying capability for a 120 W adapter. A specification should make provisions to allow for a newly customized DC connector/jack combination, if so desired.

6.2.3 Voltage polarity and electrical specification of DC connectors

The outside electrode of the DC output connector shall have a negative (-) polarity and the centre electrode shall have a positive (+) polarity.

NOTE The electrical specification for a DC output connector and a measuring method are not yet determined. Typically, a DC resistance of 30 m Ω is expected from a mated pair. But since the DC connector and jack may be supplied by different vendors, a method of measuring mated DC resistance or current handling capability is not available for this Technical Specification.

6.3 Cable qualities

6.3.1 General

Cable length and construction affect the voltage regulation and the noise emission of the cable. A universal method of EMI mitigation is yet undetermined in this Technical Specification. For example, ferrite common mode chokes are commonly required to limit conducted emissions. A predictable placement and specification of the ferrite is essential for consistent operation.

Neither length, color, texture, diameter nor aesthetic design of the cable are addressed by this Technical Specification.

6.3.2 Special considerations for an AC adapter with replaceable cable

An AC adapter with replaceable cable shall terminate in a female connector on the adapter body compatible to the plug of Figure 1. To connect the AC adapter body to the notebook, a cable shall have at least one end with a DC connector plug described in Figure 1. The other cable end (attaching to the computer) may terminate with a DC connector plug shown in Figure 1, or of a proprietary type suited to the computer OEM. The user may replace the cable, for example for storage or for maintenance.

The resistance of a replaceable cable shall be predictable. This Technical Specification has not addressed the issues related to a replaceable cable, but a replaceable cable shall be understood in terms of its insertion resistance and inductance. Excessive resistance will cause power loss and DC ground shift. Excessive inductance can cause overvoltage to the computer and result in sparking during disconnection (which can cause wear on the connector) or component damage in the computer.

Annex A
(informative)

Summary of discussion in project team IEC 62700

The summary below provides background information concerning the development of this Technical Specification.

Following Korea's domestic activities to consider common adapters for notebook computers, the Korean NC (KR) invited the international community to participate towards a standard that would address consumer convenience (through interoperability) and reduce E-waste (by encouraging re-use of a non-obsolete power supply). Recognizing the importance of establishing such an international standard, the Korean NC invited global industry and technology experts to participate in developing a safe and effective IEC standard.

a) History of progress

- New work item proposal 100/1699/NP was circulated on 2010-02-19.
- The NP was approved on 2010-09-17 (100/1753/RVN).
- The project team received comments submitted by National Committees on the NP (New work item Proposal), and agreed to get real data based on the agreed measurement methods.
- Having had face-to-face meetings several times since 2010, and receiving and discussing real measured data, the target date for first CD (Committee Draft) was extended two times in an attempt to clarify remaining comments.

b) The decision to develop a technical specification instead of an international standard

There are still comments and concerns in the NP which have not yet been resolved. These include issues with the proposed NP for international standards which have been identified by the project expert members, including major PC manufacturers. The project team believes more time is needed to understand and address the technical issues.

Based on the remaining issues, the project team was concerned that it would be difficult to reach consensus to develop an International Standard within the program work time period.

The project team decided to continue the discussion on e-waste and the resolution of technical challenges in order to move forward.

c) Considered aspects

The following is a summary of aspects considered by the project team IEC 62700. The details are shown in Annex C and Annex D.

1) Technical innovation / Advancement of technologies for PC systems

Innovative technologies are actively under development to improve power efficiency of PC systems. IEC work intends to support continuing innovation.

2) Product development cost and maintenance costs

The project team is mindful of the potential implementation and support costs to industry. The publication of an international standard should be carefully considered as responsible to the market requirements.

3) Feasibility for the reduction of the resource and e-waste

Shipment of the PC along with the AC adapter will be continued to meet regulatory and other market requirements. The project team does not suggest a certain reduction in e-waste by virtue of a common AC adapter.

4) Risk in system reliability, risk for consumers

The use of untested combinations of PC and third party AC adapters may cause unexpected problems and unknown business liability issues. Performance, reliability and safety for consumers are important.

5) Exploration and resolution of technical challenges

Issues in safety and EMC are being addressed. Additionally, relevant electro-mechanical characteristic issues have been identified and require further exploration.

Annex B
(informative)

Ad-hoc activities

Measured data for the limited combinations between AC adapters and notebook computers are listed below.

Korea (KR), Japan, US and Ireland expert members participated in these ad-hoc activities.

a) Korean expert members submitted EMI measurement results tested in accordance with CISPR 22 as specified below.

1) EUT

AC adapter: 4 units, notebook PC: 3 units

Battery charging condition in notebook PC: 10 % and 100 %

NOTE AC adapters and notebook PCs are commonly available market products.

2) Measured combinations

Radiated emission: 48 combinations

Conducted emission on AC lines: 48 combinations

Conducted emission on LAN Port: 48 combinations

3) Result: Reduced margins were measured with the following 4 combinations.

A0: AC adapter, L2, L5: Notebook PC

The diagrams of these measurements are shown in Figure B.1 and Figure B.2.

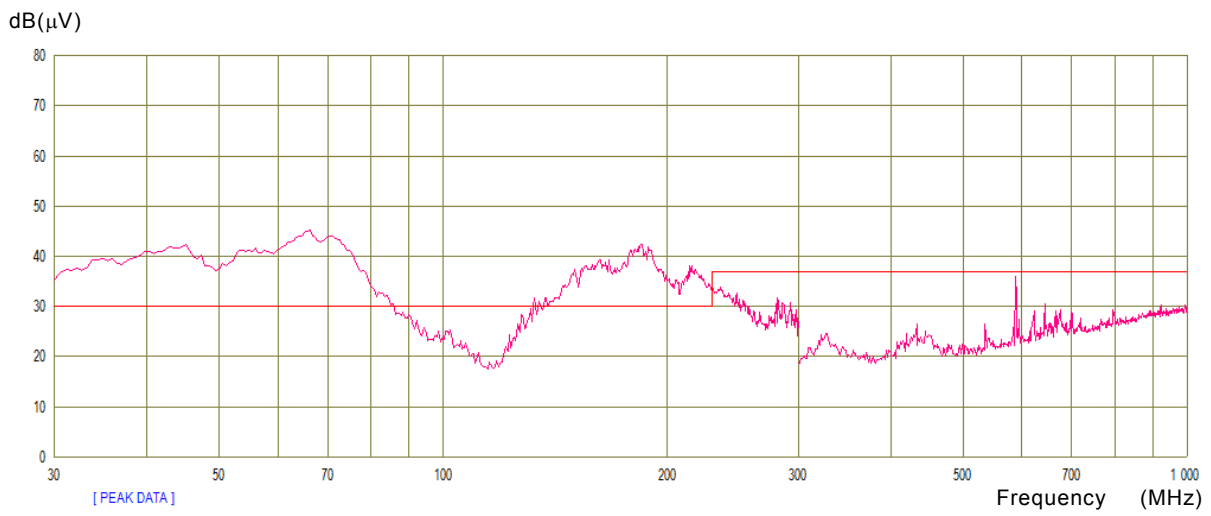

Figure B.1a – A0 with L2 charging 10 %

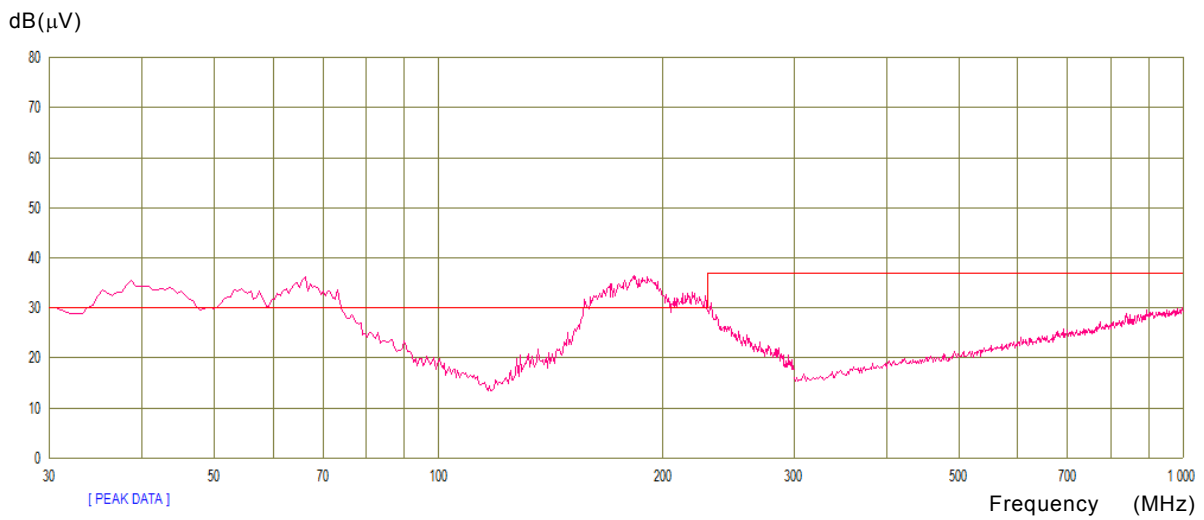

Figure B.1b – A0 with L5 charging 10 %

Figure B.1 – Radiated emission

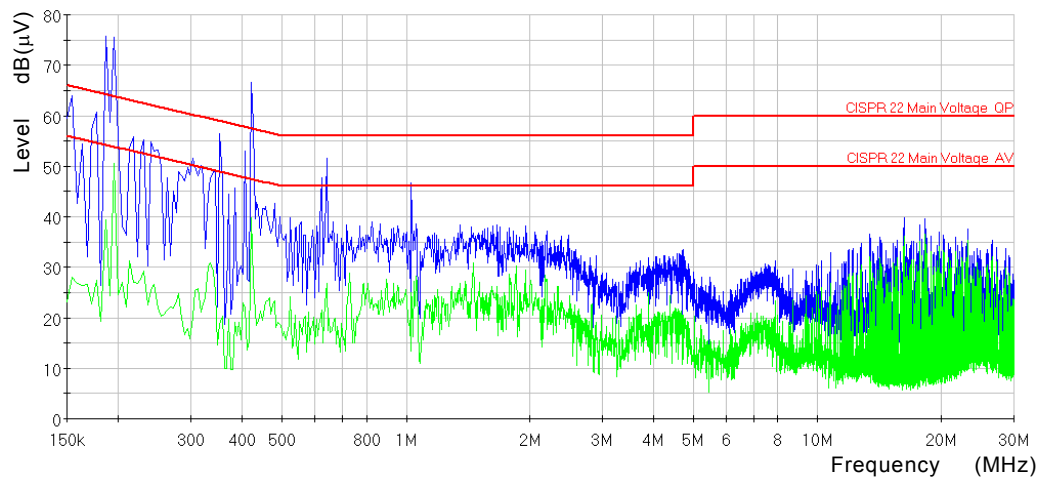

Figure B.2a – A2 with L2 Charging 100 %_Neutral

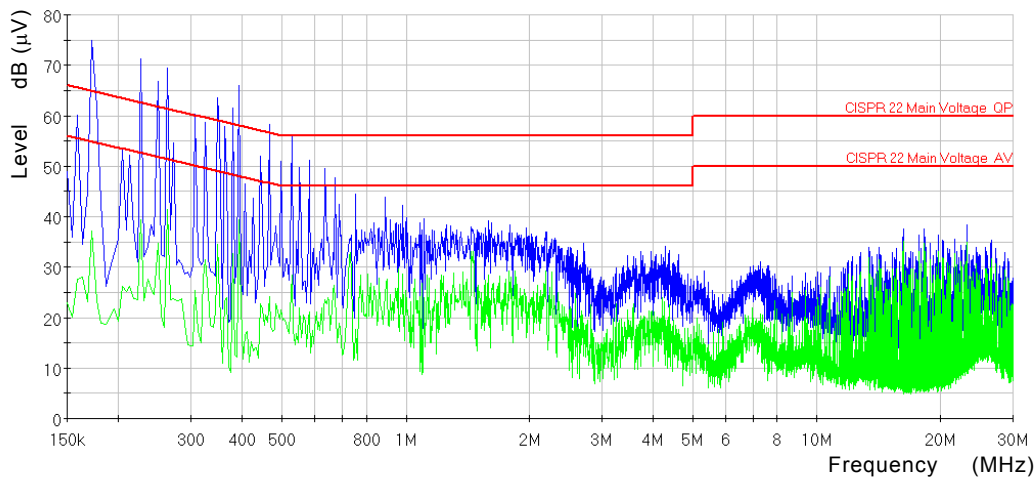

Figure B.2b – A2 with L4 Charging 100 %_Live

Figure B.2 – Conducted emission

b) Japan expert members submitted EMI measurement results tested in accordance with CISPR 22 as specified below.

1) EUT

AC adapter: 8 units, Notebook PC: 7 units

Battery charging condition in notebook PC: 100 %.

NOTE AC adapters and notebook PCs are commonly available market products.

2) Measured combinations

Radiated emission: 19 combinations

Conducted emission on AC lines: 14 combinations

3) Result: Reduced margins were measured with one combination as follows.

The diagrams of these measurements are shown in Figure B.3.

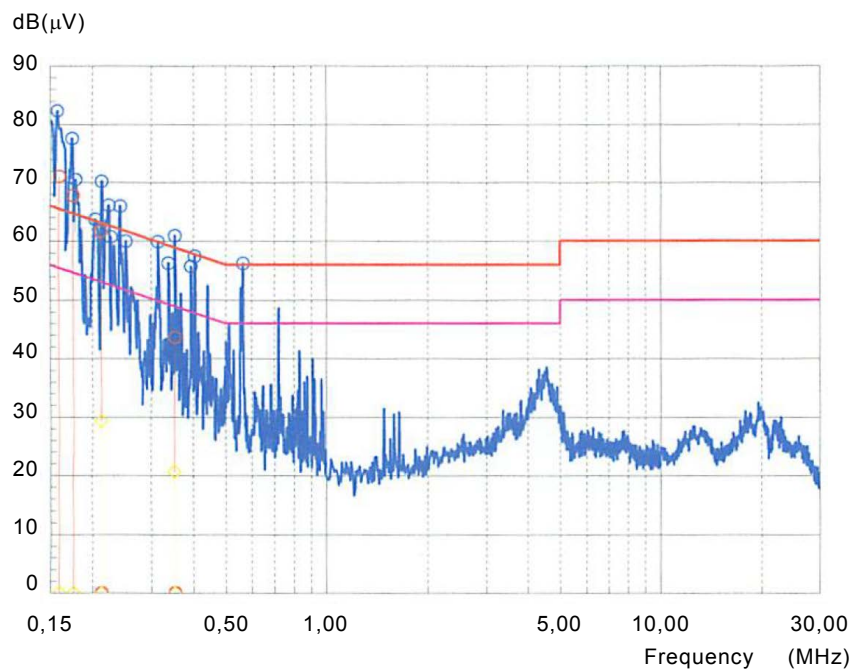

Figure B.3 – Conducted emission

c) Conclusion

- 1) There is not much difference in the conducted emission testing with several combinations according to CISPR 22.
- 2) Regarding the radiated emission test, the data measured from Japan and Korea with respect to the limit specified in CISPR 22 were satisfactory.
- 3) The reduced margin for some combinations of adapters and PCs remains a concern. Further investigation may be necessary to characterise this issue.
- 4) See Clause C.2 for further information regarding EMC considerations.

Annex C (informative)

AC adapters used with notebook computers – Areas to be investigated

C.1 Safety

An adapter and notebook combination supplied by a single manufacturer is designed to be compatible and to work together as comprehensive system in accordance with safety standards. If an adapter designed to meet this Technical Specification is used with a third party notebook, a specific assessment of the resulting combination may be necessary to ensure that it will function safely within the meaning of the applicable product safety standard. Issues of compatibility and user safety as described in Clause D.1 were discussed but a technical solution has not been found yet.

C.2 EMC

The EMC levels of emissions and the immunity of adapters are dependent on the host system. EMI was measured with combinations of adapters and PCs by an Ad hoc group of the project team IEC 62700 using CISPR 22, but a conclusion of how to guarantee the EMC compliance when an adapter designed to meet this Technical Specification is connected to any host PC could not be found. See Clause D.2.

NOTE This Technical Specification does not yet suggest a reliable method of ensuring compliance for anonymous combinations of AC adapters and notebook computers. DC power supplies for notebook computers are tested and shown to be compliant with IEC 61000-3-2, IEC 61000-3-3, CISPR 22 (or CISPR 32) and CISPR 24. This group has observed some anecdotal results of combinations of AC adapters and computers, but has not reached a satisfactory solution that ensures EMC compliance of the notebook computer when arbitrary combinations of DC power supplies are used.

C.3 Future trends in connectivity and power delivery

Power delivery for portable information devices (computers, tablets, phones) is continuously evolving. One trend is new technology which combines data transport with high power delivery. An example is the USB power delivery specification which now supports up to 100 W of bidirectional power (sink/source) and up to 5 Gbit/s of data transport over USB3. Such new technologies provide single cable solutions that will enable new use cases such as enhanced adapters with docking station functionalities where the adapters not only deliver power to the information device, but also connectivity to the infrastructure (displays, networking, I/O). Trends in connectivity include combinations of I/O connectors and the reduction of different types of connectors needed to be carried by end users to support different use cases (from simple single device charging, to multiple device powering and data communication).

Annex D (informative)

Expected issues when any adapter is connected to any host PC

D.1 Safety issues

D.1.1 Over-voltage protection

Components used in the power path of a PC where an AC adapter is connected have a rated voltage. If a failure in the AC adapter occurs and causes an over-voltage to the components in the power path of the PC, catastrophic system damage or a fire hazard may occur.

D.1.2 Over-current protection and short circuit protection

If the input circuit of the PC load is short-circuited at an unfused point, an unspecified AC adapter without overcurrent protection or overvoltage protection may result in damage, smoke or fire. However, if protection is provided on the AC adapter, the step load of the sink during normal operation may falsely trigger the protection circuit in the AC adapter and cause a loss of functionality in the system. Matching the requirements of the sink and source are essential for normal operation and also protection against exceptional failure.

D.1.3 Leakage current

Notebook computers with metal chassis have become common. These metal surfaces require due care by the manufacturer to reduce the risk of electric shock. The leakage limits stated by IEC 60950-1 may be above the threshold for pain or discomfort for some users, and mitigation AC adapter leakage is viewed as an essential part of the system quality.

D.1.4 Peak current

Because of the power management in a notebook computer, the difference between the average power and the peak power of the PC (for example, the load step when a high power CPU transitions from idle to busy, or during bursty “Turbo” operation) is very large. The practice of supporting peak currents which exceed the nominal rated current during limited periods is common in tested source and sink combinations. If the AC adapter does not support the peak input current required by the PC, the AC adapter will be overloaded and may result in loss of function, damage to the AC adapter or notebook, smoke or fire.

D.1.5 Surge and ringing

Combinations of the inductance of AC adapter's DC cable and the load capacitance in the PC can cause a voltage fluctuation on the cable during current transitions caused by the sink. Overvoltage protection on the AC adapter is essential to avoid the risk of damage due to those voltage spikes. Also, the cable inductance and current step transitions shall be bounded in the PC sink. Not all PC makers have addressed this issue today.

D.1.6 Surface temperature of enclosure of AC adapters

If an AC adapter is loaded to a power level above the rated current, but less than the “over current protection”, the AC adapter may heat excessively. This heating may increase the surface case temperature of the AC adapter and lead to discomfort or burn to the human body if touched, or result in deformation, discoloration or even failure of the AC adapter.

D.1.7 Risk of electric shock

A PC with an integral negative-ion generator has been commercialized before, and there is a future likelihood of the use of negative-ion (corona wind) cooling systems in notebook

computers. The AC adapters for these systems require circuitry for discharging between the primary and secondary sides. If an AC adapter that doesn't have the discharging resistor is used with the PC, then operators may receive an electric shock after touching metal on the PC chassis.

D.2 EMC issues

D.2.1 Load change

An AC adaptor shall support a wide range of load current. To save power and increase efficiency, the AC adapter controls such features as PFC, switching frequency, or will alternate between skip mode and continuous mode, and so on in accordance with the PC's load change. These changes in mode influence the EMC of the system. Traditionally, the acceptability of the solution shall be confirmed by an EMC test with a specific combination of PC and AC adaptor. In shipping products today, EMC test failures are known even when using otherwise functionally and parametrically compatible combinations of AC adapters and PCs.

D.2.2 Input power circuit of PC

EMC characteristics of the AC adapter depend on common mode filtering in the PC. EMC of the AC adapter degrades and noise of PC is radiated through the AC adapter and AC mains if the common mode filter in the PC is not appropriate. In some systems, additional countermeasures are required on the AC adapter. Common mode filtering performance as a system relies on specific knowledge of both the sink and source.

D.3 Environment issues

D.3.1 Inrush current

The failure instance of the AC adaptor will increase if the inrush current of PC is not specified and accommodated in the AC adapter. The inrush current by the sink that exceeds the AC adapters design may cause damage to the AC adapter and result in a waste of the resource.

D.3.2 General specifications

AC input specifications (voltage, frequency, and load change, etc.), DC output specifications (ripple noise, recovery method from short-circuited, etc.), and environmental specifications (allowed ambient temperature, vibration, impact, etc.) have been decided by each company uniquely, often in response to local market requirements. Failure or damage of the AC adaptor or PC happens frequently when these specifications are not met, resulting in a waste of the resource.

D.3.3 High-efficiency technology

Technology for AC adapters continues to evolve, especially benefitting the efficiency and decreasing the power consumed at low and zero loads. The objective to reduce e-waste by perpetually reusing older technology AC adapters should be weighed against the advantage in power savings using replacement adapters made with improved technology.

D.4 Reliability and quality issues

D.4.1 Life time

The life time of AC adapters is largely determined by the life time of its electrolytic capacitors. Each PC maker decides on the life time of electrolytic capacitors considering how many years the PC is used. If one AC adapter is used for several PCs, the life time becomes shorter. Then the AC adapter is broken at an early time. Also, a DC cord is broken by bending or twisting many times.

D.4.2 Extraordinary noise

To decrease power consumption, the AC adapter controls operations such as PFC ON or OFF, switching frequency, skip mode or continuous mode and so on in accordance with PC's load change. Each control or transition may cause an acoustically audible noise. Even if a common standard is agreed upon for audible noise, the customer may complain to the provider of the PC maker about this sensitive issue.

D.5 Standards issues

D.5.1 Environments

Power savings initiatives (such as Energy Star Programme originated by the Environmental Protection Agency for energy efficient office equipment or EuP COC) rely on aggressively reducing the power consumption of the system as a whole (including both AC adapter and notebook). The limits for power consumption will be periodically tightened, sometimes per country. Combinations of old AC adapters and latest PCs may not satisfy these upcoming regulations.

D.5.2 EMC evaluation

Untested combinations of AC adapters and PCs are not recognized by CISPR. According to the requirements of CISPR 22 and CISPR 24, the evaluation shall be done by a specific combination of PC and AC adapter. If any other AC adapters are used, the PC evaluation shall be repeated using each of the other AC adapters.

D.5.3 EMC class

According to the requirements of CISPR 22, a Class B PC may not be used with a Class A AC adapter.

D.5.4 Safety evaluation

According to the requirements of IEC 60950-1, evaluation shall be done by a specific combination of PC and AC adapter. If any other AC adapters are used, the evaluation shall be repeated using each of the other AC adapters.

D.5.5 LPS requirements

According to the requirements of IEC 60950-1, 120 W AC adapter (non-LPS) is prohibited to use with a PC sold with an LPS AC adapters. The reason is that HB40 and HB75 class material may be used for an LPS system.

Material of V-1 or higher is required for the PC enclosure if the AC adapter is non-LPS (IEC 60950-1:2005, 4.7.2.1 and 4.7.3.2). HB40 and HB75 class material is allowed for PC enclosure if the AC adapter is LPS (IEC 60950-1:2005, 4.7.2.2).

D.5.6 Plug

The 5,5 mm EIAJ plug suggested in 6.3 is allowed for use only between 10,5 V to 13,5 V by IEC 61076-2-102 and Japan PSE law. The purpose of the limitation is to protect incumbent devices from high voltage of more than 13,5 V.

D.5.7 Marking of electrical ratings on PC

The customer may have trouble identifying which AC adapter is compatible with their PC. Subclause 1.7.1 of IEC 60950-1:2005, Amendment 1:2009 and Amendment 2:2013 does not require marking of input ratings to DC operated equipment (PC). So the customer will have

difficulty in identifying which current rating (3,42 A, 4,74 A or 6,32 A) of the AC adapter should be used.

D.6 Other issues

The overmold of the DC OUTPUT PLUG of the AC adapter shall be specified in order to avoid mechanical interference when inserted into the PC. Since the location and orientation of the DC jack on the PC may cause interference with the surface the PC is placed on, the dimension of the DC plug overmold shall be specified.

Annex E (informative)

Electrical specification

E.1 DC output load condition and voltage regulation

The contributors to this Technical Specification recognize that several influences continue to shape the notebook computer market. Each of these shall be considered in order to insure relevance of a Standard in the future.

- The wide variety of market demands and the trend to highly mobile products: Legacy notebooks varied in power from 65 W to over 100 W. Though the needs for high power (over 100 W) systems remain, the trend in industry puts much greater focus on smaller and lighter PCs. The recent demand for the 40 W, 10 V UltraBook™¹ type of PCs and the 20 W, 5 V tablet demonstrates a trend towards lower power computing, and the distinction between notebook and tablet is becoming increasingly ambiguous.
- The increasing attention to environmental stewardship: this Technical Specification recognizes local initiatives (such as Energy Star or EuP) that aim to progressively decrease system power consumption. Though this Technical Specification does not address efficiency or no-load power consumption requirements directly, this Technical Specification shall be responsive to supporting the increasing focus on these parameters. A fixed voltage input of 19 V represents the state of the legacy notebook industry, but is restrictive and does not take advantage of the industry market trend for power savings at lower voltages and lower power levels. Establishing flexibility and mechanisms that allow for lower voltages is essential for a standard.
- Customer needs including cost and backwards compatibility: Most OEMs have established families of AC adapters actively in use by their customers. Only a smooth transition from the installed bases of proprietary installations to any new standard will avoid obsoleting the legacy installation and causing the type of e-waste this Technical Specification seeks to avoid. Cost of the implementation is also a key consideration. Since the prices paid for notebook computers continue to decline, cost efficiency is critical to gain widespread adoption of a standard.
- The need for opportunity in future innovation: The contributors to this Technical Specification recognize that a rigid, inflexible specification could inhibit deployment of new and compelling features or methods that improve efficiency, cost, or ease of use. The contributors recognize that any standard shall both establish a clear and reliable foundation of technical implementation and interoperability, but to be successful shall also allow a framework that allows for OEM specific innovation and forward growth.

Therefore, it is suggested that support for multiple voltages be accommodated with the following.

- Review of the scope of the standard, expanding from the original 65 W to 120 W scope to include some broader consideration that encompasses lower power devices.
- Some methodology that allows for fixed lower voltages or flexibility in the voltage delivered by the AC adapter.

Some discussion of the expected power trend for the industry may lead to a standard that recognizes separate classes of devices beyond the three power ranges (65 W, 90 W, and 120 W) that were relevant in 2010 when this initiative was formed.

¹ Ultrabook is the trademark of a product supplied by Intel Corporation.

This information is given for the convenience of users of this Technical Specification and does not constitute an endorsement by IEC of the product named. Equivalent products may be used if they can be shown to lead to the same results.

E.2 Over-current protection

Power management in the PC has evolved so that the power consumption of a notebook computer is highly dynamic. Power of the CPU complex is demand-based, so depending on the user application, the power consumption of a PC can vary from just tens of milliwatts in idle mode and step to tens of watts in less than a millisecond. To increase performance without compromising the size and weight, modern notebook PCs employ “Turbo” functionality (supporting high speed burst operation at high power consumption for short durations) and rely on power supply methods that temporarily demand power greatly in excess of the label rating of the AC adapter.

During this trend in performance of the notebook, the market expectations for the notebook AC adapter are increasingly influenced by the small AC adapters used for low power devices such as cell phones and slates. The market trend for notebook AC adapters is increasingly focused on physically small adapters with significant peak power capabilities.

Over-current protection in the AC adapter shall consider the notebook requirements during the events of initial connection and step change during normal operation and distinguish normal behaviour from system failure. Slew rate of the current transition, peak current, integral current and absolute duration shall all be considered. Capabilities of each of these in the AC adapter shall be known to the PC load, so either expected (through a minimum requirement) or announced over the ID mechanism.

Bibliography

IEC 61000-3-2, *Electromagnetic compatibility (EMC) – Part 3-2: Limits – Limits for harmonic current emissions (equipment input current ≤ 16 A per phase)*

IEC 61000-3-3, *Electromagnetic compatibility (EMC) – Part 3-3: Limits – Limitation of voltage changes, voltage fluctuations and flicker in public low-voltage supply systems, for equipment with rated current ≤ 16 A per phase and not subject to conditional connection*

USB Power Delivery Specification Rev. 1.0, Version 1.2
USB Implementers Forum, June 26, 2013

Bureau of Indian Standards

BIS is a statutory institution established under the *Bureau of Indian Standards Act, 1986* to promote harmonious development of the activities of standardization, marking and quality certification of goods and attending to connected matters in the country.

Copyright

BIS has the copyright of all its publications. No part of these publications may be reproduced in any form without the prior permission in writing of BIS. This does not preclude the free use, in course of implementing the standard, of necessary details, such as symbols and sizes, type or grade designations. Enquiries relating to copyright be addressed to the Director (Publications), BIS.

Review of Indian Standards

Amendments are issued to standards as the need arises on the basis of comments. Standards are also reviewed periodically; a standard along with amendments is reaffirmed when such review indicates that no changes are needed; if the review indicates that changes are needed, it is taken up for revision. Users of Indian Standards should ascertain that they are in possession of the latest amendments or edition by referring to the latest issue of 'BIS Catalogue' and 'Standards: Monthly Additions'.

This Indian Standard has been developed from Doc No.: LITD 07 (3475).

Amendments Issued Since Publication

Amendment No.	Date of Issue	Text Affected

BUREAU OF INDIAN STANDARDS

Headquarters:

Manak Bhavan, 9 Bahadur Shah Zafar Marg, New Delhi 110002

Telephones: 2323 0131, 2323 3375, 2323 9402

Website: www.bis.org.in

Regional Offices:

Telephones

Central : Manak Bhavan, 9 Bahadur Shah Zafar Marg
NEW DELHI 110002

{ 2323 7617
2323 3841

Eastern : 1/14, C.I.T. Scheme VII M, V.I.P. Road, Kankurgachi
KOLKATA 700054

{ 2337 8499, 2337 8561
2337 8626, 2337 9120

Northern : SCO 335-336, Sector 34-A, CHANDIGARH 160022

{ 260 3843
260 9285

Southern : C.I.T. Campus, IV Cross Road, CHENNAI 600113

{ 2254 1216, 2254 1442
2254 2519, 2254 2315

Western : Manakalaya, E9 MIDC, Marol, Andheri (East)
MUMBAI 400093

{ 2832 9295, 2832 7858
2832 7891, 2832 7892

Branches: AHMEDABAD. BENGALURU. BHOPAL. BHUBANESHWAR. COIMBATORE.
DEHRADUN. FARIDABAD. GHAZIABAD. GUWAHATI. HYDERABAD. JAIPUR. KOCHI.
LUCKNOW. NAGPUR. PARWANOO. PATNA. PUNE. RAJKOT. VISAKHAPATNAM.

Published by BIS, New Delhi