

भारतीय मानक  
Indian Standard

IS 16637 (Part 10) : 2018  
ISO 5610-10 : 2014  
(Superseding IS 14866 : 2000)

---

---

अनुभाजनीय निवेश्यों के लिये आयताकार  
टांग वाले उपकरण धारक

भाग 10 प्रकार एन

**Tool Holders with Rectangular  
Shank for Indexable Inserts**

Part 10 Style N

ICS 25.100.01

© BIS 2018



भारतीय मानक ब्यूरो

BUREAU OF INDIAN STANDARDS

मानक भवन, 9 बहादुरशाह ज़फर मार्ग, नई दिल्ली-110002

MANAK BHAVAN, 9 BHADUR SHAH ZAFAR MARG

NEW DELHI-110002

[www.bis.gov.in](http://www.bis.gov.in) [www.standardsbis.in](http://www.standardsbis.in)

May 2018

Price Group 5

## NATIONAL FOREWORD

This Indian Standard (Part 10) which is identical with ISO 5610-10 : 2014 'Tool holders with rectangular shank for indexable inserts — Part 10: Style N' issued by the International Organization for Standardization (ISO) was adopted by the Bureau of Indian Standards on the recommendation of the Cutting Tools Sectional Committee and approval of the Production and General Engineering Division Council.

This standard was earlier published as IS 14866 : 2000 'Single point tool holders for turning and copying for indexable inserts — Dimensions' identical with ISO 5610 : 1998. As ISO has revised its standard in 2014 in fifteen parts. Now the committee has decided to adopt this standard in fifteen parts by superseding IS 14866 : 2000. After the publication of this standard IS 14866 : 2000 shall be treated as withdrawn.

This standard is published in 15 parts. Other parts of this standard are:

- Part 1 General survey, correlation and determination of dimensions
- Part 2 Style A
- Part 3 Style B
- Part 4 Style D
- Part 5 Style F
- Part 6 Style G
- Part 7 Style J
- Part 8 Style K
- Part 9 Style L
- Part 11 Style R
- Part 12 Style S
- Part 13 Style T
- Part 14 Style H
- Part 15 Style V

The text of ISO Standard has been approved as suitable for publication as an Indian Standard without deviations. Certain conventions are, however, not identical to those used in Indian Standards. Attention is particularly drawn to the following:

- a) Wherever the words 'International Standard' appear referring to this standard, they should be read as 'Indian Standard'.
- b) Comma (,) has been used as a decimal marker while in Indian Standards, the current practice is to use a point (.) as the decimal marker.

This standard also makes a reference to the BIS Certification Marking of the product. Details of which are given in National Annex A.

*(Continued on third cover)*

*Indian Standard*

TOOL HOLDERS WITH RECTANGULAR  
SHANK FOR INDEXABLE INSERTS

PART 10 STYLE N

## 1 Scope

This part of ISO 5610 specifies tool holders with rectangular shank, style N, i.e. with straight shank and cutting edge angle  $\kappa_r = 63^\circ$  for side cutting.

These tool holders are primarily intended for indexable inserts made of hard metal or other cutting materials to be mounted by clamping and to be used for turning operations.

NOTE The symbols for the dimensions shown in the tables of this part of ISO 5610 and the corresponding preferred symbols of properties defined in ISO/TS 13399-2 and ISO/TS 13399-3 are given in ISO 5610-1:2014, Table A.1.

## 2 Normative references

The following documents, in whole or in part, are normatively referenced in this document and are indispensable for its application. For dated references, only the edition cited applies. For undated references, the latest edition of the referenced document (including any amendments) applies.

ISO 5608:2012, *Turning and copying tool holders and cartridges for indexable inserts — Designation*

ISO 5610-1:2014, *Tool holders with rectangular shank for indexable inserts — Part 1: General survey, correlation and determination of dimensions*

## 3 Dimensions

### 3.1 General

It is not necessary for tool holders to comply with the pictorial representation; only the dimensions given shall be observed.

For determination of dimensions  $h_1$ ,  $f$ , and  $l_1$ , see ISO 5610-1.

For explanation of the designation code for tool holders, see ISO 5608.

NOTE The values of rake angles and inclination angles shown in the figures are recommended values; they can vary according to the application.

3.2 Tool holder style N for rhombic indexable insert shape D

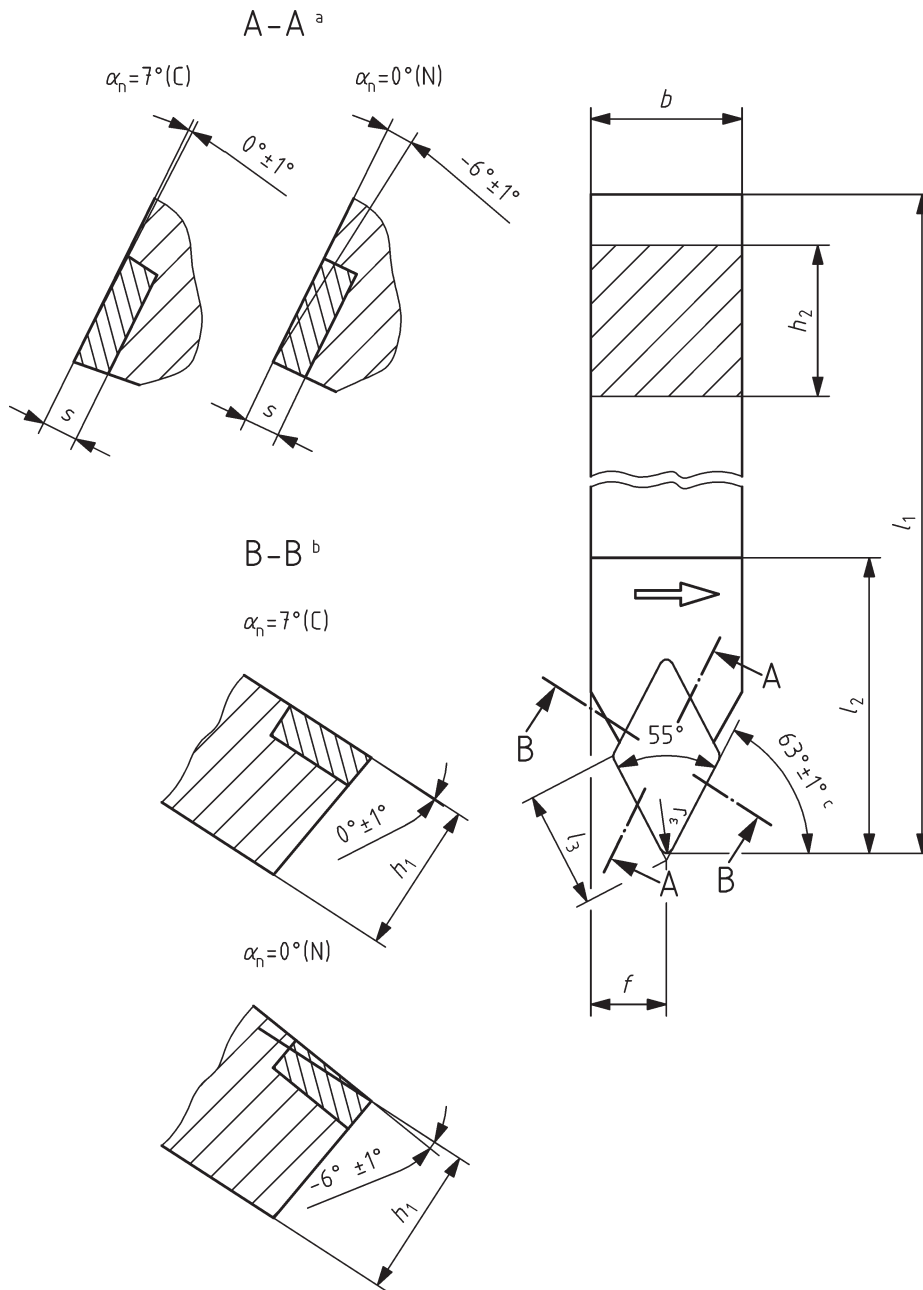

**Key**

- a Inclination angle,  $\lambda_s$ .
- b Rake angle,  $\gamma_0$ .
- c Neutral tool holders, note c of [Table 1](#).

NOTE This figure shows a right-hand tool holder (R); left-hand tool holder (L) laterally reversed.

**Figure 1 — Tool holder style N for rhombic indexable insert — D**

**Table 1**

Dimensions in millimetres

Symbol <sup>a</sup>	$h_1$ js13	$b$ h13	$l_3$ ≈	$f$ +0,5 0	$h_2$ h13	$l_1^a$ k16	$l_2$ max.	$s^b$
SDNCR 0808 — 07	8	8	7,75	4	8	—	25	2,38
SDNCL 0808 — 07								
SDNCN 0808 — 07 <sup>c</sup>								
SDNCR 1010 — 07	10	10	7,75	5	10	—	25	2,38
SDNCL 1010 — 07								
SDNCN 1010 — 07 <sup>c</sup>								
SDNCR 1212 — 07	12	12	7,75	6	12	—	25	2,38
SDNCL 1212 — 07								
SDNCN 1212 — 07 <sup>c</sup>								
SDNCR 1616 — 11	16	16	11,6	8	16	—	32	3,97
SDNCL 1616 — 11								
SDNCN 1616 — 11 <sup>c</sup>								
SDNCR 2020 — 11	20	20	11,6	10	20	—	32	3,97
SDNCL 2020 — 11								
SDNCN 2020 — 11 <sup>c</sup>								
SDNCR 2020 — 15	20	20	15,5	10	20	—	40	4,76
SDNCL 2020 — 15								
SDNCN 2020 — 15 <sup>c</sup>								
PDNNR 2020 — 15								
PDNNL 2020 — 15								
SDNCR 2525 — 15	25	25	15,5	12,5	25	—	40	4,76
SDNCL 2525 — 15								
SDNCN 2525 — 15 <sup>c</sup>								
PDNNR 2525 — 15								
PDNNL 2525 — 15								
SDNCR 3225 — 15	32	25	15,5	12,5	32	—	40	4,76
SDNCL 3225 — 15								
SDNCN 3225 — 15 <sup>c</sup>								
PDNNR 3225 — 15								
PDNNL 3225 — 15								
SDNCR 4032 — 15	40	32	15,5	16	40	—	40	4,76
SDNCL 4032 — 15								
SDNCN 4032 — 15 <sup>c</sup>								
PDNNR 4032 — 15								
PDNNL 4032 — 15								

<sup>a</sup> For the selection of length,  $l_1$ , the dash can be replaced by the dimensions of ISO 5610-1:2014, Table 2. For letter symbols identifying the tool length, see ISO 5608:2012, Table 6.

<sup>b</sup> Insert thickness without shim, if applicable.

<sup>c</sup> Tool holder for use in both directions of feed. The cutting edge angle  $\kappa_r = 62,5^\circ \pm 1^\circ$  and the tolerances  $\pm 0,25$  mm on dimension  $f$  apply for this design.

3.3 Tool holder style N for triangular indexable insert shape T

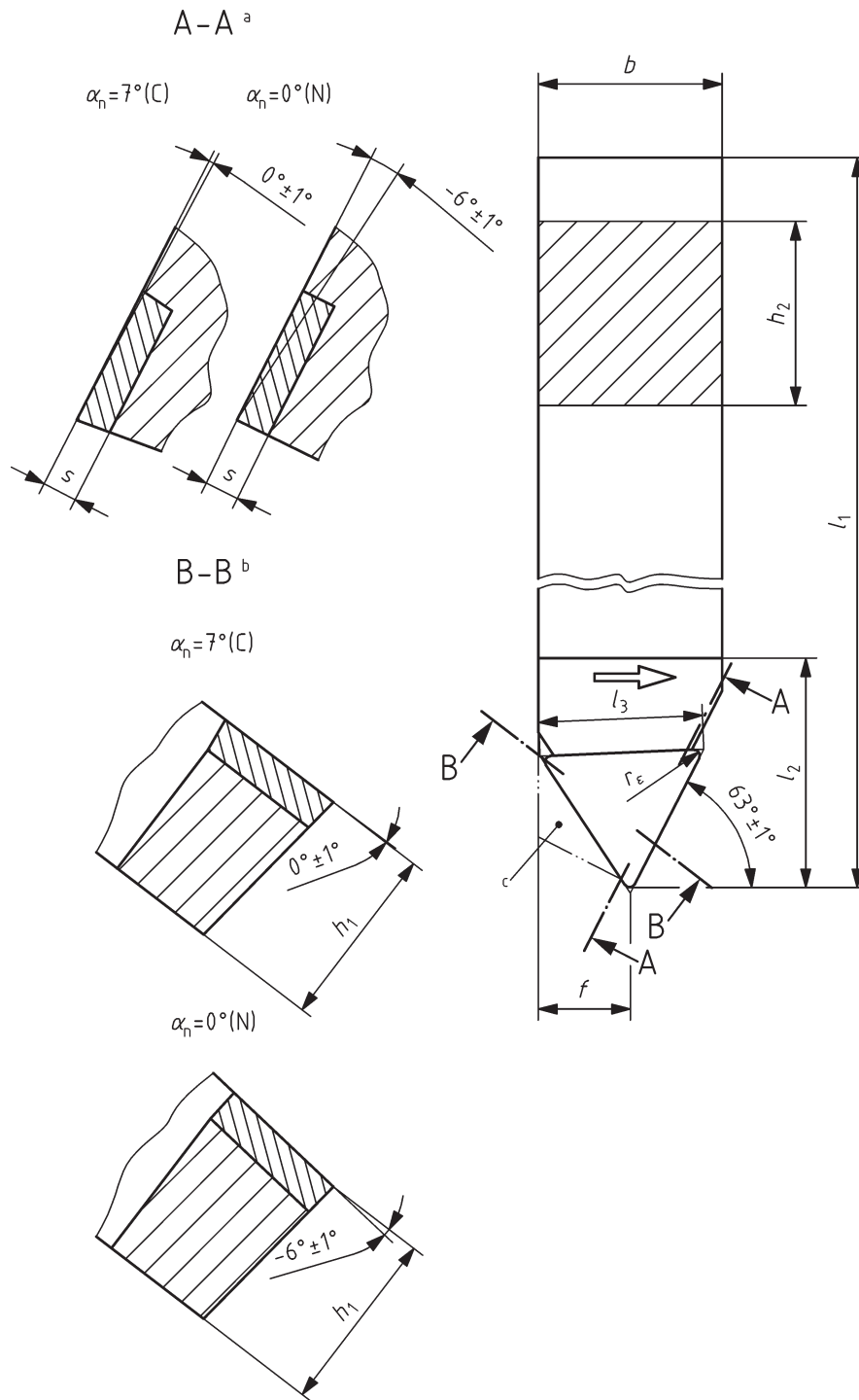

**Key**

- a Inclination angle,  $\lambda_s$ .
- b Rake angle,  $\gamma_0$ .
- c Tool holder style with feed of insert in both directions.

NOTE This figure shows a right-hand tool holder (R); left-hand tool holder (L) laterally reversed.

**Figure 2 — Tool holder style N for triangular indexable insert — T**

**Table 2**

Dimensions in millimetres

Symbol <sup>a</sup>	$h_1$ js13	$b$ h13	$l_3$ ≈	$f$ +0,5 0	$h_2$ h13	$l_1^a$ k16	$l_2$ max.	$s^b$
STNCR 2525 — 16	25	25	16,5	12,5	25	—	32	3,97
STNCL 2525 — 16								4,76
PTNNR 2525 — 16								
PTNNL 2525 — 16								
STNCR 2525 — 22	25	25	22	12,5	25	—	32	4,76
STNCL 2525 — 22								
PTNNR 2525 — 22								
PTNNL 2525 — 22								
STNCR 3225 — 16	32	25	16,5	12,5	32	—	32	3,97
STNCL 3225 — 16								4,76
PTNNR 3225 — 16								
PTNNL 3225 — 16								
STNCR 3225 — 22	32	25	22	12,5	32	—	36	4,76
STNCL 3225 — 22								
PTNNR 3225 — 22								
PTNNL 3225 — 22								
STNCR 4032 — 22	40	32	22	16	40	—	36	4,76
STNCL 4032 — 22								
PTNNR 4032 — 22								
PTNNL 4032 — 22								

<sup>a</sup> For the selection of length,  $l_1$ , the dash can be replaced by the dimensions of ISO 5610-1:2014, Table 2. For letter symbols identifying the tool length, see ISO 5608:2012, Table 6.

<sup>b</sup> Insert thickness without shim, if applicable.

#### 4 Designation

A tool holder in accordance with this part of ISO 5610 shall be designated by the following:

- “Tool holder”;
- a reference to this part of ISO 5610 (i.e. ISO 5610-10);
- type of mounting, in accordance with ISO 5608;
- symbol for indexable insert shape, in accordance with ISO 5608;
- symbol for tool style, in accordance with ISO 5608;
- symbol for the indexable insert normal clearance, in accordance with ISO 5608;
- symbol for hand of tool, in accordance with ISO 5608;
- its height,  $h_1$ , width,  $b$ , and length,  $l_1$  (symbol for tool length in accordance with ISO 5608);
- its cutting edge length,  $l_3$ .

EXAMPLE 1 Tool holder for a horizontally mounted bore-clamped (P) rhombic indexable insert shape D (D), tool holder style N (N), for normal clearance of indexable insert  $\alpha_n = 0^\circ$  (N), right-hand type (R), with height  $h_1 = 40$  mm and width  $b = 32$  mm (4032), length  $l_1 = 170$  mm (P), for cutting edge length  $l_3 = 15,5$  mm (15) is designated as follows:

**Tool holder ISO 5610-10 - PDNNR 4032 P15**

EXAMPLE 2 Tool holder for a horizontally mounted bore-clamped (P) triangular indexable insert shape T (T), tool holder style N (N), for normal clearance of indexable insert  $\alpha_n = 0^\circ$  (N), right-hand type (R), with height  $h_1 = 40$  mm and width  $b = 32$  mm (4032), length  $l_1 = 150$  mm (M), for cutting edge length  $l_3 = 22$  mm (22) is designated as follows:

**Tool holder ISO 5610-10 - PTNNR 4032 M22**

## 5 Material

The material should be steel with a tensile strength of at least 1 200 N/mm<sup>2</sup>.

## 6 Design

### 6.1 Type of mounting

Standard design of tool holders with indexable insert shall be mounted in accordance with [Tables 1](#) and [2](#).

Other types of mounting are at the manufacturer's discretion or upon agreement. The letter symbol in the designation, symbol 1, shall then be replaced by the respective symbol for the chosen or agreed-upon type of mounting in accordance with ISO 5608.

For the modified type of mounting deviating from [Tables 1](#) and [2](#), the relevant indexable insert thickness shall also be considered.

### 6.2 Corner radius, $r_\epsilon$

Tool holders in accordance with this part of ISO 5610 can be equipped with inserts with cutting edge length,  $l_3$ , as specified in [Tables 1](#) and [2](#), and any corner radius,  $r_\epsilon$ .

The values for  $l_1$  given in ISO 5610-1:2014, Table 2, apply to tool holders with inserts having corner radii,  $r_\epsilon$ , in accordance with [Table 3](#).

**Table 3**

Dimensions in millimetres

$l_3$	$r_\epsilon$
7,75	0,4
11,6	0,8
15,5	
16,5	
22	
NOTE The values given for $r_\epsilon$ are nominal values. The accurate values converted from the inch dimensions are 0,397 mm and 0,794 mm.	

For indexable inserts with corner radii,  $r_\epsilon$ , other than those specified in [Table 3](#), the dimensions  $f$  and  $l_1$  shall be determined in accordance with ISO 5610-1.

The tolerances for  $h_1$ ,  $f$ , and  $l_1$  refer to dimensions measured with master indexable insert and master shim, if applicable.



### **6.3 Thickness, $s$ , of indexable insert**

The values for thickness,  $s$ , given in [Tables 1](#) and [2](#), apply to indexable inserts without shim and for the standard design of tool holders.

For tool holders for indexable inserts with thicknesses deviating from the specified values, the thickness shall be indicated when ordering or upon delivery (in the handbook).

## **7 Extent of delivery**

Tool holders shall be delivered complete with clamping device, but without indexable insert(s).

## **8 Marking**

Tool holders shall be marked with the letter symbol and the name or trademark of the manufacturer.

Additional marking is at the manufacturer's discretion or upon agreement.

Deviations in marking may be by mutual agreement.

A reference to this part of ISO 5610, i.e. ISO 5610-10:2014, shall be given on the packaging.

## Bibliography

- [1] ISO 883, *Indexable hardmetal (carbide) inserts with rounded corners, without fixing hole — Dimensions*
- [2] ISO 3002-1, *Basic quantities in cutting and grinding — Part 1: Geometry of the active part of cutting tools — General terms, reference systems, tool and working angles, chip breakers*
- [3] ISO 3364, *Indexable hardmetal (carbide) inserts with rounded corners, with cylindrical fixing hole — Dimensions*
- [4] ISO 6987, *Indexable hard material inserts with rounded corners, with partly cylindrical fixing hole — Dimensions*
- [5] ISO/TS 13399-2, *Cutting tool data representation and exchange — Part 2: Reference dictionary for the cutting items*
- [6] ISO/TS 13399-3, *Cutting tool data representation and exchange — Part 3: Reference dictionary for tool items*

**NATIONAL ANNEX A**  
*(National Foreword)*

**A-1 BIS CERTIFICATION MARKING**

The tool holders with rectangular shank for indexable inserts may also be marked with the Standard Mark.

**A-1.1** The use of the Standard Mark is governed by the provisions of the *Bureau of Indian Standards Act, 2016* and the Rules and Regulations made thereunder. The details of conditions under which the licence for the use of the Standard Mark may be granted to manufacturers or producers may be obtained from the Bureau of Indian Standards.



(Continued from second cover)

In this adopted standard, reference appears to certain International Standards for which Indian Standards also exist. The corresponding Indian Standards, which are to be substituted in their respective places are listed below along with their degree of equivalence for the editions indicated:

<i>International Standard</i>	<i>Corresponding Indian Standard</i>	<i>Degree of Equivalence</i>
ISO 5608 : 2012 Turning and copying tool holders and cartridges for indexable inserts — Designation	IS 14863 : 2018 Turning and copying tool holders and cartridges for indexable inserts — Designation ( <i>first revision</i> )	Identical
ISO 5610-1 : 2014 Tool holders with rectangular shank for indexable inserts — Part 1: General survey, correlation and determination of dimensions	IS 16637 (Part 1) : 2018 Tool holders with rectangular shank for indexable inserts : Part 1 General survey, correlation and determination of dimensions	do

For the purpose of deciding whether a particular requirement of this standard is complied with, the final value, observed or calculated expressing the result of a test or analysis, shall be rounded off in accordance with IS 2 : 1960 'Rules for rounding off numerical values (*revised*)'. The number of significant places retained in the rounded off value should be the same as that of the specified value in this standard.

## Bureau of Indian Standards

BIS is a statutory institution established under the *Bureau of Indian Standards Act, 2016* to promote harmonious development of the activities of standardization, marking and quality certification of goods and attending to connected matters in the country.

### Copyright

BIS has the copyright of all its publications. No part of these publications may be reproduced in any form without the prior permission in writing of BIS. This does not preclude the free use, in course of implementing the standard, of necessary details, such as symbols and sizes, type or grade designations. Enquiries relating to copyright be addressed to the Director (Publications), BIS.

### Review of Indian Standards

Amendments are issued to standards as the need arises on the basis of comments. Standards are also reviewed periodically; a standard along with amendments is reaffirmed when such review indicates that no changes are needed; if the review indicates that changes are needed, it is taken up for revision. Users of Indian Standards should ascertain that they are in possession of the latest amendments or edition by referring to the latest issue of 'BIS Catalogue' and 'Standards: Monthly Additions'.

This Indian Standard has been developed from Doc No.: PGD 32 (10139).

#### Amendments Issued Since Publication

Amendment No.	Date of Issue	Text Affected

#### BUREAU OF INDIAN STANDARDS

##### Headquarters:

Manak Bhavan, 9 Bahadur Shah Zafar Marg, New Delhi 110002

Telephones: 2323 0131, 2323 3375, 2323 9402

Website: [www.bis.gov.in](http://www.bis.gov.in)

##### Regional Offices:

Telephones

Central : Manak Bhavan, 9 Bahadur Shah Zafar Marg  
NEW DELHI 110002

{ 2323 7617  
2323 3841

Eastern : 1/14, C.I.T. Scheme VII M, V.I.P. Road, Kankurgachi  
KOLKATA 700054

{ 2337 8499, 2337 8561  
2337 8626, 2337 9120

Northern : Plot No. 4-A, Sector 27-B, Madhya Marg, CHANDIGARH 160019

{ 26 50206  
265 0290

Southern : C.I.T. Campus, IV Cross Road, CHENNAI 600113

{ 2254 1216, 2254 1442  
2254 2519, 2254 2315

Western : Manakalaya, E9 MIDC, Marol, Andheri (East)  
MUMBAI 400093

{ 2832 9295, 2832 7858  
2832 7891, 2832 7892

**Branches** : AHMEDABAD. BENGALURU. BHOPAL. BHUBANESWAR. COIMBATORE.  
DEHRADUN. DURGAPUR. FARIDABAD. GHAZIABAD. GUWAHATI.  
HYDERABAD. JAIPUR. JAMMU. JAMSHEDPUR. KOCHI. LUCKNOW. NAGPUR.  
PARWANOO. PATNA. PUNE. RAIPUR. RAJKOT. VISAKHAPATNAM.

Published by BIS, New Delhi