हल्की कन्वेयर बेल्ट — विद्युत
प्रतिरोध का मापना

Light Conveyor Belts —
Determination of Electrical
Resistances

ICS 53.040.10

© BIS 2017



भारतीय मानक ब्यूरो
BUREAU OF INDIAN STANDARDS
मानक भवन, 9 बहादुरशाह ज़फर मार्ग, नई दिल्ली-110002
MANAK BHAVAN, 9 BAHADUR SHAH ZAFAR MARG
NEW DELHI-110002
www.bis.org.in www.standardsbis.in

NATIONAL FOREWORD

This Indian Standard which is identical with ISO 21178 : 2013 'Light conveyor belts — Determination of electrical resistances' issued by the International Organization for Standardization (ISO) was adopted by the Bureau of Indian Standards on the recommendation of the Transmission Devices Sectional Committee and approval of the Production and General Engineering Division Council.

The text of ISO Standard has been approved as suitable for publication as an Indian Standard without deviations. Certain terminology and conventions are, however, not identical to those used in Indian Standards. Attention is particularly drawn to the following:

- a) Wherever the words 'International Standard' appear referring to this standard, they should be read as 'Indian Standard'.
- b) Comma (,) has been used as a decimal marker while in Indian Standards, the current practice is to use a point (.) as the decimal marker.

The technical committee has reviewed the provisions of the following International Standard referred in this adopted standard and has decided that it is acceptable for use in conjunction with this standard:

International Standard

Title

ISO 18573

Conveyors belts — Test atmosphere and conditioning periods

Indian Standard

**LIGHT CONVEYOR BELTS — DETERMINATION OF
 ELECTRICAL RESISTANCES**

1 Scope

This International Standard specifies test methods for determining the electrical resistances of light conveyor belts according to ISO 21183-1. The resistances are surface resistance, volume resistance perpendicular to the belt plane, and longitudinal and transverse volume resistance parallel to the belt plane. This International Standard also specifies two test methods for determining the surface resistivity and the volume resistivity.

2 Normative references

The following documents, in whole or in part, are normatively referenced in this document and are indispensable to its application. For undated references, the latest edition of the referenced document (including any amendments) applies.

ISO 18573, *Conveyor belts — Test atmospheres and conditioning periods*

3 Symbols

Symbol	Quantity	Unit
R_{0A}	Electrical surface resistance, method A	Ω
R_{0B}	Electrical surface resistance, method B	Ω
R_{0G}	Electrical surface resistance for the determination of ρ_s	Ω
R_D	Electrical volume resistance perpendicular to the plane of the belt	Ω
R_{Di}	Electrical volume resistance in longitudinal and transverse direction parallel to the plane of the belt	Ω
ρ_s	Electrical surface resistivity	Ω
ρ_D	Electrical volume resistivity	$\Omega \cdot \text{cm}$
$d_{1/2/3}$	Diameter of electrode	cm
d_m	Middle of the gap diameter	cm
g	Width of the gap	cm
A	Surface of the electrode	cm^2
h	Thickness of test piece	cm

NOTE The SI unit of surface resistivity, ρ_s , is the ohm (Ω). In practice, this is sometimes referred to as "ohm/square" or " Ω/sq " or " Ω/\square ". The size of the square is immaterial.

4 Electrical surface resistances

4.1 Method A: measurement of surface resistance R_{OA} **omni-directionally**

4.1.1 Applicability

This method is applicable to belts which are electrically two-dimensionally isotropic in the plane of the belt.

4.1.2 Principle

An electric current of specified voltage is passed via electrodes through a suitably prepared test piece taken from the belt.

4.1.3 Apparatus

4.1.3.1 Sheet of insulating material, a little larger than the test piece

4.1.3.2 Two cylindrical and coaxial brass electrodes, the base of one being circular and that of the other annular. The dimensions and masses are given in [Figure 2](#). The bases of these electrodes shall be machined flat and polished.

4.1.3.3 Flexible insulated wire, connected to each electrode.

4.1.3.4 Ohmmeter, having a measuring range up to $10^{10} \Omega$ and accurate to within $\pm 5\%$.

4.1.3.5 Source of direct current, adjustable up to 500 V, and not permitting a current greater than 10 mA.

NOTE The source of current can be either an accumulator or a rectified, stabilized a.c. power supply.

4.1.4 Test piece

4.1.4.1 Material

Test piece material shall be new, unused ("virgin"), but shall not be tested sooner than five days after manufacture. It shall be free from contamination and superficial damage.

4.1.4.2 Dimensions

The test pieces shall be square, 300 mm \times 300 mm minimum, and shall be cut from the full thickness of the belt.

4.1.4.3 Number

Three test pieces shall be taken. One test piece shall be taken from the middle of the belt, the other two test pieces shall be taken 100 mm from each of the belt edges.

4.1.4.4 Cleaning

If necessary, clean both surfaces of the test pieces by rubbing with fuller's earth (hydrated magnesium-aluminium silicate), for example, using a clean cloth. After cleaning away all traces of the powder, wipe the surface with a clean cloth moistened with distilled water and then dry with a clean cloth.

4.1.4.5 Conditioning

Before testing, condition the test pieces in accordance with ISO 18573, Atmosphere B, for 24 h, except that, if the light conveyor belt consists of materials with a high absorption of moisture, e.g. cotton or polyamide, condition the test piece for 48 h.

4.1.4.6 Preparation

Prepare the test pieces in the following manner after conditioning according to [4.1.4.5](#).

To ensure good contact between electrodes and test piece a contact agent shall be used. The electrical surface resistivity of the contact agent shall not be higher than $10^4 \Omega$. For checking this value, use the same electrode arrangement as described in [Clause 5](#).

NOTE A jelly having the following composition is suitable:

- anhydrous polyethylene glycol of molecular mass 600: 800 mg/g (mass fraction);
- water: 200 mg/g (mass fraction);
- potassium chloride: 10 mg/g (mass fraction);
- soft soap (pharmaceutical quality): 1 mg/g (mass fraction).

If the surface of the test piece is flat, paint the contact agent onto the bottom surface of the cleaned electrodes. If the surface of the test piece is textured, paint two areas of the test piece as shown in [Figure 1](#). Take care to ensure the accuracy of the dimensions of the painted areas, although the symmetry of the centre is not critical. Carry out the test immediately after painting. If silver lacquer is used as the contact agent, carry out the test after evaporating the solvent.

4.1.5 Procedure

Measure the temperature and relative humidity in the test room.

Place the test piece on the sheet of insulating material, with the test surface upwards.

Paint the test piece or bottom surface of the cleaned electrodes with contact agent and let the solvent evaporate, if necessary.

If necessary, clean the electrodes and place them on the test piece.

Apply the test voltage to the electrodes, starting with a low voltage to protect very fine antistatic layers against damage.

Read the value of the electrical resistance 1 min after applying the test voltage.

Dimensions in millimetres

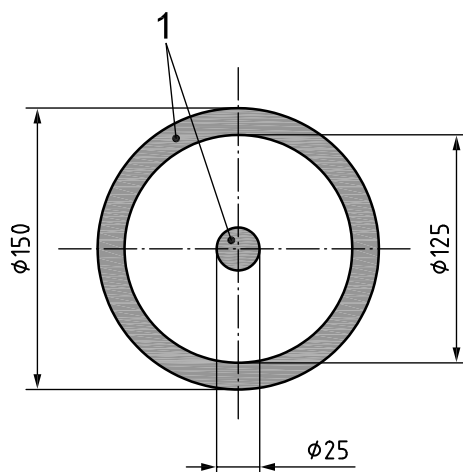

Key

- 1 contact agent

Figure 1 — Design to be painted on the test piece

Dimensions in millimetres

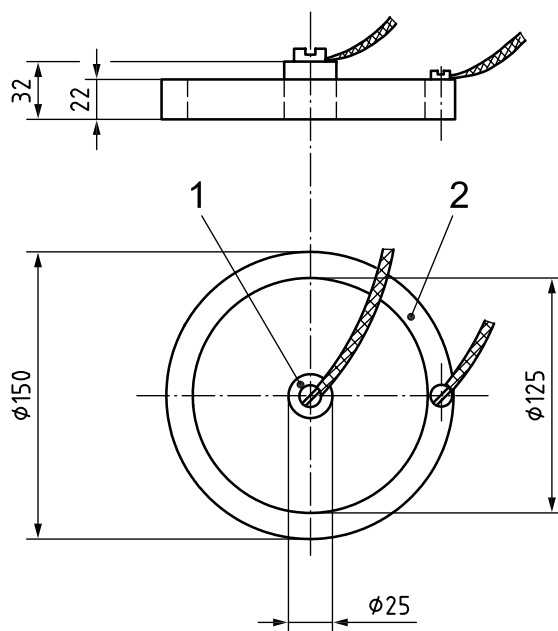

Key

- 1 min. mass 115 g
- 2 min. mass 900 g

Figure 2 — Electrodes

4.1.6 Expression of results

For each surface of the belt subjected to test, record the electrical resistance, in ohms, measured for each test piece, and calculate the mean of the values recorded for that surface for the three test pieces.

Record the electrical resistance for the two surfaces of the belt separately.

4.1.7 Test report

The test report shall include the following information:

- a) complete designation of the tested light conveyor belt material and the manufacturing date;
- b) reference to this International Standard, i.e. ISO 21178;
- c) test room temperature and relative humidity;
- d) conditioning period;
- e) contact agent applied;
- f) voltage applied to the electrodes;
- g) results of the tests;
- h) date of test;
- i) any deviations from the standard test.

4.2 Method B: measurement of surface resistance R_{OB} in longitudinal and transverse direction

4.2.1 Applicability

This method is applicable to belts which have electrically varying properties in the plane of the belt, especially those where fabrics have conducting threads in the longitudinal direction which may be exposed on the belt surface.

4.2.2 Principle

An electric current is passed via electrodes clamped in a suitable arrangement to the surface of a test piece of the belt material.

4.2.3 Apparatus (see [Figure 3](#))

4.2.3.1 Earthed screen plate

4.2.3.2 Bottom plate, made of insulating material, such as polymethylmethacrylate, polytetrafluoroethylene or similar, having dimensions 600 mm × 200 mm × 20 mm.

4.2.3.3 Brass electrodes, with connection points for the ohmmeter connecting cables, having a contact area of 100 mm × 10 mm.

4.2.3.4 Electrode holders

4.2.3.5 Ohmmeter, having a measuring range up to $10^{10} \Omega$ and accurate to within $\pm 5 \%$.

4.2.3.6 Source of direct current, adjustable up to 500 V, and not permitting a current greater than 10 mA.

NOTE The source current can be either an accumulator or a rectified, stabilized a.c. power supply.

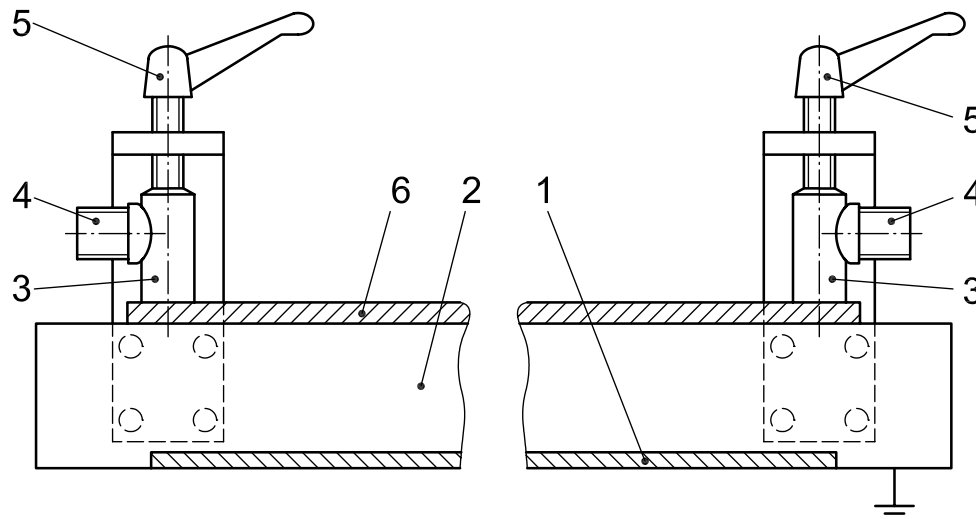

Key

- 1 screen plate, earthed
- 2 bottom plate
- 3 electrodes
- 4 connection points
- 5 electrode holder
- 6 test piece

Figure 3 — Test arrangement for measurement of electrical surface resistance R_{OB}

4.2.4 Test piece

4.2.4.1 Material

Test piece material shall be new, unused (“virgin”), but shall not be tested sooner than five days after manufacture. It shall be free of any kind of contamination or superficial damage.

4.2.4.2 Dimensions

The test pieces, 500 mm long × 100 mm wide, shall be cut from the full thickness of the light conveyor belt in the longitudinal or transverse direction.

4.2.4.3 Number

Three test pieces shall be taken. One test piece shall be taken from the middle of the belt, the other two test pieces shall be taken 100 mm from each of the belt edges.

4.2.4.4 Conditioning

Condition the test pieces in accordance with [4.1.4.5](#).

4.2.4.5 Preparation

To ensure good contact between electrodes and test piece a suitable contact agent shall be used. Its electrical surface resistivity shall not be higher than $10^4 \Omega$ (see [4.1.4.6](#)).

4.2.5 Procedure

Measure the temperature and relative humidity in the test room.

Place the test piece on the insulating plate so that the warp is exactly at right angles to the long axes of the electrodes.

Place the electrodes on top of the test piece and clamp them in position.

Apply the test voltage to the electrodes starting with a low voltage to protect fine conducting layers against damage.

Read the value of the electrical resistance 1 min after applying the test voltage.

4.2.6 Expression of results

See [4.1.6](#).

4.2.7 Test report

See [4.1.7](#).

5 Electrical surface resistivity ρ_s

5.1 General

This electrical surface resistivity is calculated from the electrical surface resistance R_{OG} , determined with a different electrode arrangement to that used in [4.1](#). This method is applicable to the same types of belt to which the method described in [4.1](#) applies.

NOTE 1 See [Annex A](#).

NOTE 2 The unit is the ohm (Ω) but is also written Ω/sq or Ω/\square (see [Clause 3](#), footnote 1).

5.2 Principle

An electric current of specified voltage is passed via electrodes through a suitably prepared test piece taken from the belt.

5.3 Apparatus

5.3.1 Three electrodes, see [Figures 4](#) and [5](#), having the following diameters: $d_1 = 50$ mm, $d_2 = 60$ mm, $d_3 = 80$ mm, and $d_m = [(d_1 + d_2)/2]$ mm.

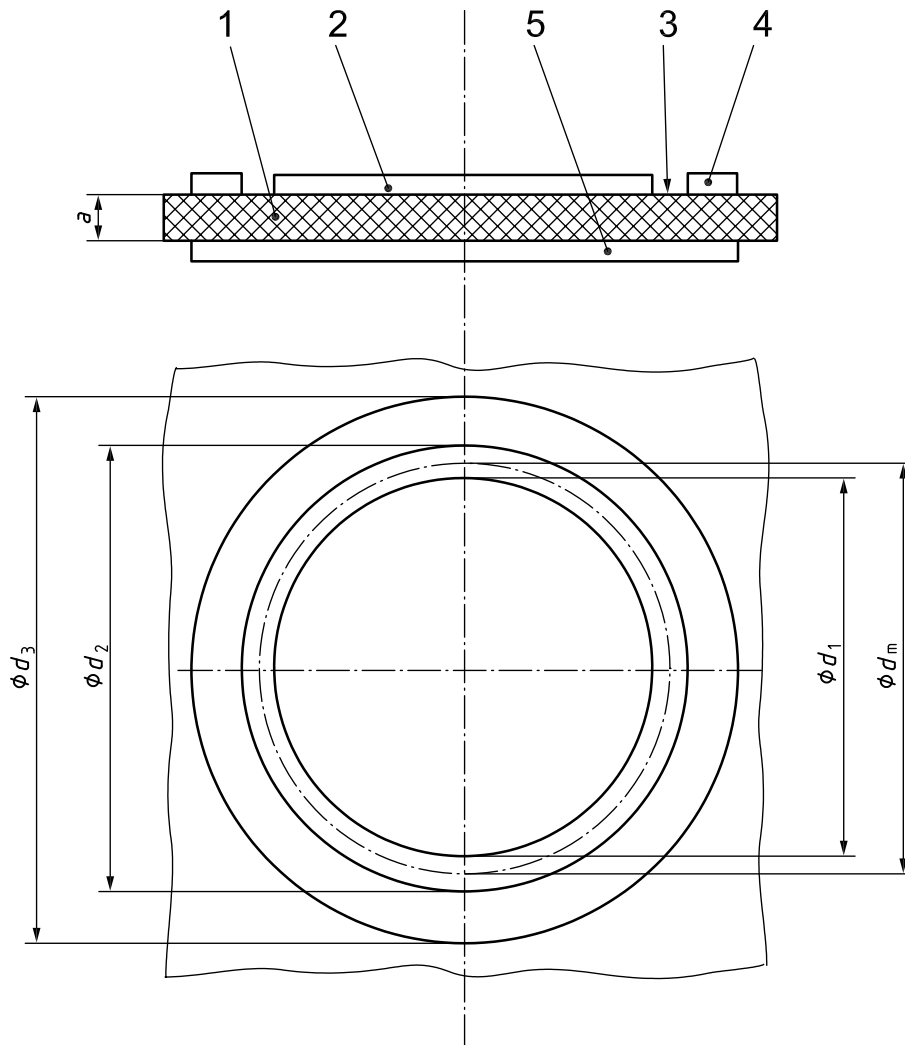

Key

- 1 test piece, thickness = a
- 2 electrode 1
- 3 measuring area
- 4 electrode 2
- 5 electrode 3

Figure 4 — Diameter of electrodes for measuring electrical surface resistance R_{OG}

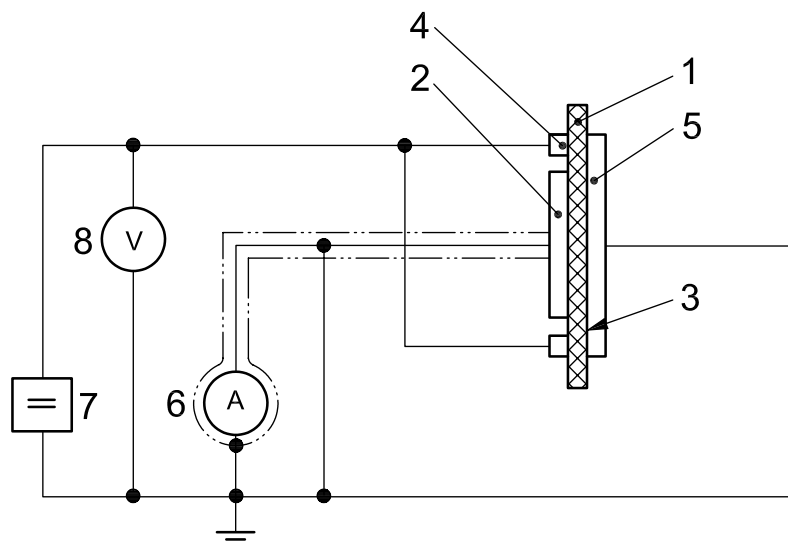

Key

- 1 test piece
- 2 electrode 1
- 3 measuring area
- 4 electrode 2
- 5 electrode 3
- 6 ammeter
- 7 d.c. source
- 8 voltmeter

Figure 5 — Electrodes and general arrangement of electrodes for measuring electrical surface resistance R_{OG} of light conveyor belts

5.3.2 Ohmmeter, having a measuring range up to $10^{10} \Omega$ and accurate to within $\pm 5 \%$.

5.3.3 Source of direct current, adjustable up to 500 V, and not permitting a current greater than 10 mA.

NOTE The source current can be either an accumulator or a rectified, stabilized a.c. power supply.

5.4 Preparation and preservation of test pieces prior to testing

The test pieces shall be in accordance with 4.1.4, except that the dimensions shall be 120 mm \times 120 mm.

5.5 Procedure

Carry out the procedure in accordance with 4.1.5.

5.6 Expression of results

For each surface of the belt tested, record the electrical resistance R_{OG} , in ohms. Then, calculate the surface resistivity, as follows.

$$\rho_s = \frac{d_m \pi}{g} R_{OG} \Omega$$

where

$$d_m = \frac{d_1 + d_2}{2} \text{ cm}$$

$$g = \frac{d_2 - d_1}{2} \text{ cm}$$

For each surface of the belt tested, calculate the surface resistivity, in ohms, for each test piece, and calculate the arithmetic mean of the values for that surface for the three test pieces.

5.7 Test report

See [4.1.7](#).

6 Electrical volume resistances

6.1 Volume resistance R_D perpendicular to plane of belt

6.1.1 Principle

The top and bottom sides of a test piece, cut from the full thickness of the light conveyor belt, are connected to electrodes.

The electrodes are connected to a direct voltage source and the volume resistance is determined either by measuring the voltage and the resulting current and subsequent calculation, or by direct measurement of the resistance.

6.1.2 Apparatus

6.1.2.1 General apparatus

6.1.2.1.1 Three brass electrodes (see [Figure 6](#)), with contact surfaces machined flat and polished, as follows.

6.1.2.1.1.1 Measuring electrode, circular.

6.1.2.1.1.2 Guarding electrode, annular.

6.1.2.1.1.3 Counter electrode, of any shape provided that its area is greater than the test piece.

6.1.2.1.2 Flexible and insulated wire, connected to each electrode.

6.1.2.2 Apparatus for current-voltage measuring method (see [Figure 7](#))

6.1.2.2.1 Voltage source, steady d.c. $500 \text{ V} \pm 5 \text{ V}$.

6.1.2.2.2 Voltmeter with maximum error of $\pm 2\%$.

6.1.2.2.3 Ammeter or **galvanometer** with precision shunt and maximum error of $\pm 2\%$.

6.1.2.3 Apparatus for direct-reading instrument method (see [Figure 8](#))

6.1.2.3.1 Ohmmeter, having a measuring range up to $10^{10} \Omega$ and accurate to within $\pm 5\%$. The instrument shall be calibrated in the range 100 V to 500 V d.c., current $I_{\max} = 10$ mA.

6.1.3 Test piece

6.1.3.1 Material

Test piece material shall be new, unused (“virgin”), but shall not be tested sooner than five days after manufacture. It shall be free from contamination and superficial damage.

6.1.3.2 Dimensions

The test pieces shall be square, 120 mm \times 120 mm, and shall be cut from the full thickness of the belt.

6.1.3.3 Number

Three test pieces shall be taken. One test piece shall be taken from the middle of the belt, the other two test pieces shall be taken 100 mm from each of the belt edges.

6.1.3.4 Cleaning

If necessary, clean both surfaces of the test piece by rubbing with fuller’s earth (hydrated magnesium-aluminium silicate), for example, using a clean cloth. After cleaning away all traces of the powder, wipe the surface with a clean cloth moistened with distilled water and then dry with a clean cloth.

6.1.3.5 Conditioning

Before testing, condition the test pieces in accordance with ISO 18573, Atmosphere B, for 24 h, except that, if the light conveyor belt consists of materials with a high absorption of moisture, e.g. cotton or polyamide, condition the test piece for 48 h.

6.1.4 Procedure

Measure the temperature and relative humidity in the test room.

Bring the test piece into contact with the electrodes.

If using the direct-reading method, do not use guard electrode (illustrated as item 5 in [Figure 7](#)).

The contact areas may be painted with a contact agent, if necessary.

Connect cables as per the arrangement and method (see [Figures 6](#) and [7](#)).

Apply the test voltage for 60 s.

Measure and record the volume resistance, R_D .

If the resulting volume resistance R_D is $> 10^8 \Omega$, repeat the measurement with the guard electrode fitted (illustrated as item 5 in [Figure 7](#)).

If the measured resistance R_D is $> 10^{10} \Omega$, and a mains supply was used, remove it and repeat the measurement with an off-the-line d.c. source. Take the result of this measurement as final.

6.1.5 Expression of results

Express the results as the arithmetic mean value of the measurements on the three test pieces.

NOTE Normally, the range of values is $\pm 10\%$ to $\pm 20\%$.

6.1.6 Test report

The test report shall include the following information:

- a) complete designation of the tested light conveyor belt material and the manufacturing date;
- b) reference to this International Standard;
- c) test room temperature and relative humidity;
- d) conditioning period;
- e) contact agent, if applied;
- f) method of measurement (current-voltage or direct reading);
- g) voltage fed to the electrodes;
- h) time that voltage was applied;
- i) measured values of the appropriate resistances, in ohms;
- j) date of test;
- k) any deviations from the standard test.

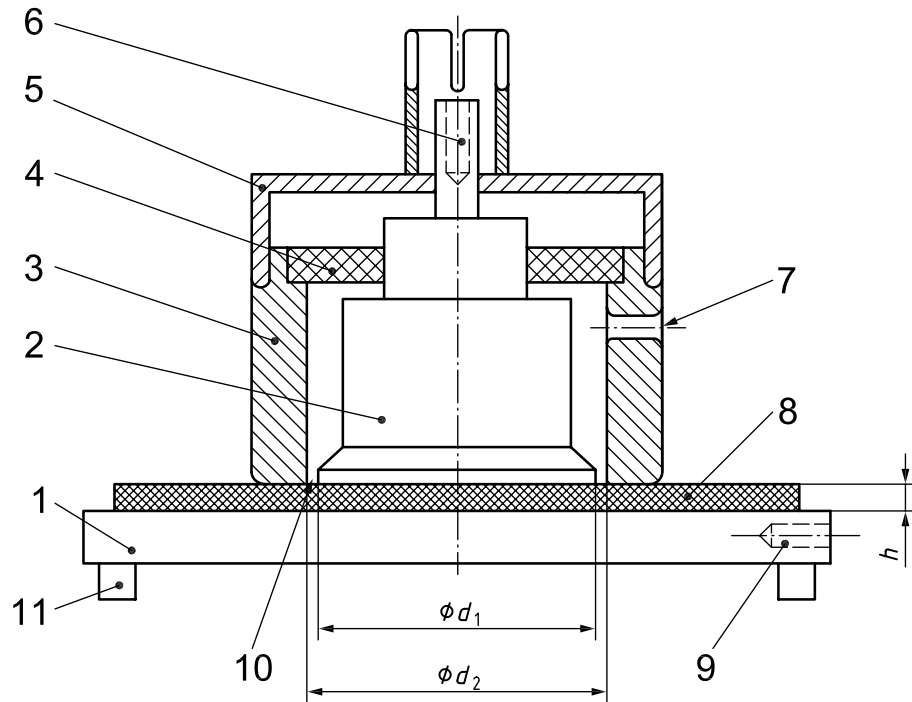

Key

$d_1 = 50$ mm

$d_2 = 60$ mm

- 1 electrode 3 (counter electrode, unguarded electrode)
- 2 electrode 1 (measuring electrode, guarded electrode)
- 3 electrode 2 (guard electrode, guard ring)
- 4 isolating and guide piece
- 5 shielding cap
- 6 positive pole connector for ohmmeter or ammeter
- 7 connector for earthing
- 8 test piece
- 9 negative pole connector for ohmmeter or ammeter
- 10 guarding gap
- 11 isolating stands

Figure 6 — Circular disk electrode with guard ring for measurement of electrical volume resistance R_D of light conveyor belts (design example)

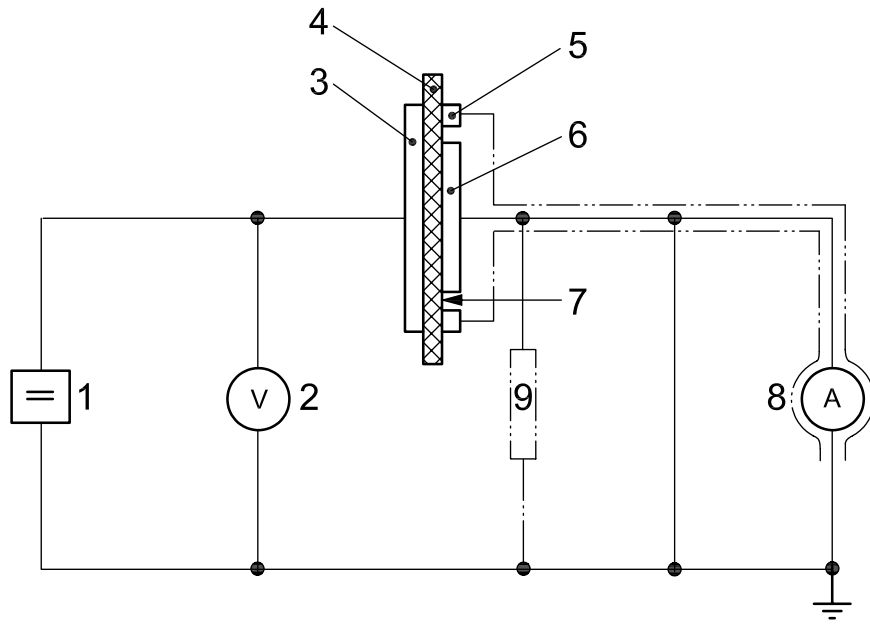

Key

- 1 d.c. voltage source
- 2 voltmeter
- 3 electrode 3 (counter electrode, unguarded electrode)
- 4 test piece
- 5 electrode 2 (guard electrode, guard ring)
- 6 electrode 1 (measuring electrode, guarded electrode)
- 7 guarding gap
- 8 ammeter
- 9 precision shunt, signifies the guarding gap resistance (minimum $100 \times$ input resistance of ammeter)

Figure 7 — Arrangement for measuring electrical volume resistance R_D of light conveyor belts using current-voltage measuring method

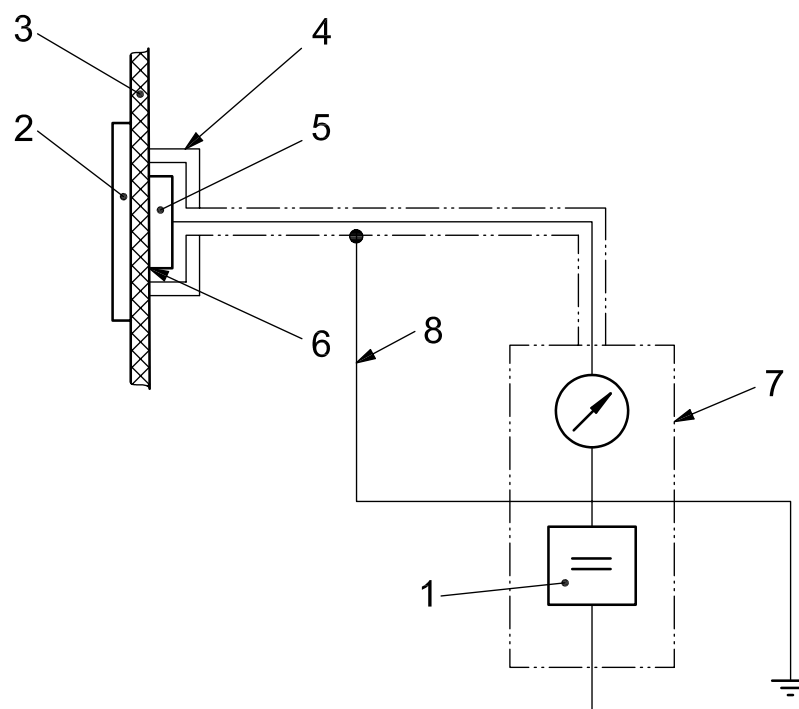

Key

- 1 integrated d.c. voltage source
- 2 electrode 3 (counter electrode, unguarded electrode)
- 3 test piece
- 4 electrode 2 (guard electrode, guard ring)
- 5 electrode 1 (measuring electrode, guarded electrode)
- 6 guarding gap
- 7 integrated ohmmeter
- 8 parasite current

Figure 8 — Arrangement for measuring electrical volume resistance, R_D , of light conveyor belts using direct reading instrument method

6.2 Volume resistance, R_{Di} , in longitudinal and transverse direction parallel to plane of belt

6.2.1 Principle

An electric current is passed via electrodes through a suitably prepared test piece taken from the conveyor belt material.

6.2.2 Apparatus (see [Figure 9](#))

6.2.2.1 Screen plate (counter plate), earthed.

6.2.2.2 Bottom plate, made of insulating material such as polymethylmethacrylate, polytetrafluoroethylene or similar, having dimensions 600 mm × 200 mm × 20 mm.

6.2.2.3 Brass electrodes with connection points for the ohmmeter connecting cables, having a contact area of 50 mm × 10 mm.

6.2.2.4 Electrode holders.

6.2.2.5 **Ohmmeter**, having a measuring range up to $10^{10} \Omega$ and accurate to within $\pm 5 \%$.

6.2.2.6 **Source of direct current**, adjustable up to 500 V, and not permitting a current greater than 10 mA.

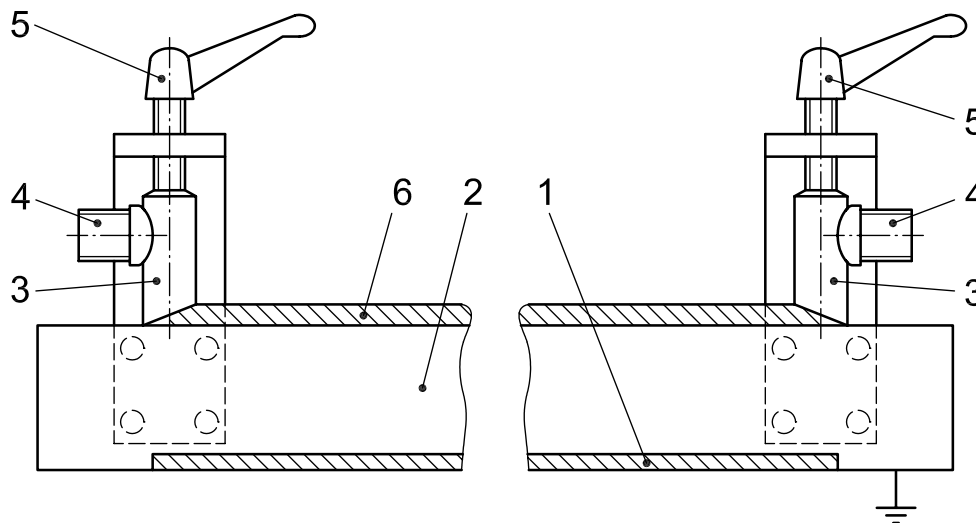

Key

- 1 screen plate, earthed
- 2 bottom plate
- 3 electrodes
- 4 connection points
- 5 electrode holder
- 6 test piece

Figure 9 — Test arrangement for measuring electrical volume resistance, R_{Di} , in longitudinal and transverse direction parallel to plane of belt

6.2.3 Test piece

6.2.3.1 Material

Test piece material shall be new, unused (“virgin”), but shall not be tested sooner than five days after manufacture.

It shall be free from contamination and superficial damage.

6.2.3.2 Dimensions

The test pieces, 500 mm long \times 50 mm wide, shall be cut from the full thickness of the light conveyor belt in the longitudinal or transverse direction.

6.2.3.3 Number

Three test pieces shall be taken. One test piece shall be taken from the middle of the belt, the other two test pieces shall be taken 100 mm from each of the belt edges.

6.2.3.4 Preparation

The ends of the test piece shall be slanted (e.g. wedge-shaped) in such a way that the conductive layer will make a good contact with the electrodes.

For materials that comprise more than one antistatic layer, if only one layer is to be tested, the other layers shall be removed.

The slanted ends of the test piece shall be painted with a contact agent having an electrical surface resistivity not exceeding $10^4 \Omega$ directly before testing.

NOTE A jelly as described in [4.1.4.6](#) is suitable.

6.2.3.5 Conditioning

Before testing, condition the test pieces in accordance with ISO 18573, Atmosphere B, for 24 h, except that, if the light conveyor belt consists of materials with a high absorption of moisture, e.g. cotton or polyamide, condition the test piece for 48 h.

6.2.4 Procedure

Measure the temperature and relative humidity in the test room.

Place the test piece on the bottom plate of insulating material.

Paint the slanted ends of the test piece with the contact agent.

Put the electrodes on the slanted ends of the test piece and fasten them with the screws of the holder.

Apply the test voltage to the electrodes starting with a low voltage to protect very fine antistatic layers against damage.

Read the value of the electrical resistance 1 min after applying the test voltage.

6.2.5 Expression of results

Record the electrical resistance, in ohms, measured for each test piece, and calculate the arithmetic mean of the values recorded for the three test pieces.

6.2.6 Test report

The test report shall include the following information:

- a) complete designation of tested light conveyor belt material and manufacturing date;
- b) reference to this International Standard, i.e. ISO 21178;
- c) test room temperature and relative humidity;
- d) conditioning period;
- e) contact agent applied;
- f) voltage fed to the electrodes;
- g) results of the tests, including the individual values;
- h) date of test;
- i) any deviations from the standard test.

7 Electrical volume resistivity ρ_D

7.1 Procedure

Determine the volume resistivity, ρ_D , by calculation using the following formula:

$$\rho_D = \frac{R_D \times A}{h} \Omega \cdot \text{cm}$$

where

R_D is the volume resistance, expressed in ohms (see [6.1.5](#));

A is the nominal surface area of the measuring electrode, expressed in square centimetres:

— for test pieces having a thickness over 0,1 cm = 20,0 cm²,

— for test pieces having a thickness up to 0,1 cm = 19,2 cm²;

h is the thickness of test piece, expressed in centimetres.

NOTE See [Annex A](#).

7.2 Expression of results

Record the volume resistivity, in ohm centimetres, measured for each test piece, and calculate the arithmetic mean of the values recorded for the three test pieces.

7.3 Test report

The test report shall include the following information.

Report the test results in accordance with 6.1.6 [a) to k)] except for 6.1.6 i), which becomes:

“i) calculated values of volume resistivity, ρ_D , in ohm centimetres”.

Annex A (informative)

Comparative values for electrical resistances

The values obtained using the methods described in [Clauses 5](#) and [7](#) are comparable to those obtained using ASTM D 257:2007.

Bibliography

- [1] ISO 21183-1, *Light conveyor belts — Part 1: Principal characteristics and applications*
- [2] ASTM D 257:2007, *Standard test methods for DC resistance or conductance of insulating materials*

Bureau of Indian Standards

BIS is a statutory institution established under the *Bureau of Indian Standards Act, 1986* to promote harmonious development of the activities of standardization, marking and quality certification of goods and attending to connected matters in the country.

Copyright

BIS has the copyright of all its publications. No part of these publications may be reproduced in any form without the prior permission in writing of BIS. This does not preclude the free use, in the course of implementing the standard, of necessary details, such as symbols and sizes, type or grade designations. Enquiries relating to copyright be addressed to the Director (Publications), BIS.

Review of Indian Standards

Amendments are issued to standards as the need arises on the basis of comments. Standards are also reviewed periodically; a standard along with amendments is reaffirmed when such review indicates that no changes are needed; if the review indicates that changes are needed, it is taken up for revision. Users of Indian Standards should ascertain that they are in possession of the latest amendments or edition by referring to the latest issue of 'BIS Catalogue' and 'Standards : Monthly Additions'.

This Indian Standard has been developed from Doc No.: PGD 33 (1425).

Amendments Issued Since Publication

Amend No.	Date of Issue	Text Affected

BUREAU OF INDIAN STANDARDS

Headquarters:

Manak Bhavan, 9 Bahadur Shah Zafar Marg, New Delhi 110002

Telephones : 2323 0131, 2323 3375, 2323 9402

Website: www.bis.org.in

Regional Offices:

Central : Manak Bhavan, 9 Bahadur Shah Zafar Marg
NEW DELHI 110002

Telephones

{ 2323 7617
2323 3841

Eastern : 1/14 C.I.T. Scheme VII M, V. I. P. Road, Kankurgachi
KOLKATA 700054

{ 2337 8499, 2337 8561
2337 8626, 2337 9120

Northern : Plot No. 4-A, Sector 27-B, Madhya Marg, CHANDIGARH 160019

{ 26 50206
265 0290

Southern : C.I.T. Campus, IV Cross Road, CHENNAI 600113

{ 2254 1216, 2254 1442
2254 2519, 2254 2315

Western : Manakalaya, E9 MIDC, Marol, Andheri (East)
MUMBAI 400093

{ 2832 9295, 2832 7858
2832 7891, 2832 7892

Branches: AHMEDABAD. BENGALURU. BHOPAL. BHUBANESHWAR. COIMBATORE. DEHRADUN. DURGAPUR. FARIDABAD. GHAZIABAD. GUWAHATI. HYDERABAD. JAIPUR. JAMSHEDPUR. KOCHI. LUCKNOW. NAGPUR. PARWANOO. PATNA. PUNE. RAIPUR. RAJKOT. VISAKHAPATNAM.