सिगरेट और फ़िल्टर रॉड —
सांकेतिक व्यास ज्ञात करना —
गैर सम्पर्क प्रकाशिक मापन उपकरणों के
प्रयोग की पद्धति
(पहला पुनरीक्षण)

**Cigarettes and Filter Rods —
Determination of Nominal Diameter —
Method Using a Non-contact
Optical Measuring Apparatus
(First Revision)**

ICS 65.160

© BIS 2018



भारतीय मानक ब्यूरो

BUREAU OF INDIAN STANDARDS

मानक भवन, 9 बहादुरशाह ज़फर मार्ग, नई दिल्ली-110002

MANAK BHAVAN, 9 BAHADUR SHAH ZAFAR MARG

NEW DELHI-110002

www.bis.gov.in www.standardsbis.in

NATIONAL FOREWORD

This Indian Standard (First Revision) which is identical with ISO 2971 : 2013 ‘Cigarettes and filter rods — Determination of nominal diameter — Method using a non-contact optical measuring apparatus’ issued by the International Organization for Standardization (ISO) was adopted by the Bureau of Indian Standards on the recommendation of the Tobacco and Tobacco Products Sectional Committee and approval of the Food and Agriculture Division Council.

This standard was first published in 2008 adopting ISO 2971 : 1998 ‘Cigarettes and filter rods — Determination of nominal diameter — Method using a laser beam measuring apparatus’ under dual numbering system. This revision has been undertaken to align with the latest version of ISO 2971 after incorporation of technical changes.

The text of ISO Standard has been approved as suitable for publication as an Indian Standard without deviations. Certain conventions are however not identical to those used in Indian Standards. Attention is particularly drawn to the following:

- a) Wherever the words ‘International Standard’ appear referring to this standard, they should be read as ‘Indian Standard’.
- b) Comma (,) has been used as a decimal marker while in Indian Standards, the current practice is to use a point (.) as the decimal marker.

In this adopted standard, reference appears to certain International Standards for which Indian Standards also exist. The corresponding Indian Standards, which are to be substituted in their places, are listed below along with their degree of equivalence for the editions indicated:

<i>International Standard</i>	<i>Corresponding Indian Standard</i>	<i>Degree of Equivalence</i>
ISO 3402 Tobacco and tobacco products — Atmosphere for conditioning and testing	IS 16121 : 2013 Tobacco and tobacco products — Atmosphere for conditioning and testing	Identical with ISO 3402 : 1999
ISO 5725-2 : 1994 Accuracy (trueness and precision) of measurement methods and results — Part 2: Basic method for the determination of repeatability and reproducibility of a standard measurement method	IS 15393 (Part 2) : 2003 Accuracy (trueness and precision) of measurement methods and results : Part 2 Basic method for the determination of repeatability and reproducibility of a standard measurement method	Identical

In reporting the result of a test or analysis made in accordance with this standard, is to be rounded off, it shall be done in accordance with IS 2 : 1960 ‘Rules for rounding off numerical values (*revised*)’.

Indian Standard

CIGARETTES AND FILTER RODS —
DETERMINATION OF NOMINAL DIAMETER —
METHOD USING A NON-CONTACT
OPTICAL MEASURING APPARATUS

(*First Revision*)

1 Scope

This International Standard specifies a non contact, optical method of gauging for determination of the mean, minimum and maximum diameters and the ovality (or roundness) of rod-shaped objects with a nominally circular or oval cross section that is convex curvilinear. The method is applicable, in particular, to cigarettes and filter rods.

NOTE 1 Non-contact measurement techniques are discussed in [Annex D](#).

NOTE 2 Alternative contact or pneumatic methods may be used but should be considered as secondary methods and do not come within the scope of the standard. These alternative measurement techniques are discussed in [Annex E](#).

2 Normative references

The following documents, in whole or in part, are normatively referenced in this document and are indispensable for its application. For dated references, only the edition cited applies. For undated references, the latest edition of the referenced document (including any amendments) applies.

ISO 3402, *Tobacco and tobacco products — Atmosphere for conditioning and testing*

ISO 5725-2:1994, *Accuracy (trueness and precision) of measurement methods and results — Part 2: Basic method for the determination of repeatability and reproducibility of a standard measurement method*

3 Terms and definitions

For the purposes of this International Standard, the following terms and definitions apply.

3.1

diameter

arithmetic mean value of n apparent diameters measured on a test piece following the method specified in this International Standard, which represents the diameter of a circle with the same circumference as the perimeter of the sample being measured, provided that the boundary of its cross section is convex

Note 1 to entry: The result of the measurement can be affected by n , the number of readings taken.

3.2

convex cross section

a cross section where the straight line between any two points from the section is also included within the section

3.3

perimeter

length of the line that is the boundary of the cross section

Note 1 to entry: Errors will exist in the estimated value of the perimeter if the sample is not circular. The error will increase as the ovality increases.

3.4

circumference

perimeter of a circular cross section

3.5
minimum diameter

minimum value obtained from the results of n individual readings performed on a test piece

3.6
maximum diameter

maximum value obtained from the results of n individual readings performed on a test piece

3.7
absolute ovality

expression of the out-of-roundness of a rod-like test piece, which is obtained from the arithmetic difference between the maximum and minimum diameters obtained from n individual readings

3.8
relative ovality

ratio of the absolute ovality and the diameter, expressed as a percentage

3.9
relative roundness

100 minus relative ovality

Note 1 to entry: Caution should be exercised in interpreting maximum diameters, absolute ovality, relative ovality and relative roundness as these can be affected by the quality of the gum line (raised laps) or other product defects, generating erroneous individual readings.

4 Principle

The principle of measurement of the mean diameter of a shape having a convex cross section follows the generalization of 'Barbier's Theorem', which states that the mean diameter of a section is equal to the arithmetic mean of the apparent (or projected) diameters of the section as it is rotated at equiangular intervals in the field of view. It is required that the section is rotated by an integer multiple of 180° .

NOTE The principle is demonstrated in [Annex B.1](#).

5 Apparatus

5.1 Sample conditioning enclosure, to be capable of maintaining the conditions given in ISO 3402.

5.2 Optical measuring apparatus, to consist of the following.

5.2.1 Optical measuring instrument

This must have an uncertainty of no more than 0,01 mm and be suitable for the determination of the diameter of rod-like test pieces with a nearly circular cross section. A schematic diagram of such an instrument is presented in [Figure 1](#) and three different implementations are described in [Annex D](#).

The scanning rate of the instrument shall be such that no eccentric motion of the test piece parallel to the longitudinal axis, within the measurement area, shall affect the accuracy of the measurement of mean diameter.

The ratio between the scanning rate of the apparatus and the rotational speed of the test piece shall be constant and high enough to ensure that the measured diameter, as well as the minimum and maximum values, shall be determined with sufficient accuracy, despite the possible ovality of the test piece.

The length of the scan path shall be sufficiently greater than the maximum diameter to be measured to avoid errors due to test piece eccentricity. The test piece shall be scanned a minimum of 32 times during a half-rotation (180°) or 64 times during a full (360°) rotation.

NOTE The rationale for the required number of scans is presented in [Annex B.2](#).

5.2.2 Apparatus or fixture for rotating the test piece or scan path

This shall rotate the test piece within the measurement area or rotate the direction of view around the test piece while maintaining the longitudinal axis of the test piece perpendicular to the measurement area during a full 360° rotation.

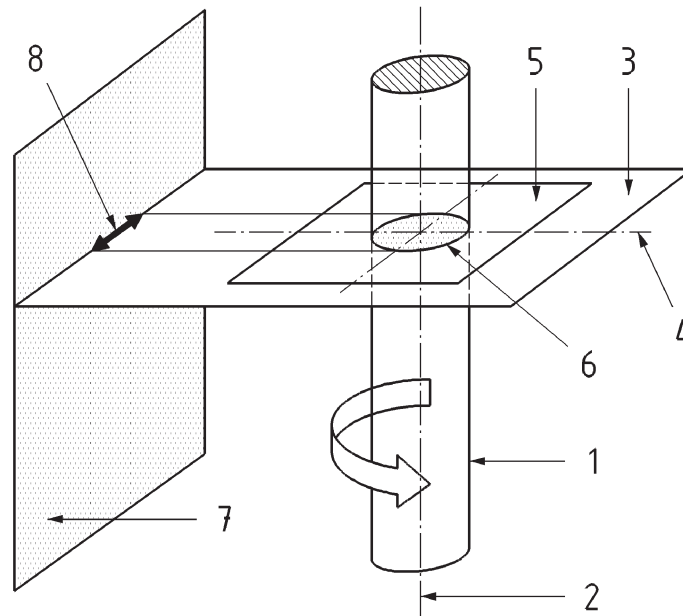

Key

- 1 test piece
- 2 test piece longitudinal axis and axis of rotation
- 3 plane of the measurement
- 4 measurement centreline
- 5 measurement area
- 6 test piece cross section
- 7 projection plane
- 8 apparent diameter (orthogonal projection or image) of the test piece cross section

Figure 1 — Diagram of a generic non-contact optical gauging system

6 Sampling

Take a statistically representative sample of the population of test pieces to be characterized.

Samples shall be free of obvious visible defects which may affect the measurement.

7 Procedure

7.1 Preparation of test pieces

Condition the test pieces, prior to measurement, in a conditioning enclosure in accordance with ISO 3402.

Select at random, from the sample taken in accordance with [Clause 6](#), the number of test pieces required for the test.

The time required for the curing of filter rods and the duration of conditioning for both filter rods and cigarettes are not specified in this International Standard and are to be determined by practical experience. They shall be reported in the test report together with the results.

7.2 Adjustment and calibration

Working standards are routinely used to adjust calibrate or check the calibration of the measurement system. Calibration shall be performed in accordance with the manufacturer's instructions.

NOTE The essential properties of calibration standards are given in [Annex A](#).

7.3 Measurement

In accordance with the manufacturer's instructions, position the test piece within the measurement area, as close as possible to the centre of the measurement area.

The test piece, or the measuring apparatus, shall be capable of being rotated around the rotation axis such that any eccentric motion of the test piece, relative to the plane of the measurement, remains in parallel with the plane of the measurement and perpendicular to the longitudinal axis of the test piece.

Adjust the instrument and/or feeding and rotational apparatus for the plane of the measurement to measure the required section of the test piece.

Operate the apparatus in accordance with the manufacturer's instructions and accurately record the mean, minimum and maximum diameters.

At least 10 test pieces from one sample shall be used to determine the mean value of the diameter for the sample.

NOTE 1 In practice, laboratories often take a different number of measurements depending on the application of the measurement.

NOTE 2 Possible sources of error in measurement of diameter are given in [Annex C](#).

8 Expression of results

The value of the sample mean diameter shall be the mean value of the individual measurements. See [7.3](#).

The results shall be expressed as follows:

- a) diameter, the arithmetic average of at least 64 individual scans per full revolution or 32 scans per half revolution, is expressed in millimetres to the nearest 0,01 mm ;
- b) sample mean diameter, the average of x diameter measurements (x is normally 10 but may vary; see note 1 in 7.3) is expressed in millimetres to the nearest 0,001 mm ;
- c) sample maximum diameter, the maximum diameter obtained from a sample of x test pieces, is expressed in millimetres to the nearest 0,01 mm ;
- d) sample minimum diameter, the minimum diameter obtained from a sample of x test pieces, is expressed in millimetres to the nearest 0,01 mm ;
- e) absolute ovality is expressed in millimetres to the nearest 0,01 mm ;
- f) relative ovality is expressed as a percentage to the nearest 0,1 % ;
- g) relative roundness is expressed as a percentage to the nearest 0,1 %.

9 Repeatability and reproducibility

An international collaborative study involving 14 laboratories was conducted according to ISO 5725-2:1994 in 2009 on matched samples of both filter rods and cigarettes covering a range of approximately 5 mm to 9 mm diameter.

Each measured sample was drawn randomly from a population of typically 3000 rods that, as far as was possible, represented a consistent production process. Three samples of 10 rods, plus spares, were distributed to each participant. Each sample of 10 rods was measured once only. The measurement position for the cigarettes was specified to be on the tobacco column. The measurement position for the filters was not specified.

NOTE 1 Specific details of the measurement protocol are given in [Annex E](#).

The study gave the following values (see Table 1) for mean diameter, repeatability standard deviation (s_r), reproducibility standard deviation (s_R), repeatability limit (r) and reproducibility limit (R). The values derived from this interlaboratory study may not be applicable to values and matrices other than those given because the samples being used did not cover all available products.

Table 1 — Summary of results of collaborative study

Product type	Mean diameter	s_r	s_R	r	R	Comment
	mm	mm	mm	mm	mm	
Mono acetate filter rods, nominally circular cross section	5,335	0,0039	0,0157	0,011	0,044	Non porous
	6,026	0,0031	0,0105	0,009	0,029	Non porous
	6,780	0,0055	0,0137	0,015	0,038	Porous
	7,715	0,0035	0,0131	0,010	0,037	Non porous
	8,511	0,0059	0,0110	0,017	0,031	High porosity
White paper cigarettes, nominally circular cross section	5,428	0,0104	0,0205	0,029	0,057	Unpacked
	6,102	0,0072	0,0156	0,020	0,044	Unpacked
	6,826	0,0035	0,0066	0,010	0,018	Packed
	7,828	0,0047	0,0105	0,013	0,029	Unpacked
	8,612	0,0060	0,0111	0,017	0,031	Unpacked

NOTE 2 The comment for filters refers to the porosity of the filter plug wrap papers, which were in the following ranges: Non porous: < 10 CORESTA Units ; Porous: < 10000 CORESTA Units ; High porosity: > 10000 CORESTA Units

10 Test report

The test report shall indicate the method used and the results obtained. It shall also mention any operating conditions not specified in this International Standard, or regarded as optional, as well as any circumstances that may have influenced the results. The test report shall include all details required for complete identification of the sample.

Specifically the test report shall contain:

- a) date of sampling and sampling method;
- b) identification and full description of the samples tested, stating the properties (nature, size) of samples;
- c) date of measurement;
- d) precise and full measuring conditions, particularly those deviating from the specifications of this International Standard, and any events likely to have affected the results;
- e) test atmosphere and duration of conditioning (see [7.1](#));

- f) measurement position for cigarettes – distance from mouth end;
- g) results expressed in millimetres (diameter or circumference);
- h) elementary statistics relative to results:
 - number of measurements;
 - mean and standard deviation values.

Annex A **(normative)**

Calibration standards

A.1 Essential properties of calibration standards

Calibration standards are used to calibrate measuring instruments for the determination of the diameter (or circumference) of cigarettes and filter rods.

The reference calibration standard shall be a cylindrical rod made of a rigid, stable material (such as steel) with a ground surface finish of about 0,5 μm average roughness and with a known and repeatable value of the diameter.

The working calibration standard shall be calibrated against a traceable reference standard under standard laboratory conditions of (22 ± 2) °C. The thermal expansion coefficient of the material shall be known.

The working calibration standard shall be checked for ovality by measuring the diameters of a minimum of three cross-sections, situated near the middle and two ends respectively.

The calibration standards shall be certificated with their measured value quoted to a minimum accuracy of the diameter of 0,003 mm absolute and have a unique identification.

A.2 Procedure for calibration of instruments

The calibration and performance testing of instruments for the determination of the diameter of cigarettes and filter rods should be conducted in accordance with instrument manufacturer's instructions.

Annex B (informative)

Measurement principle and required number of scans

B.1 Demonstration of measurement principle

Figure B.1 presents a schematic illustration of the cross section (X) of a cigarette or filter rod bounded by a convex curve:

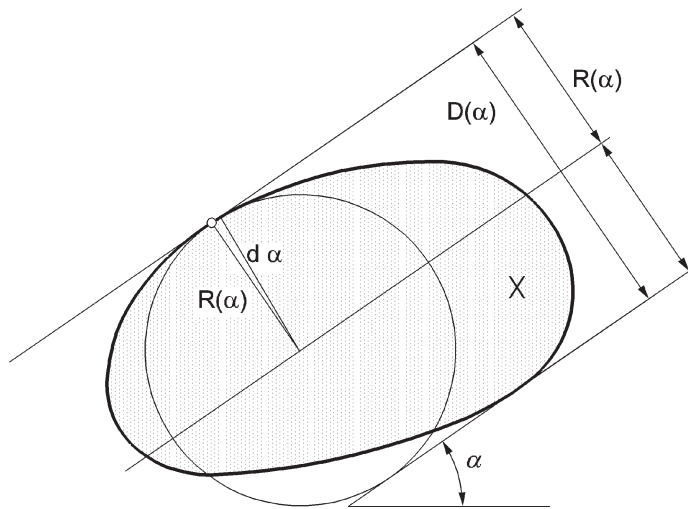

Figure B.1 — Schematic illustration of the cross section of a cigarette or filter rod (X) and its apparent diameter $D(\alpha)$ seen at an arbitrary angle α

A circle is constructed tangential to the cross section where it meets one supporting line and with a diameter is equal to the apparent diameter, $D(\alpha)$, of the section seen at angle α . The radius of the circle is $R(\alpha) = D(\alpha)/2$ and its circumference is $2\pi R(\alpha)$. The length of the arc of the circle corresponding to an angle subtended at the centre $d\alpha$ is $R(\alpha)d\alpha$.

For a small angle $d\alpha$ the length of the arc of the circle approaches the length of the arc of the cross section (as $d\alpha \rightarrow 0$, so both arcs approach straight lines, so their lengths must be equal).

The perimeter of the cross section, P , can therefore be calculated by summing the individual arc lengths corresponding to each angular step $d\alpha$ as the shape is rotated through 1 revolution. Thus,

$$P = \int_0^{2\pi} R(\alpha) d\alpha = \frac{1}{2} \int_0^{2\pi} D(\alpha) d\alpha = \pi \left(\frac{1}{2\pi} \int_0^{2\pi} D(\alpha) d\alpha \right) \quad (1)$$

It is known that the mean of a function $f(x)$ between two values a and b is: $\frac{1}{b-a} \int_a^b f(x) dx$ (2)

Thus the average of the apparent diameters, D_{mean} of the cross section is: $D_m = \frac{1}{2\pi} \int_0^{2\pi} D(\alpha) d\alpha$ (3)

Comparing (1) and (3) it can be seen that: $P = \pi D_m$ (4)

This demonstrates that the perimeter of a convex curve is equal to the mean of the apparent diameters multiplied by π . In other words the mean of the apparent diameters of a cigarette or filter rod is equal to its perimeter divided by π and is independent of its shape as long it remains convex.

This treatment makes the assumption that the cross section is rotated through 360° , but all diameters are sampled if the rotation is through only 180° . Sampling through a non-integer multiple of 180° will bias the result according to the shape of the sample.

B.2 Required number of scans

The measurement principle described above is based on an infinite number of diameter scans. Any practical instrument makes a finite number of diameter scans, which affects the accuracy of the measurement. A theoretical study undertaken by the Working Group showed that 36 individual scans performed on a full rotation at constant angular interval of an elliptical shape whose relative ovality is less than 40 %, provided $1 \mu\text{m}$ accuracy on the diameter and 1 point accuracy on the relative ovality determination. An experimental study using a laser device showed that 64 individual scans performed on a full rotation at a constant angular speed of a test piece whose ovality is less than 30 %, provided a difference lower than $1 \mu\text{m}$ on the mean diameter and 0,2 point on the relative ovality determination compared with a determination 1024 based on individual scans.

On the basis of these studies it is recommended to carry out a minimum of 64 scans on a full rotation, or 32 scans on a half rotation, at constant angular interval of the test piece.

Annex C **(informative)**

Information on possible source of measurement error

C.1 Sources of error that are common to laser, CCD and camera systems

- Sample rod not perpendicular to beam;
- Incorrect measurement position along sample rod length;
- Sample surface roughness;
- Aberrations due to poor optics;
- Sample rod rotation is not a multiple of 180°;
- Angular rotation speed not constant;
- Acquisition rate not constant;
- Number of scans per rotation not high enough;
- Dirt in system can cause incorrect edge interpretation;
- Selection of test pieces that have raised seams (bad laps);
- Incorrect placing of the test piece in the measurement area of the system;
- Use of test piece with ill-defined edge characteristics such as non-wrapped acetate filter plugs.

C.2 Sources of error that are specific to camera systems

- Variations in sample range;
- Shadows due to poor lighting;
- Calibration based on a product's diameter, colour, brightness or contrast that is different from the measured product;
- Colour variations of the product due to poor lighting;
- Colour changes of the product from one measurement area to another;
- Distance variation between the optics and the product;
- Very narrow measurement width can result in high sensitivity to measurement position along rod;
- Very wide measurement width can result in low sensitivity to measurement position along rod;
- Sensor resolution not appropriate for measurement resolution.

C.3 Sources of error that are specific to CCD systems

- Collimated beam may not be exactly parallel;
- Very narrow measurement width can result in high sensitivity to measurement position along rod;

- Very wide measurement width can result in low sensitivity to measurement position along rod;
- Absolute resolution not appropriate for measurement resolution.

C.4 Sources of error that are specific to laser systems

- Collimated beam may not be exactly parallel;
- Instability of the lateral beam speed;
- Very narrow beam width can result in high sensitivity to measurement position along rod;
- Very narrow beam width can result in errors due to detection of small artefacts (fibres) on surface of test piece.

Annex D (informative)

Non-contact measurement techniques

D.1 Measuring apparatus using a laser beam

The laser beam emitted by a semiconductor laser is cast on and reflected from an octagonal mirror and a reflection mirror. The diffused laser beam is then parallelized by a collimator lens and thrown upon the object to be measured. The beam moves in the scan path at a constant speed and parallel to itself. After scanning the object the laser beam is converged by a receiver lens to a receiver element. An edge detection device generates a pulse when the beam reaches the object and another one when it leaves the object. The elapsed time between the 2 pulses is proportional to the size of the object.

This principle is illustrated in [Figure D.1](#).

An appropriate device is used to maintain the rod perpendicular to the scan path and to rotate the rod at a constant angular speed along its longitudinal axis.

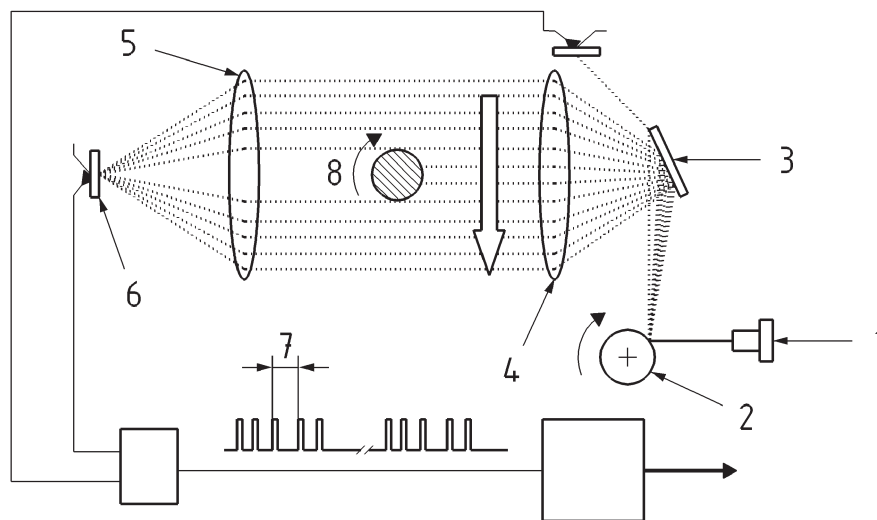

Key

- 1 laser emitter
- 2 octagonal mirror
- 3 reflection mirror
- 4 collimator lens
- 5 receiver lens
- 6 receiver element
- 7 Φ = time measurement
- 8 rod

Figure D.1 — Diagram of a laser gauging system

D.2 Measuring apparatus using a CCD device

The light beam emitted by a LED is parallelized by a collimator lens and thrown upon the object to be measured. After scanning the object the beam is converged by a converging lens and parallelized on a CCD array. The size of the shadow projected on the CCD array is proportional to the size of the object.

This principle is illustrated in [Figure D.2](#).

An appropriate device is used to maintain the rod perpendicular to the scan path and to rotate the rod at a constant angular speed along its longitudinal axis.

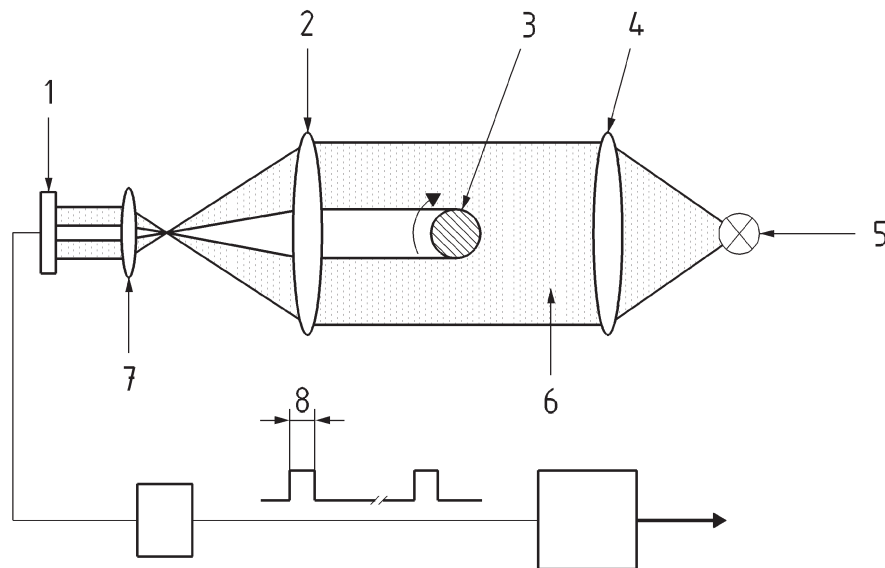

Key

- 1 CCD array
- 2 converging lens
- 3 test piece
- 4 collimator lens
- 5 LED
- 6 parallelized light beam
- 7 receiving lens
- 8 Φ = distance measurement

Figure D.2 — Diagram of a CCD gauging system

D.3 Measuring apparatus using a video camera and digital image processing system

The object is rotated in the field of view of a digital video camera. An appropriate device is used to maintain the rod perpendicular to the scan path and to rotate the rod along its longitudinal axis.

The object is imaged on to the digital imaging sensor within the camera. The digital images are scanned and captured by a digital image processing system with image processing software.

The size of the object in the image is determined by reference to similar images captured from a series of calibration standards.

This principle is illustrated in [Figure D.3](#).

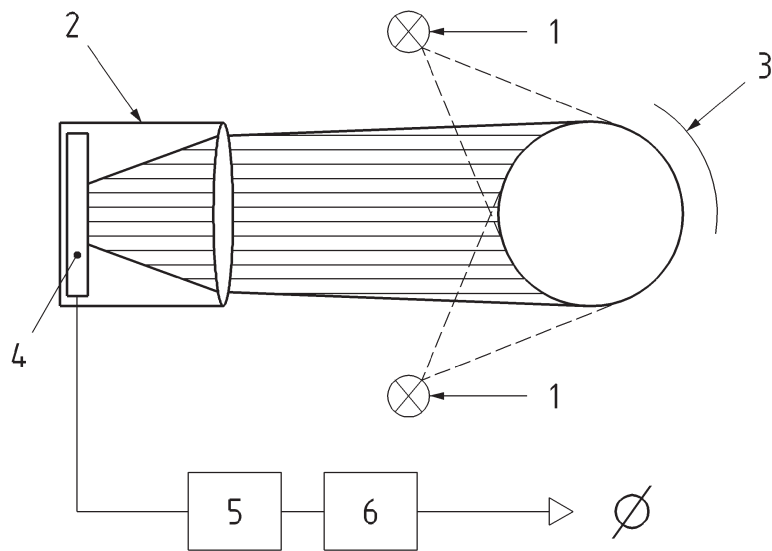

Key

- 1 sample illumination
- 2 video camera
- 3 sample and rotation device
- 4 digital imaging device
- 5 digital image processing hardware
- 6 digital image processing software

Figure D.3 — Diagram of a video camera and digital image processing system

Annex E (informative)

Alternative measurement techniques for the determination of nominal diameter of cigarettes and filter rods

E.1 Tape gauge measurement

E.1.1 Principle

This measurement technique employs a flexible tape which is wrapped around the outside of a cigarette or filter rod and held with a controlled tension, applied by means of a drop-weight of a chosen value of between 60 g to 100 g.

One end of the tape is attached to a transducer, used to relate linear travel to a directly proportional voltage; the other end is anchored to a datum.

The tape, when wrapped around the sample, precisely conforms to the shape of the sample. Therefore the remaining length of tape, which directly relates to the perimeter of the sample, is measured.

E.1.2 Advantages

The advantage of the tape gauge is that it precisely measures the perimeter of the sample, regardless of its shape, and overcomes any problems that could be incurred by other techniques due to the presence of raised laps. The method also has the advantage of working consistently with ill-defined peripheries such as are found on non-wrapped acetate filter rods. Measurement of the perimeter provides greater resolution of measurement in determining the nominal diameter.

E.1.3 Disadvantages

The disadvantage of the tape gauge is that a range of drop-weights are required to negate any constricting effect on low density products and that the tape gauging technique cannot determine the maximum and minimum diameters of a product. Nominal diameter is calculated from the measured value of the perimeter.

NOTE The chosen drop-weight will affect the diameter measured, especially when measuring cigarette diameter directly after manufacture.

E.2 Pneumatic balancing orifice measurement

E.2.1 Principle

A pneumatic bridge circuit is supplied with air at very low regulated pressure and is divided along two paths, one for measurement and the other for balancing.

A manometer or differential pressure sensor is used to indicate the difference in pressure between the measuring and balancing lines, as determined by the size of the sample, placed in the measuring head.

This measurement directly relates to the cross-sectional area of the sample, which is subsequently reported as nominal diameter or circumference.

E.2.2 Advantages

This measurement technique has the advantages that it is simple and requires little technological support and only requires a compressed air supply to function.

A manometer and scale provide an easy-to-read indication of any specified mean circumference or diameter, and of deviations from it in fractions of a millimetre.

E.2.3 Disadvantages

Distinct measurement heads are required for each measurement range, typically $\pm 0,25$ mm diameter ($\pm 0,7$ mm circumference), relative to any specific nominal diameter or circumference.

Measurements are mainly affected by the level of permeability of the sample wrapper and some also by the bulk density of the sample.

Annex F (informative)

Protocol for ISO/TC 126/SC 1/WG 2 interlaboratory diameter measurement uncertainty study

F.1 Introduction

The aim of the study is to assess the repeatability and reproducibility of the ISO 2971, *Cigarettes and filter rods – Determination of nominal diameter – Method using a non contact optical measuring apparatus*.

The study is designed as a balanced uniform level experiment, according to ISO 5725-2, in which 5 cigarette samples and 5 filter samples representing different diameter levels of the test are sent to participating laboratories. Participating laboratories were recruited from members of ISO/TC 126/SC 1/WG 2. Instrumentation used included all the types described in [Annex D](#).

F.2 Scope

This document describes how the cross-check procedure shall be conducted by an individual participating laboratory.

F.3 Procedure

F.3.1 Cigarette and filter samples will be distributed to the participating laboratories by one coordinating partner.

F.3.2 The measurements shall be carried out as follows:

F.3.3 Carry out any preliminary checking and calibration of equipment as specified in the standard and/ or manufacturer's handbook

F.3.4 For each individual product, measure 3 separate samples of 10 items. For each sample report the individual measurements, the sample mean and sample standard deviation in the worksheet provided.

F.3.5 It is important that the measurements on each level of sample are carried out under repeatability conditions, i.e. within a short interval of time, by the same operator, without any intermediate calibration of the apparatus.

F.3.6 It is not essential that all sample levels each be performed within a short interval, and different sample levels may be performed on different days, but the 10 measurements on each sample level must be performed strictly within a short interval.

F.3.7 All measurements should be performed by the same operator, and the same equipment throughout.

F.3.8 Laboratories wishing to submit results from more than one instrument in the same laboratory or location should treat each instrument as if it were in a different location (e.g. use a different operator, measure samples on different days).

F.4 Data reporting

For each sample of 10 rods the required data are:

- mean diameter (*not circumference*) to 0,001 mm;
- standard deviation of diameter to 0,001 mm.

Also report the individual measurements (to 0,01 mm) for each sample, the measurement position used to measure diameter, and the ambient temperature and humidity.

Bureau of Indian Standards

BIS is a statutory institution established under the *Bureau of Indian Standards Act, 2016* to promote harmonious development of the activities of standardization, marking and quality certification of goods and attending to connected matters in the country.

Copyright

BIS has the copyright of all its publications. No part of these publications may be reproduced in any form without the prior permission in writing of BIS. This does not preclude the free use, in course of implementing the standard, of necessary details, such as symbols and sizes, type or grade designations. Enquiries relating to copyright be addressed to the Director (Publications), BIS.

Review of Indian Standards

Amendments are issued to standards as the need arises on the basis of comments. Standards are also reviewed periodically; a standard along with amendments is reaffirmed when such review indicates that no changes are needed; if the review indicates that changes are needed, it is taken up for revision. Users of Indian Standards should ascertain that they are in possession of the latest amendments or edition by referring to the latest issue of 'BIS Catalogue' and 'Standards: Monthly Additions'.

This Indian Standard has been developed from Doc No.: FAD 04 (2731).

Amendments Issued Since Publication

Amendment No.	Date of Issue	Text Affected

BUREAU OF INDIAN STANDARDS

Headquarters:

Manak Bhavan, 9 Bahadur Shah Zafar Marg, New Delhi 110002

Telephones: 2323 0131, 2323 3375, 2323 9402

Website: www.bis.gov.in

Regional Offices:

Central : Manak Bhavan, 9 Bahadur Shah Zafar Marg
NEW DELHI 110002

Telephones

{ 2323 7617
2323 3841

Eastern : 1/14, C.I.T. Scheme VII M, V.I.P. Road, Kankurgachi
KOLKATA 700054

{ 2337 8499, 2337 8561
2337 8626, 2337 9120

Northern : Plot No. 4-A, Sector 27-B, Madhya Marg, CHANDIGARH 160019

{ 26 50206
265 0290

Southern : C.I.T. Campus, IV Cross Road, CHENNAI 600113

{ 2254 1216, 2254 1442
2254 2519, 2254 2315

Western : Manakalaya, E9 MIDC, Marol, Andheri (East)
MUMBAI 400093

{ 2832 9295, 2832 7858
2832 7891, 2832 7892

Branches : AHMEDABAD. BENGALURU. BHOPAL. BHUBANESWAR. COIMBATORE.
DEHRADUN. DURGAPUR. FARIDABAD. GHAZIABAD. GUWAHATI.
HYDERABAD. JAIPUR. JAMMU. JAMSHEDPUR. KOCHI. LUCKNOW. NAGPUR.
PARWANOO. PATNA. PUNE. RAIPUR. RAJKOT. VISAKHAPATNAM.