

निजी सुरक्षा उपस्कर
भाग 1 फुटवियर की परीक्षण पद्धतियाँ
(तीसरा पुनरीक्षण)

Personal Protective Equipment
Part 1 Test Methods for Footwear
(Third Revision)

ICS 13.340.50

© BIS 2024



भारतीय मानक ब्यूरो
BUREAU OF INDIAN STANDARDS
मानक भवन, 9 बहादुर शाह ज़फर मार्ग, नई दिल्ली - 110002
MANAK BHAVAN, 9 BAHADUR SHAH ZAFAR MARG
NEW DELHI - 110002
www.bis.gov.in www.standardsbis.in

July 2024

Price Group 20

NATIONAL FOREWORD

This Indian Standard (Part 1) (Third Revision) which is identical to ISO 20344 : 2021 'Personal protective equipment — Test methods for footwear' issued by the International Organization for Standardization (ISO), was adopted by the Bureau of Indian Standards after the draft finalized by the Footwear Sectional Committee had been approved by the Chemical Division Council

This document specifies methods for testing footwear designed as personal protective equipment.

This Indian Standard is published in several parts. The other parts in this series are:

- Part 2 Safety Footwear
- Part 3 Protective footwear
- Part 4 Occupational footwear
- Part 5 Additional requirements and test methods
- Part 6 Additional specifications for safety footwear
- Part 7 Additional specifications for protective footwear
- Part 8 Additional specification for occupational footwear

This standard was first published in 2002 which was identical to ISO 8782-1 : 1998 .The standard was revised in 2011 by adopting ISO 20344 : 2004 which was revision of ISO 8782-1.The standard was subsequently revised in 2015 to adopt the latest version of ISO 20344.

This third revision has been undertaken to adopt the latest version of ISO 20344 : 2021 along with amendment no. 1, published in 2024. During this revision, following changes have been made:

- a) For each test same organization (1 principle 2 test equipment's 3 sampling and conditioning 4 test method 5 test report);
- b) Systematic inclusion of a clause test report in all the test methods;
- c) Changes in Table 1, minimum number of samples and test pieces;
- d) Several tests are not described anymore in this standard but in the corresponding standard, reference is made to specific standards (ISO 22649, ISO 11640, ISO 17707, etc...);
- e) All reference standards are dated in clause **2**;
- f) New standards are taken into account (ISO 17075-1 and ISO 17075-2, ISO 22568-1 to ISO 22568-4);
- g) Conditioning changed from 48 h to 24 h in **4.2**;
- h) Slip resistance, new test condition in **5.14**;
- j) Non-metallic perforation resistant insert, reference to the new ISO 22568-4 in **5.10**;
- k) New drawing for impact test in **5.4**;
- m) New detection of water resistance in **5.18.4**;
- n) New detection of water resistance in **5.19.4**;
- p) Clarification in the position and the dimension of the ankle protection in **5.21.2**;
- q) New tests for scuff caps, in **5.24**;
- r) New tests for seam strength in **5.25**;
- s) Determination of the area for non-water vapour permeable material in **6.2.3**;

- t) New measurement of cleats height in the waist area in **8.2.4**;
- u) New Annex A with new drawings of footwear degradations; and
- v) New Annex B added with new system of sizing.

Subsequently, ISO has published an amendment no. 1 to this standard, which has been adopted with the revised version. In this amendment, following changes have been made:

- a) Clause **4.2, 5.1.3, 5.2.4.3, 5.5.3.3, 5.7.4, 5.10.4.1, 5.10.5, 5.11.3, 5.12.3, 5.15.4, 5.18.1, 5.18.4.2, 5.18.5, 5.19.4.2.7, 5.19.5, 5.20.1.4.3, 5.21.3, 5.22.3, 5.22.4.2, 6.2.3.1, 6.2.3.2, 6.5.2.2.1.2, 6.5.3, 6.6.4, 6.10.3, 6.12.4.3, 6.12.5, 7.3.2.3, 7.3.4.1.1, 7.3.4.3, 8.4.3, 8.9.1.1 and 8.9.4** have been modified;
- b) Figure 1 has been changed;
- c) Table 1 and Table 2 have been modified; and
- d) Bibliography has been updated.

The text of ISO standard has been approved as suitable for publication as an Indian Standard without deviations. Certain conventions and terminologies are, however, not identical to those used in Indian Standards. Attention is particularly drawn to the following:

- a) Wherever the words 'International Standard' appear referring to this standard, they should be read as 'Indian Standard'; and
- b) Comma (,) has been used as a decimal marker in the International Standard, while in Indian Standards, the current practice is to use a point (.) as the decimal marker.

In this adopted standard, reference appears to certain International Standards for which Indian Standards also exist. The corresponding Indian Standards, which are to be substituted in their places, are given below along with their degree of equivalence for the editions indicated:

<i>International Standard</i>	<i>Corresponding Indian Standard</i>	<i>Degree of Equivalence</i>
ISO 34-1 : 2015 — Rubber, vulcanized or thermoplastic — Determination of tear strength — Part 1: Trouser, angle and crescent test pieces	IS 3400 (Part 12) : 2022/ ISO 34-1 : 2015 Methods of test for vulcanized rubbers: Part 12 Tear strength-crescent test piece (<i>first revision</i>)	Identical
ISO 1817 : 2015 — Rubber, vulcanized or thermoplastic Determination of the effect of liquids	IS 3400 (Part 6) : 2018/ ISO 1817 : 2015 Methods of test for vulcanized rubbers: Part 6 Determination of the effect of liquids (<i>fourth revision</i>)	Identical
ISO 11640 : 2018 Leather — Tests for colour fastness — Colour fastness to cycles of to-and-fro rubbing	IS 6191 (Part 4) : 2018/ ISO 11640 : 2012 Methods of micro-biological, colour fastness and microscopical tests for leather: Part 4 Colour fastness to cycles of to-and-fro rubbing	Identical
ISO 3290-1 : 2014 Rolling bearings — Balls — Part 1: Steel balls	IS 2898 (Part 1) : 2019/ ISO 3290-1 : 2014 Rolling bearings — Balls: Part 1 Steel balls (<i>second revision</i>)	Identical
ISO 3376 : 2020 Leather — Physical and mechanical tests — Determination of tensile strength and percentage elongation	IS 5914 (Part 8) : 2023/ ISO 3376 : 2020 Methods of physical testing of leather: Part 8 Determination of tensile strength and percentage elongation	Identical

<i>International Standard</i>	<i>Corresponding Indian Standard</i>	<i>Degree of Equivalence</i>
ISO 3377-2 : 2016 Leather — Physical and mechanical tests — Determination of tear load — Part 2: Double edge tear	IS 5914(Part 5/Sec 2) : 2023/ ISO 3377-2 : 2016 Methods of physical testing of leather: Part 5 Determination of tear load, Section 2 Double edge tear	Identical
ISO 4045 : 2018 Leather — Chemical tests — Determination of pH and difference figure	IS 582 (Part 9) : 2022/ ISO 4045 : 2018 Methods of chemical testing of leathers: Part 9 Determination of pH and difference figure	Identical
ISO 4649 : 2017 Rubber vulcanized or thermoplastic — Determination of abrasion resistance using a rotating cylindrical drum device	IS 3400 (Part 3) : 2021/ISO 4649 : 2017 Methods of test for vulcanized rubber: Part 3 Abrasion resistance using a rotating cylindrical drum device (<i>third revision</i>)	Identical
ISO 4674-1 : 2016 Rubber-or plastics-coated fabrics — Determination of tear resistance — Part 1: Constant rate of tear methods	IS 7016 (Part 3/Sec 1) : 2022/ ISO 4674-1 : 2016 Methods of test for coated and treated fabrics: Part 3 Determination of tear resistance, Section 1 Constant rate of tear methods (<i>second revision</i>)	Identical
ISO 5423 : 1992 Moulded plastics footwear — Lined or unlined polyurethane boots for general industrial use — Specification	IS 16645 : 2018/ ISO 5423 : 1992 Moulded plastics footwear — Lined or unlined polyurethane boots for general industrial use — Specification	Identical
ISO 7500-1 : 2018 Metallic materials — Calibration and verification of static uniaxial testing machines — Part 1: Tension/compression testing machines — Calibration and verification of the force measuring system	IS 1828 (Part 1) : 2022/ ISO 7500-1 : 2018 Metallic materials — Calibration and verification of static uniaxial testing machines: Part 1 Tension/compression testing machines— Calibration and verification of the force measuring system (<i>fifth revision</i>)	Identical
ISO 12947-1 : 1998+Cor. 1 : 2002 Textiles — Determination of the abrasion resistance of fabrics by the Martindale method — Part 1 Martindale abrasion testing apparatus	IS 12673 (Part 1) : 2014/ ISO 12947-1 : 1998 Textiles — Determination of the abrasion resistance of fabrics by the martindale method: Part 1 Martindale abrasion testing apparatus (<i>first revision</i>)	Identical
ISO 17075-1 : 2017 Leather — Chemical determination of chromium (VI) content in leather — Part 1: Colorimetric method	IS 582 (Part 11/Sec 1) : 2023/ ISO 17075 : 2017 Methods of chemical testing of leather: Part 11 Determination of chromium (VI) content in leather, Section 1 Colorimetric method	Identical

<i>International Standard</i>	<i>Corresponding Indian Standard</i>	<i>Degree of Equivalence</i>
ISO 17075-2 : 2017 Leather — Chemical determination of chromium (VI) content in leather — Part 2: Chromatographic method	IS 582 (Part 11/Sec 2) : 2022/ ISO 17075- 2 : 2017 Methods of chemical testing of leather: Part 11 Determination of chromium (VI) content in leather, Section 2 Chromatographic method	Identical
ISO 17697 : 2016 Footwear — Test methods for uppers, lining and insoles — Seam strength	IS 8085 (Part 13) : 2023/ ISO 17697 : 2016 Methods of test for footwear: Part 13 Seam strength for uppers lining and insoles	Identical
ISO 20345 : 2021 — Personal protective equipment — Safety footwear	IS 15298 (Part 2) : 2024/ ISO 20345 : 2021 — Personal protective equipment — Safety footwear (<i>third revision</i>)	Identical
ISO 20346 : 2021 Personal protective equipment — Protective footwear	IS 15298 (Part 3) : 2024/ ISO 20346 : 2021 Personal protective equipment — Protective footwear (<i>third revision</i>)	Identical
ISO 20347 : 2021 Personal protective equipment — Occupational footwear	IS 15298 (Part 4) : 2024/ ISO 20347 : 2021 — Personal protective equipment — Occupational footwear (<i>third revision</i>)	Identical
ISO 23388 : 2018 — Protective gloves against mechanical risks	IS 6994 (Part 6) : 2021/ ISO 23388 : 2018 Protection of arms and hands: Part 6 Protective gloves against mechanical risks	Identical
ISO 22568-3 : 2019 — Foot and leg protectors — Requirements and test methods for footwear components — Part 3: Metallic perforation resistant inserts	IS 17275 (Part 1) : 2019/ ISO 22568- 3 : 2019 Perforation resistant inserts for protection of feet — Specification: Part 1 Metallic perforation resistant inserts	Identical
ISO 22568-4 : 2021 Foot and leg protectors — Requirements and test methods for footwear components — Part 4 Non-metallic perforation resistant inserts	IS 17275 (Part 2) : 2019/ ISO 22568- 4 : 2019 Perforation resistant inserts for protection of feet — Specification: Part 2 Non-metallic perforation resistant inserts	Identical
ISO 23529 : 2016 Rubber — General procedures for preparing and conditioning test pieces for physical test methods	IS 13867 : 2021/ ISO 23529 : 2016 Rubber — General procedures for preparing and conditioning test pieces for physical test methods (<i>first revision</i>)	Identical

The Committee has reviewed the provisions of the following International Standards referred in this standard and has decided that they are acceptable for use in conjunction with this standard:

<i>International Standard</i>	<i>Title</i>
ISO 4643 : 1992	Moulded plastics footwear — Lined or unlined poly (vinyl chloride) boots for general industrial use — Specification
ISO 5403-1 : 2011	Leather — Determination of water resistance of flexible leather — Part 1: Repeated linear compression (penetrometer)
ISO 6487 : 2015	Road vehicles — Measurement techniques in impact tests — Instrumentation
ISO 13287 : 2019	Personal protective equipment — Footwear — Test method for slip resistance
ISO 14268 : 2012	Leather — Physical and mechanical tests — Determination of water vapour permeability
ISO 17707 : 2005	Footwear — Test methods for outsoles — Flex resistance
ISO 22568-1 : 2019	Foot and leg protectors — Requirements and test methods for footwear components — Part 1: Metallic toecaps
ISO 22649 : 2016	Footwear — Test methods for insoles and insocks — Water absorption and desorption

Conditioning and test atmospheres stipulated in this standard may not be applicable to tropical/subtropical countries like India. The applicable standard atmospheric conditions (SAC) for Indian conditions are $27^{\circ}\text{C} \pm 2^{\circ}\text{C}$ and (65 ± 5) percent relative humidity and may be observed while using this standard.

In reporting the result of a test or analysis made in accordance with this standard, if the final value, observed or calculated, is to be rounded off, it shall be done in accordance with IS 2 : 2022 'Rules for rounding off numerical values (*second revision*)'.

Contents

Page

1	Scope	1
2	Normative references	1
3	Terms and definitions	2
4	General testing parameters	2
4.1	Sampling.....	2
4.2	Conditioning before and during the test.....	3
4.3	Prerequisites on the testing procedure.....	3
4.4	Test report.....	3
5	Test methods for whole footwear	6
5.1	Specific ergonomic features.....	6
5.1.1	Sampling and conditioning.....	6
5.1.2	Test method.....	7
5.1.3	Test report.....	7
5.2	Determination of upper/outsole and sole interlayer bond strength.....	8
5.2.1	Principle.....	8
5.2.2	Test equipment.....	8
5.2.3	Sampling and conditioning.....	8
5.2.4	Test method.....	8
5.2.5	Test report.....	12
5.3	Determination of dimensions of toecap.....	12
5.3.1	Sampling and conditioning.....	12
5.3.2	Test method.....	12
5.3.3	Test report.....	12
5.4	Determination of impact resistance.....	12
5.4.1	Test equipment.....	12
5.4.2	Sampling and conditioning.....	16
5.4.3	Test methods.....	16
5.4.4	Test report.....	18
5.5	Determination of compression resistance.....	18
5.5.1	Test equipment.....	18
5.5.2	Sampling and conditioning.....	18
5.5.3	Test method.....	18
5.5.4	Test report.....	19
5.6	Behaviour of toecaps (thermal and chemical).....	20
5.6.1	Sampling and conditioning.....	20
5.6.2	Behaviour of toecaps (thermal and chemical).....	20
5.7	Determination of leak proofness.....	21
5.7.1	Test equipment.....	21
5.7.2	Sampling and conditioning.....	21
5.7.3	Test method.....	21
5.7.4	Test report.....	21
5.8	Dimensions of perforation resistant inserts.....	21
5.8.1	Sampling and conditioning.....	21
5.8.2	Test method.....	22
5.8.3	Test report.....	22
5.9	Determination of the perforation resistance of footwear with a metallic perforation resistant insert.....	23
5.9.1	Test equipment.....	23
5.9.2	Sampling and conditioning.....	23
5.9.3	Test method.....	24
5.9.4	Test report.....	24

5.10	Determination of the perforation resistance of footwear with a non-metallic perforation resistant insert.....	24
5.10.1	General.....	24
5.10.2	Test equipment.....	24
5.10.3	Sampling and conditioning.....	24
5.10.4	Test method.....	25
5.10.5	Test report.....	27
5.11	Behaviour of perforation resistant inserts (thermal and chemical).....	28
5.11.1	Sampling and conditioning.....	28
5.11.2	Behaviour of perforation resistant inserts (thermal and chemical).....	29
5.11.3	Test report.....	29
5.12	Determination of the flex resistance of perforation-resistant inserts.....	29
5.12.1	Sampling and conditioning.....	29
5.12.2	Test method.....	29
5.12.3	Test report.....	29
5.13	Determination of electrical resistance.....	30
5.13.1	Principle.....	30
5.13.2	Test equipment.....	30
5.13.3	Sampling and conditioning.....	30
5.13.4	Test method.....	31
5.13.5	Test report.....	31
5.14	Determination of footwear slip resistance.....	31
5.14.1	Sampling and conditioning.....	31
5.14.2	Test method.....	31
5.14.3	Test report.....	32
5.15	Determination of insulation against heat.....	32
5.15.1	Test equipment.....	32
5.15.2	Sampling and conditioning.....	33
5.15.3	Test method.....	33
5.15.4	Test report.....	33
5.16	Determination of insulation against cold.....	34
5.16.1	Test equipment.....	34
5.16.2	Sampling and conditioning.....	34
5.16.3	Test method.....	35
5.16.4	Test report.....	36
5.17	Determination of energy absorption of the seat region.....	36
5.17.1	Test equipment.....	36
5.17.2	Sampling and conditioning.....	38
5.17.3	Test method.....	38
5.17.4	Test report.....	38
5.18	Determination of resistance to water for whole footwear: trough test.....	38
5.18.1	Principle.....	38
5.18.2	Test equipment.....	38
5.18.3	Sampling and conditioning.....	39
5.18.4	Test method.....	39
5.18.5	Test report.....	40
5.19	Determination of resistance to water for whole footwear: dynamic test.....	40
5.19.1	Principle.....	40
5.19.2	Test equipment.....	40
5.19.3	Sampling and conditioning.....	40
5.19.4	Test method.....	40
5.19.5	Test report.....	42
5.20	Determination of impact resistance of a metatarsal protection.....	42
5.20.1	Test equipment.....	42
5.20.2	Sampling and conditioning.....	45
5.20.3	Test method.....	46
5.20.4	Test report.....	47
5.21	Determination of the dimension of the ankle protection.....	47

5.21.1	Sampling and conditioning.....	47
5.21.2	Test method.....	47
5.21.3	Test report.....	48
5.22	Determination of the shock absorption capacity of ankle protection materials incorporated into the upper.....	48
5.22.1	Principle.....	48
5.22.2	Test equipment.....	49
5.22.3	Sampling and conditioning.....	50
5.22.4	Test method.....	50
5.22.5	Test report.....	50
5.23	Determination of cutting resistance.....	51
5.23.1	Sampling and conditioning.....	51
5.23.2	Dimension of the cut resistant protective area.....	51
5.23.3	Test method.....	52
5.23.4	Test report.....	52
5.24	Scuff caps.....	52
5.24.1	Sampling and conditioning.....	52
5.24.2	Test method for the abrasion resistance of the scuff caps.....	52
5.24.3	Test report.....	52
5.25	Determination of seam strength.....	53
5.25.1	Sampling and conditioning.....	53
5.25.2	Test method.....	53
5.25.3	Test report.....	53
6	Test methods for upper, lining and tongue.....	53
6.1	Determination of thickness of upper.....	53
6.1.1	Sampling and conditioning.....	53
6.1.2	Test method.....	53
6.1.3	Test report.....	53
6.2	Measurement of the height of the upper.....	53
6.2.1	Sampling and conditioning.....	53
6.2.2	Test method for the complete upper.....	54
6.2.3	Test method for the determination of the area for non-water vapour permeable materials.....	54
6.3	Determination of tear strength of the upper, lining and/or tongue.....	56
6.3.1	Sampling and conditioning.....	56
6.3.2	Test method.....	56
6.3.3	Test report.....	57
6.4	Determination of the tensile properties of the upper material.....	57
6.4.1	Sampling and conditioning.....	57
6.4.2	Test method.....	57
6.4.3	Test report.....	58
6.5	Determination of upper flexing resistance.....	58
6.5.1	Sampling and conditioning.....	58
6.5.2	Test method.....	58
6.5.3	Test report.....	61
6.6	Determination of water vapour permeability (WVP).....	61
6.6.1	Principle.....	61
6.6.2	Sampling and conditioning.....	61
6.6.3	Pre-treatment test method.....	61
6.6.4	WVP measurement.....	61
6.6.5	Test report.....	61
6.7	Determination of water vapour absorption (WVA).....	62
6.7.1	Principle.....	62
6.7.2	Test equipment.....	62
6.7.3	Sampling and conditioning.....	62
6.7.4	Test method.....	62
6.7.5	Test report.....	64
6.8	Determination of water vapour coefficient (WVC).....	64

6.8.1	Calculation of WVC.....	64
6.8.2	Test report.....	64
6.9	Determination of pH value.....	64
6.9.1	Sampling and conditioning.....	64
6.9.2	Test method.....	65
6.9.3	Test report.....	65
6.10	Determination of resistance to hydrolysis of upper.....	65
6.10.1	Sampling and conditioning.....	65
6.10.2	Test method.....	65
6.10.3	Test report.....	65
6.11	Determination of chromium VI content.....	65
6.11.1	Sampling and conditioning.....	65
6.11.2	Test method.....	65
6.11.3	Test report.....	66
6.12	Determination of abrasion resistance of lining and insock.....	66
6.12.1	Principle.....	66
6.12.2	Test equipment.....	66
6.12.3	Sampling and conditioning.....	67
6.12.4	Test method.....	67
6.12.5	Test report.....	68
6.13	Determination of water penetration and water absorption for upper.....	69
6.13.1	Principle.....	69
6.13.2	Test equipment.....	69
6.13.3	Sampling and conditioning.....	69
6.13.4	Test method.....	69
6.13.5	Test report.....	70
7	Test methods for insole, insock and footbed.....	71
7.1	Determination of insole, insock and footbed thickness.....	71
7.1.1	Sampling and conditioning.....	71
7.1.2	Test method.....	71
7.1.3	Test report.....	71
7.2	Determination of water absorption and desorption of insole and/or insock.....	71
7.2.1	Principle.....	71
7.2.2	Test equipment.....	71
7.2.3	Sampling and conditioning.....	72
7.2.4	Test method.....	72
7.2.5	Test report.....	73
7.3	Determination of abrasion resistance of insole.....	73
7.3.1	Principle.....	73
7.3.2	Test equipment.....	73
7.3.3	Sampling and conditioning.....	74
7.3.4	Test method.....	74
7.3.5	Test report.....	75
8	Test methods for outsole.....	75
8.1	General remarks.....	75
8.2	Determination of outsole dimensions.....	75
8.2.1	Sampling and conditioning.....	75
8.2.2	Determination of the cleated area.....	75
8.2.3	Outsole thickness and cleat height.....	76
8.2.4	Determination of cleat design in the waist area.....	78
8.3	Determination of tear strength of outsole.....	79
8.3.1	Sampling and conditioning.....	79
8.3.2	Test method.....	79
8.3.3	Test report.....	79
8.4	Determination of outsole abrasion resistance.....	79
8.4.1	Sampling and conditioning.....	79
8.4.2	Test method.....	79

8.4.3	Test report.....	79
8.5	Determination of footwear rigidity.....	79
8.5.1	Principle.....	79
8.5.2	Test equipment.....	80
8.5.3	Sampling and conditioning.....	80
8.5.4	Test method.....	80
8.5.5	Test report.....	82
8.6	Determination of flexing resistance of outsole.....	82
8.6.1	Principle.....	82
8.6.2	Test equipment.....	82
8.6.3	Sampling and conditioning.....	82
8.6.4	Test method.....	82
8.6.5	Test report.....	84
8.7	Determination of resistance to hydrolysis of outsole.....	84
8.7.1	Sampling and conditioning.....	84
8.7.2	Test method.....	84
8.7.3	Test report.....	84
8.8	Determination of resistance to fuel oil.....	84
8.8.1	Sampling and conditioning.....	84
8.8.2	Test methods.....	85
8.8.3	Test report.....	85
8.9	Determination of resistance to hot contact.....	85
8.9.1	Test equipment.....	85
8.9.2	Sampling and conditioning.....	88
8.9.3	Test methods.....	88
8.9.4	Test report.....	89
Annex A (informative) Assessment of footwear by the laboratory during testing of thermal behaviour.....		90
Annex B (informative) Footwear sizes.....		93
Bibliography.....		94

Indian Standard

PERSONAL PROTECTIVE EQUIPMENT
PART 1 TEST METHODS FOR FOOTWEAR
(*Third Revision*)

1 Scope

This document specifies methods for testing footwear designed as personal protective equipment.

2 Normative references

The following documents are referred to in the text in such a way that some or all of their content constitutes requirements of this document. For dated references, only the edition cited applies.

ISO 34-1:2015, *Rubber, vulcanized or thermoplastic — Determination of tear strength — Part 1: Trouser, angle and crescent test pieces*

ISO 1817:2015, *Rubber, vulcanized or thermoplastic — Determination of the effect of liquids*

ISO 3290-1:2014, *Rolling bearings — Balls — Part 1: Steel balls*

ISO 3376:2020, *Leather — Physical and mechanical tests — Determination of tensile strength and percentage elongation*

ISO 3377-2:2016, *Leather — Physical and mechanical tests — Determination of tear load — Part 2: Double edge tear*

ISO 4045:2018, *Leather — Chemical tests — Determination of pH and difference figure*

ISO 4643:1992, *Moulded plastics footwear — Lined or unlined poly(vinyl chloride) boots for general industrial use — Specification*

ISO 4649:2017, *Rubber, vulcanized or thermoplastic — Determination of abrasion resistance using a rotating cylindrical drum device*

ISO 4674-1:2016, *Rubber- or plastics-coated fabrics — Determination of tear resistance — Part 1: Constant rate of tear methods*

ISO 5403-1:2011, *Leather — Determination of water resistance of flexible leather — Part 1: Repeated linear compression (penetrometer)*

ISO 5423:1992, *Moulded plastics footwear — Lined or unlined polyurethane boots for general industrial use — Specification*

ISO 6487:2015, *Road vehicles — Measurement techniques in impact tests - instrumentation*

ISO 7500-1:2018, *Metallic materials — Calibration and verification of static uniaxial testing machines — Part 1: Tension/compression testing machines — Calibration and verification of the force-measuring system*

ISO 11640:2018, *Leather — Tests for colour fastness — Colour fastness to cycles of to-and-fro rubbing*

ISO 12947-1:1998 + Cor. 1:2002, *Textiles — Determination of the abrasion resistance of fabrics by the Martindale method — Part 1 Martindale abrasion testing apparatus*

ISO 13287:2019, *Personal protective equipment — Footwear — Test method for slip resistance*

ISO 14268:2012, *Leather — Physical and mechanical tests — Determination of water vapour permeability*

ISO 17697:2016, *Footwear — Test methods for uppers, lining and insoles — Seam strength*

ISO 17707:2005, *Footwear — Test methods for outsoles — Flex resistance*

ISO 17075-1:2017, *Leather — Chemical determination of chromium(VI) content in leather — Part 1: Colorimetric method*

ISO 17075-2:2017, *Leather — Chemical determination of chromium(VI) content in leather — Part 2: Chromatographic method*

ISO 20345:2021, *Personal protective equipment — Safety footwear*

ISO 20346:2021, *Personal protective equipment — Protective footwear*

ISO 20347:2021, *Personal protective equipment — Occupational footwear*

ISO 22568-1:2019, *Foot and leg protectors — Requirements and test methods for footwear components — Part 1: Metallic toecaps*

ISO 22568-2:2019, *Foot and leg protectors — Requirements and test methods for footwear component — Part 2: Non-metallic toecaps*

ISO 22568-3:2019, *Foot and leg protectors — Requirements and test methods for footwear components — Part 3: Metallic perforation resistant inserts*

ISO 22568-4:2021, *Foot and leg protectors — Requirements and test methods for footwear components — Part 4: Non-metallic perforation resistant inserts*

ISO 22649:2016, *Footwear — Test methods for insoles and insocks — Water absorption and desorption*

ISO 23529:2016, *Rubber — General procedures for preparing and conditioning test pieces for physical test methods*

ISO 23388:2018, *Protective gloves against mechanical risks*

3 Terms and definitions

For the purposes of this document, the terms and definitions given in ISO 20345, ISO 20346 and ISO 20347 apply.

ISO and IEC maintain terminological databases for use in standardization at the following addresses:

- ISO Online browsing platform: available at <https://www.iso.org/obp>
- IEC Electropedia: available at <https://www.electropedia.org/>

4 General testing parameters

4.1 Sampling

The minimum number of samples to be tested, together with the minimum number of test pieces taken from each sample, shall be in accordance with [Table 1](#).

Wherever possible and necessary to ensure the essential safety requirements, test pieces shall be taken from the whole footwear. This paragraph is applicable to all of [Table 1](#).

Where samples are required from each of three sizes, these shall comprise the smallest, middle and largest size of the footwear under test [indicated as (SML) in [Table 1](#)]. Where [Table 1](#) does not specify (SML) any three sizes of footwear may be used.

If it is not possible to obtain a large enough test piece from the footwear, then a sample of the material from which the component has been manufactured may be used instead. This shall be noted in the test report.

NOTE 1 Footwear sizes are defined in [Annex B](#).

4.2 Conditioning before and during the test

All test pieces shall be conditioned in a standard atmosphere of (23 ± 2) °C and (50 ± 5) % RH for a minimum of 24 h before testing, unless otherwise stated in the test method.

If the test requires a defined condition (temperature (23 ± 2) °C and/or (50 ± 5) % RH), it is mentioned in the test method. Where the testing in conditioned atmosphere is required, the maximum time which shall elapse between removal from the conditioning atmosphere and the start of testing shall not be greater than 10 min, unless otherwise stated in the test method.

4.3 Prerequisites on the testing procedure

When tolerances are not specified in this document (text or figures), a maximum tolerance of ± 10 % shall be applied.

When several test pieces are tested, at least the worst results with regards to the specification shall be reported unless specified in the test method. A result shall be reported for each tested size.

Footwear shall be tested as it is intended to be used, unless otherwise specified in the test method. For instance, if there is a removable insock, it shall remain in place to perform the tests.

For each of the required measurements performed in accordance with this standard, a corresponding estimate of the uncertainty of measurement should be evaluated. One of the following approaches should be used:

- a statistical method, e.g. as given in ISO 5725-2^[3];
- a mathematical method, e.g. as given in ISO/IEC Guide 98-1^[5];
- uncertainty and conformity assessment as given in ISO/IEC Guide 98-4^[6];
- JCGM 100:2008^[7].

4.4 Test report

For each test method, the test report shall contain the following information.

- Name and address of the testing laboratory.
- Date of issue of the test report.
- Reference to this document, i.e. ISO 20344:2021 and the number of the used clause.
- The reference of the sample.
- The results as defined in each test method.
- The measurement uncertainty (when requested by the customer).
- Any deviation from the test method.

Table 1 — Minimum number of samples and test pieces

	Property under test (B = basic requirement, A = additional requirement)	Test only on the final footwear	Subclause reference	Type and number of samples (S-M-L) = Small-Medium-Large sizes	Type and number of test pieces per sample	
Whole footwear	Specific ergonomic features	B	Yes	5.1	3 pairs of footwear in 3 different sizes	1 pair of footwear
	Upper/outsole and sole interlayer bond strength	B	Yes	5.2	3 items of footwear in sizes S-M-L	1 test piece taken each footwear
	Toecap dimensions	B	No	5.3	1 pair of footwear or toecap in sizes (S-M-L)	1 pair of toecaps
	Impact resistance	B	Yes	5.4	3 pairs of footwear in sizes S-M-L	1 pair of footwear
	Compression resistance	B	Yes	5.5	3 pairs of footwear in sizes S-M-L	1 pair of footwear
	Behaviour of toecaps	B	No	5.6	See Tables 4 and 5	
	Leak proofness	B	Yes	5.7	2 items of footwear in different sizes	1 item of footwear
	Dimensions of perforation resistance inserts	A	Yes	5.8	3 pairs of footwear in sizes S-M-L	1 pair of footwear
	Perforation-resistance of footwear including metallic insert	A	Yes	5.9	3 pairs of footwear in sizes S-M-L	1 pair of footwear
	Perforation-resistance of footwear including non-metallic insert	A	Yes	5.10	3 pairs of footwear in sizes S-M-L	1 pair of footwear
	Behaviour of perforation resistant inserts (thermal and chemical)	A	No	5.11	See Tables 6 and 7	
	Flexion resistance of perforation resistant insert	A	No	5.12	3 pairs of inserts in sizes S-M-L	1 pair of inserts
	Electrical resistance	A	Yes	5.13	3 pairs of footwear in sizes S-M-L	1 pair of footwear
	Slip resistance	B	Yes	5.14	3 pairs of footwear in sizes S-M-L	1 pair of footwear
	Insulation against heat	A	Yes	5.15	2 items of footwear in different sizes	1 item of footwear
	Insulation against cold	A	Yes	5.16	2 items of footwear in different sizes	1 item of footwear
	Energy absorption of seat region	A	Yes	5.17	3 pairs of footwear in sizes S-M-L	1 pair of footwear
	Resistance to water: Trough test	A	Yes	5.18	2 pairs of footwear in different sizes	1 pair of footwear
	Resistance to water: Dynamic test	A	Yes	5.19	2 pairs of footwear in different sizes	1 pair of footwear

(*) when the outsole is a pre-moulded component (injected footwear or cemented footwear) the test can be done on the component directly and not on the footwear

Table 1 (continued)

	Property under test (B = basic requirement, A = additional requirement)		Test only on the final footwear	Subclause reference	Type and number of samples (S-M-L) = Small-Medi- um-Large sizes	Type and number of test pieces per sample
	Impact resistance metatarsal protective device	A	Yes	5.20	3 pairs of footwear in sizes S-M-L	1 pair of footwear
	Dimension of the ankle protection	A	Yes	5.21	3 pairs of footwear in sizes S-M-L	2 test pieces (inside/ outside)
	Ankle protection	A	Yes	5.22	3 footwear in sizes S-M-L	For each footwear 2 test pieces (inside/ outside)
	Cut resistance	A	No	5.23	2 samples (perpendicular of each material to be tested)	2 test pieces
	Scuff cap	A	No	5.24	1 scuff cap or material	2 test piece
	Seam strength	B	Yes	5.25	3 items of footwear in different sizes	1 test piece taken from the footwear
Upper, lining and tongue	Thickness	B	No	6.1	3 pairs of footwear in sizes S-M-L	1 test piece
	Height of the upper	B	Yes	6.2	3 pairs of footwear in sizes S-M-L	Item of footwear
	Tear strength	B	No	6.3	3 items of footwear in different sizes leather 3 samples from the material	3 test pieces
	Tensile properties	B	No	6.4	3 items of footwear in different sizes leather 3 samples from the material	3 test pieces
	Flexing resistance	B	Yes	6.5	3 items of footwear in different sizes leather 3 samples from the material	1 test piece
	Water vapour perme- ability	B	yes	6.6	3 items of footwear in different sizes leather 3 samples from the material	1 test piece
	Water vapour absorp- tion	B	Yes	6.7	3 items of footwear in different sizes leather 3 samples from the material	1 test piece
	pH value	B	No	6.9	Each leather	2 test pieces
	Hydrolysis	B	Yes	6.10	3 items of footwear in different sizes	1 test piece
	Chromium VI content	B	No	6.11	Each leather	1 test piece
Abrasion resistance of lining	B	No	6.12	footwear or materials	4 test pieces, wet 4 test pieces, dry	

(*) when the outsole is a pre-moulded component (injected footwear or cemented footwear) the test can be done on the component directly and not on the footwear

Table 1 (continued)

	Property under test (B = basic requirement, A = additional requirement)		Test only on the final footwear	Subclause reference	Type and number of samples (S-M-L) = Small-Medi- um-Large sizes	Type and number of test pieces per sample
	Water penetration and water absorption	A	No	6.13	footwear or materials	3 test pieces
Insole and In- sock	Thickness	B	No	7.1	3 items of footwear in dif- ferent sizes or 3 samples of the relevant compo- nents	1 test piece
	pH value	B	No	6.9	Each leather	1 test piece
	Water absorption and desorption	B	No	7.2	3 items of footwear in dif- ferent sizes or 3 samples of the relevant compo- nents	1 test piece
	Abrasion resistance of insole	B	No	7.3	3 items of footwear in dif- ferent sizes or 3 samples of the relevant compo- nents	1 test piece
	Chromium VI content	B	No	6.11	Each leather	1 test piece
	Abrasion resistance of insock	B	No	6.12	3 items of footwear in dif- ferent sizes or 3 samples of the relevant compo- nents	4 test pieces, wet 4 test pieces, dry
Outsole	Dimensions	B	Yes	8.2	3 footwear in sizes S-M-L	1 test piece
	Tear strength	B	Yes (*)	8.3	3 items of footwear in different sizes	1 test piece
	Abrasion resistance	B	Yes (*)	8.4	3 items of footwear in different sizes	1 test piece
	Rigidity	A	Yes	8.5	1 item of footwear size M	1 test piece
	Flexing resistance	B	Yes	8.6	3 footwear in sizes S-M-L	1 test piece
	Hydrolysis	B	Yes (*)	8.7	3 items of footwear in different sizes	1 test piece
	Resistance to fuel oil	A	Yes (*)	8.8	3 items of footwear in different sizes	2 test pieces
	Resistance to hot contact	A	Yes (*)	8.9	3 items of footwear in different sizes	1 test piece
(*) when the outsole is a pre-moulded component (injected footwear or cemented footwear) the test can be done on the component directly and not on the footwear						

5 Test methods for whole footwear

5.1 Specific ergonomic features

5.1.1 Sampling and conditioning

Preconditioning of the test pieces is not required.

The specific ergonomic features of the footwear shall be assessed by examining the footwear using wear trials on three wearers with different foot sizes (see [Table 1](#)).

5.1.2 Test method

During the trials the wearers, wearing each pair of the correctly fitting footwear, simulate typical tasks likely to be undertaken in general use.

These tasks are:

- walking for 5 min at a speed of approximately 5 km/h;
- climbing (17 ± 3) stairs and descending (17 ± 3) stairs in 1 min maximum;
- kneeling / crouching down (see [Figure 1](#)).

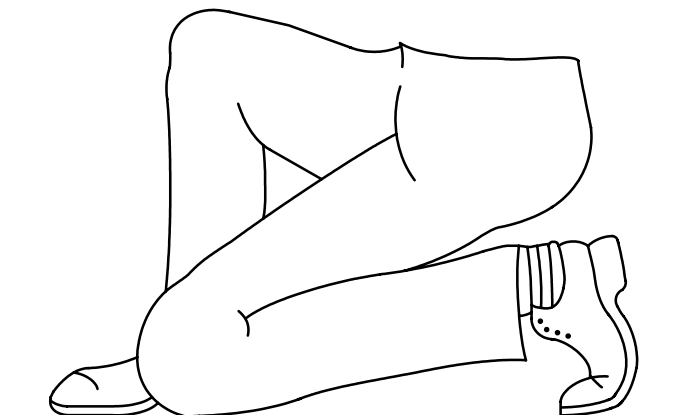

Figure 1 — Position to adopt during the kneel/crouch down test

After having completed all tasks, each wearer shall fill in the questionnaire given in [Table 2](#).

Table 2 — Questionnaire for the assessment of ergonomic features

1	Is the inside surface of the footwear free from rough, sharp or hard areas that caused you irritation or injury (checked by hand)?	YES	NO
2	Is the footwear free of features that you consider make wearing the footwear hazardous? (e.g. buckles, straps or other features that may present a risk of trapping or tripping)	YES	NO
3	Where fastenings are present, can the fastening be adequately adjusted?	YES	NO
4	Can the following activities be performed without problems?		
	4.1 Walking	YES	NO
	4.2 Climbing stairs	YES	NO
	4.3 Kneeling/crouching down	YES	NO

5.1.3 Test report

The following results shall be reported:

- see [4.4](#)
- for each tested size, either all positive answers or any failing result;
- the measurement uncertainty (when requested by the customer).

5.2 Determination of upper/outsole and sole interlayer bond strength

5.2.1 Principle

The force required to separate the upper from the outsole, or to separate adjacent layers of the outsole, or to cause tear failure of the upper or the outsole is measured. The test is not applicable when the bond has been made by grindery (using e.g. nails or screws) or stitching.

NOTE In all cases the objective should be to test the bond strength nearest to the edge of the assembly.

5.2.2 Test equipment

5.2.2.1 Tensile machine

Tensile machine (according to ISO 7500-1:2018, at least class 2), with a means of continuously recording load, with a jaw separation rate of (100 ± 20) mm/min and a force range of 0 N to 600 N. The machine shall be fitted with either pincers or flat jaws (depending on the construction of the test sample, see [5.2.4](#)), at least 25 mm wide, capable of firmly gripping the test pieces.

5.2.3 Sampling and conditioning

For applicable conditioning see [4.2](#).

For sampling see [Table 1](#).

5.2.4 Test method

5.2.4.1 Preparation of test pieces: Sole/upper bond strength: construction type a

Take a test piece from either the inner or the outer flexing area (including the flexing line see [Figure 42](#)). All upper materials in this area shall be tested, see [Figure 2](#).

The sample should not include any part of the scuff cap if present.

Make cuts at X-X and Y-Y at right angles to the edge of the sole, insole or outsole to produce a test piece about 25 mm wide. The length of the upper and sole shall be about 15 mm measured from the feather line (see [Figure 3](#)). Remove the insole.

5.2.4.2 Preparation of test pieces: Sole/upper bond strength: construction types b, c, d and e

Take a test piece from either the inner or the outer flexing area (including the flexing line see [Figure 42](#)). All upper materials in this area shall be tested, see [Figure 2](#).

Cut the upper and sole at X-X and Y-Y to produce a test piece with a width of about 10 mm and a length of not less than 50 mm. Remove the insole.

Separate the upper from the sole for a length of about 10 mm by inserting a hot knife in the adhesive layer (see [Figure 4](#)).

It is considered that a construction is c or d when the distance from X-X to the upper face of the insole is at least 8 mm.

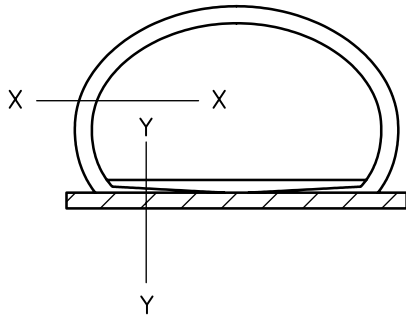

Type a — Conventional lasting, cemented or moulded outsole having an extended range

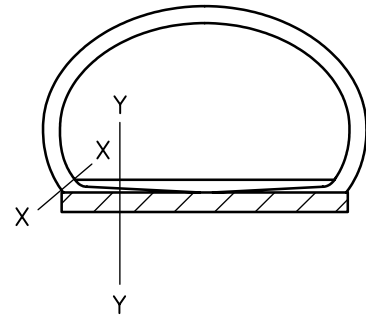

Type b — Conventional lasting, close trimmed outsole

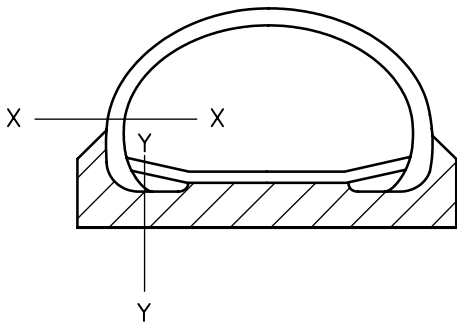

Type c — Conventional lasting, direct injected or vulcanised outsole or cemented dished outsole

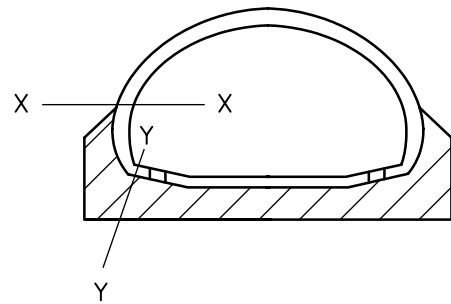

Type d — Strobel stitched, cemented dished outsole or direct injected or vulcanised outsole

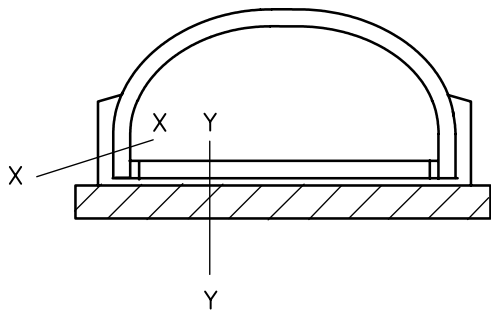

Type e — Conventional lasting or Strobel stitched with rubber mudguard and cemented outsole

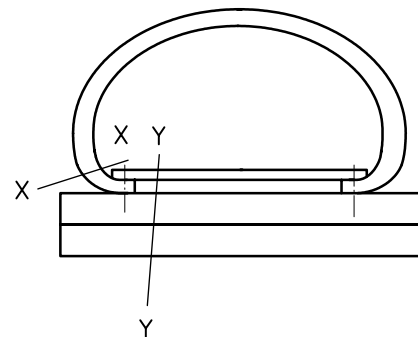

Type f — Machine sewn or welted where the outsole is bonded to the throughsole

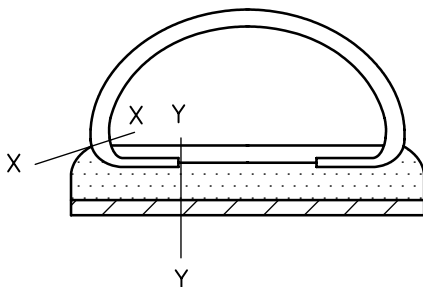

Type g — Multi-layered sole, e.g. moulded-on sole, a moulded unit or a built unit

Figure 2 — Types of construction showing position for preparation of the test piece for bond strength

Dimensions in millimetres

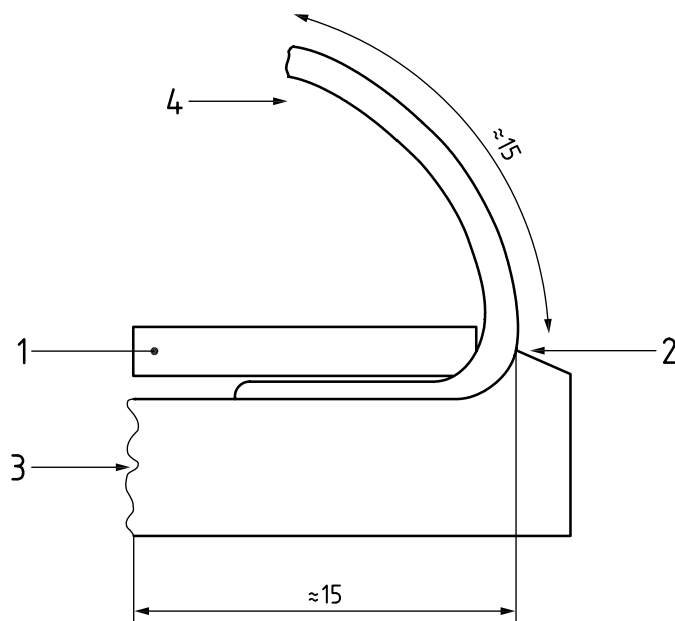

Key

- 1 insole (removed)
- 2 feather line
- 3 outsole
- 4 upper

Figure 3 — Cross section of test piece

Dimensions in millimetres

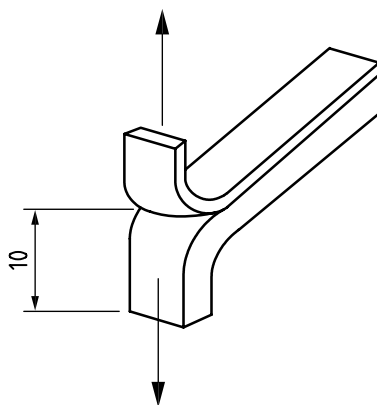

Figure 4 — Prepared test piece

5.2.4.3 Preparation of test pieces: Interlayer bond strength: construction types f and g

Take a test piece from either the inner or the outer flexing area (including the flexing line see [Figure 42](#)). All upper materials in this area shall be tested, see [Figure 2](#).

Remove the upper by cutting along the feather line at X-X. Remove the insole if present. Cut a strip parallel to and including the sole edge at Y-Y to produce a test piece about 15 mm wide and at least 50 mm long. Separate the sole layers for a length of about 10 mm by inserting a hot knife into the adhesive layer (see [Figure 4](#)).

5.2.4.4 Measurement of the bond strength

Before carrying out the test, measure the width of the test piece to the nearest mm at 3 points at least, using a calibrated steel rule and calculate the average value to the nearest mm. Then measure the bond strength on a minimum length of 30 mm in one of the following ways.

- For sole/upper bond strength (construction type a): clamp the test piece into the jaws of the tensile machine, using a pincer jaw to grip the short edge of the sole (see [Figure 5](#)), and record the load/deformation graph (see [Figure 6](#)) at a jaw separation speed of (100 ± 20) mm/min.
- For sole/upper bond strength (construction types b, c, d and e) and sole interlayer bond strength (construction types f and g): clamp the separated ends of the test piece in the flat jaws and record the load/deformation graph (see [Figure 6](#)) at a jaw separation speed of (100 ± 20) mm/min.

Determine, from the load/deformation graph, the average peeling load in newtons and divide by the average width (calculated in [5.2.4](#)) to give the bond strength in N/mm to the nearest 0,1 N/mm.

When there are several materials in the test piece, the result is the average force on the full sample.

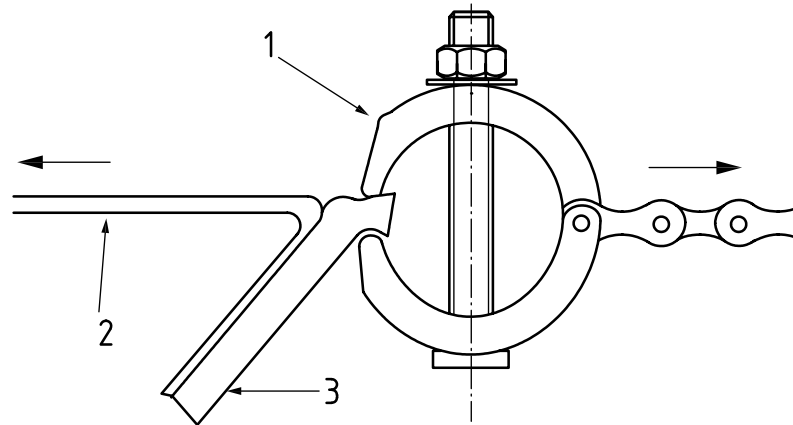

Key

- 1 pincer jaw for sole edge
- 2 upper
- 3 sole

Figure 5 — Pincer jaw showing position of test piece

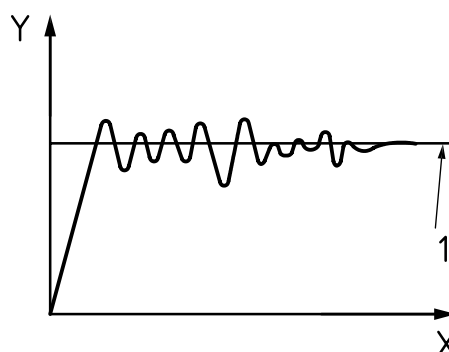

Key

- X deformation
- Y peeling force, expressed in newtons
- 1 average

Figure 6 — Example of load/deformation graph

5.2.5 Test report

The following results shall be reported:

- see [4.4](#)
- the bond strength for each of the 3 tested sizes
- any tearing of the outsole or the upper of the materials (outsole and/or upper).
- the measurement uncertainty (when requested by the customer).

5.3 Determination of dimensions of toecap

5.3.1 Sampling and conditioning

Preconditioning of the test pieces is not required.

For sampling, see [Table 1](#).

5.3.2 Test method

5.3.2.1 Determination of internal toecap length

The internal toecap length shall be determined according ISO 22568-1:2019, 5.2.1 (metallic toe cap) or ISO 22568-2:2019, 5.2.1 (non-metallic toe cap).

5.3.2.2 Determination of toecap flange width

The toecap flange width shall be determined according ISO 22568-1:2019, 5.2.2 (metallic toe cap) or ISO 22568-2:2019, 5.2.2 (non-metallic toe cap).

5.3.3 Test report

The following results shall be reported:

- see [4.4](#);
- internal length for each tested size, left and right;
- flange width for each tested size, left and right;
- the measurement uncertainty (when requested by the customer).

5.4 Determination of impact resistance

5.4.1 Test equipment

5.4.1.1 Impact apparatus, as described in ISO 22568-1:2019, 5.3.1.1

5.4.1.2 Clamping device, consisting of a smooth steel plate at least 19 mm thick and 150 mm × 150 mm, of minimum hardness 60 HRC, with a clamping fork to securely hold the forepart of the footwear under test to the plate. (See [Figures 7](#) and [8](#).)

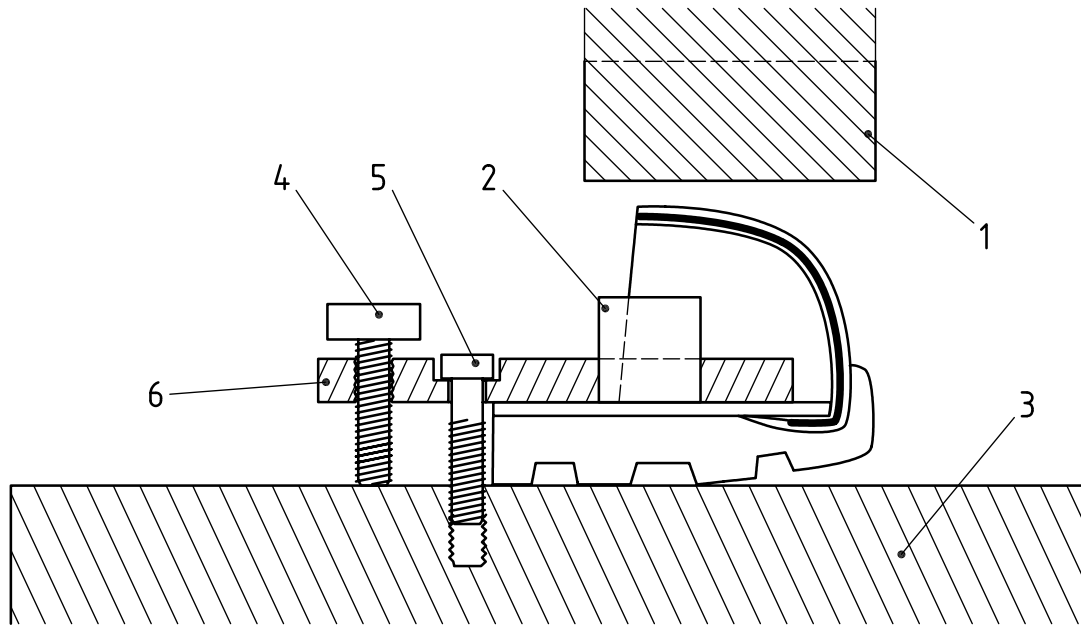

Key

- 1 impact striker
- 2 modelling clay
- 3 impact base plate
- 4 adjusting screw (see [Figure 10](#))
- 5 clamping screw (see [Figure 11](#))
- 6 fork (see [Figure 9](#))

Figure 7 — Test piece position on the testing machine

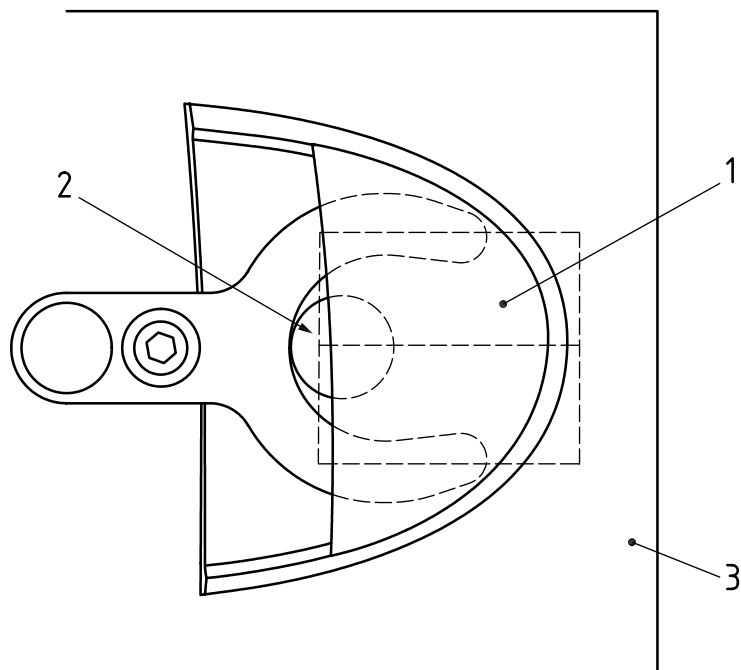

Key

- 1 impact striker
- 2 modelling clay
- 3 impact base plate

Figure 8 — Position of the fork in the test piece

NOTE It is possible to use 2 clamping forks for one the size 41 and bigger, and one smaller for the size lower than 41. An example of the fork dimensions is given in [Figures 9](#).

Dimensions in millimetres

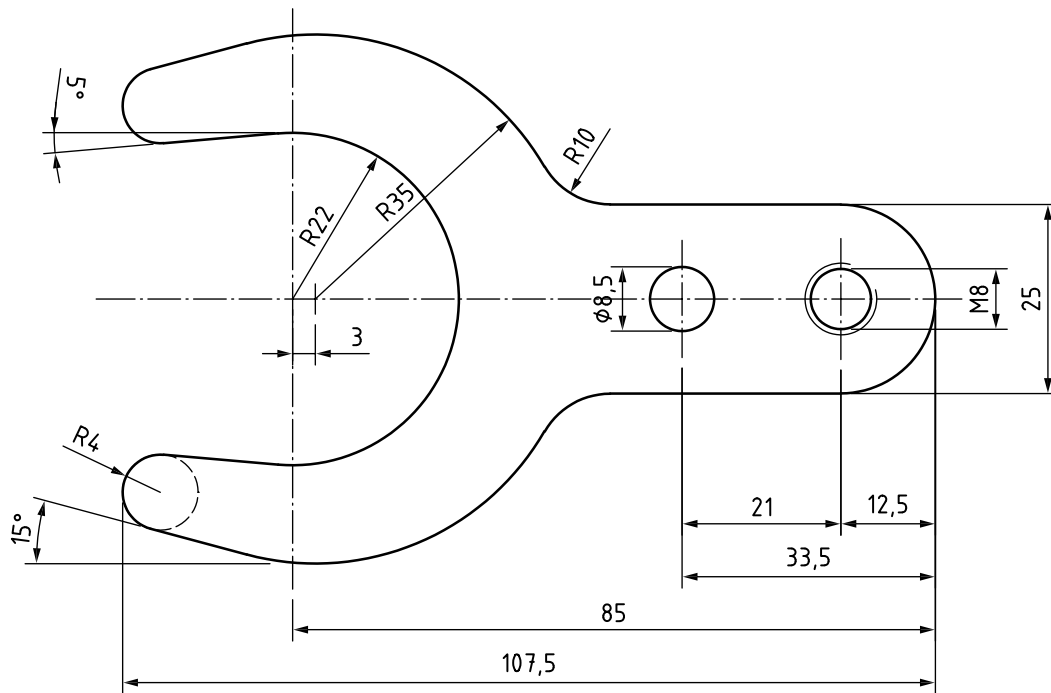

Key

1 thickness approximately 10 mm

Tolerances: $\pm 0,5$ mm and $\pm 2^\circ$

Figure 9 — Example of fork

The clamping fork, which is to be introduced into the front part of the footwear, shall be adjusted by means of the adjusting screw (see [Figure 10](#)) to rest on the insole, parallel to the base plate. The fork shall make light contact with the front wall of the inner surface of the toe cap lining. The clamping screw (see [Figure 11](#)) shall be tightened by applying a torque of (3 ± 1) Nm ensuring that the clamping fork remains parallel with the base plate as judged by eye when tight.

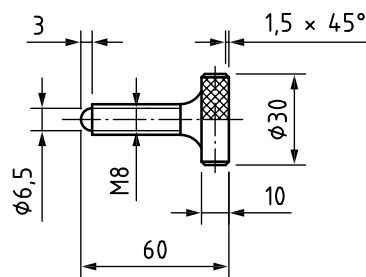

Tolerance $\pm 0,15$ mm

Figure 10 — Example of adjusting screw

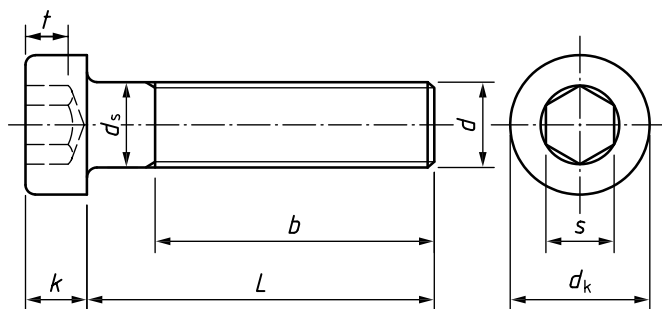

(dimensions see [Table 3](#))

Figure 11 — Example of clamping screw

Table 3 — Dimensions of the clamping screw (see [Figure 11](#))

d	Pitch P	b			dk		k		S			t	
		L<125	125<L<200	L>200	max	min	max	min	Nom	max	min		
M8	1,25	22	28	/	13	12,73	5	4,82	5	5,14	5,02	3,95	3,65

5.4.1.3 Cylinders, of modelling clay of diameter (25 ± 2) mm and of height (20 ± 2) mm for footwear up to and including European size 40 and of height (25 ± 2) mm for footwear above size 40 (see [Annex B](#)). The flat ends of the cylinder shall be covered with aluminium foil to prevent them sticking to either the test piece or the test equipment.

The modelling clay shall fulfil the requirement given in ISO 22568-1:2019, A.2.

5.4.1.4 Dial gauge, with a hemispherical foot of $(3,0 \pm 0,2)$ mm radius and a hemispherical anvil of (15 ± 2) mm radius exerting a force not greater than 0,25 N.

5.4.2 Sampling and conditioning

Preconditioning of the test pieces is not required.

For sampling, see [Table 1](#).

5.4.3 Test methods

5.4.3.1 Determination of the test axis

Locate the testing axis (see [Figure 12](#)) by placing the footwear on a horizontal surface and against a vertical plane so that it touches the edge of the outsole at points A and B on the inner side of the footwear. Construct two further vertical planes at right angles to the first vertical plane so that they meet the outsole at points X and Y, the toe point and heel point respectively. Draw a line through X and Y. This constitutes the test axis for the forepart of the footwear.

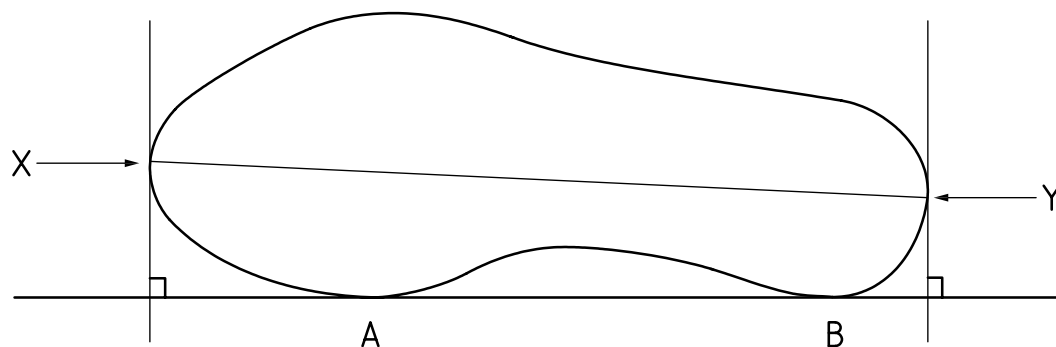
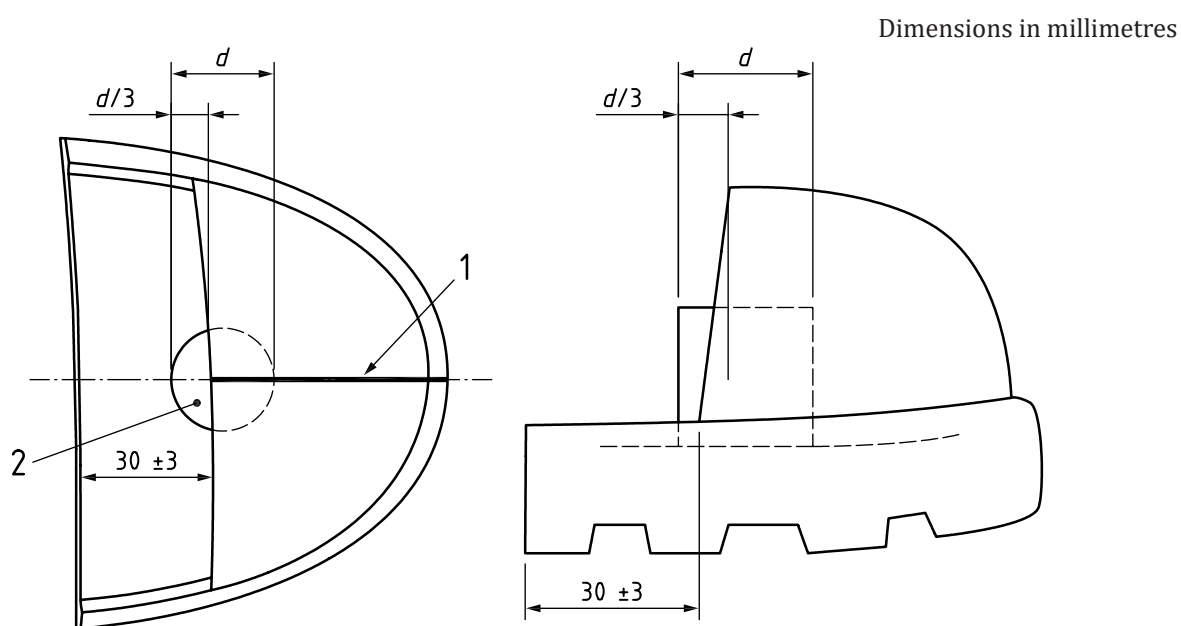

Figure 12 — Test axis for footwear

5.4.3.2 Preparation of the test piece

Prepare the forepart of the footwear by cutting off the toe end (30 ± 3) mm behind the rear edge of the toecap (see Figure 13). Then remove the complete upper assembly flush with the rear edge of the toecap. Do not remove the upper and lining in the toecap area. If the footwear has been supplied with a removable insock, carry out the test with it in place.



Key

- 1 test axis marked on the toe
- 2 modelling clay cylinder

Figure 13 — Prepared toecap end showing the position of the modelling clay cylinder

5.4.3.3 Test procedure

Position a cylinder (5.4.1.3) on one of its ends inside the test piece as shown in Figure 13. The modelling clay cylinder shall be positioned along the test axis of the toe end with $1/3$ of its diameter outside of the toe cap and $2/3$ beneath the cap.

Position the test piece in the impact apparatus (5.4.1.1) so that when the striker hits it, the striker shall project over the back and the front of the toecap. Adjust the clamping device (5.4.1.2), see Figure 7.

Allow the striker to drop on to the test axis from the appropriate height to give an impact energy of (200 ± 4) J for safety footwear or (100 ± 2) J for protective footwear.

The impact energy, E , is given by [Formula \(1\)](#):

$$E = \frac{1}{2}mv^2 \quad (1)$$

where

m is the mass of the striker;

v is the speed of the striker at the impact point.

Therefore the speed is $v = \sqrt{2\frac{E}{m}}$

For safety footwear $E = 200$ J with a mass of $(20 \pm 0,2)$ kg the speed is 4,47 m/s.

For protective footwear $E = 100$ J with a mass of $(20 \pm 0,2)$ kg the speed is 3,16 m/s.

With the measuring device ([5.4.1.4](#)), measure the lowest height to which the cylinder has been compressed to the nearest 0,5 mm. This value is the clearance at the moment of impact.

After the test, the toecap shall be visually inspected to detect any cracks through which it is possible to see light.

5.4.4 Test report

The following results shall be reported:

- see [4.4](#);
- for each tested size, left and right clearance;
- presence of any cracks and their description;
- the measurement uncertainty (when requested by the customer).

5.5 Determination of compression resistance

5.5.1 Test equipment

As described in ISO 22568-1:2019, 5.4.1.

5.5.2 Sampling and conditioning

Preconditioning of the test pieces is not required.

For sampling, see [Table 1](#).

5.5.3 Test method

5.5.3.1 Determination of the test axis

Determine the test axis as described in [5.4.3.1](#).

5.5.3.2 Preparation of the test piece

Prepare the test piece as described in [5.4.3.2](#).

5.5.3.3 Test procedure

Position a cylinder (5.4.1.3) on one of its ends inside the test piece as shown in Figure 13 and 14). Place the test piece in the clamping device (5.4.1.2) and adjust to align the test axis of the test piece with the centre line of the device as scribed on the clamp plate.

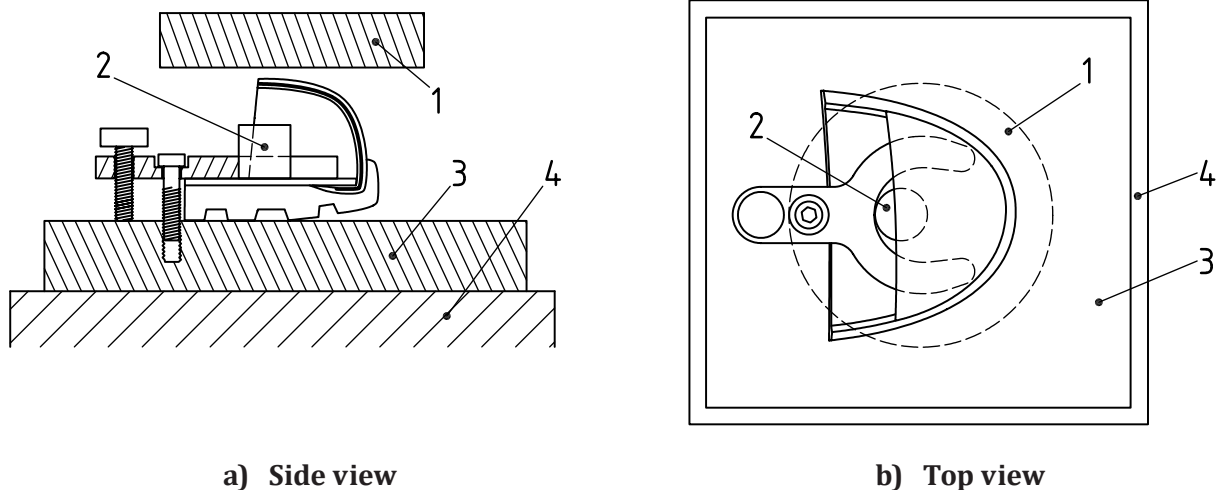

Key

- 1 upper plate
- 2 modelling clay cylinder
- 3 clamping device
- 4 lower plate

Figure 14 — Principle of the apparatus for compression resistance (example of design)

Position the clamping device and test piece between the plates of the compression machine (5.5.1) and compress the test piece until the load of $(15 \pm 0,15)$ kN for safety footwear or $(10 \pm 0,1)$ kN for protective footwear (see Figure 14) has been reached. The centre point of the top compression platen should be located along the test axis marked on the shoe and at the half way point of from front to back of the test piece as judged by eye.

Reduce the load, remove the cylinder and, with the measuring device (5.5.1), measure the lowest height to which the cylinder has been compressed to the nearest 0,5 mm. This value is the compression clearance.

After the test, the toecap shall be visually inspected to detect any cracks through which it is possible to see light.

5.5.4 Test report

The following results shall be reported:

- see 4.4;
- for each tested size, left and right clearance;
- presence of any cracks and their description;
- the measurement uncertainty (when requested by the customer).

5.6 Behaviour of toecaps (thermal and chemical)

5.6.1 Sampling and conditioning

Preconditioning of the test pieces is not required.

For sampling, see [Table 4](#).

Table 4 — Minimum number of samples for toe caps

Footwear	Type and number of samples	Type and number of test pieces per sample	Test only on the final footwear
Class I metal toecap (corrosion) and Hybrid mounted footwear	1 toecap in 2 sizes	1 toecap	No
Class II metal toecap (corrosion) and Hybrid moulded footwear	1 shoe in 2 sizes	1 shoe	Yes
Class I, II and hybrid footwear non-metal toecap (thermal and chemical behaviour)	3 pairs of toecaps	1 pair of toecaps for each of the 3 treatments	No

5.6.2 Behaviour of toecaps (thermal and chemical)

Toecaps shall be tested in accordance with [Table 5](#).

Table 5 — Test method for toe caps

Footwear	Test method
Class I metal toecap (corrosion) and Hybrid mounted footwear	ISO 22568-1:2019, 5.5
Class II metal toecap (corrosion) and Hybrid moulded footwear	5.6.2.1
Class I, II and hybrid footwear non-metal toecap (thermal and chemical behaviour)	ISO 22568-2:2019, 5.5.2, 5.5.3, 5.5.4

5.6.2.1 Test method for the corrosion test of metallic toe cap in class II and hybrid moulded footwear

5.6.2.1.1 Test solution

Use a mass fraction of 1 % aqueous solution of sodium chloride.

5.6.2.1.2 Procedure

Pour sufficient test solution into a test piece to fill it up in order to be sure that the toecap is under the level of the solution. Cover the top of the footwear with e.g. a polyethylene cover, to minimise evaporation.

Leave for 7 days and then discard the test solution.

Remove the toecap from the footwear and examine for any evidence of corrosion. When present, measure the longest distance across each area of corrosion and note the number of such areas.

5.6.2.1.3 Test report

The following results shall be reported:

- see [4.4](#);
- number of corroded area(s) and size of each corroded area;
- the measurement uncertainty (when requested by the customer).

5.7 Determination of leak proofness

5.7.1 Test equipment

5.7.1.1 Water bath

5.7.1.2 Supply of compressed air

5.7.1.3 **Pressure sensor**, with an accuracy 1 kPa or better.

5.7.1.4 **Stopwatch**, with an accuracy ± 1 s.

5.7.2 Sampling and conditioning

Preconditioning of the footwear is not required.

For sampling see [Table 1](#).

5.7.3 Test method

Take the entire item of footwear as the test piece and carry out the test at a temperature of (23 ± 2) °C.

Seal the top edge of the test piece, e.g. with a rubber collar through which compressed air may be fed via appropriate connections. Immerse the test piece in a water bath up to the edge and apply a constant internal pressure of (30 ± 5) kPa for (30 ± 5) s. Observe the test piece throughout the test and determine whether there is a continued formation of air bubbles, indicating leakage of air.

5.7.4 Test report

The following results shall be reported:

- see [4.4](#);
- for each tested size, detection of air leakage;
- the measurement uncertainty (when requested by the customer).

5.8 Dimensions of perforation resistant inserts

5.8.1 Sampling and conditioning

Preconditioning of the test pieces is not required.

For sampling, see [Table 1](#).

5.8.2 Test method

Split the sole so that the full perforation resistant insert can be seen. Record any holes, their position and their diameter.

Measure L , the length of the inside of the bottom of the footwear. Draw as in [Figure 15](#) the shaded areas 1 and 2.

Section the footwear and measure the distances X and Y (see [Figure 15](#)) being the distances between the edge of the insert and the line left by the feather edge of the last, to the nearest 0,5 mm.

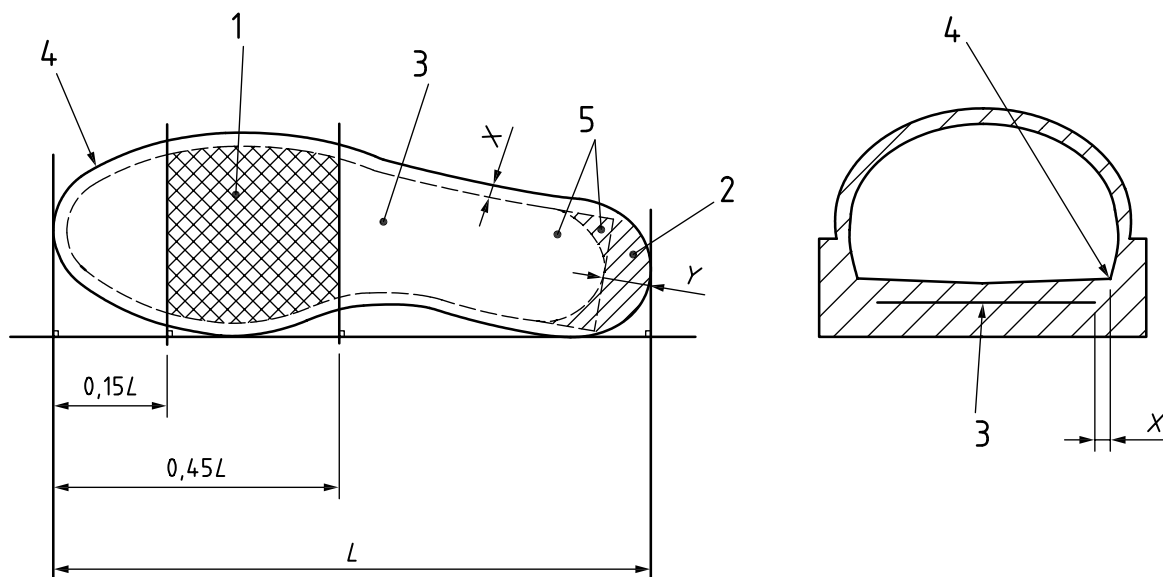

Key

- 1 shaded area 1
- 2 shaded area 2
- 3 insert
- 4 line left by feather edge of the last
- 5 alternative shapes of insert
- L length of the inside of the bottom of the footwear
- XY distances to be measured

Figure 15 — Determination of dimensions for the insert

5.8.3 Test report

The following results shall be reported:

- see [4.4](#);
- for each tested size, left and right:
 - the maximum distances for both X and Y ;
 - presence of holes, their number, positions and diameter;
 - the measurement uncertainty (when requested by the customer).

5.9 Determination of the perforation resistance of footwear with a metallic perforation resistant insert

5.9.1 Test equipment

5.9.1.1 Apparatus capable of measuring a compressive force up to at least 2 000 N (according to ISO 7500-1:2018, at least class 2), fitted with a pressure plate, in which a test nail (5.9.1.2) is fixed, and a parallel plate with a circular opening of diameter $(25 \pm 0,2)$ mm. The axes of this opening and the test nail shall be concentric (see Figure 16).

Dimensions in millimetres

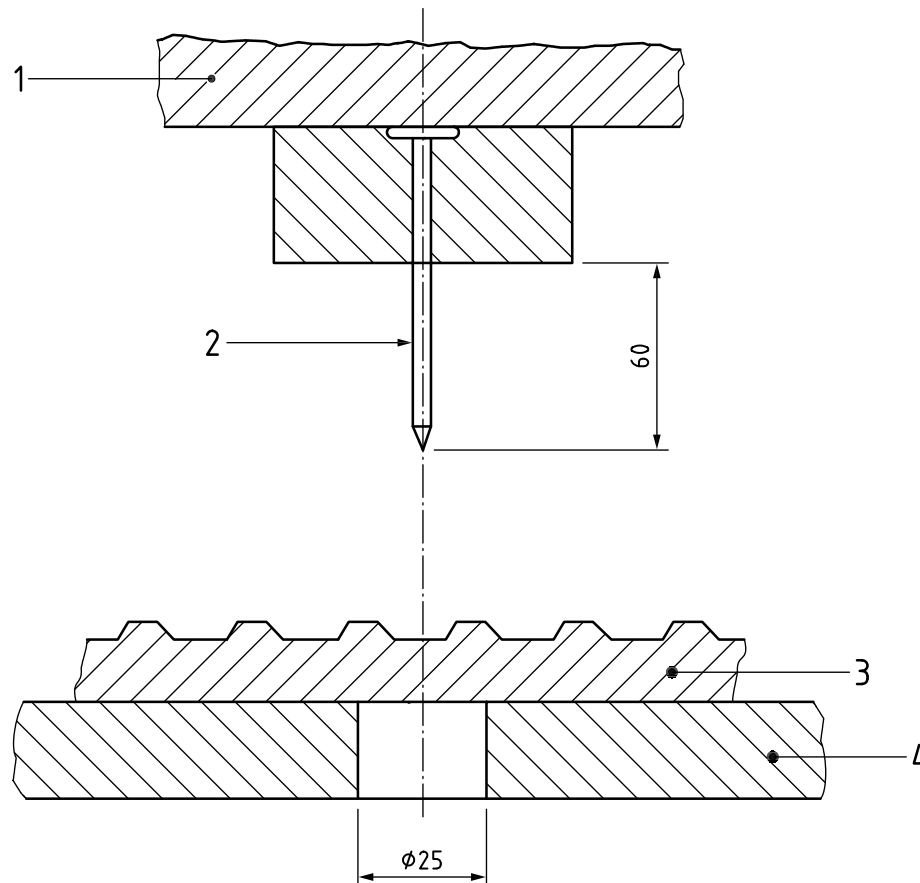

Key

- 1 pressure plate
- 2 test nail
- 3 sole unit of the test piece
- 4 plate

Figure 16 — Example of an apparatus for perforation resistance test of a footwear with a metallic insert

5.9.1.2 Test nail, as described in ISO 22568-3:2019, 5.1.1.3.

5.9.2 Sampling and conditioning

Preconditioning of the test pieces is not necessary, except for water-absorbent soles. For sampling, see Table 1.

5.9.3 Test method

5.9.3.1 Preparation of the test piece

Remove the upper from the bottom of the footwear and use the bottom as the test piece.

For absorbent soling material (e.g. leather) carry out the tests after the sole unit has been immersed in deionised water at (23 ± 2) °C for (16 ± 1) h.

5.9.3.2 Test procedure

Place the test piece on the plate in such a way that the test nail can penetrate it through the bottom. Press the nail against the sole unit at a speed of (10 ± 3) mm/min until the point has penetrated completely and measure the maximum force.

Carry out the test at four different points on the sole unit (at least one in the heel region) with a minimum distance of 30 mm between any two perforation points and a minimum distance of 10 mm from the edge of the insole. For cleated outsoles, carry out the test between cleats. Two of the four measurements shall be made at a distance of 10 mm to 15 mm from the line represented by the feather edge of the last.

For each footwear, the result is the lowest value of the 4 tests.

5.9.4 Test report

The following results shall be reported:

- see [4.4](#);
- for each tested size, left and right, the lowest value of the maximum force;
- the measurement uncertainty (when requested by the customer).

5.10 Determination of the perforation resistance of footwear with a non-metallic perforation resistant insert

5.10.1 General

Depending on the type of the non-metallic perforation-resistant insert (see ISO 22568-4:2021, 4.2), choose the appropriate test method, [5.10.4.2.1](#) or [5.10.4.2.2](#).

5.10.2 Test equipment

5.10.2.1 Apparatus, see [5.9.1.1](#)

5.10.2.2 Test nail for type PS, as described in ISO 22568-4:2021, B.1.2.

5.10.2.3 Test nail for Type PL, as described in ISO 22568-4:2021, A.1.2.

5.10.3 Sampling and conditioning

Preconditioning of the test pieces is not necessary, except for water-absorbent soles. For sampling, see [Table 1](#).

5.10.4 Test method

5.10.4.1 Preparation of the test piece

Remove the upper from the bottom of the footwear and use the bottom as the test piece.

If the non-metallic perforation-resistant insert type PL is not visible or not used as an insole (e.g. in a Stroebel), the test shall be conducted in accordance [5.9.3](#)

If the non-metallic perforation-resistant insert incorporates stitches associated with antistatic properties, one of the perforations at least shall be performed in this area.

For absorbent soling material (e.g. leather) carry out the tests after the sole unit has been immersed in deionised water at (23 ± 2) °C for (16 ± 1) h.

5.10.4.2 Test procedure

5.10.4.2.1 For type PS

Apparatus capable of measuring a compressive force up to at least 2 000 N (according to ISO 7500-1:2018, at least class 2), fitted with a pressure plate, in which a test nail ([5.10.2.2](#)) is fixed, and a parallel plate with a circular opening of diameter $(40 \pm 0,3)$ mm. The axes of this opening and the test nail shall be concentric (see [Figure 17](#)).

Dimensions in millimetres

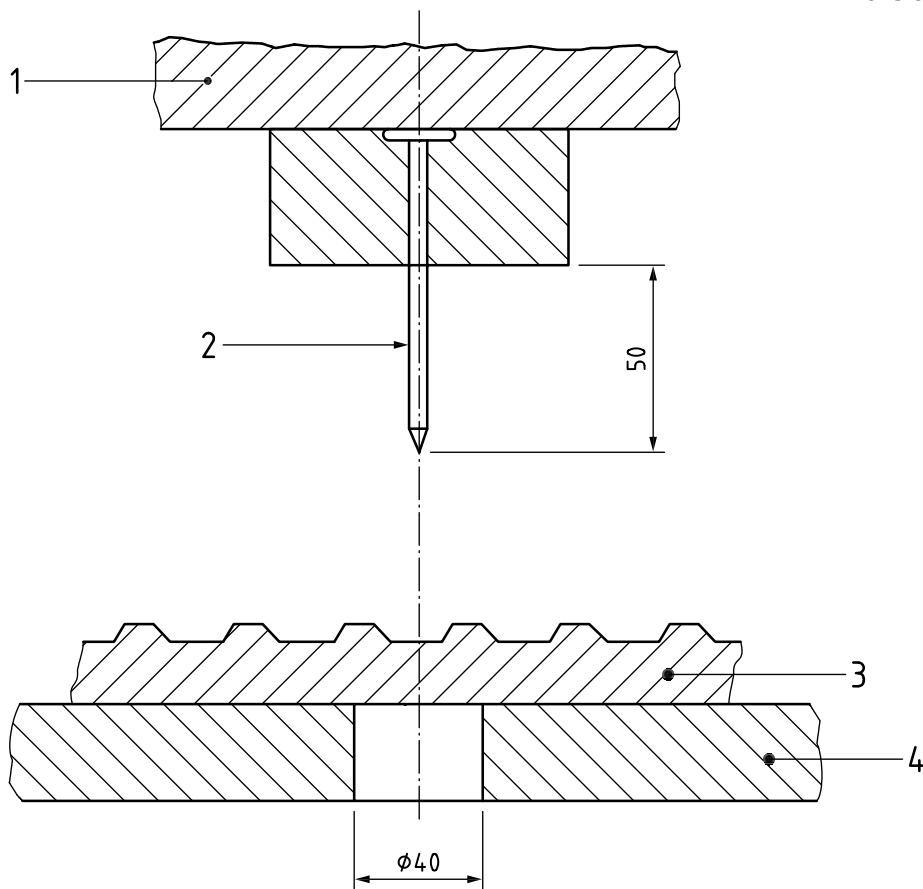

Key

- 1 pressure plate
- 2 test nail
- 3 sole unit of the test piece
- 4 plate

Figure 17 — Example of an apparatus for perforation resistance test of a footwear with a non-metallic insert type PS

Place the test piece on the plate in such a way that the test nail can penetrate it through the bottom. Press the nail against the sole unit at a speed of (10 ± 3) mm/min until the point has penetrated completely and measure the maximum force.

Carry out the test at four different points on the sole unit (at least one in the heel region) with a minimum distance of 30 mm between any two perforation points and a minimum distance of 10 mm from the edge of the insole. For cleated outsoles, carry out the test between cleats. Two of the four measurements shall be made at a distance of 10 mm to 15 mm from the line represented by the feather edge of the last.

For each footwear, the result is the average of the 4 values of maximum force.

For each footwear, the 4 single values of maximum force and the average value shall be reported

5.10.4.2.2 For type PL

Place the test piece on the plate (see [Figure 18](#)) in such a way that the test nail ([5.10.2.3](#)) can penetrate it from the tread side.

Run the testing machine at a speed of (10 ± 3) mm/min up to the required force of 1 100 N, then stop the machine and carry out either the visual inspection within 10 s at an angle of $90^\circ \pm 15^\circ$ to the nail axis or an electrical or cinematographic detection. If the opposite surface of the test piece has been perforated, the test piece has failed the test. Register If separation between the layers of the test piece occurs (“tent effect”)

Carry out the test at four different points on the sole unit (at least one in the heel region) with a minimum distance of 30 mm between any two perforation points and a minimum distance of 10 mm from the edge of the insole. For cleated outsoles, carry out the test between cleats. Two of the four measurements shall be made at a distance of 10 mm to 15 mm from the line represented by the feather edge of the last.

For each footwear, the 4 results shall be reported.

5.10.5 Test report

The following results shall be reported:

- see [4.4](#);
- for each tested size, left and right, results of [5.10.4.2.1](#) or [5.10.4.2.2](#).
- Note any “tent effect”;
- The measurement uncertainty (when requested by the customer).

Dimensions in millimetres

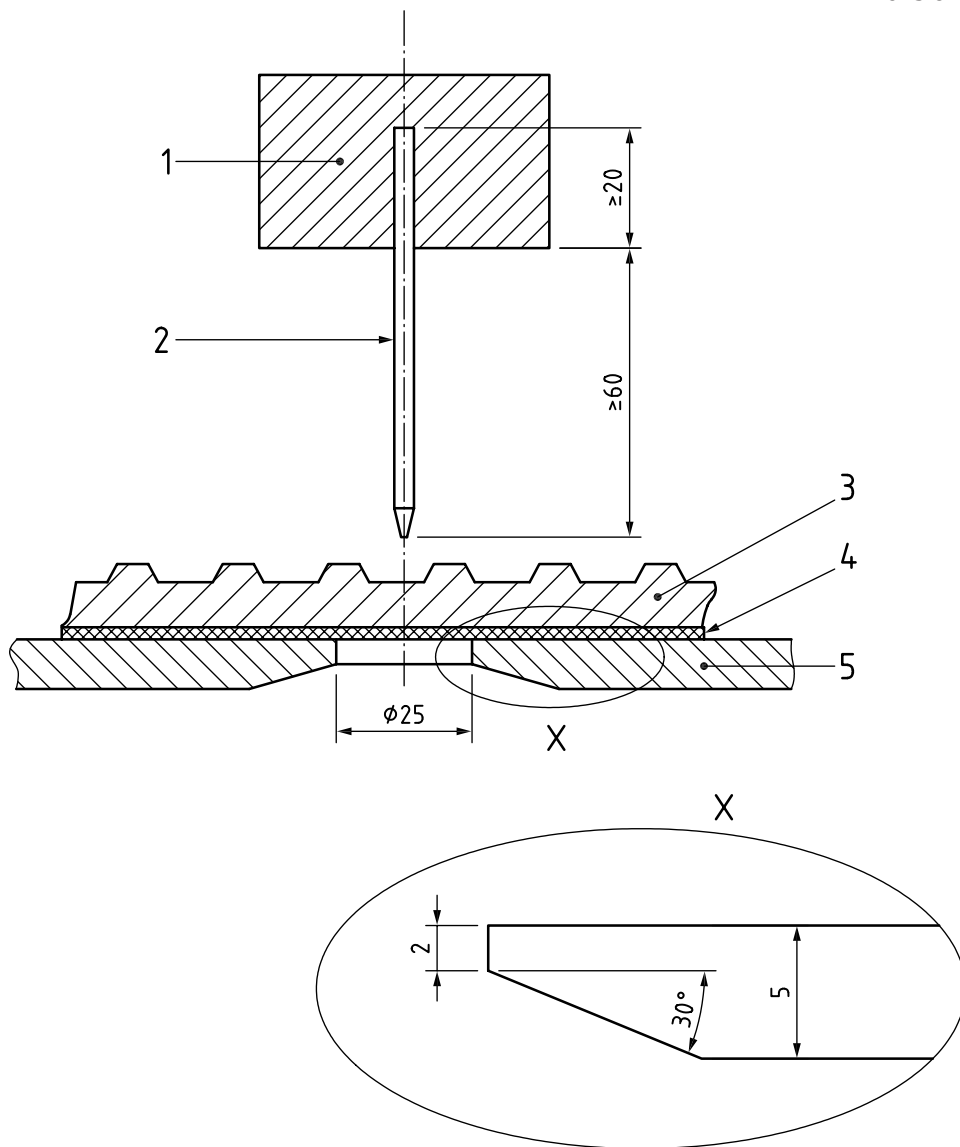

Key

- 1 nail clamping system
- 2 nail
- 3 sole unit of the test piece
- 4 perforation resistant insert
- 5 plate

Figure 18 — Example of an apparatus for perforation resistance test of a footwear with a non-metallic insert type PL

5.11 Behaviour of perforation resistant inserts (thermal and chemical)

5.11.1 Sampling and conditioning

Preconditioning of the test pieces is not required.

For sampling, see [Table 6](#).

Table 6 — Minimum number of samples for perforation resistant insert

Footwear and perforation resistant insert	Type and number of samples	Type and number of test pieces per sample	Test only on the final footwear
Class I footwear and Hybrid mounted footwear with metallic perforation resistant inserts (corrosion)	1 insert in 2 sizes	1 insert	No
Class II footwear and Hybrid moulded footwear with metallic perforation resistant inserts (corrosion)	1 shoe in 2 sizes	1 shoe	Yes
All footwear types with non-metallic perforation resistant inserts or insoles (thermal and chemical behaviour)	4 inserts	1 insert for each of the 4 treatments	No

5.11.2 Behaviour of perforation resistant inserts (thermal and chemical)

Perforation resistant inserts shall be tested in accordance with [Table 7](#).

Table 7 — Test method for perforation resistant insert

Footwear and perforation resistant insert	Test method
Class I footwear and Hybrid mounted footwear with metallic perforation resistant inserts (corrosion)	ISO 22568-3:2019, 5.3
Class II footwear and Hybrid moulded footwear with metallic perforation resistant inserts (corrosion)	5.6.2.1
All footwear types with non-metallic perforation resistant inserts	ISO 22568-4:2021, 5.3.2, 5.3.3, 5.3.4, 5.3.5

5.11.3 Test report

The following results shall be reported:

- see [4.4](#);
- all results as defined in the relevant used standard;
- the measurement uncertainty (when requested by the customer).

5.12 Determination of the flex resistance of perforation-resistant inserts

5.12.1 Sampling and conditioning

For applicable conditioning, see [4.2](#).

For sampling, see [Table 1](#).

5.12.2 Test method

Determine the flex resistance of perforation-resistant inserts in accordance with ISO 22568-3:2019, 5.2 (metallic insert) or ISO 22568-4:2021, 5.2 (non-metallic insert).

5.12.3 Test report

The following results shall be reported:

- see [4.4](#);
- all results as defined in the relevant used standard;
- the measurement uncertainty (when requested by the customer).

5.13 Determination of electrical resistance

5.13.1 Principle

The electrical resistance of partially conductive footwear is measured after conditioning in a dry atmosphere (5.13.3.2 a)). The electrical resistance of antistatic footwear is measured after conditioning in a dry atmosphere and afterwards conditioning in a wet atmosphere (5.13.3.2 a) and b)). If there are enough samples, the two conditionings can be conducted in parallel.

5.13.2 Test equipment

5.13.2.1 Testing instrument, capable of measuring electrical resistance to an accuracy of $\pm 2,5$ % while applying a voltage of (100 ± 2) V DC.

5.13.2.2 Internal electrode, comprising stainless steel balls of 5 mm diameter and of total mass $(4 \pm 0,1)$ kg. The steel balls shall conform to the requirements of ISO 3290-1:2014. The balls are connected to the testing instrument using a copper cable. A good contact shall be obtained by using a square end of at least 2 cm^2 . Steps should be taken to prevent or remove oxidation of the steel balls and the copper plate since oxidation could affect their conductivity.

5.13.2.3 External electrode, comprising a copper contact plate cleaned with ethanol before use.

5.13.2.4 Conductive lacquer, having a resistance of less than $1 \times 10^3 \Omega$.

5.13.2.5 Device for measuring the conductive resistance of the lacquer, consisting of three conductive metal probes, each $(3 \pm 0,2)$ mm radius, attached to an electrical insulating base plate. Two of the probes are (45 ± 2) mm apart and connected by a metal strap. The third probe is set at a distance of (180 ± 5) mm from the centre line joining the other two and is electrically insulated from them.

5.13.3 Sampling and conditioning

For sampling, see [Table 1](#).

5.13.3.1 Preparation for conditioning of the test piece

5.13.3.1.1 Preparation

If the footwear has been supplied with a removable insock, carry out the test with it in place. Clean the surface of the outsole of the footwear with ethanol to eliminate all traces of mould silicone, wash with distilled water and allow drying at (23 ± 2) °C. The surface shall not be buffed or abraded or cleaned with organic materials which attack or swell the outsole.

5.13.3.1.2 Specific preparation for conditioning under wet conditions

For test pieces (only for antistatic footwear) which are tested following conditioning under wet conditions (see 5.13.3.2), apply a conductive lacquer (5.13.2.4) to the outsole over an area (200 ± 5) mm by (50 ± 5) mm, including the heel and the fore part. Allow to dry and then check that the resistance of the lacquer is less than $1 \times 10^3 \Omega$.

After conditioning, fill the footwear with clean steel balls (5.13.2.2) and place on the metal probes of the device (5.13.2.5) such that the front area of the outsole is supported by the two probes spaced (45 ± 5) mm apart and the heel area is supported by the third probe. Using the testing instrument (5.13.2.1), measure the resistance between the front probes and the third probe.

5.13.3.2 Conditioning

Condition the prepared test piece in one of the following atmospheres, according to the type of footwear being tested:

- a) dry conditions — (20 ± 2) °C and (30 ± 5) % RH (for 7 days);
- b) wet conditions — (20 ± 2) °C and (85 ± 5) % RH (for 7 days).

The test shall be started within 5 min of the removal of the test piece from the conditioning atmosphere (dry and wet).

5.13.4 Test method

The tests shall be carried out in a standard atmosphere of (23 ± 2) °C and (50 ± 5) % RH.

Fill the test piece with clean steel balls to a total mass of $(4 \pm 0,1)$ kg using a piece of insulating material to extend the height of the upper if necessary. Place the filled test piece on the copper plate, apply a test voltage of (100 ± 2) V DC between the copper plate and the steel balls for 1 min and measure the resistance.

The energy dissipation in the sole shall not be greater than 3 W.

Wherever necessary, reduce the voltage in order to respect the 3 W limit and record the voltage value in the test report.

5.13.5 Test report

The following results shall be reported:

- see [4.4](#);
- for each tested size, left and right, the footwear resistance for each test conditioning;
- the measurement uncertainty (when requested by the customer).

5.14 Determination of footwear slip resistance

5.14.1 Sampling and conditioning

For applicable conditioning, see [4.2](#).

For sampling, see [Table 1](#).

5.14.2 Test method

The tests shall be carried out in a standard atmosphere of (23 ± 2) °C.

The coefficient of friction of the footwear is determined in accordance with ISO 13287:2019 under the test conditions given in [Table 8](#).

The cleaning procedure described in ISO 13287:2019, 7.1.4.2 shall not be carried out.

Table 8 — Test conditions for slip resistance

Conditions	Floor	Lubricant
A (forward heel slip)	Ceramic tile(s)	Sodium lauryl sulphate
B (backward forepart slip)		
C (forward heel slip)	Ceramic tile(s)	Glycerine
D (backward forepart slip)		

5.14.3 Test report

The following results shall be reported:

- see 4.4;
- all results as defined in the relevant used standard;
- the measurement uncertainty (when requested by the customer).

5.15 Determination of insulation against heat

5.15.1 Test equipment

5.15.1.1 Sand bath, the size of the bath holding the sand shall be (40 ± 2) cm \times (40 ± 2) cm with a height of at least 5 cm (see Figure 19).

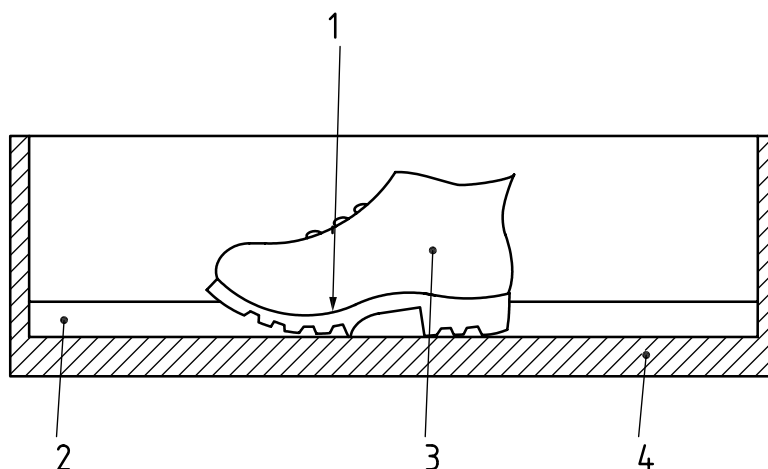

Key

- 1 point for measuring temperature
- 2 sand bath (height of sand approximately 30 mm)
- 3 footwear filled with stainless steel balls
- 4 hotplate

Figure 19 — Heat insulation test apparatus

The volume of sand shall be $(5\,000 \pm 250)$ cm³, with a granular size of 0,3 mm to 1,0 mm.

The temperature of the plate shall be measured where the footwear will contact the plate (forepart and heel) and shall be regulated according to the test temperature. Two parameters are defined in the requirements of the product standards:

- the temperature of the plate, T_{hp}

— the contact time.

The power of the heating system should be at least $(2\ 500 \pm 250)$ W.

5.15.1.2 Thermal transfer medium, comprising stainless steel balls with 5 mm diameter and a total mass of $(4 \pm 0,1)$ kg.

The stainless steel balls shall conform to the requirements of ISO 3290-1:2014.

5.15.1.3 Temperature probe, with an accuracy of $\pm 0,5$ °C, soldered to a copper disc $(2 \pm 0,1)$ mm thick and (15 ± 1) mm diameter.

5.15.1.4 Temperature measuring device, with a compensator, suitable for use with the temperature probe.

5.15.2 Sampling and conditioning

For applicable conditioning, see [4.2](#).

For sampling, see [Table 1](#).

5.15.3 Test method

5.15.3.1 Preparation of the test piece

Use the complete item of footwear as the test piece. Fix the temperature probe to the insole or insock, if present.

The temperature inside the footwear shall be measured in the forepart in an area directly above the area where the outsole contacts the hot plate. Place the steel balls inside the footwear. If the upper is not high enough to support the balls, increase its height with a collar.

5.15.3.2 Test procedure

Preheat the sand bath for 2 h minimum and adjust the temperature of the hot plate to T_{hp} maintain this temperature during the test. Record the initial temperature, T_i . Place the test piece on it. Move the footwear forward and backward in order to get the best possible contact between the footwear and the hot plate.

Place the sand around the footwear at the correct height. Then ensure that the surface of the sand is homogeneously flat. The temperature of the laboratory shall be (25 ± 5) °C.

Use the temperature measuring device connected to the temperature probe to measure the temperature on the insole as a function of time. Record the final temperature, T_f after an appropriate time given in the requirement of the product standard. Temperatures are measured to the nearest 0,5 °C.

Continue the test until the appropriate times given in the requirement of the product standard have been reached. Remove the sample and the steel balls for inspection and note signs of serious damage that affects the functionality of the footwear, applying [Annex A](#). In case of doubt about the right functionality of the footwear, carry out an abrasion resistance of the outsole in accordance with [8.4](#).

If required by the relevant product standard, calculate the increase of temperature, $T_d = T_f - T_i$, after a defined time;

5.15.4 Test report

The following results shall be reported:

— see [4.4](#);

- for each tested size:
 - T_{hp} ;
 - testing time;
 - T_d , if required by the relevant product standard;
 - the final temperature, T_f , after a defined time; if required by the relevant product standard;
 - the description of any damage that can seriously affect the functionality of the footwear (e.g. beginning of separation of upper and sole) applying [Annex A](#) or any other requirement of other standard (for example EN 15090:2012);
 - the measurement uncertainty (when requested by the customer).

5.16 Determination of insulation against cold

5.16.1 Test equipment

5.16.1.1 Insulated cold box, the internal air temperature of which can be regulated to (-17 ± 2) °C (see [Figure 20](#)).

5.16.1.2 Thermal transfer medium, as described in [5.15.1.2](#).

5.16.1.3 Temperature probe, as described in [5.15.1.3](#).

5.16.1.4 Temperature measuring device, as described in [5.15.1.4](#).

5.16.1.5 Copper plate, of length (350 ± 5) mm, width (150 ± 1) mm and thickness $(5 \pm 0,1)$ mm, positioned as illustrated in [Figure 20](#).

5.16.2 Sampling and conditioning

For applicable conditioning, see [4.2](#).

For sampling, see [Table 1](#).

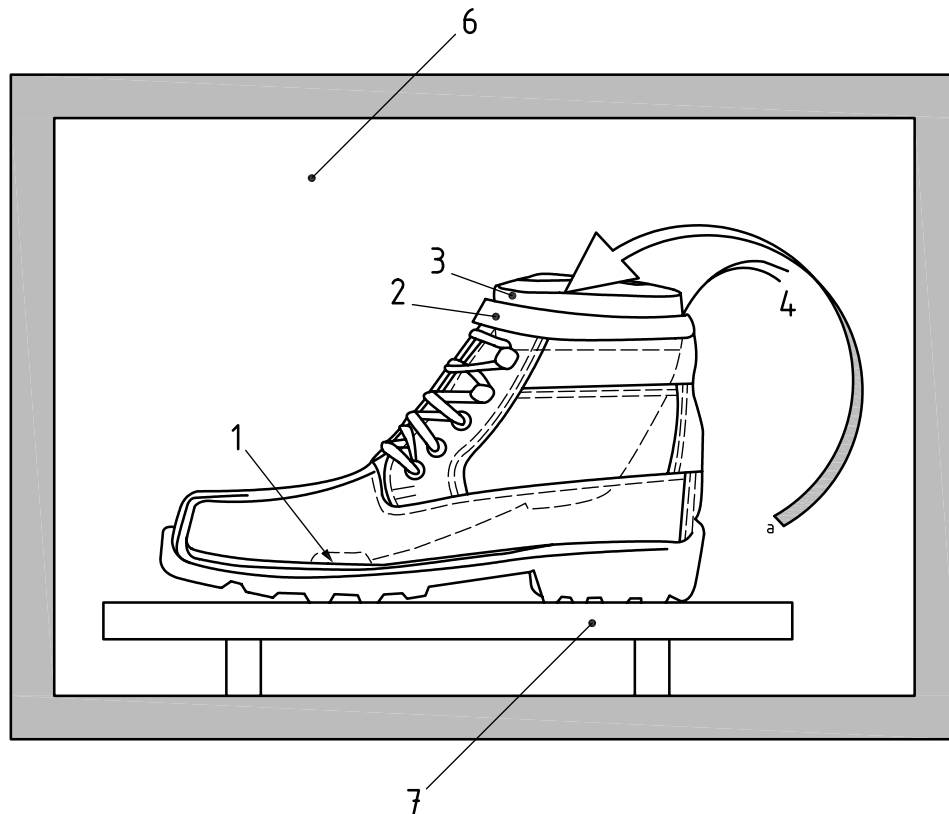

Key

- 1 point to measure temperature
- 2 tape
- 3 closing plug
- 4 wires to thermocouple
- 6 cold box
- 7 copper plate (5.16.1.5)
- a Steel ball filling (not shown here).

Figure 20 — Cold insulation test apparatus

5.16.3 Test method

5.16.3.1 Preparation of the test piece

Use the complete item of footwear as the test piece. Fix the temperature probe to the insole or insock, if present, in order to measure the temperature in the forepart of the footwear directly above the area where the outsole contacts the support platen. Place the steel balls inside the footwear.

If the upper is not high enough to support the balls, increase its height with a collar of closed-cell elastomeric foam (EVA, PE, PU, etc.) of minimum substance 8 mm, which needs to be cut out carefully in order to avoid any gap of more than 3 mm in width. This auxiliary material may be fixed or stuck to the inner side of the collar, taking care that overlapping is limited to max. 20 mm at the lowest point of the upper edge of the collar.

The upper top opening is then carefully closed with a suitable plug, made up from semi-rigid polymer foam (for example polystyrene) of not less than 25 mm thickness, which may be composed by more than one layers. The plug is fixed to the collar or its prolongation by adhesive tape or other suitable means.

5.16.3.2 Test procedure

Adjust the temperature of the cold box to (-17 ± 2) °C and maintain this temperature during the test. Place the test piece on the support platen inside the cold box. Use the temperature measuring device connected to the temperature probe to measure the temperature on the insole/insock right after placing the test piece in the cold box and after (30 ± 1) min.

Rounded to the nearest 0,5 °C, note the temperature decrease measured after the (30 ± 1) min. period of cooling.

5.16.4 Test report

The following results shall be reported:

- see [4.4](#);
- for each tested size, the temperature decrease measured after the 30 min. period of cooling;
- the measurement uncertainty (when requested by the customer).

5.17 Determination of energy absorption of the seat region

5.17.1 Test equipment

5.17.1.1 Test equipment, capable of measuring compressive force up to 6 000 N (according to ISO 7500-1:2018, at least class 2), with a means of recording loading/deformation characteristics.

5.17.1.2 Test punch, the back part of a standardized last made in polyethylene¹⁾. The last shall be sectioned on a plane vertical to the feather edge and at 90° to the axis of the back part (see [Figure 21](#)). The dimension of the punch in relation to footwear shall be in accordance with [Table 9](#).

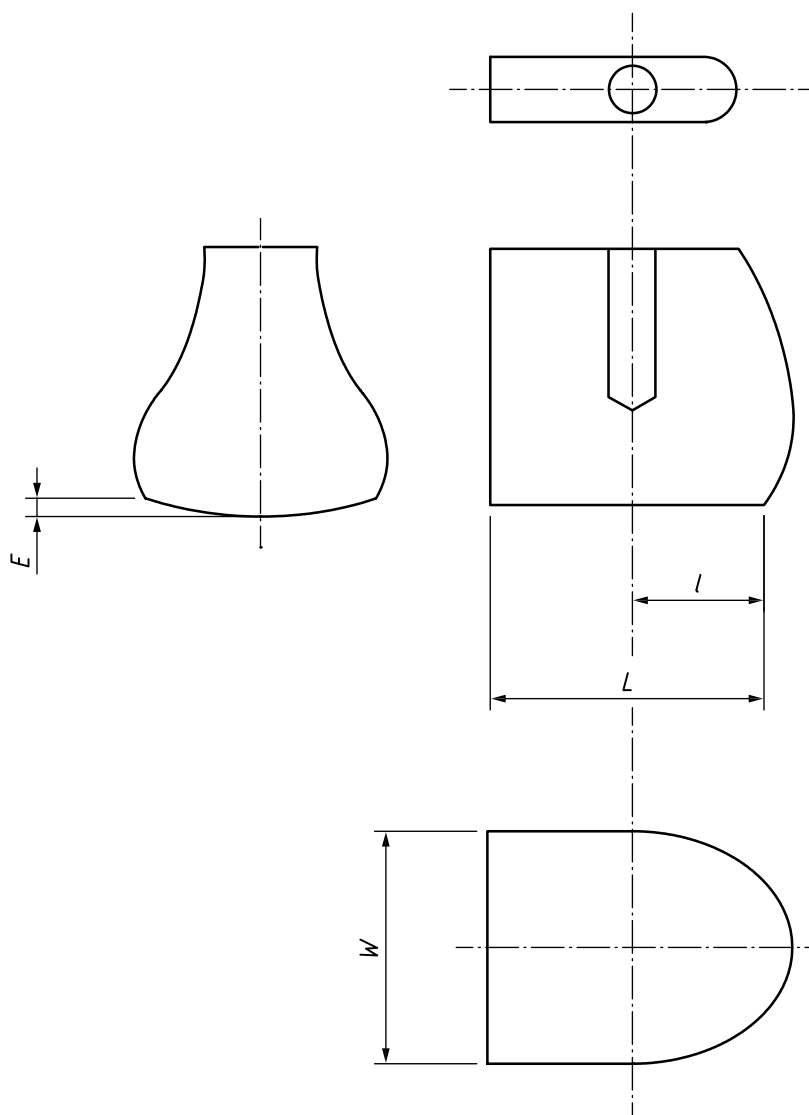

Figure 21 — Test punch for energy absorption test

Table 9 — Dimensions of the test punch depending on sizes

Sizes European (see Annex B)	Dimensions			
	$L \pm 2$ mm	$l \pm 2$ mm	$W \pm 2$ mm	$E \pm 1$ mm
up to 36	65 mm	32,5 mm	52,25 mm	2 mm
37 and 38	67,5 mm	33,7 mm	57 mm	2 mm
39 and 40	70,5 mm	35 mm	58,75 mm	2 mm
41 and 42	72,5 mm	36,2 mm	60,5 mm	3 mm

1) Suitable punches may be obtained from CTC, Lyon, France, <http://www.ctc.fr>. This information is given for the convenience of users of this document and does not constitute an endorsement by ISO of this product. Equivalent products may be used if they can be shown to lead to the same results.

Table 9 (continued)

Sizes European (see Annex B)	Dimensions			
	$L \pm 2$ mm	$l \pm 2$ mm	$W \pm 2$ mm	$E \pm 1$ mm
43 and 44	75,5 mm	37,7 mm	62,25 mm	3 mm
45 and above	77,5 mm	38,5 mm	64 mm	3 mm

5.17.2 Sampling and conditioning

For applicable conditioning, see [4.2](#).

For sampling, see [Table 1](#).

5.17.3 Test method

Place the test piece with the heel on a steel base and press the test punch against the bottom unit from the inside at the centre of the heel area at a test rate of (10 ± 3) mm/min until a force of $(5\ 000 \pm 50)$ N is obtained.

Plot the load/compression curve for each test and determine the energy absorption, E , in joules, rounded to the nearest 1 J, using [Formula \(2\)](#):

$$E = \int_{50\text{N}}^{5\ 000\text{N}} F ds \quad (2)$$

where

F is the applied compressive force, in N;

s is the distance, in mm.

5.17.4 Test report

The following results shall be reported:

- see [4.4](#);
- for each tested size, left and right, the energy absorption, E ;
- the measurement uncertainty (when requested by the customer).

5.18 Determination of resistance to water for whole footwear: trough test

5.18.1 Principle

A pair of footwear is worn while a defined number of paces is walked over a surface flooded with water to a defined depth. The extent of water penetration is determined by examination.

5.18.2 Test equipment

Horizontal watertight trough, having the following essential features (see also [Figure 22](#)):

- a) a moveable platform near each end, high enough and large enough to enable the tester to step up and turn around above the water level;
- b) sufficient length to allow the tester to take 10 normal paces in the water between the platforms;

- c) a width of approximately 0,6 m;
- d) a plug to enable the water to be drained away.

NOTE It is preferable for the trough to have a piped water supply so that it can readily be filled to the required depth.

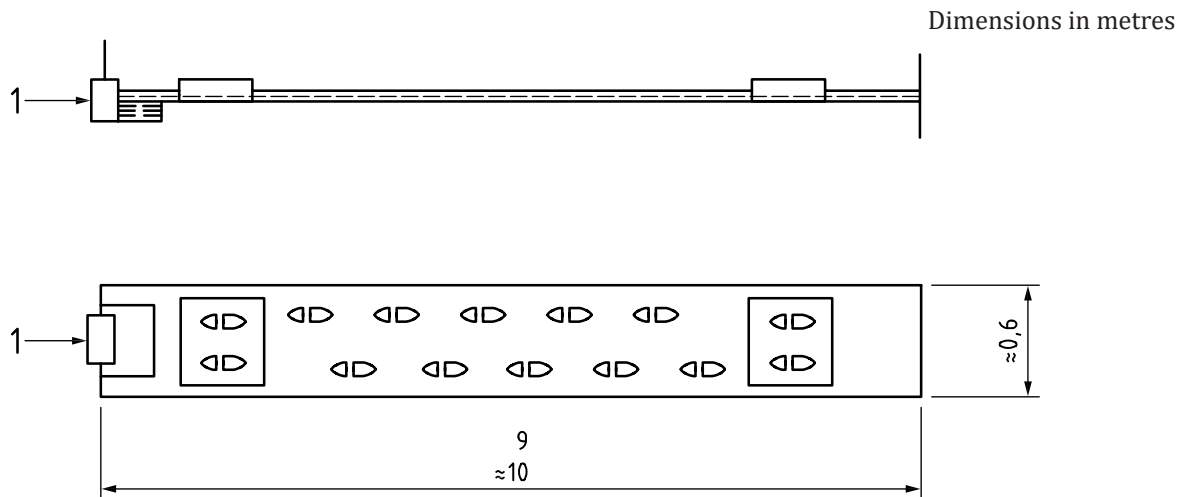

Key
1 plug

Figure 22 — Trough

5.18.3 Sampling and conditioning

Preconditioning of the footwear is not required.

For sampling, see [Table 1](#).

5.18.4 Test method

5.18.4.1 Testers

Choose the tester(s) so that the footwear fits the tester.

5.18.4.2 Test procedure

With the empty trough, position the turning platforms so that the tester takes 11 paces walking from one to the other with a normal length stride (i.e. so that each foot is placed on the floor of the trough five times). Fill the trough up to a depth of (30 ± 3) mm with water.

Ensure that the footwear is thoroughly dry. Put on the dry footwear over normal hose using a legging or guard to cover the top line, and step on to one of the platforms. Walk 100 trough lengths in the water using the platforms whenever turning. Take great care to make sure that no water is splashed over the top line of the footwear. To avoid splashing, walk at a slower pace than normal, if necessary, but preferably not slower than one pace per second.

After 100 trough lengths, step out of the trough, remove the footwear carefully, and examine the inside both visually and by touch for signs of water penetration. If no obvious water penetration has occurred, use absorbent paper ([5.19.2.4](#)) or other suitable means to determine if water penetration has occurred.

5.18.5 Test report

The following results shall be reported:

- see [4.4](#);
- for each tested size, left and right, any water penetration;
- the measurement uncertainty (when requested by the customer).

5.19 Determination of resistance to water for whole footwear: dynamic test

5.19.1 Principle

This test method is intended to provide a means of evaluating the degree of water resistance of footwear. The method is applicable to all types of shoes and boots.

The footwear is secured in a flexing machine with water at a defined level above the feather line. The footwear is flexed at a constant rate and inspected at intervals for water penetration.

5.19.2 Test equipment

5.19.2.1 Dynamic footwear flexing machine, having at each testing station:

- a system for flexing the footwear through an angle of $(22 \pm 5)^\circ$ at a rate of (60 ± 6) flexes per min;
- a flexible foot-form which is fitted inside the footwear to control the way the footwear flexes (this foot-form may be provided with water sensors);
- a clamping mechanism capable of holding the heel of the footwear firmly while the shoe is being flexed.

A screening test using the test method described in [8.5](#) can be used. Footwear bending less than 22° from the horizontal is not subjected to the test in [5.19.4](#).

5.19.2.2 Water-holding tank large enough to contain the footwear and flexing mechanism.

5.19.2.3 Means of recording the number of flexes carried out.

5.19.2.4 Absorbent paper.

5.19.3 Sampling and conditioning

Preconditioning of the footwear is not required.

For sampling, see [Table 1](#).

5.19.4 Test method

5.19.4.1 Preparation of test pieces

Use a pair of shoes as the test piece(s). It is preferred, although not necessary, to carry out the test in a standard controlled environment of $(23 \pm 2)^\circ\text{C}$ and $(50 \pm 5)\% \text{RH}$.

5.19.4.2 Test procedure

5.19.4.2.1 The footwear should be mounted on the flexing machine so that the flexing point corresponds to the ball joint position of a wearer's foot. Determine the flexing point by drawing a line

down the length of the insole of the test piece from the centre of the heel towards the centre of the toecap.

The flexible foot-form is covered by the absorbent paper (5.19.2.4) before mounting the footwear sample on the flexible foot-form. Then protect the absorbent paper by a thin stocking. This will help at the end of the test for the water detection. Any other means of detection (for example, electrical detector) is acceptable.

5.19.4.2.2 Measure along the line the appropriate distance from the heel in Table 10 to the nearest millimetre and mark this point. This corresponds to the typical position of the ball joint of the wearer's foot.

5.19.4.2.3 Draw a line across the width of the insole passing through this marked point and at 90° to the line drawn as described in 5.19.4.2.2. This is regarded as the flexing line of the footwear.

Table 10 — Average distance from the heel end of the insole to the ball joint position of the foot

Sizes European (see Annex B)	Heel/ball length on insole ±2 mm
33	145
34	149
35	154
36	159
37	163
38	168
39	173
40	177
41	182
42	187
43	191
44	196
45	201
46	205
47	210
48	215
49	219
50	224

5.19.4.2.4 Secure the test piece onto the flexing system so that the flexing point is as close as possible to the line drawn as described in 5.19.4.2.3.

5.19.4.2.5 Ensure that all the fastenings (e.g. laces, straps, zips and touch-&-close fasteners) are engaged, suitably adjusted, tightened and fully secure and that the ends of the laces, if present, will not hang in the water during testing.

5.19.4.2.6 If there is any opening at the top of the footwear which would allow water to splash inside, seal this with a polythene bag or sheet.

5.19.4.2.7 Add water into the tank

- For class I footwear, up to a height of 20 mm above the lowest point of the feather line of the footwear.
- For hybrid footwear, up to height higher or equal to H (as defined in ISO 20345:2021, Figure 6 and Table 8).

5.19.4.2.8 Operate the machine so that the footwear is flexed at a rate of (60 ± 6) flexes per min, for a duration of (80 ± 5) min.

5.19.4.2.9 Remove carefully the test piece from the machine, take off the flexible foot-form and the stocking and inspect the absorbent paper to detect any water penetration.

NOTE Water penetration can also be detected by sensors.

5.19.5 Test report

The following results shall be reported:

- see [4.4](#);
- for each tested size, left and right, any water penetration;
- the measurement uncertainty (when requested by the customer).

5.20 Determination of impact resistance of a metatarsal protection

5.20.1 Test equipment

5.20.1.1 Impact apparatus, as described in ISO 22568-1:2019, 5.3.1.1.

5.20.1.2 Clamping device, consisting of a smooth steel plate at least 19 mm thick of a minimum hardness 60 HRC, with a device for clamping the heel and joint region of the shoe (see [Figure 23](#)).

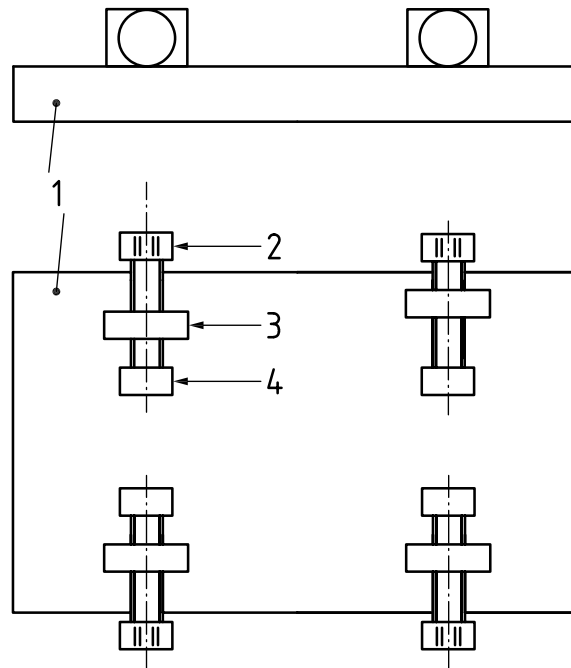

Key

- 1 base plate
- 2 screw
- 3 threaded lug
- 4 clamping plate

Figure 23 — Metatarsal protection clamping device

5.20.1.3 Dial gauge, see [5.4.1.4](#)

5.20.1.4 Wax test form

5.20.1.4.1 This represents the inside of the footwear and is used to measure the deformation of the metatarsal region during impact. This form shall be made by one of the methods described in [5.20.1.4.2](#) and [5.20.1.4.3](#).

5.20.1.4.2 Production of the wax test form using the making last (preferred method) involves a two stages operation, the first of which is to form a mould of the last used to make the footwear. The second consists of producing a wax test form of this mould.

Stage 1: Using a last one size smaller than the test footwear, fill in any 'V' cut in the last and any holes and form a shell using a vacuum former and a thermoplastic material (e.g. 0,4 mm thick un-plasticized PVC sheets) over the upper surface. When cool, trim off surplus material below the feather edge of the last and remove. Similarly, form a shell over the bottom surface and trim at between 5 mm and 10 mm above the feather edge to form a flange on the edge. Join the two shells, using a tape, such that the upper shell fits inside the flange formed on the bottom shell and tape the join. Cut the joined shell to produce front and heel end moulds (see [Figure 24](#)).

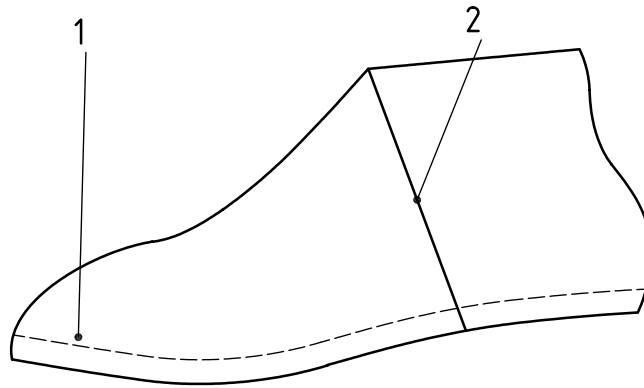

Key

- 1 flange overlapping top shell
- 2 cut

Figure 24 — Shells joined together showing separation cut

Stage 2: Stand up the two moulds in a container such that the top surfaces are horizontal, and support with sand (see [Figure 25](#)). Prepare the wax for the test last from a mixture of paraffin wax (with a melting point of 50 °C to 53 °C) and beeswax in a ratio 5:1. Combine the paraffin wax and the beeswax in a suitable mixing vessel, place in an oven and heat to approximately 85 °C. Remove the vessel from the oven and stir until the mixture cools to approximately 60 °C and pour into the two moulds. Insert a loop of thin tape into the molten wax to facilitate later removal from the test footwear, ensuring that the tape does not penetrate to the outer surface of the front mould (see [Figure 25](#)). Allow to cool. While cooling the wax form may shrink. If necessary, re-shape the moulds and top up as required and allow to fully cool. Remove the wax forms from the moulds.

NOTE With care, the moulds can be used to produce a number of wax forms.

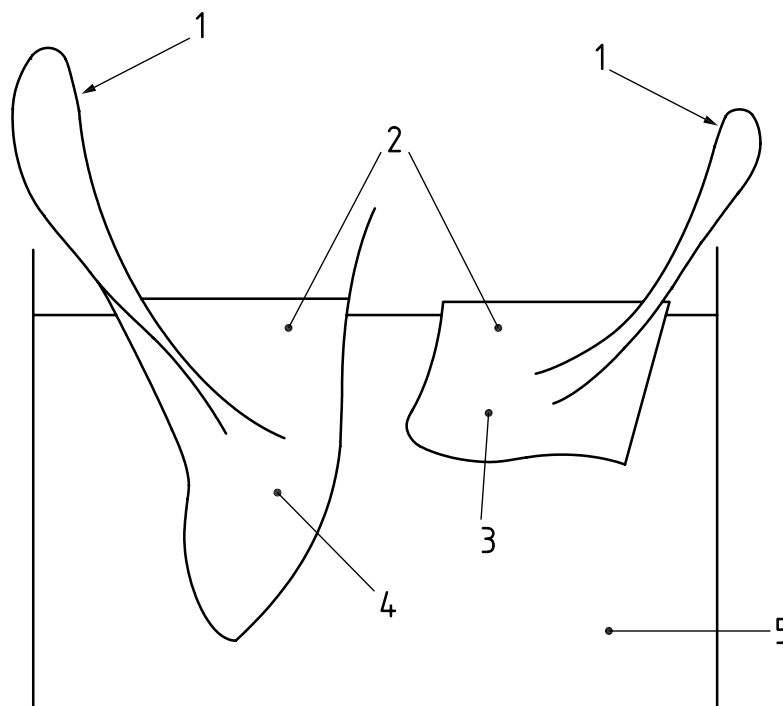

Key

- 1 tape to help in removal from test piece
- 2 moulds filled to top with wax
- 3 heel end mould
- 4 toe end mould
- 5 container filled with sand

Figure 25 — Moulds supported in sand and filled with wax

5.20.1.4.3 Production of wax forms using footwear involves a 2 stages operation, the first of which is to produce a plaster of Paris cast of the inside of the footwear, followed by the production of moulds and casts as described in [5.20.1.4.1](#). It requires one extra item of footwear, which will be destroyed during the production of the plaster of Paris mould.

Stage 1: Coat with petroleum jelly or releasing agent the inside of an item of footwear the same size as that to be tested. Secure the fastening system and fill to the top of the opening with a mixture of plaster of Paris and water. Leave until set and then remove by cutting away the footwear. After removal, place in an oven at about 80 °C to dry.

Stage 2: Continue as for stage 1 in [5.20.1.4.1](#) using the plaster of Paris cast in the place of making last.

Continue as for stage 2 in [5.20.1.4.1](#).

5.20.2 Sampling and conditioning

Preconditioning of the footwear is not required.

For sampling, see [Table 1](#).

5.20.3 Test method

5.20.3.1 Test procedure

Use the complete item of footwear as the test piece. If removable insoles are present, remove these before the test.

Insert the wax forms into the test piece and close the fastening system. The test axis as defined in [5.4.3.1](#) should be marked onto the footwear. Clamp the test piece onto the base plate ([5.20.1.2](#)) using the clamping device ([5.20.1.2](#)) and position it such that, at the moment of impact, the striker shall be at 90° to the axis of the test piece, as described in [5.4.3.1](#). The striker shall hit the test piece once, at a distance from the toe as specified in [Table 11](#) (see [Figure 26](#)).

Table 11 — Distances of impact

Size of footwear European	Distance of impact from toe ^a ±2 mm
36 and below	90
37 and 38	95
39 and 40	100
41 and 42	105
43 and 44	110
45 and above	115

^a This distance is measured along the test axis from the toe end.
 If necessary due to the shape of the footwear, the impact distance can be adapted of ±10 mm to make sure that the striker is hitting the metatarsal protection.

Place a wedge under the forepart of the test piece to prevent deformation of the footwear during impact.

Allow the striker to drop onto the test piece from an appropriate height (measured vertically from the impact point) to give an impact energy of (100 ± 2) J.

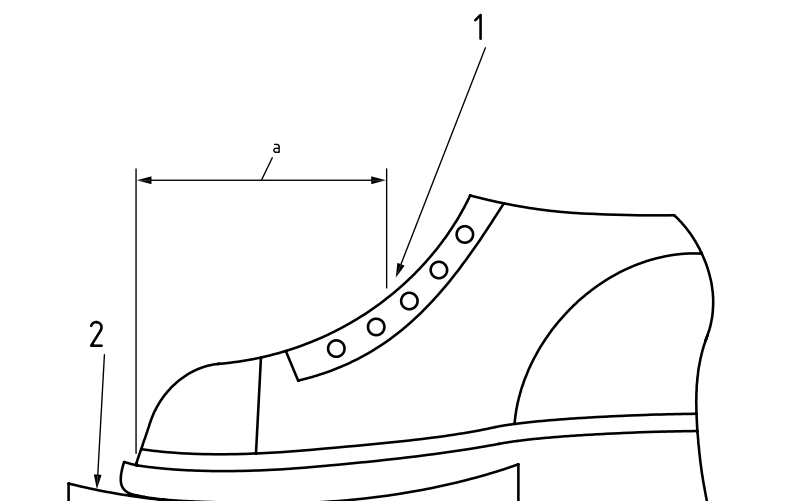

Key

- 1 point of impact
- 2 wedge
- ^a Distance from [Table 11](#).

Figure 26 — Point of impact

5.20.3.2 Test results

Note the position of the metatarsal protection after the test.

After testing, carefully remove the wax form from the footwear and position it on a flat support such that it maintains the same horizontal orientation it had within the test piece.

Using the dial gauge (5.20.1.3), measure the vertical height, H_v , above the flat surface on the axis as determined in 5.4.3.1 at the point of maximum deformation.

Measure the thickness of the removable insock, e_{ri} , in the region of the strike using the dial gauge (5.20.1.3).

Determine the clearance value, C_v as, $C_v = H_v - e_{ri}$

5.20.3.3 Construction checking

Measure the overlapping of the metatarsal device above the top of the toe cap, O_d , in millimetre.

Check whether or not that the metatarsal device cannot be removed from the footwear without damaging it.

5.20.4 Test report

The following results shall be reported:

- see 4.4;
- for each tested size, left and right:
 - the clearance value C_v ;
 - the overlapping, O_d ;
 - the permanent attachment of the device to the footwear;
 - the position of the metatarsal protection after testing;
 - the measurement uncertainty (when requested by the customer).

5.21 Determination of the dimension of the ankle protection

5.21.1 Sampling and conditioning

For applicable conditioning, see 4.2.

For sampling, see Table 1.

5.21.2 Test method

5.21.2.1 Preparation of the test piece

Use one complete item of footwear as the test piece.

5.21.2.2 Measurement

For each footwear size, using the dimension given in Table 12, position the point A on the footwear upper (see Figure 27). Then using the point, A as the centre, draw the circle (see Figure 27), using the diameter given in ISO 20345:2021, Table 18

Determine that the ankle protection covers fully the drawn circle.

Table 12 — Dimensions for the assessment of the ankle protection

Dimensions in millimetres

Footwear size European	Internal ankle position of point A		External ankle position of point A	
	<i>H</i>	<i>L</i>	<i>H</i>	<i>L</i>
40 and lower	75 ± 10	65 ± 10	67 ± 10	50 ± 10
41 to 43	85 ± 10	75 ± 10	75 ± 10	55 ± 10
44 and more	90 ± 10	85 ± 10	80 ± 10	62 ± 10

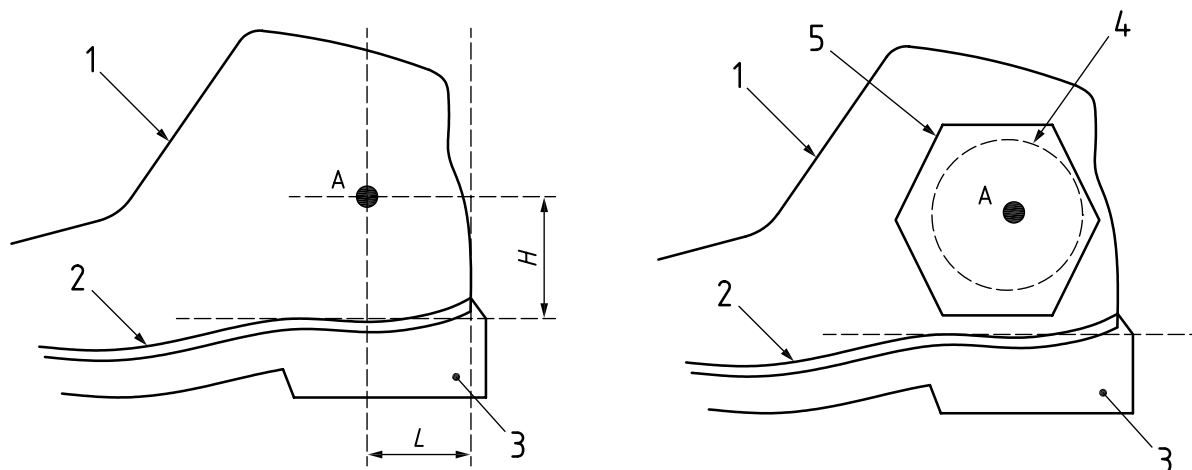

Key

- 1 upper
- 2 insoles/insole
- 3 outsole
- 4 minimum diameter of the ankle protection area
- 5 ankle protection area
- L* measured distance from the heel arch to the edge of the outsole
- H* measured height of the ankle from the heel arch

Figure 27 — Determination of the dimensions of the ankle protection

5.21.3 Test report

The following results shall be reported:

- see 4.4;
- if the ankle protection fully covers the minimum protection area (yes/no);
- the measurement uncertainty (when requested by the customer).

5.22 Determination of the shock absorption capacity of ankle protection materials incorporated into the upper

5.22.1 Principle

A test piece taken from the ankle protective area of the upper is subjected to an impact test and the transmitted force measured.

5.22.2 Test equipment

5.22.2.1 Impact apparatus, consisting of a guided mass of $(5\,000 \pm 10)$ g which strikes a test anvil in a vertical drop. The centre of gravity of the falling weight shall be vertically above the centre of the anvil during the whole operation. The drop height shall be approximately 0,2 m, in order to ensure a kinetic energy of $(10 \pm 0,2)$ J. See [5.4.3.3](#).

5.22.2.2 Striker. The drop striker face shall be made from polished steel with dimensions of $80\text{ mm} \times 40\text{ mm}$, all edges being rounded with a radius of (5 ± 1) mm.

5.22.2.3 Anvil, made of polished steel with an overall height of (175 ± 25) mm, consisting of a cylinder with the radius $(25 \pm 0,5)$ mm which in its upper part is rounded to a hemispherical shape also with $(25 \pm 0,5)$ mm radius (see [Figure 28](#)). The anvil shall be attached, in a vertical position and through a piezo-electric load cell or gauge cell, to a solid mass of at least 600 kg. The cell shall be properly preloaded and calibrated.

Dimensions in millimetres

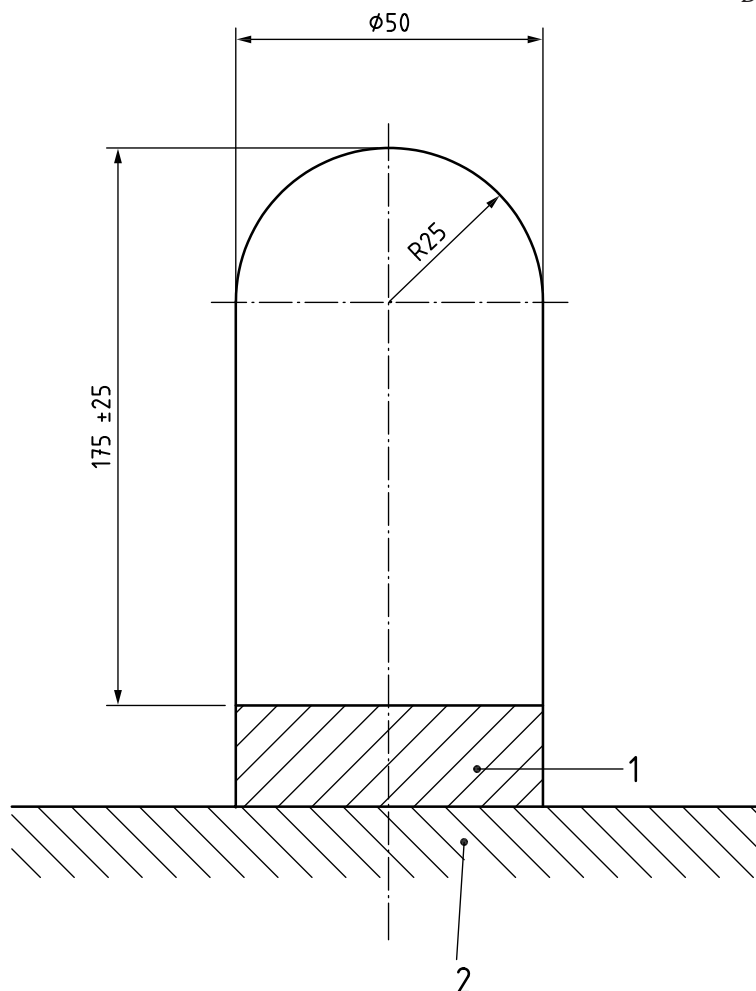

Key

- 1 force transducer
- 2 solid base

Figure 28 — Anvil and base

5.22.2.4 Force measurement instrumentation. The anvil shall be mounted so that during impact testing the whole force between the anvil and the massive base of the apparatus passes through a high speed force transducer (for instance piezoelectric quartz instruments) in line with its sensitive axis. The force transducer shall have frequency response of at least 7 kHz, a calibrated range of not less than 70 kN and a lower threshold of less than 1 kN. The output of the force transducer shall be processed by a charge amplifier and displayed and recorded on suitable instruments. The measuring system including the drop assembly shall have a frequency response in accordance with channel frequency class (CFC) 1 000 of ISO 6487:2015.

5.22.2.5 Templates, prepared from a suitable flexible material (e.g. fabric, fleece, paper), capable of maintaining its shape and dimensions during use.

The templates shall be circular and of the dimensions stated in ISO 20345:2021, Table 18. Their centre point shall be indicated by suitable marking or by cutting a small hole.

5.22.3 Sampling and conditioning

For applicable conditioning, see [4.2](#).

For sampling, see [Table 1](#).

Two samples (inside and outside) shall be taken from each of three items of footwear (small, medium and large sizes) to enable impact tests to be performed, three on outer ankle protection (mandatory) and three on inner ankle protection (if applicable, since optional).

5.22.4 Test method

5.22.4.1 Preparation of the test pieces

The footwear is marked in accordance with [5.21](#) to identify the ankle point and the zone of protection.

5.22.4.2 Test procedure

The strike point shall be not less than 10mm from the edge of the zone of protection marked on the specimen.

The test piece is positioned outer surface upwards on the anvil in such a way that a part of the test area covers the centre point of the anvil. The test piece may be fixed in the selected position by covering with a suitably thin net or fabric with a centre hole of 20 mm to 25 mm diameter to avoid influencing the result. This auxiliary device should be pulled down, by means of elastic straps, with an overall force of 5 N to 10 N, which can easily be controlled by the force measuring system itself.

The drop striker is then released. The transmitted force, as well as damage or breakage of the test piece, is recorded.

The test piece shall be tested once only at each point.

The test result is the average of the 3 (only outer side protection) or 6 (outer and inner side protection) transmitted forces and the highest single value.

5.22.5 Test report

The following results shall be reported:

- see [4.4](#);
- the mean value of transmitted force;
- the highest obtained single value;

- the measurement uncertainty (when requested by the customer).

5.23 Determination of cutting resistance

5.23.1 Sampling and conditioning

For applicable conditioning, see [4.2](#).

For sampling, see [Table 1](#).

5.23.2 Dimension of the cut resistant protective area

As described in [Figure 29](#):

- Measure “a” the overlap over the toe cap ([Figure 29 a](#)) and the protective area. If the footwear has no toecap ([Figure 29 b](#)), the protection against cut shall be checked in the toe area. The front part of the footwear shall be tested.
- Measure the minimum height “b” of the protective area, from the top of this protection to the feather line of the footwear

Assess if there is any gap between the protective area and the feather line.

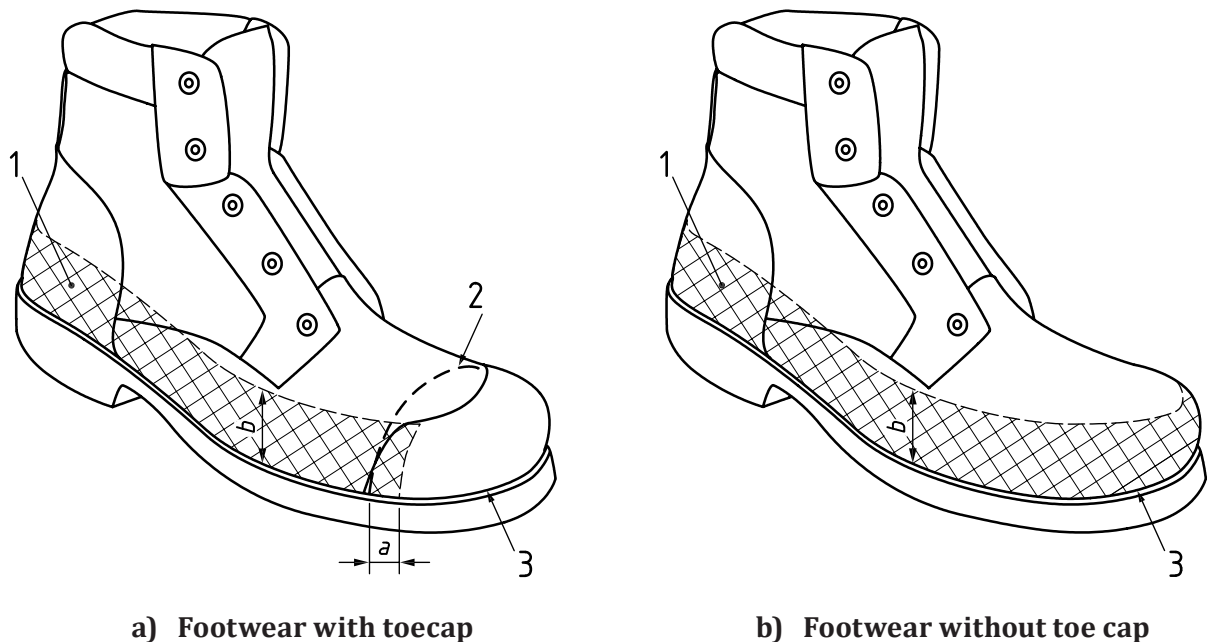

Key

- 1 area to be tested an overlap over the toe cap
- 2 rear edge of the toe cap
- 3 feather line
- a Overlap toe cap / protective area in mm.
- b Height of the protected area in mm.

Figure 29 — Sampling area for cutting resistance

5.23.3 Test method

5.23.3.1 Preparation of the test piece

Samples shall be taken from the upper material assembly.

Take samples allowing to perform 2 tests (see [Table 1](#)). The length of the test pieces are (100 ± 10) mm and the width as large as possible (including the protective area).

5.23.3.2 Test procedure

Perform the test in accordance with the method described in ISO 23388:2018, 6.2.

The result is the average of the 2 index results.

5.23.4 Test report

The following results shall be reported:

- see [4.4](#);
- *a*, overlap over the toe cap;
- any gap between the protection area and the feather edge;
- *b*, height of the protected area;
- the mean value of the index;
- if the footwear material dulls the blade, the reported result is: “blade dulling”, see ISO 23388:2018, 6.2.6;
- the measurement uncertainty (when requested by the customer).

5.24 Scuff caps

5.24.1 Sampling and conditioning

For applicable conditioning, see [4.2](#).

For sampling, see [Table 1](#).

5.24.2 Test method for the abrasion resistance of the scuff caps

Take a circular sample of the scuff cap of diameter $(38 \pm 0,5)$ mm in the area of the toe cap (see [Figure 29](#)).

Perform the test in accordance with the method described in ISO 23388:2018, 6.1.

5.24.3 Test report

The following results shall be reported:

- see [4.4](#);
- the thickness of the scuff cap;
- the cycles number necessary to develop a hole in the scuff cap;
- the measurement uncertainty (when requested by the customer).

5.25 Determination of seam strength

5.25.1 Sampling and conditioning

For applicable conditioning, see [4.2](#).

For sampling, see [Table 1](#).

5.25.2 Test method

Perform the test in accordance with the method described in ISO 17697:2016, method B.

5.25.3 Test report

The following results shall be reported:

- see [4.4](#);
- the minimum seam strength in N/mm;
- the measurement uncertainty (when requested by the customer).

6 Test methods for upper, lining and tongue

6.1 Determination of thickness of upper

6.1.1 Sampling and conditioning

For applicable conditioning, see [4.2](#).

For sampling, see [Table 1](#).

6.1.2 Test method

Determine the thickness in accordance with Method A in ISO 23529:2016, 7.1, using a thickness gauge with a flat presser foot of $(10 \pm 0,1)$ mm diameter and a pressure of (10 ± 2) kPa. The thickness of the upper shall include any associated textile layer.

6.1.3 Test report

The following results shall be reported:

- see [4.4](#);
- the thickness of the upper;
- the measurement uncertainty (when requested by the customer).

6.2 Measurement of the height of the upper

6.2.1 Sampling and conditioning

Preconditioning of the test pieces is not required.

For sampling, see [Table 1](#).

6.2.2 Test method for the complete upper

6.2.2.1 Preparation of the test piece

Use one complete item of footwear as the test piece.

6.2.2.2 Measurement

The height (in mm) of the upper is the vertical distance between the lowest point on the insole/insock, i.e. between the heel breast and the back of the heel (see [Figure 30](#)) and the highest point on the upper. The tongue is not taken into account for this measurement.

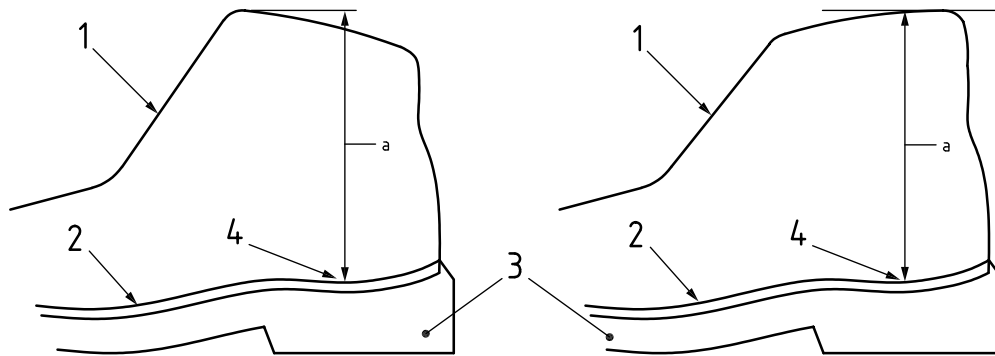

Key

- 1 upper
- 2 insole/insocks
- 3 outsole
- 4 lowest point of the insole/insock within the heel region
- a Height of the upper.

Figure 30 — Measurement of the height of the upper

6.2.2.3 Test report

The following results shall be reported:

- see [4.4](#);
- the height of the upper;
- the measurement uncertainty (when requested by the customer).

6.2.3 Test method for the determination of the area for non-water vapour permeable materials

6.2.3.1 Preparation of the test piece

Use one complete item of footwear as the test piece.

6.2.3.2 Measurement

If footwear has a design A the full upper is tested. For other designs, the upper part over a line drawn at a height H_1 (given in ISO 20345:2021 Table 4, design A) shall be removed, see [Figure 31](#).

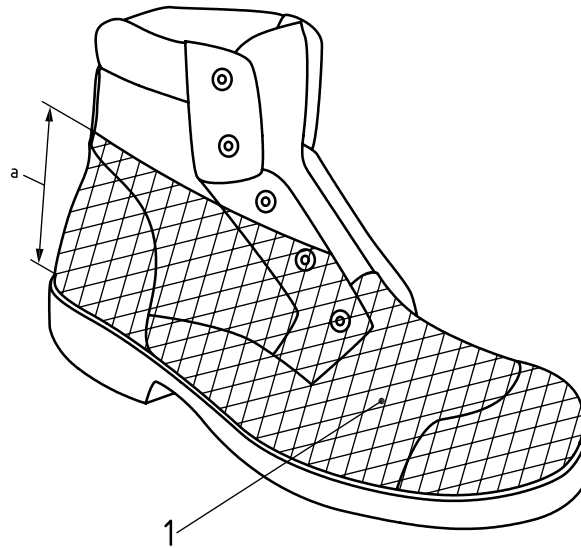

Key

- 1 upper part that shall be kept for the measurement of the area for non-water vapour permeable materials
- ^a H_1 height of the upper given in ISO 20345:2021, Table 4, design A.

Figure 31 — Preparation of the area for non-water vapour permeable materials

Dismantle the footwear in order to be able to put the upper flat and exclude the area corresponding to

- upper material above the drawn line H_1 ,
- the toecap,
- the lacing system (eyelet support, hook attachment),
- collar,
- stiffener/counter,
- contact with the upper/sole bounding.

The full area, S_T , is identified. Determine the total surface, S_T , see [Figure 32](#).

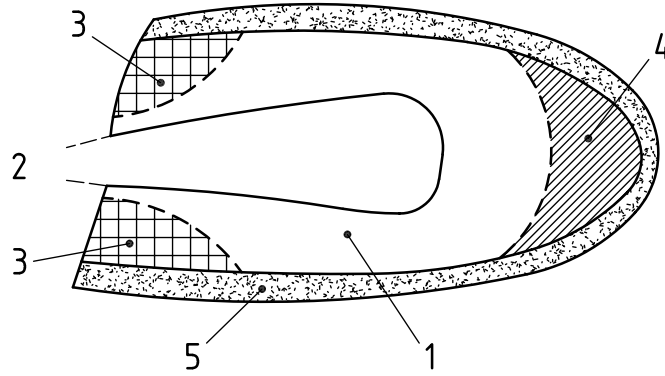

Key

- 1 area S_T
- 2 cutting line corresponding the height H_1
- 3 the upper area over the stiffener/counter
- 4 the upper area over the toe cap
- 5 the upper area in contact with the upper/sole bounding

Figure 32 — Determination of the area S_T for non-water vapour permeable materials

Identify all the different materials used in the S_T area and determine the surfaces, S_i , of those that are not water vapour permeable. Calculate for each material the percentage, P_i , with the following [Formula \(3\)](#):

$$P_i = \frac{S_i \times 100}{S_T} \quad (3)$$

6.2.3.3 Test report

The following results shall be reported:

- see [4.4](#);
- the percentage P_i of each non water vapour permeable material present in the area, S_T ;
- the measurement uncertainty (when requested by the customer).

6.3 Determination of tear strength of the upper, lining and/or tongue

6.3.1 Sampling and conditioning

For applicable conditioning, see [4.2](#).

For sampling, see [Table 1](#).

For coated fabric and textile (knitted, woven and non-woven materials), use a test piece as large as possible. The width shall be between 25 mm and 50 mm and the length between 50 mm and 200 mm, with a cut 20 mm long placed centrally and parallel with the longer sides to form a trouser shaped test piece.

6.3.2 Test method

The tests shall be carried out in a standard atmosphere of $(23 \pm 2) ^\circ\text{C}$ and $(50 \pm 5) \% \text{RH}$.

Determine the tear strength in accordance with one of the following methods (whichever is appropriate):

- ISO 3377-2:2016 for leather;
Sampling:
2 test pieces in the same direction and one test piece perpendicular
Expression of results
The result is the average of the 3 measurements
- ISO 4674-1:2016, method B, for coated fabric and textile.

Sampling :
2 test pieces in the same direction and one test piece perpendicular
Testing:
When it is not possible to obtain a test piece with the dimensions required in ISO 4674-1:2016 method B, it shall be torn completely
Expression of results:
The result is the average of the 3 measurements

6.3.3 Test report

The following results shall be reported:

- see [4.4](#);
- the tear resistance of the upper (according to the relevant standard);
- the measurement uncertainty (when requested by the customer).

6.4 Determination of the tensile properties of the upper material

6.4.1 Sampling and conditioning

For applicable conditioning, see [4.2](#).

For sampling, see [Table 1](#).

6.4.2 Test method

6.4.2.1 General

The tests shall be carried out in a standard atmosphere of $(23 \pm 2) ^\circ\text{C}$ and $(50 \pm 5) \% \text{RH}$

Determine the tensile properties of the upper material in accordance with the appropriate method given in [Table 13](#).

Table 13 — Test methods for tensile properties assessment

Type of material	Test method	Tensile property
Leather split	ISO 3376:2020	Tensile strength
Rubber ^a	See 6.4.2.2	Breaking force
Polymeric ^b	ISO 4643:1992	Modulus at 100 % elongation, elongation at break
^a The test pieces shall include any associated textile layer if present.		
^b Remove the textile layer before testing.		

6.4.2.2 Determination of the breaking force of a rubber boot upper

6.4.2.2.1 Apparatus

Tensile-testing machine (according to ISO 7500-1:2018, at least class 2), with a constant rate of traverse and with means for indicating or preferably recording the maximum load applied to the test piece at rupture. The central points of the two jaws of the machine shall be in the line of pull, the front edges shall be perpendicular to the line of pull and their clamping faces shall be in the same plane. The jaws shall be capable of holding the test piece without allowing it to slip, they shall be so designed that they do not cut or otherwise weaken the test piece and they shall be wider than the prepared test piece. The rate of traverse of the pulling jaw shall be (100 ± 10) mm/min.

6.4.2.2.2 Test pieces

Cut test pieces from the boot upper above the vamp so that they are (25 ± 1) mm wide and of a convenient length to allow a distance of 75 mm between the jaws of the tensile-testing machine.

Cut three test pieces (two in one direction and one across). Where the height of the product does not permit a test piece to be cut to give a free length of 75 mm between the jaws, use a free length of (25 ± 1) mm.

6.4.2.2.3 Procedure

Place each of the test pieces in the tensile-testing machine in turn and measure the force required to break each test piece.

6.4.2.2.4 Expression of results

Express the breaking force of the boot upper in both the length and breadth directions as the mean value, in newtons, of the breaking force recorded for each of the three test pieces. Record the dimensions of the test piece used.

6.4.3 Test report

The following results shall be reported:

- see [4.4](#);
- the tensile properties of the upper material (according to the relevant standard, see [Table 13](#));
- the measurement uncertainty (when requested by the customer).

6.5 Determination of upper flexing resistance

6.5.1 Sampling and conditioning

For applicable conditioning, see [4.2](#).

For sampling, see [Table 1](#).

6.5.2 Test method

6.5.2.1 General

Determine the upper flexing resistance in accordance with whichever of the following methods is appropriate:

- see [6.5.2.2](#) for rubber (the test piece should include any associated textile layer);

— ISO 4643:1992, Annex B, for polymers (test carried out at $(-5 \pm 2) ^\circ\text{C}$).

6.5.2.2 Determination of resistance to flexing of a rubber upper

6.5.2.2.1 Test equipment

6.5.2.2.1.1 Micrometre dial gauge, accurate to within 0,1 mm.

6.5.2.2.1.2 Flexing machine, the essential features of which shall be as follows.

The machine shall have an adjustable stationary part with grips 25 mm in width for holding one end of the test piece in a fixed position, and a similar reciprocating part for holding the other end of the test piece.

The reciprocating part shall be mounted so that its motion is in the direction of, and in the same plane as, the centreline between the grips, and its travel adjusted so that the reciprocating part approaches the stationary grip to a distance of (13 ± 1) mm and recedes to a distance of (57 ± 1) mm.

The cam which actuates the reciprocating part shall be driven by a constant-speed motor to give (340 ± 30) flexes, and with sufficient power to flex at least six and preferably twelve test pieces at one time.

The test pieces shall be arranged in two equal groups so that one group is being flexed while the other is being straightened, thus reducing the vibration in the machine. The grips shall hold the test pieces firmly and shall enable individual adjustments to be made to each test piece.

The test equipment shall be kept away from any ozone source.

6.5.2.2.2 Test procedure

6.5.2.2.2.1 Test pieces

Cut one test piece from the thinnest portion of the boot upper containing the fewest layers of fabric. The test piece shall have the dimensions shown in [Figure 33](#).

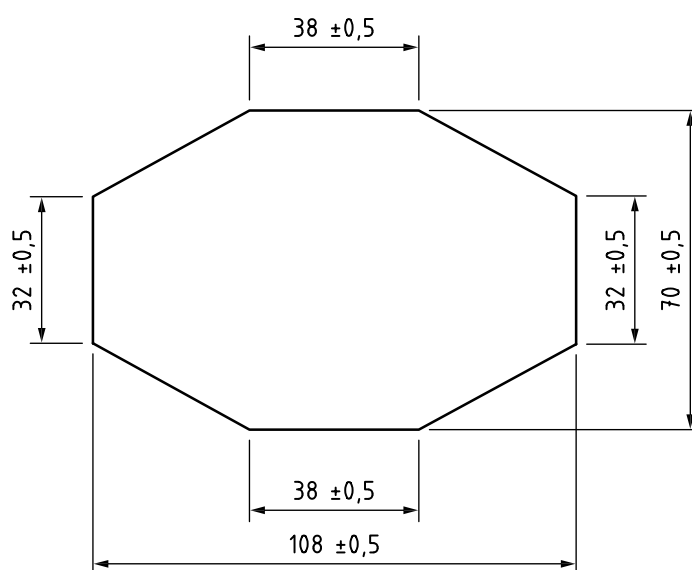

Figure 33 — Test piece for flexing test

Ensure that the test pieces are cut cleanly from the sample material.

Measure the thickness of the test pieces with a micrometre dial gauge at each corner and in the centre and take the median of the five readings as the thickness of the individual test piece to the nearest 0,1 mm.

6.5.2.2.2 Fitting the test pieces in place

Fold the test piece symmetrically about its major axis so that the rubber surface is outwards. In the folded condition, insert one tapered end into the stationary grip so that the central axis of the test piece is midway between the stationary and reciprocating grips when these are at their greatest separation. Both folded tapered ends shall be aligned with the edges of their respective grips. For convenience, the tapered ends of the test piece may be marked at the gripping points in order to align the test piece correctly in the grips. Tighten the grip, insert the other end of the test piece into the reciprocating grip and tighten.

It is essential that the test piece is not under tension.

[Figure 34](#) shows the arrangement of the apparatus and test piece during the flexing cycle.

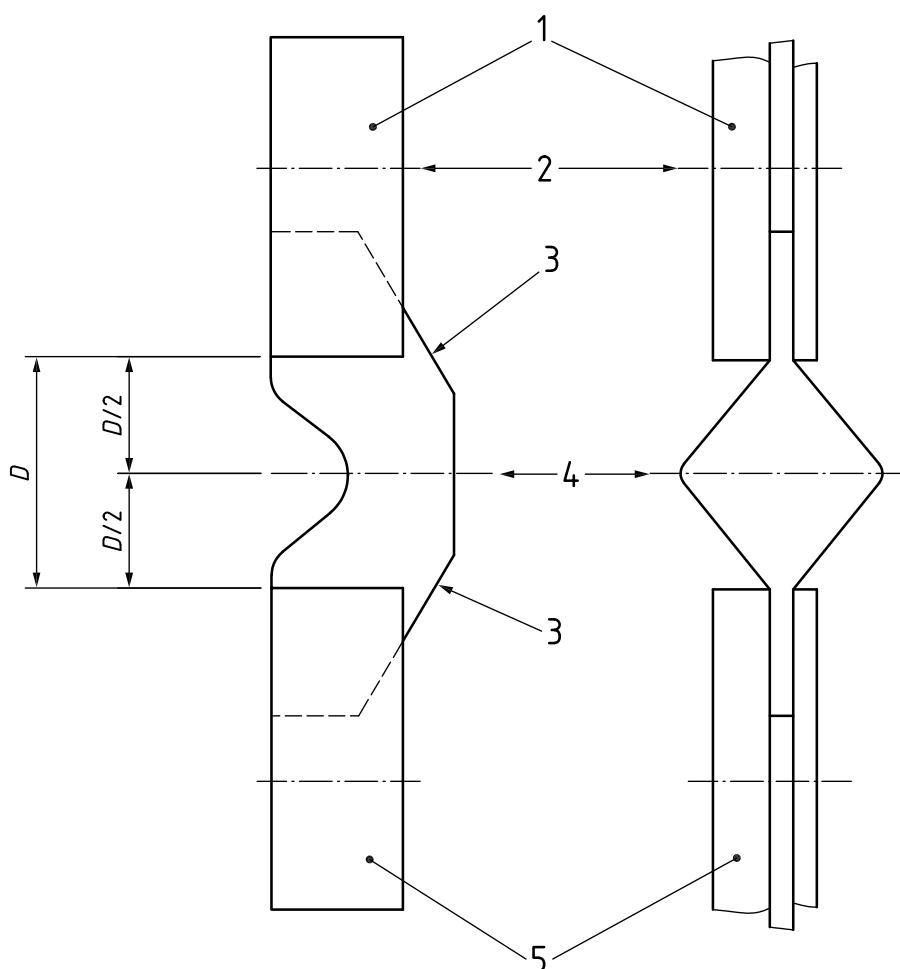

Key

- 1 stationary grip
- 2 centre of guide pins (approximately 6 mm diameter)
- 3 tapered ends of test piece
- 4 central axis of test piece
- 5 reciprocating grip

Figure 34 — Arrangement of apparatus and test piece during the flexing cycle

6.5.2.2.3 Test procedure

Carry out the required number of flex cycles. Record the number of completed flex cycles by using a trip counter operated by one of the reciprocating grips. A complete to-and-fro movement of the reciprocating grip shall be counted as one flex cycle. The ambient temperature during testing shall be $23\text{ °C} \pm 4\text{ °C}$.

Remove the test piece and examine for damage (for example pinholes, cracking...).

Record the number of flex cycles completed, the thickness of the test piece and whether any pinholes or cracks were visible with the unaided eye, for each test piece tested.

6.5.3 Test report

The following results shall be reported:

- see [4.4](#);
- upper flexing resistance (see [6.5.2.2](#));
- the measurement uncertainty (when requested by the customer).

6.6 Determination of water vapour permeability (WVP)

6.6.1 Principle

The upper is pre-treated with a flexing test method, after pre-treatment, the water vapour permeability of the upper is measured.

6.6.2 Sampling and conditioning

For applicable conditioning, see [4.2](#).

For sampling, see [Table 1](#) and the appropriate standard hereafter.

6.6.3 Pre-treatment test method

The test pieces (approximately 70 mm × 45 mm) are tested according to ISO 5402-1:2017, with 20 000 flexions (dry conditions).

6.6.4 WVP measurement

After pre-treatment, see [6.6.3](#), cut a circular test piece of 34 mm diameter from the pre-flexed sample centrally about the point at which the flexing creases meet.

The tests shall be carried out in a standard atmosphere of $(23 \pm 2)\text{ °C}$ and $(50 \pm 5)\%$ RH

The test pieces are tested according to ISO 14268:2012, with a pre-test of (60 ± 5) min (see ISO 14268:2012, 6.6) and a testing time of (450 ± 30) min (see ISO 14268:2012, 6.9).

The results shall be expressed as defined in ISO 14268:2012, Clause 7.

6.6.5 Test report

The following results shall be reported:

- see [4.4](#);
- WVP for each test pieces;
- the measurement uncertainty (when requested by the customer).

6.7 Determination of water vapour absorption (WVA)

6.7.1 Principle

An impermeable material and the test piece are clamped over the opening of a metal container, which holds 50 ml of water, for the duration of the test.

Water absorption of the test piece is determined by the difference in its mass before and after the test.

6.7.2 Test equipment

6.7.2.1 Circular metal container (volume 100 cm³) and an upper ring, between which the impermeable material and the test piece are clamped (see [Figure 35](#)). The container and the ring shall have an internal diameter of 3,5 cm which corresponds to a test area of approximately 10 cm². The upper ring shall be clamped to the apparatus with three hinged bolts equipped with wing nuts, or by any other appropriate means.

6.7.2.2 Balance, with an accuracy of 1mg.

6.7.2.3 Stopwatch, accuracy to 1s

6.7.3 Sampling and conditioning

For applicable conditioning, see [4.2](#).

For sampling, see [Table 1](#).

6.7.4 Test method

6.7.4.1 Preparation of test piece

Cut a test piece 4,3 cm in diameter.

6.7.4.2 Test procedure

The tests shall be carried out in a standard atmosphere of (23 ± 2) °C and (50 ± 5) % RH.

Weigh the conditioned test piece and record its mass, m_1 .

Place (50 ± 5) ml of water into the container (see [Figure 35](#)) and place the test piece over the container with the side facing the foot downwards. Place the impermeable disc and the upper ring over the test piece and screw down firmly. Ensure that no water laps against the bottom of the test piece.

Remove the test piece after (480 ± 5) min and weigh immediately, recording its mass, m_2 .

Dimensions in millimetres

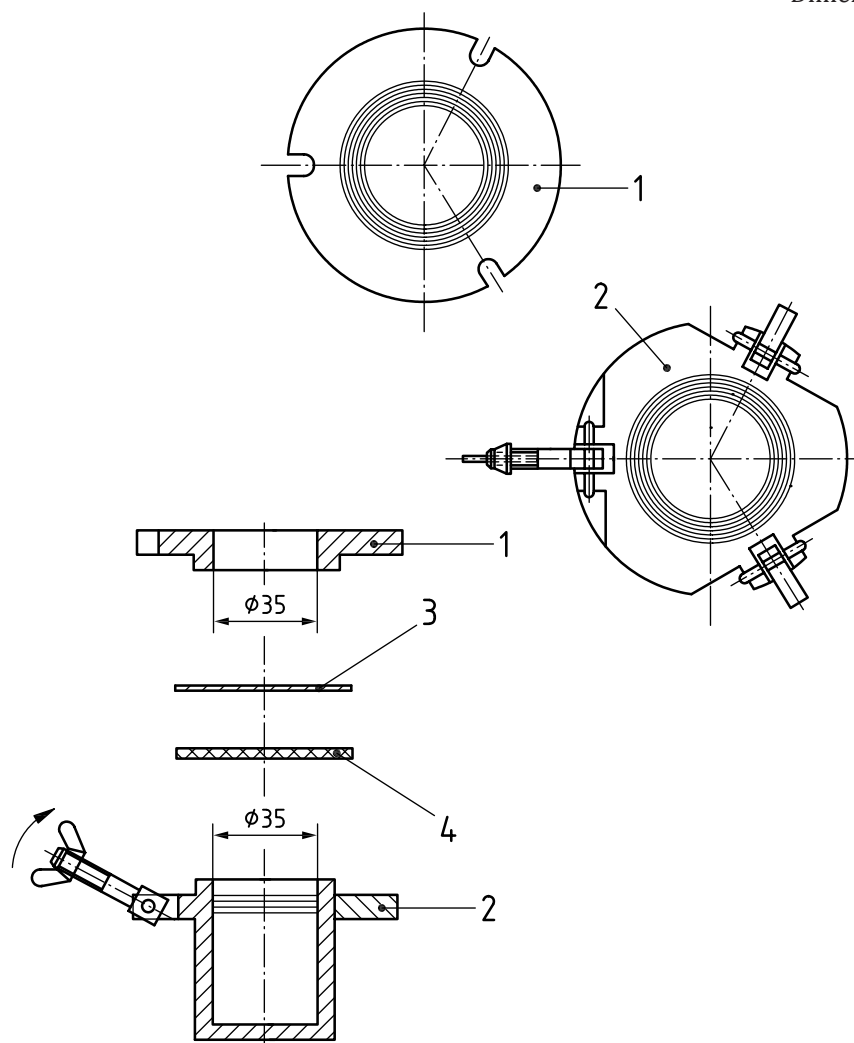

Key

- 1 top
- 2 bottom
- 3 seal
- 4 test piece

NOTE The means of clamping the top to the bottom is illustrative only.

Figure 35 — Apparatus for determination of WVA

6.7.4.3 Calculation and expression of results

Calculate the water vapour absorption using [Formula \(4\)](#):

$$W_1 = \frac{m_2 - m_1}{a} \quad (4)$$

where

W_1 is the water vapour absorption, in mg/cm²;

m_1 is the initial mass of the test piece, in mg;

m_2 is the final mass of the test piece, in mg;

a is the test surface area, in cm².

Round the result to the nearest 0,1 mg/cm².

6.7.5 Test report

The following results shall be reported:

- see [4.4](#);
- WVA for each test pieces;
- the measurement uncertainty (when requested by the customer).

6.8 Determination of water vapour coefficient (WVC)

6.8.1 Calculation of WVC

Calculate the water vapour coefficient using [Formula \(5\)](#):

$$W_2 = 8W_3 + W_1 \tag{5}$$

where

W_2 is the water vapour coefficient, in mg/cm²;

W_3 is the water vapour permeability, in mg/(cm²·h);

W_1 is the water vapour absorption, in mg/cm².

Round the result to the nearest 0,1 mg/cm².

6.8.2 Test report

The following results shall be reported:

- see [4.4](#);
- WVC for each test pieces;
- the measurement uncertainty (when requested by the customer).

6.9 Determination of pH value

6.9.1 Sampling and conditioning

For applicable conditioning, see [4.2](#).

For sampling, see [Table 1](#).

6.9.2 Test method

Determine the pH value of all leathers in accordance with ISO 4045:2018.

6.9.3 Test report

The following results shall be reported:

- see [4.4](#);
- pH value for each leather;
- difference figure, if applicable;
- the measurement uncertainty (when requested by the customer).

6.10 Determination of resistance to hydrolysis of upper

6.10.1 Sampling and conditioning

For applicable conditioning, see [4.2](#).

For sampling, see [Table 1](#).

6.10.2 Test method

Determine the upper hydrolysis in accordance with ISO 5423:1992, Annex B, after preparing and conditioning in accordance with of ISO 5423:1992, Annex E. The test pieces shall include any associated textile layer.

6.10.3 Test report

The following results shall be reported:

- see [4.4](#);
- hydrolysis of upper material;
- the measurement uncertainty (when requested by the customer).

6.11 Determination of chromium VI content

6.11.1 Sampling and conditioning

For applicable conditioning, see [4.2](#).

For sampling, see [Table 1](#).

If the footwear incorporates different types of leather, whether in contact with the skin or not, each leather type shall be tested separately.

6.11.2 Test method

Determine the chromium VI content of all leathers in accordance with ISO 17075-1:2017 or ISO 17075-2:2017.

6.11.3 Test report

The following results shall be reported:

- see 4.4;
- chromium VI value for each leather;
- the measurement uncertainty (when requested by the customer).

6.12 Determination of abrasion resistance of lining and insock

6.12.1 Principle

Circular test pieces are abraded on a reference abradant, under a specified pressure, with a cyclic planar motion in the form of a Lissajous figure (the result of two simple harmonic motions at right angles to each other). The resistance to abrasion is assessed by subjecting the test piece to a defined number of cycles at which point it shall not exhibit any holes.

6.12.2 Test equipment

6.12.2.1 Apparatus

The test apparatus defined in the ISO 12947-1:1998 + Cor. 1:2002 shall be used.

6.12.2.2 Reference abradant²⁾ consisting of a crossbred worsted spun, plain woven fabric, conforming to [Table 14](#).

The reference abradant shall be mounted on the abrading tables over a piece of felt. The felt shall be non-woven felt of mass per unit area (750 ± 50) g/m² and $(2,5 \pm 0,5)$ mm thick. (See ISO 12947-1:1998 + Cor. 1:2002, Table 2.)

NOTE The felt does not need to be renewed until damaged (if the dimensions changes and/or the mass variation imply that the felt does fulfil the requirements of ISO 12947-1:1998 + Cor. 1:2002, Table 2).

Table 14 — Reference abradant

	Warp	Weft
Yarn linear density	R63 tex/2	R74 tex/2
Threads per cm	17	12
Singles twist, turns per metre	540 ± 20 'Z'	500 ± 20 'Z'
Two-fold twist, turns per metre	450 ± 20 'S'	350 ± 20 'S'
Fibre diameter, μm	$27,5 \pm 2,0$	$29,0 \pm 2,0$
Mass per unit area of fabric, minimum g/m ²	195	
Oil content, %	$0,9 \pm 0,2$	

6.12.2.3 Backing for test pieces, having a mass per unit area less than 500 g/m², consisting of polyether urethane foam (3 ± 1) mm thick, of density (30 ± 3) kg/m³ and indentation hardness $(5,8 \pm 0,8)$ kPa, cut to the same size as the test piece. Backings shall be renewed with every test.

2) A suitable reference abradant, felt and polyether urethane foam, may be obtained from SATRA Technology Centre, Northamptonshire, United Kingdom, <http://www.satra.com>. This information is given for the convenience of users of this document and does not constitute an endorsement by ISO of this product.

6.12.2.4 Fabric punch or press cutter, to produce a test piece to fit the holder, having a diameter of 38 mm.

6.12.2.5 Weight, of mass $(2,5 \pm 0,5)$ kg and diameter (120 ± 10) mm.

6.12.2.6 Balance, capable of weighing to the nearest 0,001 g.

6.12.3 Sampling and conditioning

For applicable conditioning, see [4.2](#).

For sampling, see [Table 1](#).

The test pieces shall be taken in the front part of the insocks.

The test-piece thickness shall not be greater than 4 mm. If it is the case, the excess of material shall be removed from the side not in contact with the foot (for example by splitting or abrasion).

6.12.4 Test method

6.12.4.1 Preparation of test pieces and materials

After conditioning, samples shall be tested for each of the 2 conditions dry and wet, coming from different footwear sizes, or from raw material. Using the fabric punch ([6.12.2.4](#)), cut the circular test pieces.

6.12.4.2 Test procedure

6.12.4.2.1 Mounting the test pieces

Remove the outer ring of a test piece holder together with the accompanying metallic insert. Insert the test piece centrally into the outer ring so that the face to be abraded shows through the hole.

For test pieces of fabric which have a mass per unit area of less than 500 g/m^2 , insert a disc of polyether urethane foam ([6.12.2.3](#)) which has the same diameter as the test piece. Use a new backing for each test. Place the metallic insert carefully into the outer ring with its raised surface next to the test piece. Complete the assembly of the test piece holder by screwing on the back plate while pressing the face of the test piece firmly against a hard surface to prevent wrinkling. Check that no wrinkling has occurred. Repeat for remaining test pieces.

6.12.4.2.2 Preparation of abradant and backer for wet test

Thoroughly wet the fabric abradant and felt backer by one of the following methods:

- a) soak overnight;
- b) agitate thoroughly in water;
- c) wet with a high pressure water jet.

Allow excessive water to drain and mount them in accordance with [6.12.4.2.4](#).

Rewet the abradant fabric and felt every 6 400 cycles by gradually pouring on up to 30 ml of water and lightly rubbing it with the fingertips. Place the weight ([6.12.2.5](#)) on the fabric and leave for a few seconds to squeeze out excess water.

6.12.4.2.3 Mounting abradant

Mount a new piece of reference abradant (6.12.2.2) on each table with a piece of felt of the same dimensions beneath the reference abradant. Flatten the reference abradant by placing the weight (6.12.2.5) on its surface, and then position and tighten up the retaining frame evenly. Make sure that the reference abradant is held in place firmly and that there are no tucks or ridges.

6.12.4.2.4 Mounting test piece holders

Mount the test pieces in the machine.

Every time a holder is taken from the machine to check a test piece, re-tighten the holder before it is replaced on the machine.

If during the test pilling occurs, it shall not be cut off.

Perform the test until the intended number of cycles have been performed (25 600 or 51 200 cycles for the dry sample and 12 800 or 25 600 cycles for the wet test). If a hole appears before the expected number of cycles the test can be stopped.

6.12.4.3 Method of assessment, Definition of a hole

This is assessed by the naked eye.

- a) A hole should only be considered as a hole when it extends through the full thickness of the wearing surface
- b) Only new holes (i.e. holes that did not exist before the test) should be considered during the assessment

The various materials types shall be considered to fail when:

Membranes lining: there is a hole in the textile layer.

Double textile (3D): the outer layer (in contact with the foot) develops a hole.

Woven textile: there is a hole or if the threads of one direction break.

Knitted textile: There is a hole or the threads of the base network break. If these base threads do not break, it shall not be considered to fail, even if other threads do.

Textile with pile: there is a hole in the base textile.

Leather: there is a hole through its full thickness.

Coated materials: there is a hole through the full thickness of the coating.

6.12.5 Test report

The following results shall be reported:

- see 4.4;
- abrasion resistance for each sample;
- the measurement uncertainty (when requested by the customer).

6.13 Determination of water penetration and water absorption for upper

6.13.1 Principle

The material is partially immersed in water and flexed on a machine in a manner simulating conditions of wear. Measurements are taken of:

- the percentage gain in mass of the test piece due to water absorption 60 min from the start of the test;
- the mass of water which has passed through the test piece after 60 min of test.

6.13.2 Test equipment

6.13.2.1 Test apparatus,

The test apparatus defined in ISO 5403-1:2011 shall be used.

6.13.2.2 Absorbent cloth, used to absorb water transmitted to the interior of the trough formed by the test piece. The absorbency of the material may not be optimum when new. It shall therefore be washed before the first use.

NOTE A suitable cloth consists of a rectangle of cotton towelling-type textile of approximately 120 mm × 40 mm with a mass of approximately 300 g/m², see ISO 5403-1:2011.

6.13.2.3 Balance, with an accuracy of 1mg.

6.13.2.4 Clock, with an accuracy of within 1 min.

6.13.3 Sampling and conditioning

For applicable conditioning, see [4.2](#).

For sampling, see [Table 1](#).

6.13.4 Test method

6.13.4.1 Preparation of test piece

Cut from the upper a rectangle of (75 ± 1) mm by (60 ± 1) mm. For leather and coated materials, the wear surface shall be buffed by rubbing with a grade 180 emery paper, placing a rigid plate and (10 ± 1) N load on top of it and moving it 100 mm 10 times.

The absorbent cloth shall also be conditioned, as the test piece, prior to use.

In order to avoid leakage of water at the clamps, especially with thin or lightweight materials, apply a layer of adhesive or silicone grease along the edges (covering about 1 to 2 mm of the adjacent faces) to ensure a proper seal.

6.13.4.2 Test procedure

Weigh the test piece to the nearest 0,001 g and record the mass, m_1 .

Adjust the apparatus to give a 7,5 % compression of the test piece.

Fix the test piece in the apparatus, with the outer surface of the upper in contact with the water, as follows.

With the two cylinders at their maximum distance apart, wrap the test piece round their adjacent ends so that it forms a trough whose upper edges, formed by the shorter side of the test piece, are horizontal and at the same level. Keep the test piece between the cylinders under slight tension to remove folds, and with approximately the same length (about 10 mm) overlapping on each cylinder, clamp it using ring clamps. Position the inner edges of the two ring clamps as close as possible in the planes of the adjacent ends of the cylinders, so that the length of the trough is the same as the free length of the test piece between the clamps.

Weigh the absorbent cloth (6.13.2.2), recording its mass, P_1 . Roll it up to form a cylinder of about 40 mm length and immediately place it in the trough formed by the test piece.

Raise the level of water in the tank until water lies about 10 mm below the top of the cylinders.

Start the motor. Stop the motor after (60 ± 2) min.

Remove the absorbent cloth and mop up any surplus water within the trough. Reweigh the cloth. This mass is P_2 .

Remove the test piece from the cylinders, blot to remove adhering water and reweigh. This mass is m_2 .

6.13.4.3 Calculation and expression of results

Calculate the water penetration using the [Formula \(6\)](#):

$$W_p = P_2 - P_1 \quad (6)$$

where

W_p is water penetration, in g;

P_1 is the initial mass of the absorbent cloth, in g;

P_2 is the final mass of the absorbent cloth, in g.

Calculate the water absorption using the [Formula \(7\)](#):

$$W_A = \frac{m_2 - m_1}{m_1} \times 100 \quad (7)$$

where

W_A is the water absorption, as a percentage by mass;

m_1 is the initial mass of the test piece, in g;

m_2 is the final mass of the test piece, in g.

6.13.5 Test report

The following results shall be reported:

- see [4.4](#);
- water penetration and water absorption for each sample;
- the measurement uncertainty (when requested by the customer).

7 Test methods for insole, insock and footbed

7.1 Determination of insole, insock and footbed thickness

7.1.1 Sampling and conditioning

For applicable conditioning, see [4.2](#).

For sampling, see [Table 1](#).

7.1.2 Test method

Cut through the sole in the region of the flexion area (see [Figure 42](#)) and measure the thickness of the insole using a graduated eyepiece with 0,1 mm scale graduations

In case of insole present with non-removable insock, the thickness shall be measured as an insole and insock together

In case of no insole or if present not fulfilling the requirement, the thickness shall be measured on the non-removable insocks.

7.1.3 Test report

The following results shall be reported:

- see [4.4](#);
- insole, insock and footbed thickness for each sample;
- the measurement uncertainty (when requested by the customer).

7.2 Determination of water absorption and desorption of insole and/or insock

7.2.1 Principle

A test piece is positioned on a wet base plate and is submitted to repeat flexing under a given pressure (in the same manner as the insole of a shoe during walking).

The water absorption at the end of test and the water desorption following the tests are determined.

7.2.2 Test equipment

7.2.2.1 Test apparatus

The apparatus described in ISO 22649:2016, method B shall be used.

7.2.2.2 Press knife, to cut test pieces of dimensions (110 ± 11) mm \times (40 ± 1) mm.

7.2.2.3 Balance, with an accuracy of 1mg.

7.2.2.4 Clock, with an accuracy of within ± 1 s.

7.2.2.5 Cotton gauge, with mass/unit area of $(60,5 \pm 10)$ g/m².

7.2.2.6 Silicone grease, or suitable adhesive.

7.2.3 Sampling and conditioning

For applicable conditioning, see [4.2](#).

For sampling, see [Table 1](#).

In the case of footwear, the test piece should be taken from the forepart of the insole, in the longitudinal direction. For sheet materials, the test pieces are taken in the two principal directions, one at 90° to the other.

The water permeability of the insert shall be tested. Place the insert on an absorbent paper and pour 5 ml of water on the insert. If after 60 s, the paper is wet the insert is considered as permeable and [7.2.4](#) will not be performed.

Test pieces shall be strips of $[(110 \pm 11) \times (40 \pm 1)]$ mm. If the test piece is too thick for the clamps, reduce the thickness in the clamping area, removing the face which is not in contact with the foot.

Apply a little silicone grease or a suitable adhesive over the edges of the test piece in order to prevent the ingress of water through the sides.

7.2.4 Test method

7.2.4.1 Test procedure

The tests shall be carried out in a standard atmosphere of (23 ± 2) °C and (50 ± 5) % RH

Weigh the test piece to the nearest 0,001 g (m_0).

Place the cotton gauze on the platform.

Apply the test piece in the apparatus with the surface which would be in contact with the foot in contact with platform covered with the cotton gauze. Attach the narrow ends to the platform and roller and apply a force of (80 ± 5) N.

Open the valve to enable the flow of water and adjust this to $(7,5 \pm 1,0)$ ml/min over the platform.

Switch on the machine and note the time.

Run the test for (60 ± 5) min and stop the water supply 1 min before stopping the machine.

Remove the test piece and weigh it to the nearest 0,001 g, recording its mass, m_F .

Recondition the test piece by leaving it on a flat waterproof surface in a controlled environment (see [Clause 4](#)) for a period of 24 h \pm 30 min, then reweigh the test piece to the nearest 1 mg, m_R .

7.2.4.2 Expression of results

7.2.4.2.1 Water absorption

Calculate the water absorption using the following [Formula \(8\)](#):

$$W_A = \frac{m_F - m_0}{A} \quad (8)$$

where

W_A is the water absorption, expressed in mg/cm²;

m_O is the initial mass of the test piece, in mg;

m_F is the final mass of the test piece, in mg;

A is the area of the test piece in cm².

Express the water absorption to the nearest 1 mg/cm².

7.2.4.2.2 Water desorption

Calculate the water desorption using the following [Formula \(9\)](#):

$$W_D = \frac{m_F - m_R}{m_F - m_O} \times 100 \quad (9)$$

where

W_D is the water desorption, as a percentage of the mass of water absorbed;

m_O is the initial mass of the test piece, in g;

m_F is the final mass of the test piece in g;

m_R is the mass of the reconditioned test piece in g.

Report the water desorption to the nearest 1 %.

7.2.5 Test report

The following results shall be reported:

- see [4.4](#);
- the results for water absorption and water desorption expressed in accordance with [7.2.4.2.1](#) and [7.2.4.2.2](#);
- the measurement uncertainty (when requested by the customer).

7.3 Determination of abrasion resistance of insole

7.3.1 Principle

The test piece is rubbed with pieces of wet, white wool felt, covered with the abradant fabric, under a given pressure, with a number of to-and-fro motion cycles. The test is carried out on conditioned insole material, and abrasion damage is assessed by measuring the change in thickness of the insole.

7.3.2 Test equipment

7.3.2.1 Apparatus and wool pads, as described in ISO 11640:2018 shall be used.

7.3.2.2 Abradant fabric. Cut pieces of fabric of the specification given in [Table 14](#) of a dimension sufficient to cover the felt and to attach it to a finger.

7.3.2.3 Thickness gauge, in accordance with Method A in ISO 23529:2016, 7.1, with a flat presser foot of $(10 \pm 0,1)$ mm diameter and a pressure of (10 ± 2) kPa.

7.3.3 Sampling and conditioning

Applicable conditioning see [4.2](#).

Condition the wool pads ([7.3.2.1](#)) and pieces of abradant fabric ([7.3.2.2](#)) at (23 ± 2) °C and (50 ± 5) % RH for 24 h

For sampling see [Table 1](#).

7.3.4 Test method

7.3.4.1 Preparation of test piece

7.3.4.1.1 Cut a rectangle of minimum dimensions 100 mm × 20 mm.

Measure the initial thickness, e_i , of the insole according to [7.1](#).

7.3.4.1.2 Preparation of abradant pads

After conditioning of the wool pads ([7.3.2.1](#)) weigh the wool pads.

For each test piece place four wool pads and four rectangles of abradant fabric in distilled water, heat to boiling and allow to boil gently until they sink. Then decant the hot water and replace with cold, distilled water. Leave until the wool pads and abradant fabric have reached room temperature.

Before use, take each pad and abradant fabric from the water, squeeze or wipe it against the rim of the beaker so that it no longer drips. The pads should not be allowed to soak in water for more than 24 h before use.

Verify that the water uptake of the pad is $(1,0 \pm 0,1)$ g by weighing.

7.3.4.2 Test procedure

Fasten the test piece onto the apparatus and apply a slight tension to hold it flat.

Attach a wet wool pad to the finger, cover with a rectangle of wet abradant fabric and secure it to the finger with e.g. a rubber band or ring, avoiding any crease in the fabric over the surface of the wool pad. Place the finger 5 mm from one edge of the test piece. Attach the additional mass of 500 g to the finger.

Every 100 cycles, stop the test and lift the finger. Replace the wool pad and abradant fabric with fresh ones and carry out a further 100 cycles. Stop the test after 400 cycles.

7.3.4.3 Method of assessment

Cut through the abraded area. Measure the minimum thickness in the abraded area, e_f , according to [7.1](#) and calculate the variation of thickness in % V_e , as given by [Formula \(10\)](#):

$$V_e = (e_f - e_i) \cdot 100 / e_i \quad (10)$$

where

e_i is the initial thickness;

e_f is the final thickness;

V_e is the variation of thickness in %.

7.3.5 Test report

The following results shall be reported:

- see [4.4](#);
- the results in % of the thickness variation for each sample;
- the measurement uncertainty (when requested by the customer).

8 Test methods for outsole

8.1 General remarks

Preparation of test pieces:

- From multilayer soles: Test-pieces shall be obtained in the thickness indicated in each test, either of one single material if the thickness of the sole allows it (outsole), or of two materials (outsole + midsole) if there is not enough thickness in the outsole.
- From soles with cavities: Test-pieces shall be obtained in the indicated thickness in each test and, if that is not possible, in the available thickness

All outsole tests shall be carried out on the materials in contact with the ground during the footwear use excepting fuel oil resistance in which all visible materials from the underside outsole shall be tested.

8.2 Determination of outsole dimensions

8.2.1 Sampling and conditioning

Preconditioning of the footwear is not required.

For sampling, see [Table 1](#).

8.2.2 Determination of the cleated area

8.2.2.1 Test method

By means of visual examination check whether, with the exception of the region under the flange of the toecap, at least the shaded areas as shown in [Figure 36](#) have cleats that are open to the side.

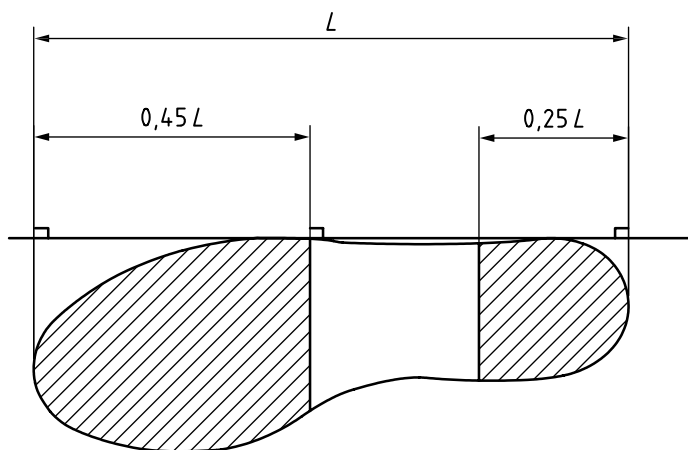

Figure 36 — Cleated area

8.2.2.2 Test report

The following results shall be reported:

- see [4.4](#);
- record the presence of cleat open to the side in the shaded area (see [Figure 36](#));
- the measurement uncertainty (when requested by the customer).

8.2.3 Outsole thickness and cleat height

8.2.3.1 Test method

Measure the thickness, d_1 , and cleat height, d_2 , as indicated in [Figure 37](#) a), b) or c), [Figure 38](#) or [Figure 39](#), using an adequate instrument with 0,1 mm scale/graduation, after cutting through the sole in the region of the tread corresponding to the shaded area in [Figure 36](#). If there is a cavity in the sole it is ignored when measuring d_1 . For all-rubber and all-polymeric footwear, make an additional measurement, d_3 , as indicated in [Figure 39](#).

If the footwear outsole design is according to [Figure 40](#), measure d_4 .

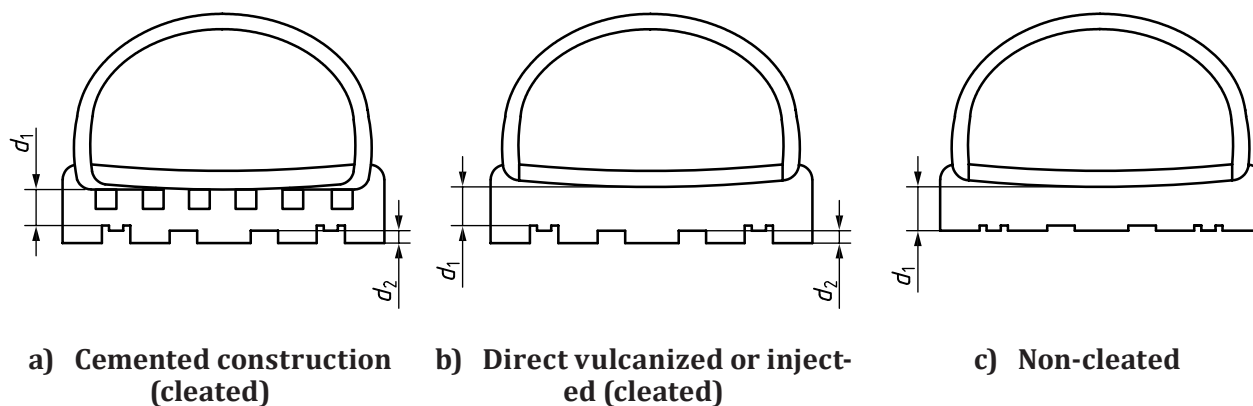

Figure 37 — Direct injected, vulcanized and cemented outsoles

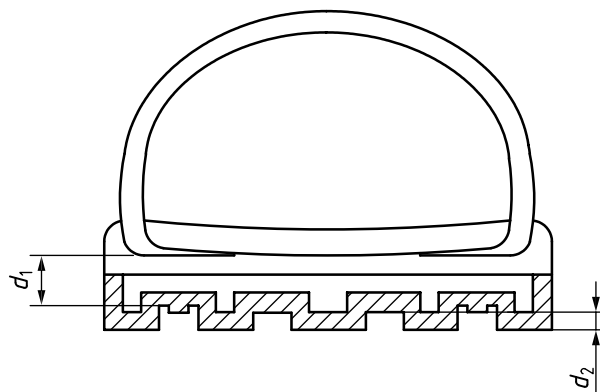

Figure 38 — Multi-layered outsoles (cleated)

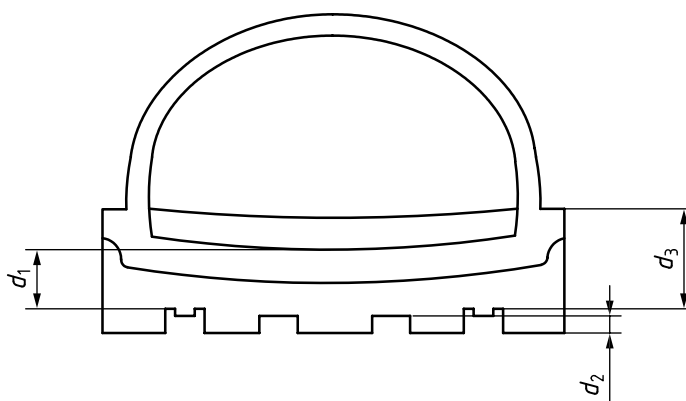

Figure 39 — All-rubber and all-polymeric footwear (cleated)

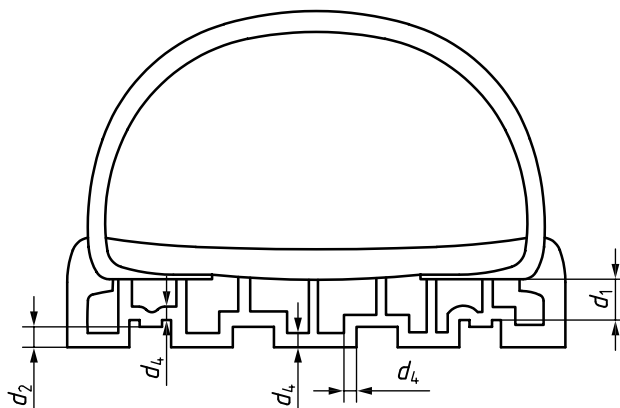

Figure 40 — Cemented footwear (minimum thickness)

8.2.3.2 Test report

The following results shall be reported:

- see [4.4](#);
- depending on the type of outsole, d_1 , d_2 , d_3 and d_4 ;
- the measurement uncertainty (when requested by the customer).

8.2.4 Determination of cleat design in the waist area

8.2.4.1 Test method

Taking into account [Figure 41](#), measure:

- the distance “ a ” in the waist area
- the angle “ α ”
- the dimension “ b ”
- the cleat height in the waist area “ d ”

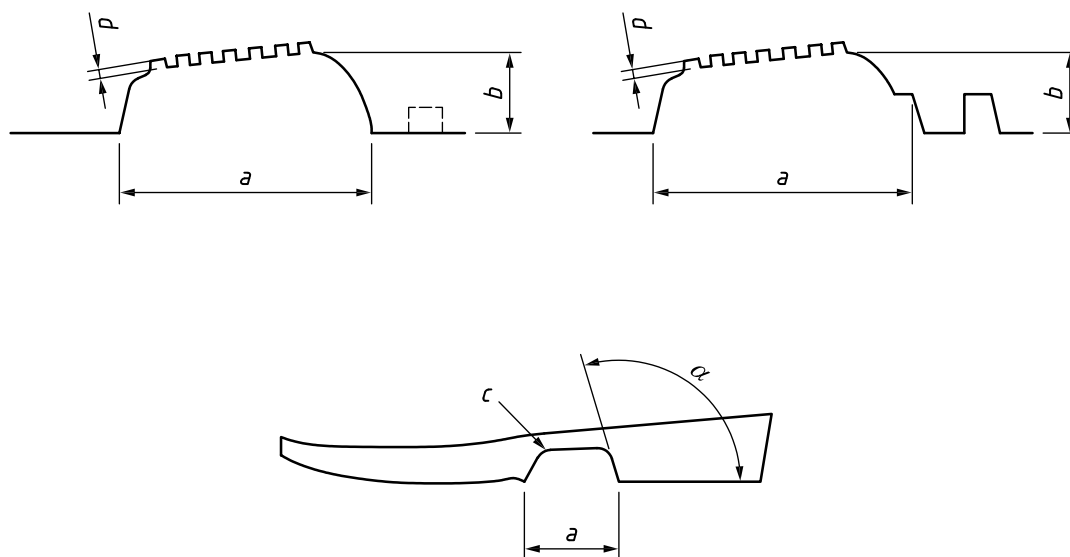

Key

- a waist area
- α angle of the heel breast
- b heel breast
- c cleat profile
- d cleat height in the waist area

Figure 41 — Example of ladder grip outsole

8.2.4.2 Test report

The following results shall be reported:

- see [4.4](#);
- the distance “ a ” in the waist area;
- the angle “ α ” of the heel breast;
- the dimension “ b ” heel breast height;
- the cleat height in the waist area “ d ”;
- the measurement uncertainty (when requested by the customer).

8.3 Determination of tear strength of outsole

8.3.1 Sampling and conditioning

For applicable conditioning, see [4.2](#).

For sampling, see [Table 1](#).

8.3.2 Test method

Determine the tear strength of non-leather outsoles in accordance with ISO 34-1:2015, Method A

The test piece shall be taken transverse to the longitudinal axis, preferably in an area without cleat (for example the waist region).

8.3.3 Test report

The following results shall be reported:

- see [4.4](#);
- the outsole tear resistance;
- the measurement uncertainty (when requested by the customer).

8.4 Determination of outsole abrasion resistance

8.4.1 Sampling and conditioning

For applicable conditioning, see [4.2](#).

For sampling, see [Table 1](#).

8.4.2 Test method

Determine the outsole abrasion resistance of non-leather outsoles in accordance with ISO 4649:2017, Method A (with a vertical force of 10 N over an abrasion distance of 40 m). Test pieces may be taken from anywhere on the outsole.

8.4.3 Test report

The following results shall be reported:

- see [4.4](#);
- the outsole abrasion resistance;
- appearance of hole(s) in the outer layer of the sole material;
- the measurement uncertainty (when requested by the customer).

8.5 Determination of footwear rigidity

8.5.1 Principle

This test will be used as a screening test to decide whether the determination of flexing resistance of the outsole (see [8.6](#)) has to be performed.

8.5.2 Test equipment

8.5.2.1 **Smooth metal hinged plate**, fixed to a rigid base.

8.5.2.2 **Clamping device**, to fix the forepart of the footwear to be tested to the rigid base.

8.5.2.3 **Sensor**, capable of measuring force in the range 0 N to 50 N, to a tolerance of $\pm 1\%$, fixed to the hinged plate at a distance of (315 ± 3) mm from the hinge.

8.5.3 Sampling and conditioning

For applicable conditioning, see [4.2](#).

For sampling, see [Table 1](#).

8.5.4 Test method

8.5.4.1 Preparation of test pieces

Use one complete item of footwear as the test piece. The middle size of the range should be selected. This will normally be European size 42 or 39 (see [Annex B](#)).

Mark the longitudinal axis of the footwear, XY, following the method described in [5.4.3.1](#).

The flexing line is defined as the line at 90° to the longitudinal axis passing through it at one third of the distance XY from the toe at X. The flexing line is AC. Then draw 2 lines parallel to AC at $(5 \pm 0,5)$ mm each, defining the flexing area (width (10 ± 1) mm) (see [Figure 42](#)).

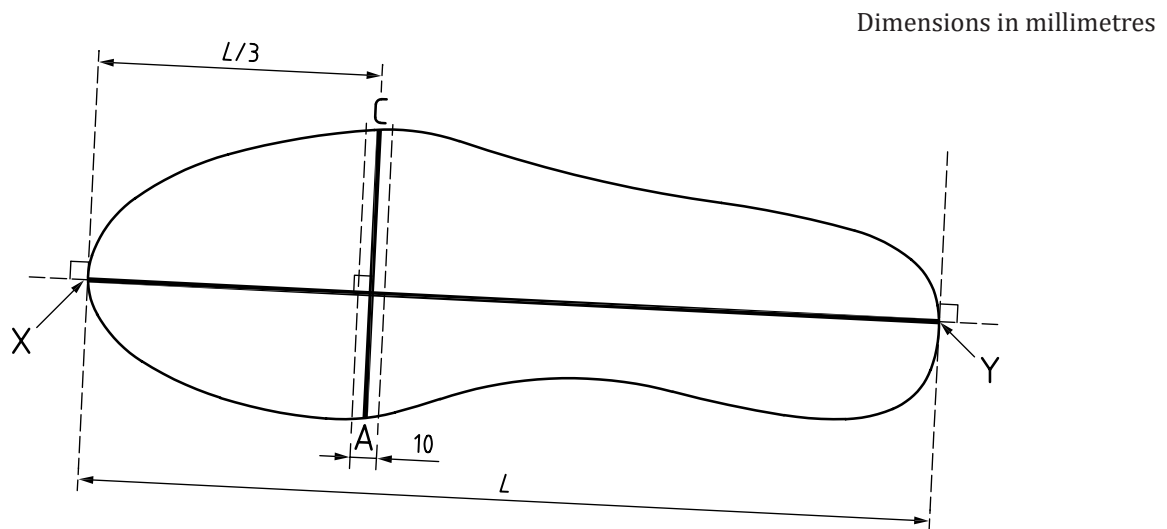

Figure 42 — Position of flexing line on the sole

8.5.4.2 Test procedure

Clamp the forepart of the footwear to the rigid base using a solid block (corresponding to the forepart of the last) in such a way that the flexing area is aligned with the hinge axis of the base plate ([8.5.2.1](#)) (see [Figure 43](#)).

The rear edge of the block shall be positioned 10 mm forward of the flexing line (A-C as shown in [Figure 43](#)).

It is possible that when the front part of the shoe is fixed the heel will not touch the plate.

If this is the case move the plate until contact is made with the heel block, then zero the angle measuring device in this position.

Measure the flexed angle when a force of $(30 \pm 0,5)$ N is applied normal to the plane of the hinged plated (8.5.2.1) at a distance of 315 mm from the centre of the hinge (see Figure 44).

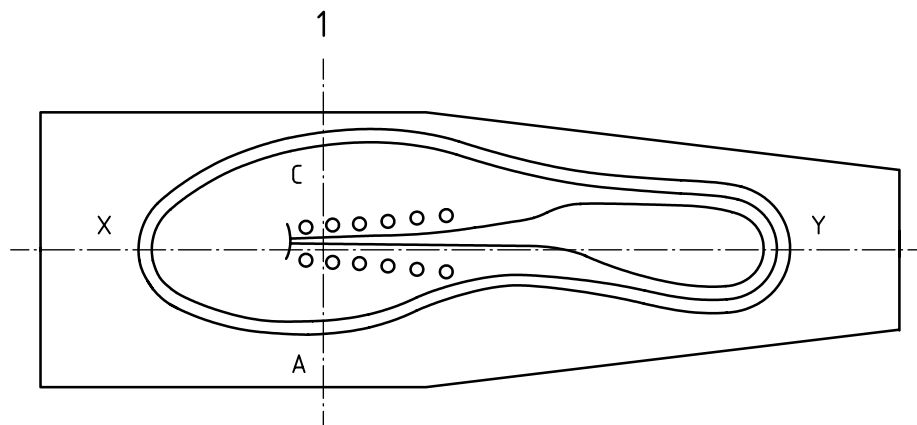

Key

1 flex line

Figure 43 — Position of the footwear on the testing machine

Dimensions in millimetres

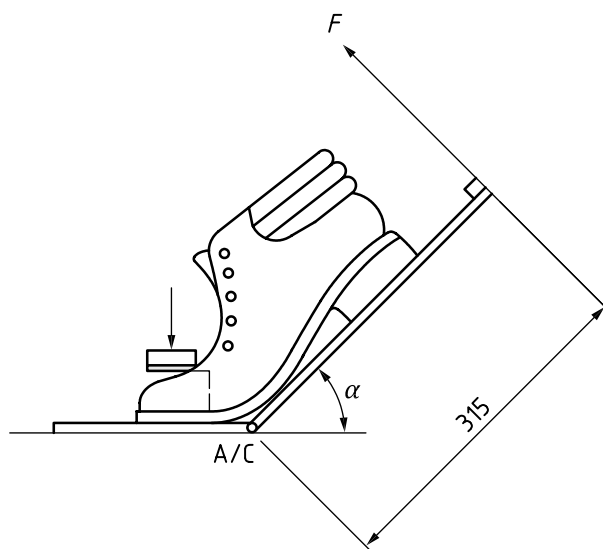

Key

A/C flexing line

F force of $(30 \pm 0,5)$ N

1 flex angle

Figure 44 — Flexing angle

Flex the sole so that the centre of the hinge is moved at a speed of (100 ± 10) mm/min until a force of $(30 \pm 0,5)$ N has been exerted. Measure the angle at this point.

Lubricant can be added under the heel to facilitate the test.

8.5.5 Test report

The following results shall be reported:

- see [4.4](#);
- the flexion angle at 30 N;
- the measurement uncertainty (when requested by the customer).

8.6 Determination of flexing resistance of outsole

8.6.1 Principle

When tested according to the footwear rigidity test (see [8.5](#)), footwear whose angle under the applied force is lower than 45° from the horizontal is not subjected to the flexing test described in [8.6](#).

8.6.2 Test equipment

8.6.2.1 Apparatus

The apparatus described in ISO 17707:2005 shall be used.

8.6.2.2 Cutting tool, as defined in ISO 17707:2005, 4.4.

8.6.2.3 Measuring magnifier, with an accuracy of 0,1 mm.

8.6.3 Sampling and conditioning

For applicable conditioning, see [4.2](#).

For sampling, see [Table 1](#).

8.6.4 Test method

8.6.4.1 Preparation of the test piece

Take the bottom of the footwear with the insole, separated from the upper, as the test piece.

Define the flexing line in accordance with [8.5.4.1](#).

Mark a point, for the later insertion of a cut, as follows:

Find the centre of the line AC, and then identify two adjacent cleats that are as close as possible to the centre of the line AC. Mark the sole midway between these cleats (see [Figure 45](#)).

8.6.4.2 Test method

The tests shall be carried out in a standard atmosphere of (23 ± 2) °C.

Ensure that the testing device ([8.6.2.1](#)) is at the neutral flex position (see ISO 17707:2005, Figure 2) and clamp the test piece into the device in such a way that the flexing line AC is parallel with the central roller and the cut position marked [8.6.4.1](#) is directly above the centre roller. If the sole unit is naturally curved, the clamping procedure shall be carried out so that the sole comes close to the centre roller under no load. Manipulate the machine until the test piece is in the maximum flexed, extended or stretched state. Make a single incision at the point marked in [8.6.4.1](#) with the blade of the cutting tool ([8.6.2.2](#)) parallel to the flexing line AC. The cutting device shall pass through the full thickness of the

outsole and into the insole or equivalent layer. If the product contains a perforation resistant insert, only cut until contact with this is made.

When the tread surface in the flexing area is constituted of several materials, for each material an incision shall be made, avoiding the region of 15 mm from the edge of the sole.

Measure the initial length of the cut at the surface of the test piece using the measuring magnifier (8.6.2.3).

Carry out 30 000 cycles starting from the maximum flexed, extended or stretched state, with the test piece undergoing deformation at a constant rate value between 135 cycles/min and 150 cycles/min.

At completion of the 30 000 cycles, the testing device should not be left in the fully flexed position.

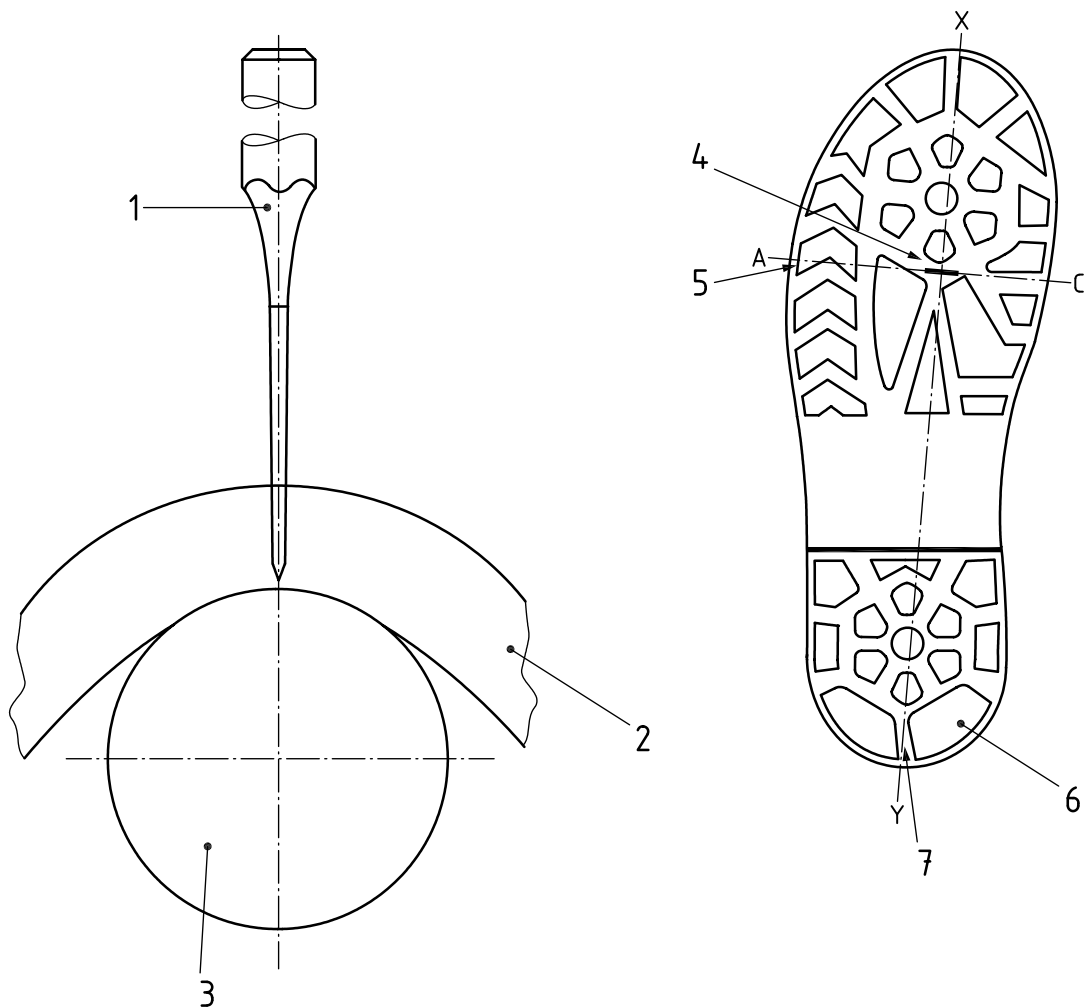

Key

- 1 cutting tool
- 2 test piece
- 3 mandrel of the test machine, radius 15 mm
- 4 single incision on the line of maximum stress
- 5 auxiliary line AC, parallel or on the line of maximum stress
- 6 cleats
- 7 longitudinal axis XY

Figure 45 — Outsole incision

After 30 000 cycles, measure the final length of the cut at the surface of the test piece using the measuring magnifier (8.6.2.3). Measurements before and after the applied cycles has to be done at the same position, the maximum flex position.

The number and dimensions of spontaneous cracks shall be recorded if present.

Cut growth = (final cut length) – (initial cut length).

8.6.5 Test report

The following results shall be reported:

- see 4.4;
- the number of flexing cycles, 30 000;
- the cut growth;
- number and dimension of spontaneous cracks;
- any damage of the metallic insert, if present;
- the measurement uncertainty (when requested by the customer).

8.7 Determination of resistance to hydrolysis of outsole

8.7.1 Sampling and conditioning

For applicable conditioning, see 4.2.

For sampling, see Table 1.

8.7.2 Test method

Determine the outsole hydrolysis in accordance with ISO 5423:1992, Annex C, after preparing and conditioning as described in of ISO 5423:1992, Annex E. The test pieces shall include any associated textile layer, have a thickness of $(3 \pm 0,2)$ mm and be preconditioned at (23 ± 2) °C, before flexing test.

8.7.3 Test report

The following results shall be reported:

- see 4.4;
- result of the test to outsole hydrolysis;
- the measurement uncertainty (when requested by the customer).

8.8 Determination of resistance to fuel oil

8.8.1 Sampling and conditioning

For applicable conditioning, see 4.2.

For sampling, see Table 1.

8.8.2 Test methods

8.8.2.1 General method

8.8.2.1.1 Test liquid

2,2,4-trimethylpentane, general purpose reagent.

8.8.2.1.2 Preparation of the test piece

All visible outer material from the underside outsole shall be tested.

Cut from the outsole two cylindrical pieces (16 ± 1) mm in diameter and ($4 \pm 0,5$) mm in thickness. Test both pieces at the same time.

8.8.2.1.3 Test procedure

Follow the general procedure described in ISO 1817:2015, 8.3.

Immerse the test piece in the test liquid ([8.8.2.1.1](#)) at a temperature of (23 ± 2) °C for a period of ($22 \pm 0,25$) h. Determine the increase in volume of each test piece using the volumetric method.

If the test piece shrinks by more than 1,0 % or increases in hardness by more than 10 Shore A hardness units, determined using the method described in ISO 868:2003, take a further test piece, as described in [8.8.2.2.2](#) and test as described in [8.8.2.2.3](#).

8.8.2.2 Method for outsole materials which shrink or become hardened

8.8.2.2.1 Test liquid

The test liquid shall be as described in [8.8.2.1.1](#).

8.8.2.2.2 Preparation of the test piece

Take a test piece of nominal width 25 mm and nominal length 150 mm from the outsole of the footwear and reduce the overall thickness to ($3 \pm 0,2$) mm by roughing or scouring.

8.8.2.2.3 Test procedure

Immerse the test piece in the test liquid at a temperature of (23 ± 2) °C for a period of ($22 \pm 0,25$) h.

Remove the excess liquid with absorbent paper and determine the cut growth in the test piece after 150 000 cycles in accordance with the method described in ISO 4643:1992, Annex C

8.8.3 Test report

The following results shall be reported:

- see [4.4](#);
- resistance to fuel oil;
- the measurement uncertainty (when requested by the customer).

8.9 Determination of resistance to hot contact

8.9.1 Test equipment

NOTE A general arrangement of the apparatus is illustrated in [Figure 46](#).

WARNING — As toxic fumes might be released from some soling during this test, it is necessary to place the apparatus in a well-ventilated area.

8.9.1.1 Cylindrical copper body, referred to as the bit, of mass (200 ± 20) g and with the lower end reduced to a flat square with sides of dimensions $(25,5 \pm 0,1)$ mm. The bit shall have a central longitudinal cavity of $(6,5 \pm 0,5)$ mm diameter, extending to $(4 \pm 0,5)$ mm from the outer working surface of the end square of the bit, to receive a temperature measuring device. The other dimensions of the bit shall be as shown in [Figure 46](#).

8.9.1.2 Metal heating block, of mass (530 ± 50) g, which surrounds the cylindrical part of the bit. The heating block shall contain an electrical resistance heating element and a means of control (an on/off switch is sufficient)

8.9.1.3 Heating element to pre-heat the bit to any desired temperature up to a maximum of 400 °C. The dimensions of the heating block shall be as shown in [Figure 47](#).

8.9.1.4 Measuring device, for the internal temperature of the bit close to its square end.

8.9.1.5 Means of raising and lowering the bit, together with the heating block, to bring its face into uniform contact with the test piece, in a horizontal plane and under a uniformly distributed pressure of (20 ± 2) kPa.

8.9.1.6 Self-aligning platform, of suitable diameter, to receive the test piece and maintain uniform pressure on it.

8.9.1.7 Hinged support with thermally insulated face, on which the face of the bit rests during heating, and which can be moved aside to enable the bit to be lowered onto the test piece.

8.9.1.8 Mandrel, of (10 ± 1) mm diameter.

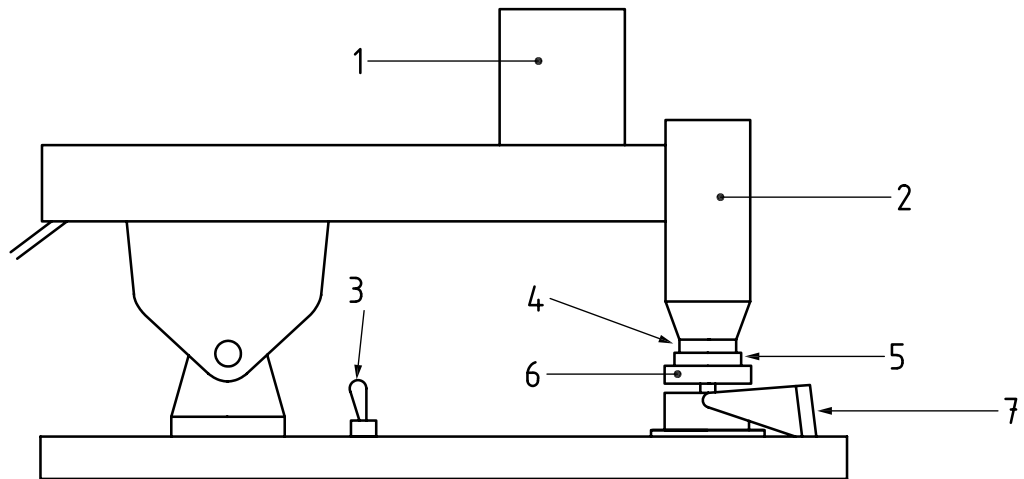

Key

- 1 weight
- 2 encased heating block including device for measuring temperature
- 3 on/off switch
- 4 square end of copper bit
- 5 soling test piece
- 6 self-aligning test piece platform
- 7 hinged insulated support

Figure 46 — Example of apparatus for determination of resistance to hot contact

Dimensions in millimetres

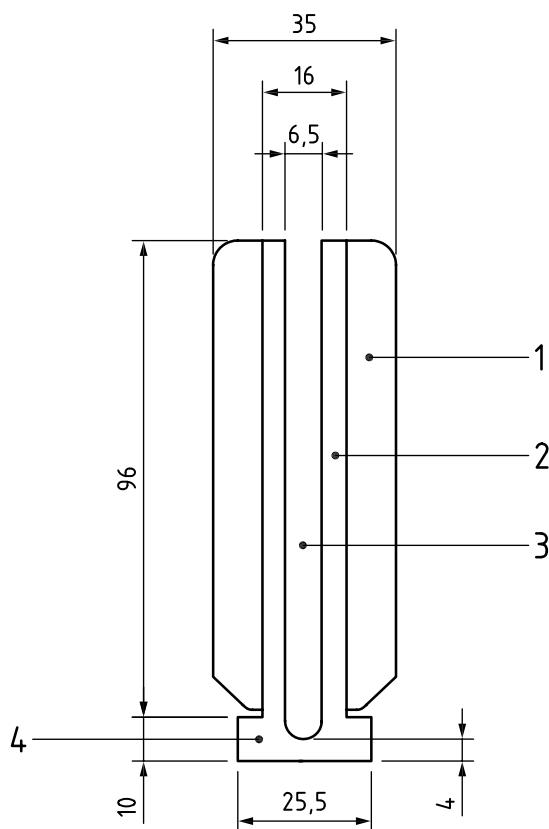

Key

- 1 metal heating block
- 2 copper bit
- 3 device for measuring the temperature
- 4 square end of bit

Figure 47 — Bit and heating block

8.9.2 Sampling and conditioning

For applicable conditioning, see [4.2](#).

For sampling, see [Table 1](#).

8.9.3 Test methods

8.9.3.1 Preparation of the test piece

Cut a test piece of width (30 ± 2) mm and length 70 mm (minimum) from the outsole and, where necessary, remove the cleats.

The test may be carried out in the waist region if the sole material is the same in this region as the wearing tread area. If this is not possible; and the removal of the cleats would result in the removal of the wear layer, it may be necessary to obtain flat test pieces from alternative sole patterns to enable the test to be carried out.

8.9.3.2 Test procedure

Switch on the heating block with the bit resting on the insulating support and place the test piece on the platform below with its wear side uppermost. Cover the test piece with aluminium foil to prevent contamination of the heated bit, using a new piece of foil for each test. When the bit temperature has just exceeded 300 °C switch off the heating block and allow the temperature to fall to (300 ± 5) °C measured on the outer plate, with the bit still resting on its insulating support. Then move the insulating support aside and immediately place the bit centrally on the test piece, so its sides are parallel to the side of the test piece. Leave it in position for (60 ± 1) s without switching the heating block on again and then replace it on the support.

Remove the foil, allow the test piece to cool for at least 10 min and examine that part of its surface which had been heated as described in [8.9.3.3](#).

8.9.3.3 Method of assessment

Assess the surface of the test piece visually for damage such as melting, charring, cracking or crazing, both before and after bending it around the mandrel. Record the type and extent of the damage. For leather outsoles, record whether charring or cracking is confined to the grain layer or whether any damage penetrates into the corium.

8.9.4 Test report

The following results shall be reported:

- see [4.4](#);
- any degradation of the outsoles;
- the measurement uncertainty (when requested by the customer).

Annex A (informative)

Assessment of footwear by the laboratory during testing of thermal behaviour

A.1 General

The following list and drawings are provided to assess the performance of the footwear when thermal behaviour is tested in accordance with [5.15](#).

A.2 Criteria for the assessment of the state of footwear after test for insulation against heat

After testing in accordance with [5.15](#), when the footwear is at the ambient temperature, if the following signs of degradation are detected they shall be reported:

- cracks on the outsole greater than 10 mm long or 3 mm deep (see [Figure A.1](#));
- upper/outsole separation of more than 15 mm long or 5 mm wide (deep) (see [Figure A.2](#));
- delamination of the soling materials (see [Figure A.3](#)).
- pronounced deformation and cracks on the insole and insock (if any) greater than 10 mm long and deeper than the half material thickness;
- pronounced deformation of the outsole due to any of the following causes (see [Figure A.4](#))
 - joining of 2 or more cleats due to the material melting
 - decrease in the cleat height to less than half of the initial height
 - melting of the outside of the cleat and the midsole becomes visible
- Beginning of pronounced and deep cracking affecting half of the upper material thickness (see [Figure A.5](#))
- The upper shows areas with deformations or split seams causes (see [Figure A.6](#))

To assess the two last points, the ergonomic tests described in ISO 20345:2021, 5.3.4 can be used.

Dimensions in millimetres

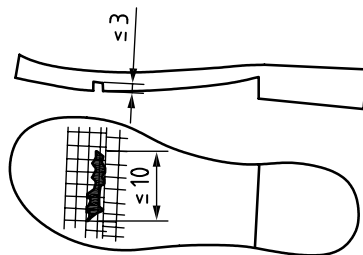

Figure A.1 — Cracks in outsole

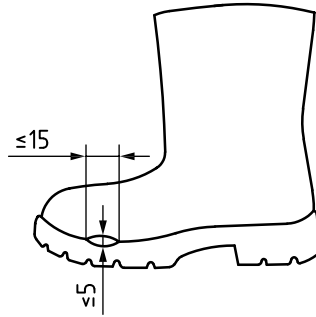

Figure A.2 — Upper/outsole separation



Figure A.3 — Delamination of the sole



Figure A.4 — Pronounced deformation

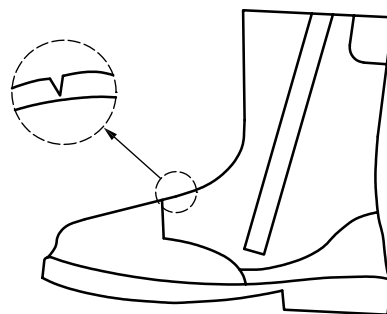

Figure A.5 — Deep cracks in the upper

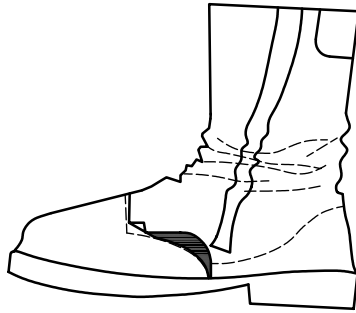

Figure A.6 — Separation of upper material, broken seams

Annex B (informative)

Footwear sizes

[Table B.1](#) gives the corresponding values between several sizing systems.

Table B.1 — Nominal size conversion from European sizing to other sizing systems
 (based on ISO/TS 19407:2015)

European	UK	Mondopoint
36 and below	≤4	≤225
37 and 38	4,5 to 5,5	230 to 240
39 and 40	6 to 7	245 to 255
41 and 42	7,5 to 8,5	260 to 270
43 and 44	9 to 10	275 to 280
45 and above	≥10,5	≥285

Bibliography

- [1] ISO 868:2003, *Plastics and ebonite — Determination of indentation hardness by means of a durometer (Shore hardness)*
- [2] ISO 5402-1:2017, *Leather — Determination of flex resistance — Part 1: Flexometer method*
- [3] ISO 5725-2, *Accuracy (trueness and precision) of measurement methods and results — Part 2: Basic method for the determination of repeatability and reproducibility of a standard measurement method*
- [4] ISO/TS 19407:2015, *Footwear — Sizing — Conversion of sizing systems*
- [5] ISO/IEC Guide 98-1, *Uncertainty of measurement — Part 1: Introduction to the expression of uncertainty in measurement*
- [6] ISO/IEC Guide 98-4, *Uncertainty of measurement — Part 4: Role of measurement uncertainty in conformity assessment*
- [7] JCMG 100 Evaluation of measurement data – guide to the expression of uncertainty in measurement (published by the bureau international des poids et mesures – BIPM).
- [8] EN 15090, *Footwear for firefighters*

Personal protective equipment — Test methods for footwear

AMENDMENT 1

4.2

Replace the 2nd paragraph by:

"If the test requires a defined condition (temperature (23 ± 2) °C and/or (50 ± 5) % RH), it is mentioned in the test method. Where the testing in conditioned atmosphere is not required, the maximum time which shall elapse between removal from the conditioning atmosphere and the start of testing shall not be greater than 10 min, unless otherwise stated in the test method."

Table 1

Replace the text of the 4th line by:

Toecap dimensions	B	No	5.3	3 pairs of footwear or toe-caps in sizes S-M-L	1 pair of toecaps
-------------------	---	----	-----	--	-------------------

Replace the text of the 23th line by:

Ankle protection	A	Yes	5.22	3 footwear in sizes S-M-L	For each footwear 1 test piece (outer) and 1 test piece inner (if claimed)
------------------	---	-----	------	---------------------------	---

Replace the text of the 28st line by:

Height of the upper	B	Yes	6.2.2	3 pairs of footwear in sizes S-M-L	Item of footwear
Area for non-water vapor permeable materials	B	Yes	6.2.3	1 item of footwear size M	1 test piece

Replace the text of the 31st line by:

Flexing resistance	B	Yes	6.5	3 items of footwear in different sizes	1 test piece
--------------------	---	-----	-----	--	--------------

Replace the text of the 37th line by:

Abrasion resistance of lining	B	No	6.12	footwear or materials	2 test pieces, wet 2 test pieces, dry
-------------------------------	---	----	------	-----------------------	--

Replace the text of the 44th line by:

Abrasion resistance of insock	B	No	6.12	3 items of footwear in different sizes or 3 samples of the relevant components	1 test piece, wet 1 test piece, dry
-------------------------------	---	----	------	--	--

Figure 1

Replace Figure 1 by:

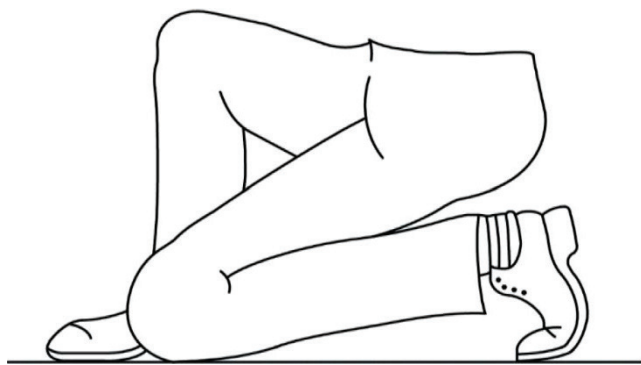

a) Position to adopt during the kneel/crouch down test

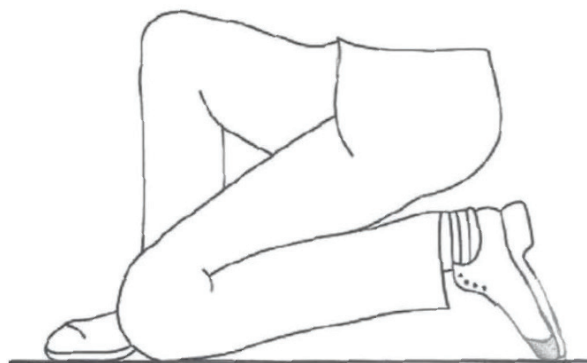

b) Position to adopt during the kneeling for scuff cap checking

Figure 1 — Position to adopt during the kneel/crouch down test

5.1.2, Table 2

Add the following line at the end of the existing table:

	4.4 During kneeling, the scuff cap prevents the contact of the upper with the ground	YES	NO
--	--	-----	----

5.1.3

Replace the text of 5.1.3 by:

"The following results shall be reported:

- see 4.4;
- for each tested size, either all positive answers or any failing result.

The determination of measurement uncertainty is not applicable."

5.2.4.3

Replace text of the 2nd sentence of the 1st paragraph by:

"All sole materials in this area shall be tested, see Figure 2."

5.5.3.3

Replace text of the 1st paragraph by:

"Position a cylinder (5.4.1.3) on one of its ends inside the test piece as shown in Figure 13 and 14. Place the test piece in the clamping device (5.4.1.2) and adjust to align the test axis of the test piece with the centre line marked on the clamping device."

5.7.4

Replace the text of 5.7.4 by:

"The following results shall be reported:

- see 4.4;
- for each tested size, detection of air leakage.

The determination of measurement uncertainty is not applicable."

5.10.4.1

Replace text of the 2nd paragraph by:

"If the non-metallic perforation-resistant insert type PL is not used as an insole (e.g. in a Strobel), the test shall be conducted in accordance 5.9.3."

5.10.5

Replace the text of 5.10.5 by:

"The following results shall be reported:

- see 4.4;
- for each tested size, left and right, results of 5.10.4.2.1 or 5.10.4.2.2
- Note any "tent effect";
- The measurement uncertainty for PS (when requested by the customer).

The determination of measurement uncertainty for PL is not applicable."

5.11.3

Replace the text of 5.11.3 by:

"The following results shall be reported:

- see 4.4;
- all results as defined in the relevant used standard.

The determination of measurement uncertainty is not applicable."

5.12.3

Replace the text of 5.12.3 by:

"The following results shall be reported:

- see 4.4;
- all results as defined in the relevant used standard.

The determination of measurement uncertainty is not applicable."

5.15.4

Replace the text of the 7th hyphen by:

"— the description of any damage that can seriously affect the functionality of the footwear (e.g. beginning of separation of upper and sole) applying Annex A or any other requirement of other standard (for example ISO 20349-2:2017+Amd 1:2020);"

5.18.1

Replace the 2nd sentence of the 1st paragraph by:

"The water penetration is determined by examination."

5.18.4.2

Replace the 1st paragraph by:

"With the empty trough, position the turning platforms so that the tester takes 11 paces walking from one to the other with a normal length stride (i.e. so that each foot is placed on the floor of the trough five times). Fill the trough up to a depth of (30 ± 3) mm with water for class I footwear. Fill the trough for hybrid footwear up to a height of 10 mm above H (as defined in ISO 20345:2021 Figure 6 and Table 8)."

5.18.5

Replace the text of 5.18.5 by:

"The following results shall be reported:

- see 4.4;
- for each tested size, left and right, any water penetration.

The determination of measurement uncertainty is not applicable."

5.19.4.2.7

Replace the text of the 2nd hyphen by:

"— For hybrid footwear, up to a height of 10 mm above H (as defined in ISO 20345:2021 Figure 6 and Table 8)."

5.19.5

Replace the text of 5.19.5 by:

"The following results shall be reported:

- see 4.4;
- for each tested size, left and right, any water penetration.

The determination of measurement uncertainty is not applicable."

5.20.1.4.3

Replace the full text by:

5.20.1.4.3 Production of wax forms using footwear involves a 2 stages operation, the first of which is to produce a plaster of Paris cast of the inside of the footwear, followed by the production of moulds and casts as described in 5.20.1.4.2. It requires one extra item of footwear, which will be destroyed during the production of the plaster of Paris mould.

Stage 1: Coat with petroleum jelly or releasing agent the inside of an item of footwear the same size as that to be tested. Secure the fastening system and fill to the top of the opening with a mixture of plaster of Paris and water. Leave until set and then remove by cutting away the footwear. After removal, place in an oven at about 80 °C to dry.

Stage 2: Continue as for stage 1 in 5.20.1.4.2 using the plaster of Paris cast in the place of making last.

Continue as for stage 2 in 5.20.1.4.2."

5.21.3

Replace the text of 5.21.3 by:

"The following results shall be reported:

- see 4.4;
- if the ankle protection fully covers the minimum protection area (yes/no).

The determination of measurement uncertainty is not applicable."

5.22.3

Replace the 3rd paragraph by:

"A sample shall be taken from each of three items of footwear (small, medium and large sizes) to enable impact tests to be performed on outer protectors.

If inner ankle protection is claimed, a further sample shall also be taken from each of three items of footwear (small, medium and large sizes) to enable impact tests to be performed on inner protectors."

5.22.4.2

Replace the text of 5.22.4.2 by:

"The strike point shall be within the zone of protection marked on the specimen and not less than 10 mm from the edge.

The test piece is positioned outer surface upwards on the anvil in such a way that a part of the test area covers the centre point of the anvil. The test piece may be fixed in the selected position by covering with a suitably thin net or fabric with a centre hole of 20 mm to 25 mm diameter to avoid influencing the result. This auxiliary device should be pulled down, by means of elastic straps, with an overall force of 5 N to 10 N, which can easily be controlled by the force measuring system itself.

The drop striker is then released. The transmitted force, as well as damage or breakage of the test piece, is recorded.

The test piece shall be tested once only at each point.

For outer side protection, the test result is the average of the 3 measurements and the highest transmitted force.

If inner ankle protection has been tested, the results shall be reported independently and in the same way as outer protection."

6.2.3.1

Replace 6.2.3.1 by:

"6.2.3.1 Sampling

Use only one complete item of footwear of medium size as the test piece."

6.2.3.2

Add a 7th hyphen in the second paragraph:

"Dismantle the footwear in order to be able to put the upper flat and exclude the area corresponding to

- upper material above the drawn line H_1 ,
- the toecap,
- the lacing system (eyelet support, hook attachment),
- collar,
- stiffener/counter,
- contact with the upper/sole bounding.
- the tongue"

6.5.2.2.1.2

Replace the 3rd paragraph by:

"The cam which actuates the reciprocating part shall be driven by a constant-speed motor to give (370 ± 30) flexes per min, and with sufficient power to flex at least six and preferably twelve test pieces at one time."

6.5.3

Replace the text of 6.5.3 by:

"The following results shall be reported:

- see 4.4;
- upper flexing resistance (see 6.5.2.2).

The determination of measurement uncertainty is not applicable."

6.6.4

Replace the 3rd paragraph by:

"The test pieces are tested according to ISO 14268:2012, with a pre-test of (60 ± 5) min (see ISO 14268:2012, 6.6) and a testing time of (450 ± 30) min (see ISO 14268:2012, 6.9) without the changing of the silica gel."

6.10.3

Replace the text of 6.10.3 by:

"The following results shall be reported:

- see 4.4;
- hydrolysis of upper material.

The determination of measurement uncertainty is not applicable."

6.12.4.3

Replace the 1st line in the 2nd paragraph by:

"Membranes lining: the outer layer (in contact with the foot) develops a hole."

6.12.5

Replace the text of 6.12.5 by:

"The following results shall be reported:

- see 4.4;
- abrasion resistance for each sample.

The determination of measurement uncertainty is not applicable."

7.3.2.3

The full paragraph shall be deleted.

7.3.4.1.1

Replace the 1st paragraph by:

"Measure the initial thickness, e_p , of the insole according to 5.4.1.4."

7.3.4.3

Replace the 1st paragraph and Formula (10) by:

"Cut through the abraded area. Measure the minimum thickness in the abraded area, e_f , according to 5.4.1.4 and calculate the variation of thickness in % V_e , as given by Formula (10):

$$V_e = 100 - \frac{(e_i - e_f) \times 100}{e_i} \quad (10)"$$

8.4.3

Replace the text of 8.4.3 by:

"The following results shall be reported:

- see 4.4;
- the outsole abrasion resistance.

The determination of measurement uncertainty is not applicable."

8.9.1.1

Replace the text of the last sentence of the paragraph by:

"The other dimensions of the bit shall be as shown in Figure 47."

8.9.4

Replace the text of 8.9.4 by:

"The following results shall be reported:

- see 4.4;
- any degradation of the outsoles.

The determination of measurement uncertainty is not applicable."

Bibliography

Replace Reference [8] by the following:

"[8] ISO 20349-2:2017 + Amd 1:2020, *Personal protective equipment — Footwear protecting against risks in foundries and welding — Part 2: Requirements and test methods for protection against risks in welding and allied processes.*"

Bureau of Indian Standards

BIS is a statutory institution established under the *Bureau of Indian Standards Act, 2016* to promote harmonious development of the activities of standardization, marking and quality certification of goods and attending to connected matters in the country.

Copyright

BIS has the copyright of all its publications. No part of these publications may be reproduced in any form without the prior permission in writing of BIS. This does not preclude the free use, in the course of implementing the standard, of necessary details, such as symbols and sizes, type or grade designations. Enquiries relating to copyright be addressed to the Head (Publication & Sales), BIS.

Review of Indian Standards

Amendments are issued to standards as the need arises on the basis of comments. Standards are also reviewed periodically; a standard along with amendments is reaffirmed when such review indicates that no changes are needed; if the review indicates that changes are needed, it is taken up for revision. Users of Indian Standards should ascertain that they are in possession of the latest amendments or edition by referring to the website-www.bis.gov.in or www.standardsbis.in.

This Indian Standard has been developed from Doc No.: CHD 19 (19020).

Amendments Issued Since Publication

Amend No.	Date of Issue	Text Affected

BUREAU OF INDIAN STANDARDS

Headquarters:

Manak Bhavan, 9 Bahadur Shah Zafar Marg, New Delhi 110002

Telephones: 2323 0131, 2323 3375, 2323 9402

Website: www.bis.gov.in

Regional Offices:

Central : 601/A, Konnectus Tower -1, 6th Floor,
DMRC Building, Bhavbhuti Marg, New
Delhi 110002

Telephones

{ 2323 7617

Eastern : 8th Floor, Plot No 7/7 & 7/8, CP Block, Sector V,
Salt Lake, Kolkata, West Bengal 700091

{ 2367 0012
2320 9474

Northern : Plot No. 4-A, Sector 27-B, Madhya Marg,
Chandigarh 160019

{ 265 9930

Southern : C.I.T. Campus, IV Cross Road, Taramani, Chennai 600113

{ 2254 1442
2254 1216

Western : Manakalya, 5th Floor/MTNL CETTM, Technology Street, Hiranandani Gardens, Powai
Mumbai 400076

{ 25700030
25702715

Branches : AHMEDABAD, BENGALURU, BHOPAL, BHUBANESHWAR, CHANDIGARH, CHENNAI, COIMBATORE, DEHRADUN, DELHI, FARIDABAD, GHAZIABAD, GUWAHATI, HARYANA (CHANDIGARH), HUBLI, HYDERABAD, JAIPUR, JAMMU, JAMSHEDPUR, KOCHI, KOLKATA, LUCKNOW, MADURAI, MUMBAI, NAGPUR, NOIDA, PARWANOO, PATNA, PUNE, RAIPUR, RAJKOT, SURAT, VIJAYAWADA.