

घरेलू प्रयोजनों के लिए ज़िग-ज़ैग सिलाई
मशीन/हेड

भाग 2 परिशुद्धता अपेक्षाएँ

(पहला पुनरीक्षण)

Household Zig-Zag Sewing
Machine/Head

Part 2 Accuracy Requirements

(First Revision)

ICS 61.080

© BIS 2024



भारतीय मानक ब्यूरो
BUREAU OF INDIAN STANDARDS
मानक भवन, 9 बहादुर शाह ज़फर मार्ग, नई दिल्ली - 110002
MANAK BHAVAN, 9 BAHADUR SHAH ZAFAR MARG
NEW DELHI - 110002

www.bis.gov.in www.standardsbis.in

FOREWORD

This Indian Standard (Part 2) (First Revision) was adopted by the Bureau of Indian Standards, after the draft finalized by the Sewing Machine Sectional Committee had been approved by the Mechanical Engineering Division Council.

This standard was first published in 2004. This standard is being revised to keep pace with the latest technological developments and international practices. Also, in this revision, the standard has been brought into the latest style and format of Indian Standards. The following major modifications have been incorporated in this revision of the standard:

- a) Title has been changed;
- b) Scope has been amended to include electronically controlled zig-zag operation;
- c) Functional dimensions has been updated and another note has been added to cover the rotary hook mechanism (full rotation) machines in [2.1](#);
- d) Assembly clearance has been amended to include accuracy requirements for rotary hook mechanism in [2.2](#);
- e) [Figure 3](#) in [Annex A](#) for needle and shuttle has been updated; and
- f) Relevant changes have been made in [Annex A](#).

This standard has been formulated to facilitate standardization and with a view to establish quality and accuracy requirements of household zig-zag sewing machine/head, which includes machines with mechanical/electronically operated zig-zag operations.

In the preparation of this standard, assistance has been derived from IS 7491 : 1989 'Sewing machine, household — Accuracy requirements (*first revision*)'.

The standard on household zig-zag sewing machine, which includes machines with mechanical/electronically operated zig-zag operations, is being brought in four parts, the other parts in the series are:

- Part 1 General requirements
- Part 3 Sewing requirements
- Part 4 Durability requirements

This standard covers all types of zig-zag sewing machine/head, excluding embroidery sewing machines.

The composition of the Committee responsible for the formulation of this standard is given in [Annex B](#).

For the purpose of deciding whether a particular requirement of this standard is complied with, the final value, observed or calculated, expressing the result of a test or analysis, shall be rounded off in accordance with IS 2 : 2022 'Rules for rounding off numerical values (*second revision*)'. The number of significant places retained in the rounded off value should be the same as that of the specified value in this standard.

*Indian Standard***HOUSEHOLD ZIG-ZAG SEWING MACHINE/HEAD****PART 2 ACCURACY REQUIREMENTS***(First Revision)***1 SCOPE**

This standard (Part 2) covers the accuracy requirements for household zig-zag sewing machine/head, which includes machines with mechanical/electronically operated zig-zag operations.

NOTE — This standard covers all types of zig-zag sewing machine/head, excluding embroidery sewing machines.

2 ACCURACY REQUIREMENT**2.1 Functional Dimensions**

Clearance and heights at various points on the machine shall be as follows:

<i>Sl No.</i>	<i>Item</i>	<i>Measuring Condition</i>	<i>Measuring Direction</i>	<i>Ref to Figure</i>	<i>Standard Assembly Dimension mm</i>
(1)	(2)	(3)	(4)	(5)	(6)
i)	Feed dog	Height of the feed dog teeth above needle/throat plate	Feed dog raised to its highest position	1	1.2, <i>Max</i>
ii)	Shuttle and shuttle driver ¹⁾	Clearance between heel of shuttle and corresponding tip of shuttle driver	Shuttle heel at bottom most position	2	0.25, <i>Min</i> 0.55, <i>Max</i>
iii)	Needle and shuttle for oscillation mechanism	Clearance between needle and corresponding face of shuttle	Needle at bottom most position	3	0, <i>Min</i> 0.05, <i>Max</i>
	Needle and shuttle for rotary hook	Clearance between needle and corresponding face of shuttle	Needle at bottom most position		0, <i>Min</i> 0.10 <i>Max</i>
iv)	Presser foot	Gap between pressure foot and needle/throat plate	Presser foot in lifted condition	4	5.0, <i>Min</i>
v)	Width (zig-zag)	Distance between two extreme needle positions when needle vibration adjustment is at its maximum	Zig-zag width knob or control at its maximum position	5A 5B	5.0 ¹⁾ , <i>Min</i>
vi)	Disc follower ¹⁾	Clearance between disc follower pin and the highest point of disc no. 1	Needle bar at its bottom most position	6	0.25, <i>Max</i>

NOTES

1 For sewing machines with rotary hook mechanism (full rotation – top loaded or front loaded) in place of oscillating shuttle mechanism requirements under SI No. (ii) shall not be applicable.

2 SI No. (vi) shall not be applicable for sewing machine with electronically controlled zig-zag operations.

¹⁾Optional requirements depending upon the design specifications of the sewing machine.

IS 15449 (Part 2) : 2024

2.2 Assembly Clearance

The assembly clearances on the machine at various points shall meet the following requirements:

<i>Sl No.</i>	<i>Item</i>	<i>Measuring Condition</i>	<i>Measuring Direction</i>	<i>Indicator Position</i>	<i>Ref to Figure</i>	<i>Maximum Assembly Clearance mm</i>
(1)	(2)	(3)	(4)	(5)	(6)	(7)
i)	Needle bar	Needle bar at lower most position	a) In the direction of motion	a) Top of needle bar	7A	0.35
			b) At right angle to the direction of motion	b) Near the bottom of needle bar	7B	0.20
ii)	Thread take-up lever	Thread take-up lever at top, intermediate and bottom positions	a) In the direction of motion	a) Around thread hole	8A	0.65
			b) At right angle to the direction of motion	b) Around thread hole	8B	0.75
iii)	Shuttle	a) Tip of shuttle pin at top most/bottom most position of needle bar b) Difference between two indicator readings when needle bar is at its highest and lowest position	a) Along the axis of shuttle pin	a) Tip of shuttle pin	9	0.20
			b) Along the axis of shuttle pin	b) Tip of shuttle pin		0.08
	For rotary hook mechanism	With bobbin-case removed, play of bobbin case holder	a) In and out	a) On the center pin	9	0.07
			b) Up and down	b) Top of the holder		0.16
iv)	Arm shaft	At different arm shaft positions (turn wheel by hand). Axial push/pull to be given:	Axial direction	Face of rim of wheel:	10	0.10

<i>Sl No.</i>	<i>Item</i>	<i>Measuring Condition</i>	<i>Measuring Direction</i>	<i>Indicator Position</i>	<i>Ref to Figure</i>	<i>Maximum Assembly Clearance mm</i>
(1)	(2)	(3)	(4)	(5)	(6)	(7)
v)	Wheel	a) Rotate arm shaft to measure wobbling	Axial direction	a) Face of rim of wheel	11A	0.25
		b) Rotate arm shaft to measure eccentricity	Radial direction	b) Any point on the periphery of rim of wheel	11B	0.30
vi)	Feed section	At the highest position of feed dog above needle plate	In the direction of motion	Front edge of the feed dog	12	0.35

NOTE — The product and figures on measurement methods are for reference purpose only and may vary across different models and manufacturers.

3 METHOD OF TESTS

The method for carrying out various accuracy tests are given in [Annex A](#).

ANNEX A

([Foreword](#) and [Clause 3](#))

METHOD OF TESTS

A-1 FEED DOG HEIGHT

For measurement of feed dog height, the arm shaft shall be rotated so as to bring the feed dog to its highest position above the needle plate. The dial indicator shall be so set as to accommodate both the top of the feed dog as well as the needle plate surface within its range. At this position, two readings shall be taken, one at the top of feed dog and the other at the needle plate surface. The difference between these two observations shall indicate the maximum height of the feed dog above the needle plate (see [Fig. 1](#)).

A-2 SHUTTLES AND SHUTTLE DRIVER CLEARANCE

For measurement of the clearance, between shuttle and shuttle driver the machine shall be held in the inclined position. The arm shaft shall be rotated while observing the relative position of the shuttle and its driver till the shuttle heel comes to the bottom most position. At this stage, the measurement for clearance between the heel of the shuttle and the corresponding tip of the shuttle driver shall be made by using a feeler gauge. This clearance indicates the clearance existing between the shuttle and shuttle driver (see [Fig. 2](#)).

A-3 NEEDLE AND SHUTTLE

For measurement of the clearance, between needle and the corresponding face of shuttle, the machine shall be held in the inclined position. The arm shaft shall be rotated while observing the relative position of the needle and the corresponding face of shuttle, till needle comes to the bottom most position. At this stage, the measurement for clearance between the needle and the corresponding face of the shuttle shall be made by using a feeler gauge. This indicates the clearance existing between the needle and the corresponding face of shuttle (see [Fig. 3](#)).

A-4 PRESSER FOOT GAP

For measurement of the presser foot gap, the presser foot shall be lifted to its highest position. The gap between the bottom face of presser foot and the surface of needle plate shall be measured with a suitable gauge. This gap indicates the maximum clearance available between the presser foot and the

needle plate of a sewing machine (see [Fig. 4](#)).

A-5 ZIG-ZAG WIDTH

A-5.1 For measurement of the zig-zag width or the distance between two needle penetrations (in the needle plate) on the left and right sides respectively, the zig-zag width knob/on the display control panel shall be set at its maximum position. The feed regulator (FR) thumbscrew/display control panel shall be set at zero position or the feed throw out (FTO) knob shall be adjusted to feed drop position (see [Fig. 5A](#)).

A-5.2 The arm shaft shall be rotated to take the two penetrations on a piece of paper (instead of cloth), placed between the needle plate and presser foot. The paper shall be taken out from the machine and the distance between the two penetrations measured with the help of a scale. This measurement shall be the width of the zig-zag sewing machine (see [Fig. 5B](#)).

A-6 DISC FOLLOWER

For measurement of the clearance, between disc follower pin and the highest point of disc no. 1, rotate the section of panel upwards as shown in [Fig. 6](#). The arm shaft shall be rotated, while observing the relative position of the disc follower pin and the disc no. 1, till the needle bar comes to its bottom most/top most position. At this stage, the measurement for clearance shall be made by using a feeler gauge. This measurement shall indicate the clearance existing between the disc follower pin and the highest point of disc no. 1 (see [Fig. 6](#)).

A-7 NEEDLE BAR

A-7.1 With the zig-zag width knob/on the display control panel at straight stitch position, move the needle bar to its lowest position and place the dial indicator on the top of the needle bar using an extension piece, if necessary. Apply light hand pressure at the bottom of the needle bar to push it up and note the indicator reading. Similarly, pull the needle bar down with the same pressure and take the second indicator reading. The difference between the two readings shall indicate the assembly clearance for needle bar in the direction of motion (see [Fig. 7A](#)).

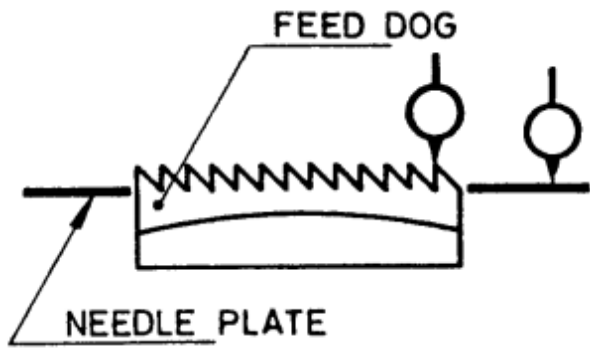

FIG. 1 FEED DOG HEIGHT

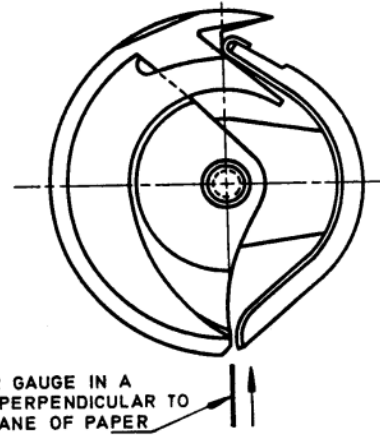

FIG. 2 SHUTTLES AND SHUTTLE DRIVER CLEARANCE

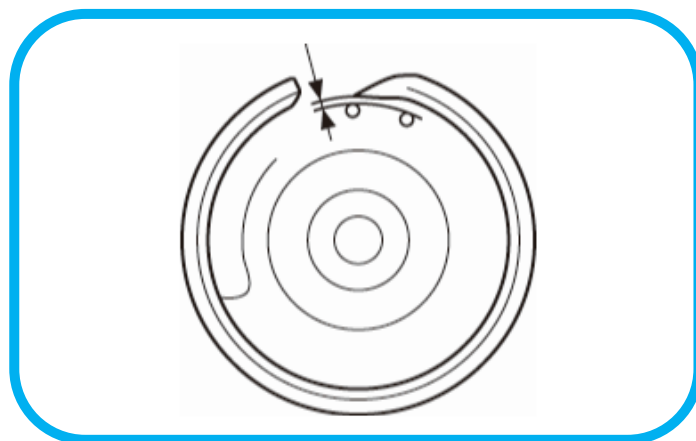
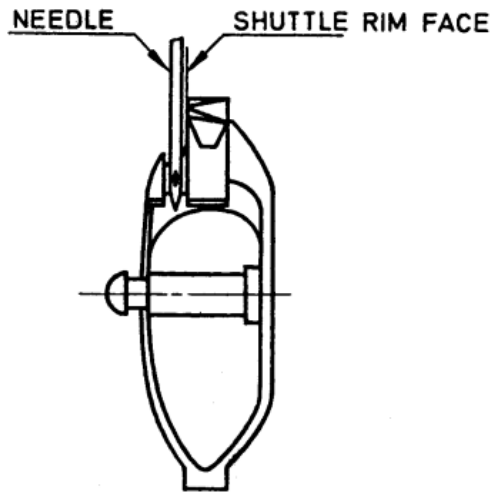

FIG. 3 FULL ROTARY NEEDLE AND SHUTTLE CLEARANCE

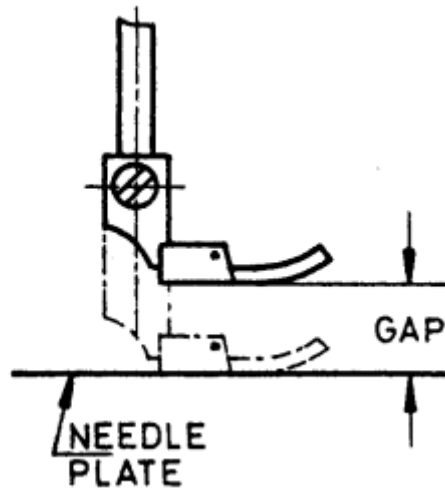

FIG. 4 PRESSURE FOOT GAP

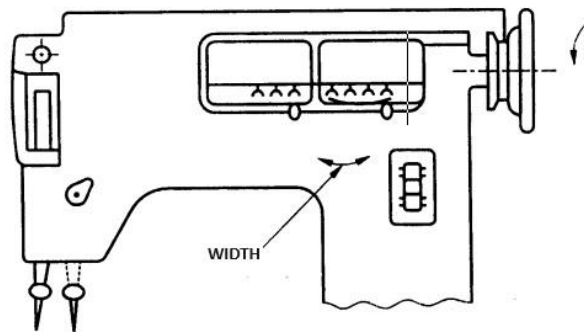

FIG. 5A ZIG-ZAG WIDTH

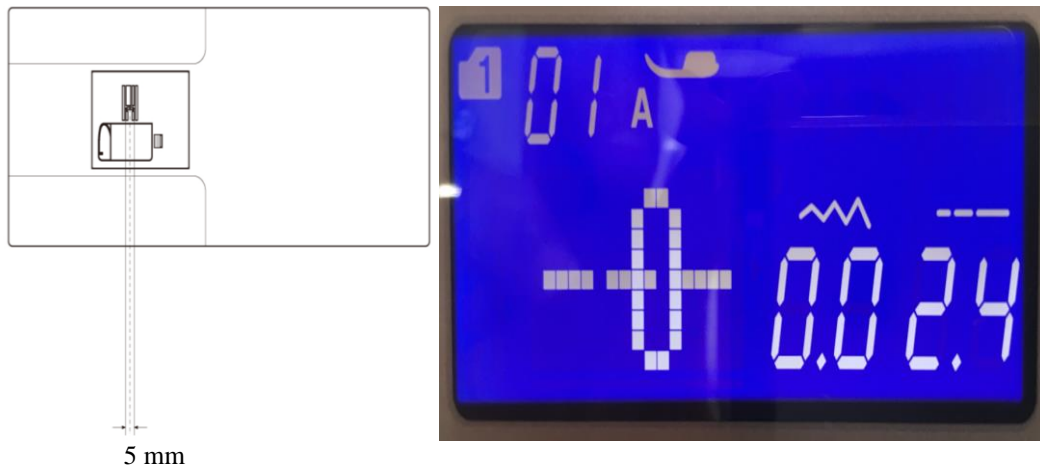
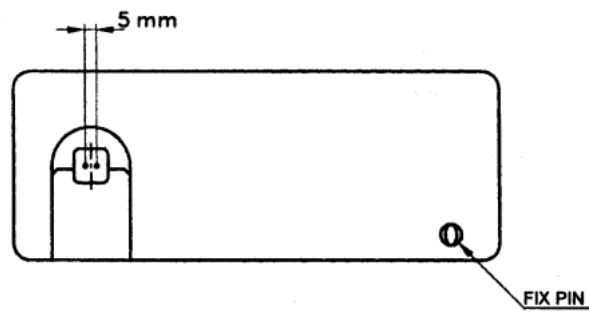

FIG. 5B ZIG-ZAG WIDTH

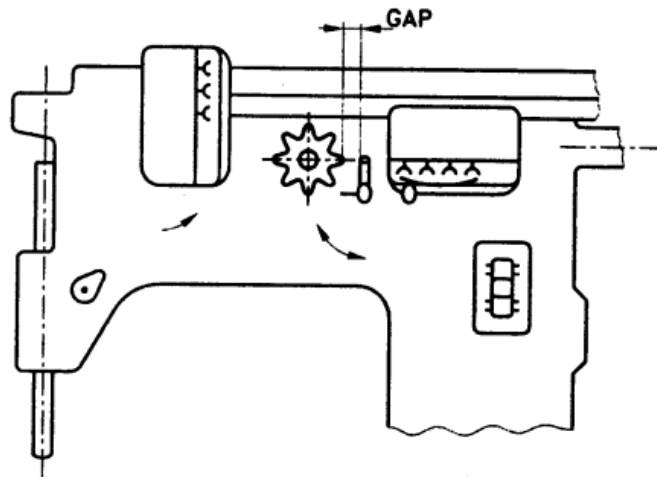

FIG. 6 DISC FOLLOWER

A-7.2 With the needle bar to its lowest position and zig-zag width knob/on the display control panel at straight stitch position places the indicator near its lower tip by the side of the needle bar. Apply sideward light hand pressure forward and backward. Take one reading of the indicator at each of these two positions. The difference between the two readings shall indicate the assembly clearance for needle bar in the direction of right angle to that of the motion (see [Fig. 7B](#)).

A-8 THREAD TAKE UP LEVER

A-8.1 Bring the thread take up lever at its top/intermediate/bottom position. Place the indicator above the lever around the thread hole. Pull the lever down with very light hand pressure and note the indicator reading. Similarly, push the lever up with the same pressure and observe the second reading. The difference between the two readings will indicate the clearance in the direction of motion for thread take up lever at its given position (see [Fig. 8A](#)).

A-8.2 For the clearance in the right angle direction, place the indicator on the sidewall near the thread hole of the take up lever. Apply very light pressure on the tip of the lever forward and backward and take one reading of the indicator at each of these two positions. The difference between the two readings shall indicate the assembly clearance for thread take up lever in the direction of right angle to that of the motion (see [Fig. 8B](#)).

A-9 SHUTTLE

Set the indicator on the top of shuttle pin in the axial direction. Hold the pin and apply very light axial pull and push and take one reading of the indicator at each of these two positions. The difference between the two readings indicates the assembly clearance for the shuttle in the axial direction. An

indicator attachment may be necessary for this measurement (see [Fig. 9](#)).

A-10 ARM SHAFT

Place the indicator in contact with the side face of the rim of arm shaft at any convenient point. Apply medium hand pressure and pull and push the arm shaft in the axial direction of the arm shaft. Take one reading of the indicator at each of these two positions. The difference between the two readings shall indicate the clearance for the arm shaft in the axial direction (see [Fig. 10](#)).

A-11 WHEEL

A-11.1 For determination of the wobbling of the arm shaft, bring the indicator in contact with the side face of the rim of the wheel. Rotate the wheel by at least one revolution and note the total difference in indicator reading. This reading will indicate the wobbling of the arm shaft in the axial direction (see [Fig. 11A](#)).

A-11.2 For determination of the eccentricity of the arm shaft, bring the indicator in contact with the circumference of the wheel. Rotate the arm shaft by at least one revolution and note the total difference in indicator reading. This reading will indicate the eccentricity of the arm shaft in the radial direction (see [Fig. 11B](#)).

A-12 FEED DOG SECTION

For measurement of the feed dog section, the arm shaft shall be rotated so as to bring the feed dog to its highest position above the needle plate. The dial indicator shall be set on the front edge of the feed dog. The maximum feed amount shall be measured with dial indicator in the direction of motion (see [Fig. 12](#)).

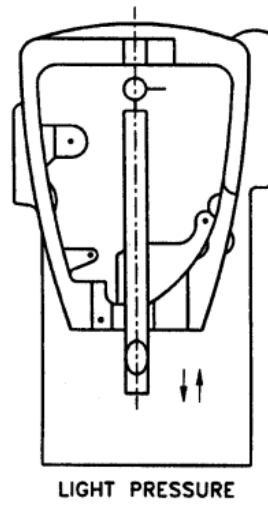

FIG. 7A ASSEMBLY CLEARANCE FOR NEEDLE BAR IN THE DIRECTION OF MOTION

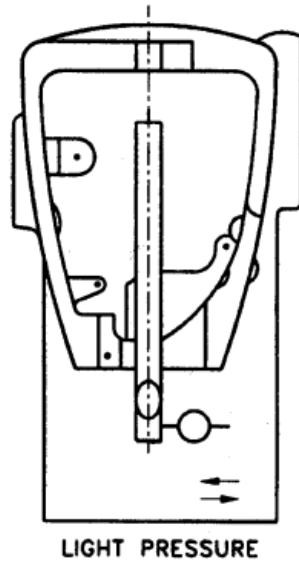

FIG. 7B ASSEMBLY CLEARANCE FOR NEEDLE BAR IN THE DIRECTION OF RIGHT ANGLE TO THE MOTION

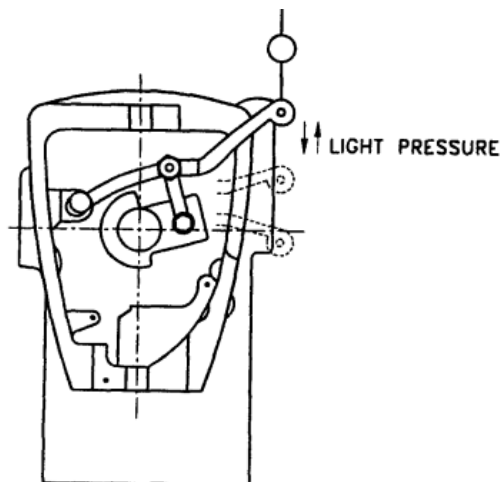

FIG. 8A THREAD TAKE UP LEVER

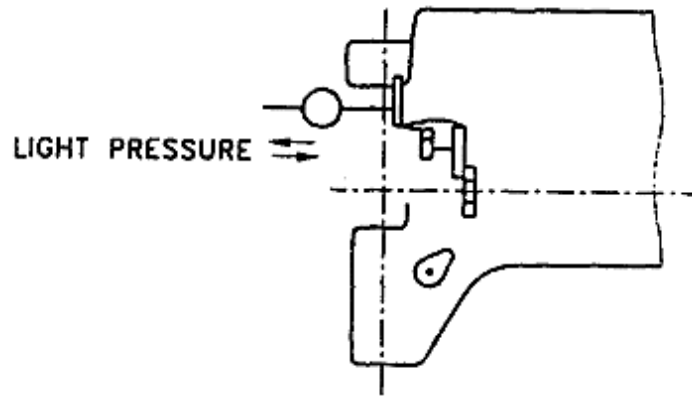

FIG. 8B THREAD TAKE UP LEVER (RIGHT ANGLE)

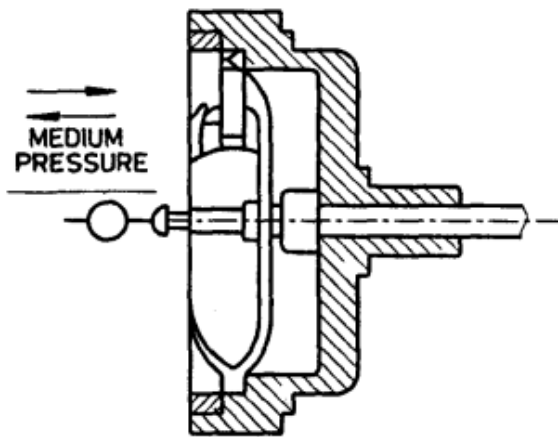

FIG. 9 SHUTTLE

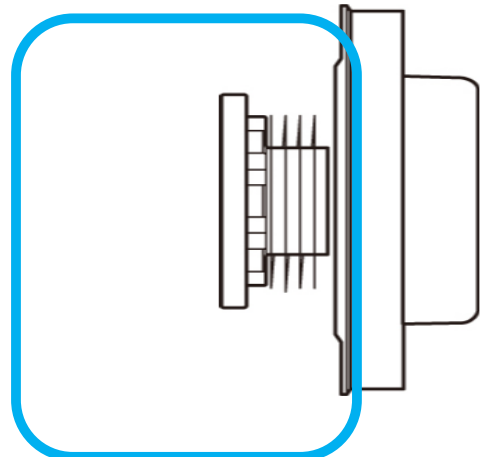

FIG. 10 ARM SHAFT CLEARANCE

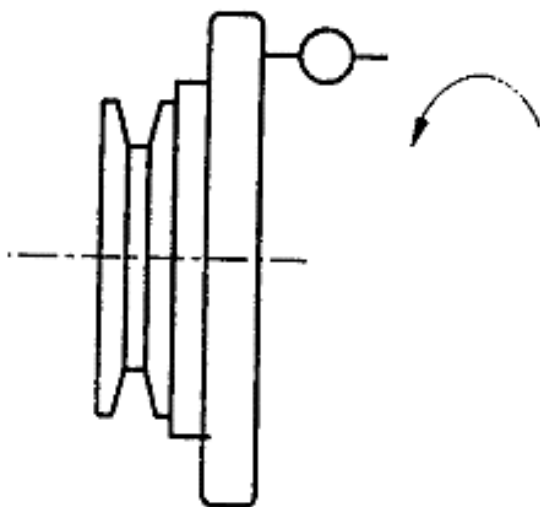

FIG. 11A ARM SHAFT (WOBBLING)

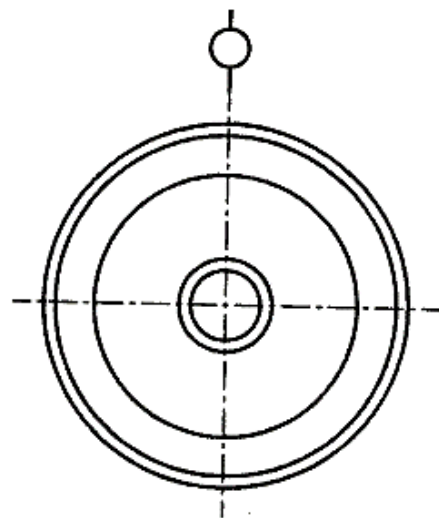

FIG. 11B ARM SHAFT (ECCENTRICITY)

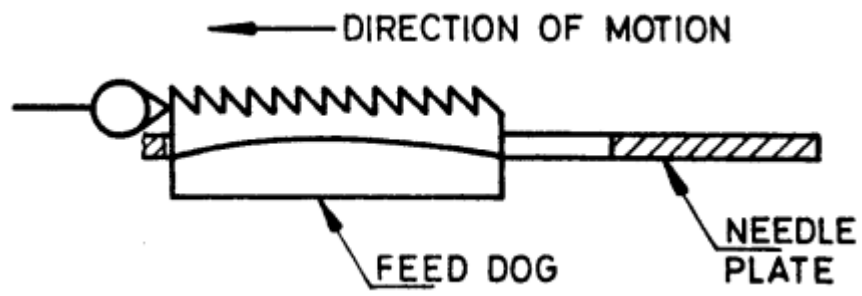

FIG. 12 FEED DOG SECTION

ANNEX B

(Foreword)

COMMITTEE COMPOSITION

Sewing Machines Sectional Committee, MED 29

<i>Organization</i>	<i>Representative (s)</i>
Research & Development Centre for Bicycle and Sewing Machines, Ludhiana	SHRI SANJEEV KATOCH (Chairperson) SHRI PAPINDER SINGH (<i>Alternate I</i>) SHRI VISHWAS MEHTA (<i>Alternate II</i>) SHRI MANPREET SINGH (<i>Alternate III</i>)
Brother International (India) Private Limited, Mumbai	SHRI MATHEW YOHANNAN
C.R. Auluck & Sons Private Limited, Ludhiana	SHRI SUNIL AULUCK SHRI KULJEET SINGH (<i>Alternate</i>)
Directorate General of Quality Assurance, New Delhi	SHRI R. V. JAIN
G.D. Rupal Industries, Ludhiana	SHRI GURMUKH SINGH
Gee Tech Hooks, Ludhiana	SHRI MANJEET SINGH
Geminy Industrial Enterprises Private Limited, Ludhiana	SHRI VINAY DUA SHRI B. C. PANDEY (<i>Alternate</i>)
Ludhiana Sewing Machine Association, Ludhiana	SHRI HARDEEP SINGH SHRI RAJVINDER (<i>Alternate</i>)
Makhan Sewing Machines, Ludhiana	SHRI DALBIR SINGH DHIMAN
Mechanical Engineering Research and Development Organization (MERADO), Ludhiana	SHRI SYED SALMAN MOJIZ SHRI BHAGWANT SINGH LAL (<i>Alternate</i>)
Narindera and Company, Ludhiana	SHRI S. BALDEV SINGH SHRI HARINDER JIT SINGH (<i>Alternate</i>)
Navrang Manufacturing Corporation, Ludhiana	SHRI DINESH KAPILA SHRI SUDESH KAPILA (<i>Alternate</i>)
Northern India Textile Research Association, Ghaziabad	SHRI VIKAS SHARMA SHRI VIVEK AGARWAL (<i>Alternate</i>)
Novel Sewing Machine Technologies, Pune	SHRI BHARAT NARAYENDAS PARMAR SHRI ARJUN BHARAT PARMAR (<i>Alternate</i>)
ORAA International, Ludhiana	SHRI ASHISH GUPTA
Office of Development Commissioner (MSME), New Delhi	SHRI SUVANKAR SANTRA MS MAITREYEE TALAPATRA (<i>Alternate</i>)
Ranew Engineering (India) Private Limited, Ludhiana	SHRI SANJEEV KUMAR JAIN SHRI ABHILASH JAIN (<i>Alternate</i>)
Rita Machines India Private Limited, Ludhiana	SHRI SUNIL KUMAR JAIN SHRI JAGDISH CHANDRA AULUCK (<i>Alternate</i>)
Singer India Limited, New Delhi	SHRI PRASHANT AGGARWAL SHRI ATUL KUMAR SETH (<i>Alternate</i>)
Swan Mechanical Works, Ludhiana	SHRI AMARJEET SINGH

IS 15449 (Part 2) : 2024

<i>Organization</i>	<i>Representative (s)</i>
United Sewing Machines and Parts Manufacturing Association, Ludhiana	SHRI DALBIR SINGH DHIMAN
Usha International Limited, New Delhi	SHRI RUP LAL KANGLA SHRI PRANAY SRIWASTAV (<i>Alternate</i>)
Uttam Sewing Machine Company (Private) Limited, Jalandhar	SHRI JAGDEEP RAI SHRI MANOHAR LAL (<i>Alternate</i>)
Virindra Engineering Works, Ludhiana	SHRI AMARPREET SINGH PANESAR SHRI SWARN SINGH (<i>Alternate</i>)
Voluntary Organisation in Interest of Consumer Education (VOICE), New Delhi	SHRI M. A. U. KHAN
BIS Directorate General	SHRI K. VENKATESWARA RAO, SCIENTIST 'F'/SENIOR DIRECTOR AND HEAD (MECHANICAL) [REPRESENTING DIRECTOR GENERAL (<i>Ex-officio</i>)]

Member Secretary
SHRI SHUBHAM TIWARI
SCIENTIST 'D'/JOINT DIRECTOR
(MECHANICAL), BIS

Bureau of Indian Standards

BIS is a statutory institution established under the *Bureau of Indian Standards Act, 2016* to promote harmonious development of the activities of standardization, marking and quality certification of goods and attending to connected matters in the country.

Copyright

BIS has the copyright of all its publications. No part of these publications may be reproduced in any form without the prior permission in writing of BIS. This does not preclude the free use, in the course of implementing the standard, of necessary details, such as symbols and sizes, type or grade designations. Enquiries relating to copyright be addressed to the Head (Publication & Sales), BIS.

Review of Indian Standards

Amendments are issued to standards as the need arises on the basis of comments. Standards are also reviewed periodically; a standard along with amendments is reaffirmed when such review indicates that no changes are needed; if the review indicates that changes are needed, it is taken up for revision. Users of Indian Standards should ascertain that they are in possession of the latest amendments or edition by referring to the website-www.bis.gov.in or www.standardsbis.in.

This Indian Standard has been developed from Doc No.: MED 29 (25848).

Amendments Issued Since Publication

Amend No.	Date of Issue	Text Affected

BUREAU OF INDIAN STANDARDS

Headquarters:

Manak Bhavan, 9 Bahadur Shah Zafar Marg, New Delhi 110002

Telephones: 2323 0131, 2323 3375, 2323 9402

Website: www.bis.gov.in

Regional Offices:

Central : 601/A, Konnectus Tower -1, 6th Floor,
DMRC Building, Bhavbhuti Marg, New
Delhi 110002

Telephones

{ 2323 7617

Eastern : 8th Floor, Plot No 7/7 & 7/8, CP Block, Sector V,
Salt Lake, Kolkata, West Bengal 700091

{ 2367 0012
2320 9474

Northern : Plot No. 4-A, Sector 27-B, Madhya Marg,
Chandigarh 160019

{ 265 9930

Southern : C.I.T. Campus, IV Cross Road, Taramani, Chennai 600113

{ 2254 1442
2254 1216

Western : 5th Floor/MTNL CETTM, Technology Street, Hiranandani Gardens, Powai
Mumbai 400076

{ 25700030
25702715

Branches : AHMEDABAD, BENGALURU, BHOPAL, BHUBANESHWAR, CHANDIGARH, CHENNAI, COIMBATORE, DEHRADUN, DELHI, FARIDABAD, GHAZIABAD, GUWAHATI, HARYANA (CHANDIGARH), HUBLI, HYDERABAD, JAIPUR, JAMMU, JAMSHEDPUR, KOCHI, KOLKATA, LUCKNOW, MADURAI, MUMBAI, NAGPUR, NOIDA, PARWANOO, PATNA, PUNE, RAIPUR, RAJKOT, SURAT, VIJAYAWADA.