रंग रोगन, प्लास्टिक इमल्शन — विशिष्टि
(दूसरा पुनरीक्षण)

**Paint, Plastic Emulsion —
Specification**
(*Second Revision*)

ICS 87.040

© BIS 2024



भारतीय मानक ब्यूरो
BUREAU OF INDIAN STANDARDS
मानक भवन, 9 बहादुर शाह ज़फर मार्ग, नई दिल्ली - 110002
MANAK BHAVAN, 9 BAHADUR SHAH ZAFAR MARG
NEW DELHI - 110002

www.bis.gov.in www.standardsbis.in

FOREWORD

This Indian Standard (Second Revision) was adopted by the Bureau of Indian Standards, after the draft finalized by the Paints, Varnishes and Related Products Sectional Committee had been approved by the Chemical Division Council.

The use of the plastic emulsion paints has been on the increase over the last few years. These paints have gained popularity because of their ease of application, quick drying properties, non-objectionable odour and good washability. In view of the growing demand for this material, this standard was formulated to enable manufacturers to maintain the quality and assist the consumers in selecting material of an acceptable performance.

This standard was first published in two parts as IS 5411 (Part 1) 'Plastic emulsion paint: Part 1 For interior use' and IS 5411 (Part 2) 'Plastic emulsion paint: Part 2 For exterior use'. However, while revising those standards, the Committee felt that it would be more convenient for users to have a single standard, incorporating two types of plastic emulsion paints and published IS 15489 superseding IS 5411 (Part 1) and IS 5411 (Part 2). Different types of finishes were also incorporated to bring it at par with existing practices. Accordingly, requirement of drying time, for both surface and hard dry, were modified with regard to the type of finishes. Other optional requirements like spreading capacity, hiding power and spreading time were also deleted; while gloss value, at 60° for various classes were included.

The first revision of this standard in 2013, was taken up with a view to incorporate the limit of lead restriction. The technical committee responsible for formulation of this standard observed that in practice most of the paints like this paint are used for household/decorative as well as in industrial/commercial applications. Taking cognizance of the fact that exposure of human being to lead, particularly children in residential premises is injurious to health and having adverse impact on human health and safety, the Committee had felt the need to introduce lead restriction in all paints standards likely to be used for household and decorative purposes.

This product is extensively used for interior and exterior decoration of building surfaces to other applications. The Committee had observed that due to the vary nature of constituents used in formulation of this product, it may not be feasible to manufacture this product having lead restriction very low. Therefore, lead restriction up to a maximum permissible limit of 300 ppm had prescribed to avoid hazardous impact of lead exposure in homes and consequent adverse impact on environment and human health. Further, majority of consumers are not aware of the consequences of lead toxicity and its long-term implications to human health. Therefore, along with lead restriction, a suitable cautionary notice was included in the marking clause.

Durability test as given in [6.8](#) had modified as 'Durability test for exterior use only' to differentiate between the performance for interior use and exterior use. The 'temperature stability test' had renamed as 'accelerated storage stability test'.

A scheme for labelling environment friendly products to be known as ECO-Mark is already there at the instance of the Ministry of Environment and Forests (MoEF). The ECO-Mark shall be administered by the Bureau of Indian Standards (BIS) under the *Bureau of Indian Standards Act, 1986* as per the Resolution No. 71 dated 20 February 1991 published in the Gazette of the Government of India. For a product to be eligible for ECO-Mark it shall also carry Standard Mark of BIS for quality besides meeting additional optional environment friendly (EF) requirements.

(Continued on third cover)

*Indian Standard***PAINT, PLASTIC EMULSION — SPECIFICATION***(Second Revision)***1 SCOPE**

This standard prescribes the requirements and methods of sampling and test for plastic emulsion paint used for interior and exterior protection and decoration of building surfaces after surface preparation and priming.

2 REFERENCES

The standards listed in [Annex A](#) contain provisions, which through reference in this text, constitute provisions of this standard. At the time of publication, the editions indicated were valid. All standards are subject to revision and parties to agreements based on this standard are encouraged to investigate the possibility of applying the most recent edition of these standards.

3 TERMINOLOGY

For the purpose of this standard the definitions given in IS 1303 and the following shall apply.

3.1 Volatile Organic Compounds (VOC) — Is any organic compound having an initial boiling point less than or equal to 250 °C measured at a standard atmospheric pressure of 101.3 kPa.

3.2 Matt Finish — Having gloss values from 0 to 5, when viewed at 60°.

3.3 Egg Shell/Satin Finish — Having gloss values from 5 to 25 when viewed at 60°.

3.4 Semi-glossy Finish — Having gloss values from 26 to 69, when viewed at 60°.

3.5 Glossy Finish — Having gloss values 70 and above, when viewed at 60°.

4 TYPES

Plastic emulsion paint shall be of two types:

- a) *Type 1* — For interior use; and
- b) *Type 2* — For exterior use.

5 CLASS

There shall be following four classes of products:

- a) Class A — Matt finish;

- b) Class B — Egg shell/ satin finish;
- c) Class C — Semi-glossy finish; and
- d) Class D — Glossy finish.

6 REQUIREMENTS**6.1 Composition**

The material shall consist of pigments and if required suitable extenders in appropriate proportion in a medium consisting of any stable synthetic polymer emulsion in water with other suitable ingredients as may be necessary to produce a material so as to satisfy the requirements of this standard.

6.2 Conditions in the Container

The material shall be free from odour of putrefaction. It shall be free from lumps, skins and the conditions of the material shall be such that settling, if any, may be easily incorporated on stirring.

6.3 Thinning

When suitably thinned with water, the material shall mix readily with minimum amount of foaming to a smooth and homogeneous state. The foaming, if any, shall dissipate rapidly.

6.4 Application Properties

The material after recommended thinning shall be suitable for application by brush, spray or roller. The resulting film shall not show pigment flocculation, coarseness or other undesirable characteristics.

6.5 Mass in kg/10 litres

The mass in kg/10 litres of the material, when tested as prescribed in IS 101 (Part 1/Sec 7), shall not differ by more than ± 3 percent from that of the approved sample.

6.6 Opacity**6.6.1 Panel**

Panel used for this test, unless otherwise mentioned, shall be prepared as prescribed in IS 101 (Part 1/Sec 3).

6.6.2 Procedure

Apply one coat of a primer paint conforming to IS 109 of off-white/grey shade on concrete panel [see IS 101 (Part 1/Sec 3)] size 100 mm × 150 mm and air dry. Again, apply two coats of paint (to be tested) on the panel and match with the specified colour after hard drying.

6.6.3 The material deemed to have passed the test if the colour of the painted panel closely match with the specified colour (see IS 5).

6.7 Fastness to Light

6.7.1 Panel

Unless otherwise mentioned, white unglazed art paper of sizes suitable to accommodate in the test apparatus, shall be used for this test. However, panel of concrete panel [see IS 101 (Part 1/Sec 3)] may be used for this test, if otherwise mentioned. This panel shall be prepared as prescribed in [IS 101 (Part 1/Sec 3)] and having dimensions, suitable for the apparatus being used for the test but shall not be smaller than 60 mm × 40 mm.

6.7.2 Test Conditions

The material shall be tested according to the method prescribed in [IS 101 (Part 4/Sec 3)] in xenon arc apparatus with the test conditions as prescribed below:

- a) black panel temperature (63 ± 3)°C;
- b) continuous exposure in light; and
- c) time of exposure to light for 500 h.

6.8 Durability Test for Exterior Use Only

6.8.1 Registered Sample

A film of the registered sample shall be prepared and tested in an accelerated weathering apparatus (see Annex C) for a period of 21 days; performance of the sample shall be examined and recorded every third day for the entire test period.

NOTES

1 As a precaution against inadvertent accidents, it is recommended that the accelerated weathering test (see Annex C) may be carried out in duplicate.

2 For details of method of tests with QUV apparatus follow IS 101 (Part 6/Sec 5).

6.8.2 Sample from Bulk Supply

A film of the material prepared from a representative sample from bulk as described in Annex C and tested in the accelerated weathering apparatus (see Annex C) shall be not materially different in performance as compared with the record of the

film of the registered sample, when examined every third day for a period of 21 days.

6.9 Lead Restriction

The material shall be tested for restriction from lead in accordance with ICP-OES or AAS method of IS 101 (Part 8/Sec 5). When thus tested the material shall not contain lead or compounds of lead or mixtures of both, calculated as metallic lead exceeding 90 ppm.

6.10 Keeping Properties

The material shall conform to all the requirements as prescribed in 6.2 to 6.9 and 6.11 (including requirements given in Table 1) when tested after one year from the date of manufacturing. The material shall be stored in original sealed container under normal atmospheric condition.

6.11 The material shall also comply with the requirements given in Table 1.

6.12 Additional Optional Requirements for ECO-Mark

6.12.1 General Requirements

6.12.1.1 The product requirements for quality and performance prescribed under 6.1 to 6.11.

6.12.1.2 The manufacturer shall produce to BIS environmental consent clearance from the concerned state pollution control board as per the Provisions of Water (Prevention and Control of Pollution) Act, 1974 and Air Prevention and Control of Pollution Act, 1981 along with the authorization, if required under the Environment Protection Act, 1986 and rules made thereunder, while applying or ECO-Mark.

6.12.2 Specific Requirements

6.12.2.1 The product shall contain not more than 5 percent, by mass, volatile organic compounds, when tested according to the method prescribed in IS 101 (Part 2/Sec 3) and IS 101 (Part 2/Sec 4).

6.12.2.2 The product shall not contain more than 0.1 percent by mass (as metal), of any toxic metals such as lead, cadmium, chromium (VI) and their compounds when tested by the relevant atomic absorption spectrophotometric methods.

6.12.2.3 The product shall not be manufactured from any carcinogenic ingredients.

NOTE — The Central Drugs Research Institute and Industrial Toxicological Research Centre would furnish a list of carcinogenic ingredients to BIS and would also keep BIS informed about the changes therein.

Table 1 Requirements for Plastic Emulsion Paint(Clauses [6.10](#), [6.11](#), [9](#) and [D-4.1](#))

SI No.	Characteristic	Requirements	Methods of Test, Ref to
(1)	(2)	(3)	(4)
i)	Consistency	To pass the test	Annex B
ii)	Drying time, <i>Max</i>		Annex D
	a) Surface dry: Class A and B Class C and D	45 min 90 min	
	b) Hard dry: Class A and B Class C and D	4 h 8 h	
iii)	Finish	Smooth and uniform	Annex D
iv)	Gloss at 60°: a) Class A b) Class B c) Class C d) Class D	0 to 5 05 to 25 26 to 69 70 and above	IS 101 (Part 4/Sec 4)
v)	Colour	Close match to IS colour specified otherwise as agreed between the manufacturers and the users	Annex E
vi)	Fastness to light	Passes the test, if there shall be no appreciable colour change observed when compared to the unexposed panel	IS 101 (Part 4/Sec 3)
vii)	Resistance to alkali	To pass the test	Annex F
viii)	Washability and cleanability	To pass the test	Annex G
ix)	Accelerated storage stability	To pass the test	Annex H
x)	Recoating properties	To pass the test	Annex J
xi)	Volatile organic compound, gm/litre, <i>Max</i> (<i>see</i> notes): a) Class A b) Class B c) Class C d) Class D	50 100 150 200	IS 101 (Part 2/Sec 4) IS 101 (Part 2/Sec 3)
<p>NOTES</p> <p>1 It is In-can VOC as supplied by manufacturer, without including any thinner. Since the amount of thinner used on-site can vary depending on the application method (brushing, spraying, etc), it can be challenging to precisely track the extent of thinning during application.</p> <p>2 VOCs of colorant added at point-of-sale. The VOC content of product including the colorant added at the point-of-sale shall not exceed 50 grams per litre over and above the allowed VOC limit of product without colorant.</p> <p>3 For the calculation of the VOC content, for solvent and water-based paints, Method 2 and Method 3 may be employed respectively as given in the IS 101 (Part 2/Sec 3) or IS 101 (Part 2/Sec 4).</p>			

7 PACKING AND MARKING

7.1 Packing

Unless specified otherwise, the material shall be packed in suitable metal or plastic containers.

The ECO-Mark product shall be packed in such packages which shall be recyclable/reusable or biodegradable. It shall be accompanied with instructions for proper use so as to maximize product performance and minimize wastage.

NOTE — Subsequently the parameters evolved for packaging material/packages for ECO-Mark which are being separately notified/circulated, shall also apply.

7.2 Each container shall be marked with the following:

- a) Name of the material;
- b) Indication of the source of manufacture;
- c) Lead content (maximum);
- d) The maximum content of VOC in g/l of the product as supplied in container;
- e) Volume of the material;
- f) Batch number or lot number in code or otherwise;
- g) Month and year of manufacture;
- h) Colour/shade of the material; and
- j) A cautionary note as below:
 - 1) Keep out of reach of children;
 - 2) Dried film of this paint may be harmful if eaten or chewed; and
 - 3) This product may be harmful if swallowed or inhaled.

7.3 BIS Certification Marking

7.3.1 The product(s) conforming to the requirements of this standard may be certified as per

the conformity assessment schemes under the provisions of the *Bureau of Indian Standards Act, 2016* and the Rules and Regulations framed thereunder, and the products may be marked with the Standard Mark.

7.3.1.1 In case of products certified for ECO-Mark three major ingredients and hazardous chemicals shall be marked on the container.

7.3.1.2 The criteria for which the product has been labelled as ECO-Mark may also be marked on the container.

8 SAMPLING

8.1 Representative samples of the material shall be drawn as prescribed in IS 101(Part 1/Sec 1).

8.2 Criteria for Conformity

A lot shall be declared as conforming to the requirements of this standard if the test results of the composite samples satisfy the requirements as prescribed in [6.1](#) to [6.9](#) and [6.11](#).

9 TEST METHODS

9.1 Tests shall be conducted as prescribed in [6.1](#) to [6.10](#) and the test methods referred in col (4) of [Table 1](#).

9.2 Quality of Reagents

Unless specified otherwise, pure chemicals and distilled water (*see* IS 1070) shall be employed in tests.

NOTE — 'Pure chemicals' shall mean chemicals that do not contain impurities which affect the results of analysis.

ANNEX A

(Clause 2)

LIST OF REFERRED STANDARDS

IS No.	Title	IS No.	Title
IS 101	Methods of sampling and test for paints, varnish and related products:	(Sec 4) : 2020/ ISO 2813 : 2014	Gloss — Determination of gloss value at 20°, 60° and 85° (<i>fourth revision</i>)
(Part 1)	Test on liquid paints (general and physical),	(Part 6)	Durability tests,
(Sec 1) : 2023	Sampling (<i>third revision</i>)	(Sec 1) : 1988	Resistance to humidity under conditions of condensation (<i>third revision</i>)
(Sec 3) : 1986	Preparation of panels (<i>third revision</i>)	(Sec 2) : 1989	Keeping properties (<i>third revision</i>)
(Sec 7) : 2020/ ISO 2811-1 : 2016	Mass per 10 litres — Determination of density — Pycnometer method (<i>fourth revision</i>)	(Part 8/Sec 5) : 2022	Tests for pigments and other solids, Section 5 Lead restriction test (<i>fourth revision</i>)
(Part 2)	Test on liquid paints (chemical examination),	IS 109 : 2017	Specification for ready mixed paint, finishing, priming, plaster, to Indian Standard colour No. 361 light stone and No. 631 light grey, white and off-white (<i>second revision</i>)
(Sec 1) : 2018	Water content (<i>fourth revision</i>)	IS 285 : 2021	Laundry soaps — Specification (<i>fourth revision</i>)
(Sec 2) : 1986	Volatile matter (<i>third revision</i>)	IS 1070 : 2023	Reagent grade water (<i>fourth revision</i>)
(Sec 3) : 2015/ ISO 11890-1 : 2007	Determination of volatile organic compound (VOC) content — Difference method	IS 1303 : 1983	Glossary of terms relating to paints (<i>second revision</i>)
(Sec 4) : 2022/ ISO 11890-2 : 2020	Determination of volatile organic compound (VOC) and or semi volatile organic compounds (SVOC) content gas-chromatographic (<i>first revision</i>)	IS 1407 : 1980	Specification for round paint tins (<i>second revision</i>)
(Part 3/Sec 1) : 1986	Tests on paint film formation, Section 1 Drying time (<i>third revision</i>)	IS 2096 : 1982	Asbestos cement flat sheets — Specification (<i>first revision</i>)
(Part 4)	Optical tests,	IS 3574 (Part 2) : 2000	Organic pigments for paints — Specification: Part 2 Phthalocyanines (<i>first revision</i>)
(Sec 2) : 2021/ ISO 3668 : 2017	Colour-visual comparison of colour of paints (<i>fourth revision</i>)		
(Sec 3) : 1988	Light fastness test (<i>third revision</i>)		

To access Indian Standards click on the link below:

https://www.services.bis.gov.in/php/BIS_2.0/bisconnect/knowyourstandards/Indian_standards/isdetails/

ANNEX B

[Table 1, Sl No. (i)]

CONSISTENCY

B-1 APPARATUS

the original container and examine the nature of settling.

B-1.1 Palette Knife or Metal Rod**B-2.2 Observations****B-1.2 Panels**

Unless specified otherwise, concrete panel [see IS 101 (Part 1/Sec 3)] shall be taken for this test.

The material shall not cake hard inside the container and shall be in such a condition that stirring easily produces a smooth uniform paint suitable for brushing on panels.

B-2 PROCEDURE

B-2.1 Insert a clean metal rod or palette knife into

ANNEX C

(Clauses [6.8.1](#) and [6.8.2](#))

DETERMINATION OF DURABILITY

C-1 GENERAL

A concrete panel is evenly coated with three coats of the material by the appropriate method and air-dried for a specified period and exposed to accelerated weathering apparatus for a specified period.

exposure to the effects of heat, light and water with following test condition parameters:

C-2 PREPARATION OF TEST PANELS

- | | |
|-------------------|---|
| a) Lamp type | : UV 313 |
| b) Test cycle | : UV — (4 h at 60 °C
± 3 °C Condensation
— (4 h at 50 ± 3 °C) |
| c) Irradiance | : 0.67 W/m ² /nm |
| d) UVB wavelength | : 95 nm to 325 nm
(approx) |

C-2.1 Concrete Panels

For the accelerated weathering test preferably of sizes 150 mm × 75 mm or any other sizes suitable for accommodating in the UV condensation type apparatus.

C-2.2 Preparation of Panels

Select appropriate sizes of concrete panels [see IS 101 (Part 1/Sec 3)] with pH not more than 10 (preferably between 8 to 10) and brush uniformly one coat of the paint suitably thinned (see [6.4](#)). Air-dry for 8 h and apply a second coat of the paint and again air-dry for overnight and apply a third coat of the material. Air-dry for 8 h and then expose the panels to accelerated weathering apparatus.

C-3.2 Sample for registration shall be tested in duplicate in a suitable accelerated weathering apparatus (see [C-3.1](#)) and samples drawn from bulk supply shall be tested in a similar manner. The test panels shall be prepared as described under [C-2.2](#). Performance assessment will be done after exposure of 21 days using methods described under [C-3.3](#), [C-3.4](#), [C-3.5](#), [C-3.6](#), [C-3.7](#) and [C-3.8](#).

C-3 ACCELERATED WEATHERING TEST

C-3.3 Examine the conditions of the exposed films at an interval of 3 days for the following characteristics:

C-3.1 Accelerated Weathering Apparatus

An artificial weathering apparatus of UV condensation type for uniform and controlled

- a) Colour;
- b) Flaking;
- c) Cracking; and
- d) Chalking.

C-3.4 For the above examination, wash the right-hand half of the surface of test panels by pouring water and then wiping with soft cloth. Examine the same half of the test panels at each examination. At the end of the stipulated period for durability test, examine the two halves of the test panels for the above characteristics. The sample shall be considered satisfactory if the condition of the film in both the halves, the one washed periodically as well as the one washed only for the final examination, is satisfactory by the method of evaluation described in [C-3.5](#). Stray film failure due to extraneous causes other than climatic shall be ignored.

C-3.5 Method of Rating

The film of the unexposed panel shall be rated with the following basic values for the respective characteristics:

a) Possessing correct colour	25
b) Freedom from flaking (loss of adhesion and hence lifting)	25
c) Freedom from cracking	25
d) Freedom from chalking	25
Total	100

NOTE — The initial rating of the film maybe 100 or less according to the condition of colour, the rating or freedom from flaking, cracking and chalking being always the maximum in the case of unexposed films.

C-3.6 Evaluation of Exposed Films

In recording the condition of exposed films at each examination, express the observed relative values of different characteristics in percentages of the basic value allotted to each characteristic under [C-3.5](#). The allotment of performance value should be multiples of 10. For arriving at an assessment multiply the basic value for each characteristic (see [C-3.7](#)) by the percentage awarded for the performance in the test and divide the product so obtained by 100 to obtain the percentage award of the observed value of each characteristic. Take the sum total of these resulting values as the overall assessment.

C-3.7 The following table is intended to serve as a guide for the assessment of emulsion paint film after exposure.

C-3.8 Result of Exposure

Reckon the period for general breakdown of the exposed film from the date of commencement of exposure to the time when the overall assessment falls below 50 percent or when the performance value of any one characteristic falls below 25 percent of the basic value adopted for that characteristic. In the example given above although the overall assessment is 52.50 percent, yet the film is to be regarded as having generally broken down because the performance value of chalking has fallen below 25 percent of its basic value.

<i>Sl No.</i>	<i>Characteristic</i>	<i>Basic Value</i>	<i>Performance Value</i>	<i>Assessment Value</i>
(1)	(2)	(3)	(4)	(5)
i)	Possessing correct colour	25	70	17.50
ii)	Freedom from flaking (loss of adhesion and hence lifting)	25	70	17.50
iii)	Freedom from cracking	25	60	15.00
iv)	Freedom from chalking	25	10	2.50
			Total	52.50

ANNEX D

[Table 1, Sl No. (ii) and (v)]

DETERMINATION OF DRYING TIME AND FINISH

D-1 GENERAL

An asbestos cement panel is evenly coated with the material by appropriate method and air-dried for a specified time. Another coat is applied at the end of the specified time. The panel is examined for drying time and finish.

D-2 PREPARATION OF PANELS

D-2.1 Concrete Panels

Concrete panel of 100 mm × 150 mm size [see IS 101 (Part 1/Sec 3)]. Apply by appropriate method (for example, brushing) one coat of the material to give a wet film of approximate thickness of 50 micron on the panel.

D-3 PROCEDURE

Follow the procedure as prescribed in 5.1 and 5.2 of IS 101(Part 3/Sec 1).

D-4 OBSERVATIONS

D-4.1 For Drying Time

The material shall be deemed to have complied with the requirements of this standard for drying if the film becomes surface dry at the end of specified time limit as in Sl No. (ii) (a) of [Table 1](#). The material shall be deemed to have complied with the requirements of this standard for hard dry if a second coat of the material can be applied satisfactorily on the first coat at the end of prescribed time limit for surface dry and the drying time of second coat does not exceed the maximum specified time limit as in Sl No. (ii) (b) of [Table 1](#).

D-4.2 For Finish

Examine the panel after applying the second coat as. The material shall be deemed to have complied with the requirement of this standard for finish, if the composite film gives a smooth and uniform finish.

ANNEX E

[Table 1, Sl No. (vii)]

DETERMINATION OF COLOUR

E-1 GENERAL

The colour of the material applied on a white unglazed art paper is compared visually in diffused daylight with that of the standard or agreed colour.

E-2 PROCEDURE

E-2.1 Illumination for Colour Matching

As prescribed in IS 101(Part 4/Sec 2).

E- 2.2 Observer

As prescribed in IS 101 (Part 4/Sec 2).

E-2.3 Test Panels and Reference Standards

Test panels are of white unglazed art paper of sizes at least 150 mm × 150 mm. Reference standards are as prescribed in 2.4.2 of IS 101 (Part 4/Sec 2).

E-2.4 Preparation and Coating of Test Panels

Apply the paint to give a wet film thickness of approximately 50 microns by appropriate method

(for example, brushing) evenly on a 150 mm × 150 mm white unglazed art paper. Allow the coated test panel to dry in a vertical position shielded from air currents, in absence of direct sunlight and under standard atmospheric conditions of 27 °C ± 2 °C and 65 percent ± 5 percent relative humidity. When the film is surface dry, apply a second coat of the material to give again a wet film thickness of approximately 50 micron and air-dry.

E-2.5 Procedure for Colour Matching

After 24 h compare the colour of the film with that of a standard or, previously agreed colour visually in diffused daylight by the method as prescribed in 2.5 of IS 101 (Part 4/Sec 2).

E-3 OBSERVATIONS

The material shall be deemed to have passed the test, if the colour of the material matches with the standard or previously agreed colour.

ANNEX F

[Table 1, Sl No. (ix)]

DETERMINATION OF RESISTANCE TO ALKALI

F-1 GENERAL

The material is applied to concrete panel and the bleaching effect is examined. In order to give a basis for comparison, one-half of the panel is sealed with alkali-resistant solvent based primer. The method is also known as lime burning test.

F-2 MATERIAL

F-2.1 Concrete Panels

Concrete Panel of 150 mm × 100 mm size and having a pH of not less than 10 [see IS 101 (Part 1/ Sec 3)].

F-2.2 Alkali-resistant solvent-based primer (see IS 109).

F-2.3 Phthalocyanine Blue Pigment Paste

Prepare using phthalocyanine pigment [see IS 3574 Part 2)].

F-3 PROCEDURE

Select a panel as in [F-2.1](#) and take the alkali resistant solvent-based primer as in [F-2.2](#).

Condition both of them at (27 ± 2) °C for 1 h and seal one half of the panel by brushing the primer. Dry the panel for the period of hard dry stipulated in IS 109. Apply the material with a 300 micron block spreader to the entire panel and before application, condition the sample and the sealed panel at a temperature of (27 ± 2) °C for 1 h. Leave the coating dry. Put the panel over a nylon sponge placed in tray containing water. Make sure that sponge is completely wet and it wets the panel. Remove the panel after 48 h and leave it until dry. If the plastic emulsion paint under test is not coloured, it shall be tinted to a light blue shade using suitable phthalocyanine pigment paste, before application. Leave the coating until dry and when dry examine the panel for difference in colour between the sealed and the unsealed halves.

F-4 OBSERVATIONS

The material shall be deemed to have passed the test, if the colour difference between the unsealed and the sealed halves is not appreciable when examined visually.

ANNEX G

[Table 1, Sl No. (x)]

DETERMINATION OF WASHABILITY AND CLEANABILITY

G-1 GENERAL

The painted panels are subjected to wet rubbing in the abrasion test apparatus at a specified speed and load of the brush. The panels are examined at the end of the stipulated oscillations for film defects.

G-2 APPARATUS

G-2.1 Wet Abrasion Tester

As shown in [Fig. 1](#) and having the following accessories:

- a) Washing unit — of such a construction as to hold the brush in a box or holder which moves backwards and forwards in a straight line across the test panels at the rate of 38 ± 2 strokes per minute;

- b) Trays — water-tight to hold the panels;
- c) Brush — of polyurethane foam of density approximately 25 k/m^3 , with arrangements for weighing the brush with specified loads; and of size 85 mm × 36 mm × 12 mm; and
- d) Fractional horse power motor — of suitable speed to regulate the oscillations of the brush.

G-3 REAGENTS

G-3.1 Soap Solution

Dissolve 0.5 g of soap (conforming to Type I of IS 285) previously dried at 105 ± 2 °C for 30 min), in distilled water to give 0.5 percent (m/v) solution.

G-4 PROCEDURE

G-4.1 Preparation of the Panel

Clean a ground glass panel, 475 mm × 170 mm × 4 mm in size as prescribed in 5 of IS 101 (Part 1/Sec 3). Apply uniformly a coat of the undercoating enamel using a film applicator to give a wet film thickness of 35 to 38 micron and stove at 120 °C for 30 min. Rub down with No. 280 emery paper and wipe until the gloss is removed completely. Apply uniformly a coat of the material by brushing over the dried undercoat to give a wet film thickness of 150 micron Allow this to air-dry for 168 h.

G-4.2 Dip the brush in distilled water at 25 °C to 30 °C for 30 min to a depth of 12 mm. Shake off excess water and soak in the soap solution for

5 min. Fix the painted test panel in the tray in position with painted surface upwards. Fix the brush in its holder having a total load of 0.5 kg and adjust the stroke in such a way that not less than 10 mm of the film is left free on both ends. Start the oscillations of the brush. Keep the panel wet by adding soap solution at the rate of 10 drops to 12 drops per minute in the path of the brush. At the end of 4 000 oscillations, remove the panel. Wash with water, allow to dry, and examine the film for any defects.

G-5 OBSERVATIONS

The material shall be deemed to have passed the test if the material does not show film defects like blistering, exposure of undercoat, e and d colour fading.

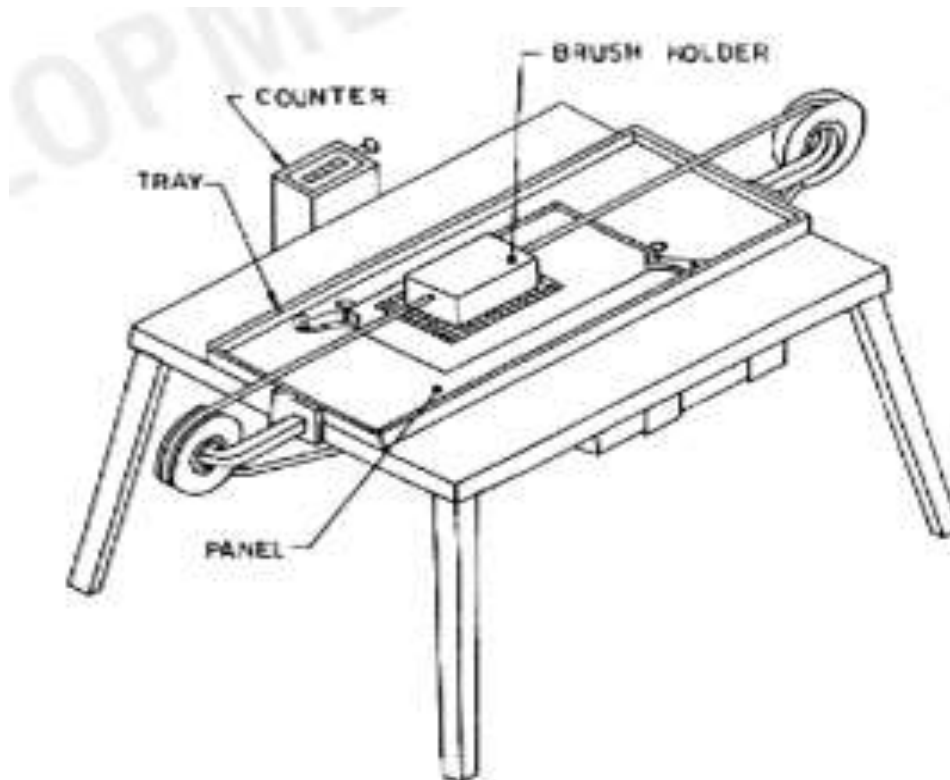

FIG. 1 WET ABRASION TESTER

ANNEX H

[Table 1, Sl No. (xi)]

TEST FOR ACCELERATED STORAGE STABILITY

H-1 GENERAL

The material is subjected to extremes of temperature and then tested for thinning and application properties.

H-2 PROCEDURE

Fill two clean, dry 500 ml metal containers (conforming to IS 1407) with 250 ml of the material leaving usual spillage and seal the lid tightly to avoid leakage. Keep one of the containers at $(-5 \pm 1) ^\circ\text{C}$ and the other at $(60 \pm 2) ^\circ\text{C}$ in an electrically heated oven for 48 h. Take out the sample containers and

keep them at room temperature for 24 h thereafter. Subsequently examine the material in the two containers.

H-3 OBSERVATIONS

The material shall be deemed to have passed this test, if it is found to be free from lumps, skins, settling and is capable of thinning suitably for application by appropriate method.

NOTE — Keep the paint sample in the oven and gradually increase the temperature $60 ^\circ\text{C}$.

ANNEX J

[Table 1, Sl No. (xii)]

DETERMINATION OF RECOATING PROPERTIES

J-1 GENERAL

The material is converted into brushing consistency and a coat applied on a dry concrete panel [see IS 101 (Part 1/Sec 3)]. After allowing to dry for a specified time, a second coat is applied to test the ability of the material to take the second coat.

J-2 PROCEDURE

Thin the material mixing with water to produce material of a suitable consistency for application by brushing. Apply two coats of the mixed material on a clean dry concrete panel [see IS 101 (Part 1/Sec 3)] of size 100 mm \times 150 mm at an interval of 4 h for classes A and B material and 8 h for classes

C and D material between coats, there shall be no lifting of the underlying coats.

NOTE — Drying time denotes time for hydration and hardening of the paint film and not for evaporation of moisture.

J-3 OBSERVATIONS AND RESULTS

The paint shall be deemed to have complied with the requirements of this standard, if this second coat of this same paint can be applied over the first coat without lifting, working up, rolling up or softening of the first coat and shall not exhibit colour separation, sagging, pitting, flaking or cracking.

ANNEX K

(Foreword)

COMMITTEE COMPOSITION

Paints, Varnishes and Related Products Sectional Committee, CHD 20

<i>Organization</i>	<i>Representative(s)</i>
Institute of Chemical Technology, Mumbai	PROF P. A. MAHANWAR (<i>Chairperson</i>)
Akzo Nobel Coatings India Pvt Ltd, Gurugram	SHRI SANATAN HAJRA
Asian Paints Ltd, Mumbai	SHRI RAJEEV KUMAR GOEL SHRI RAJES BARDIA (<i>Alternate</i>)
Berger Paints India Ltd, Howrah	SHRI TAPAN KUMAR DHAR SHRI SWAGATA CHAKROBORTY (<i>Alternate</i>)
Bharat Heavy Electricals Ltd, Tiruchirapalli	SHRI K. SRINIVASAN SHRI K. ANANDA BABU (<i>Alternate</i>)
Central Building Research Institute, Roorkee	DR SUKHDEO R. KARADE DR P. C. THAPLIYAL (<i>Alternate</i>)
Directorate General of Quality Assurance, New Delhi	SHRI A. K. KANAUIA SHRI B. S. TOMAR (<i>Alternate</i>)
Engineers India Limited, New Delhi	SHRI S. GHOSHAL SHRI A. SATYA SRIDHAR (<i>Alternate</i>)
Indian Institute of Technology, Mumbai	PROF SMRUTIRANJAN PARIDA
Institute of Chemical Technology, Mumbai	SHRI D. V. PINJARI
Kansai Nerolac Paints Ltd, Mumbai	SHRI LAXMAN NIKAM SHRI MANOJ KUMAR SOMANI (<i>Alternate</i>)
Meta Chem Paints and Adhesives Private Limited, Nashik	SHRI BISWANATH PANJA SHRI HEMANT KULKARNI (<i>Alternate</i>)
National Test House (ER), Kolkata	DR BRIJ MOHAN SINGH BISHT SHRI SUDHAKAR JAISWAL
Naval Materials Research Laboratory (NMRL), Thane	DR T. K. MAHATO DR G. GUNASEKARAN (<i>Alternate</i>)
Office of the Micro Small & Medium Enterprises (MSME), New Delhi	SHRIMATI M. ANNABACKIAM SHRIMATI M. S. RAMMIYA (<i>Alternate</i>)
Pidilite Industries Ltd, Mumbai	SHRI RAMESH KASHYAP SHRI SUSHANT PANGAM (<i>Alternate</i>)
Research Designs & Standards Organization, Lucknow	SHRI P. K. BALA SHRI K. P. SINGH (<i>Alternate</i>)
Shriram Institute for Industrial Research, Delhi	SHRI MOHAN SINGH CHAUHAN
SSPC India Chapter, Kolkata	DR BUDDHADEB DUARI SHRI ANIL SINGH (<i>Alternate</i>)
The Shipping Corporation of India Ltd, Mumbai	SHRI N. K. TRIPATHI SHRI SUSHIL ORAON (<i>Alternate</i>)
Voluntary Organisation in Interest of Consumer Education (VOICE), New Delhi	SHRI M. A. U. KHAN DR RAJIV JHA (<i>Alternate</i>)
In Personal Capacity (<i>Flat 1303, Blooming Heights, Pacific Enclave, Powai, Mumbai - 400076</i>)	DR B. P. MALLIK

<i>Organization</i>	<i>Representative(s)</i>
In Personal Capacity (2, Block Mann Street, Kolkata - 700013)	DR SUNIL KUMAR SAHA
BIS Directorate General	A. K. LAL SCIENTIST 'F'/SENIOR DIRECTOR AND HEAD (CHEMICAL) [REPRESENTING DIRECTOR GENERAL (<i>Ex-officio</i>)]

Member Secretary
SHRI PUSHPENDRA KUMAR
SCIENTIST 'B'/ASSISTANT DIRECTOR
(CHEMICAL), BIS

(Continued from second cover)

In recognition of the substantial consequences of volatile organic compounds (VOC) on the environment and human health, this second revision has been taken up to limit the VOC content in paint products. This second revision aims to promote the usage of low VOC or VOC-free products, marking a significant step towards fostering a healthier and more sustainable environment. The prescribed limits have been carefully established, taking into account the current capabilities of small, medium, and large-scale manufacturers to produce compliant products. The ultimate goal of these measures is the complete elimination of VOC from paint products. These initial limits are expected to serve as the foundation for future reductions, encouraging manufacturers to develop and adopt innovative technologies and processes that facilitate the production of VOC-free paints.

Additionally, acknowledging the time constraints associated with the 12 month outdoor exposure test for durability requirements, and the availability of advanced simulation technologies like QUV, carbon arc, and xenon arc accelerated test methods, the need for this extended outdoor exposure has been withdrawn. Also, the gloss range of class A and B has been changed from (0 to 10) to (0 to 5) and (10 to 25) to (5 to 25) respectively and lead restriction limit has been decreased from 300 ppm to 90 ppm.

The composition of the Committee responsible for the formulation of this standard is given in Annex K.

For the purpose of deciding whether a particular requirement of this standard is complied with, the final value, observed or calculated, expressing the result of a test or analysis, shall be rounded off in accordance with IS 2 : 2022 'Rules for rounding off numerical values (*second revision*)'. The number of significant places retained in the rounded-off value should be the same as that of the specified value in this standard.

Bureau of Indian Standards

BIS is a statutory institution established under the *Bureau of Indian Standards Act, 2016* to promote harmonious development of the activities of standardization, marking and quality certification of goods and attending to connected matters in the country.

Copyright

BIS has the copyright of all its publications. No part of these publications may be reproduced in any form without the prior permission in writing of BIS. This does not preclude the free use, in the course of implementing the standard, of necessary details, such as symbols and sizes, type or grade designations. Enquiries relating to copyright be addressed to the Head (Publication & Sales), BIS.

Review of Indian Standards

Amendments are issued to standards as the need arises on the basis of comments. Standards are also reviewed periodically; a standard along with amendments is reaffirmed when such review indicates that no changes are needed; if the review indicates that changes are needed, it is taken up for revision. Users of Indian Standards should ascertain that they are in possession of the latest amendments or edition by referring to the website-www.bis.gov.in or www.standardsbis.in.

This Indian Standard has been developed from Doc No.: CHD 20 (24048).

Amendments Issued Since Publication

Amend No.	Date of Issue	Text Affected

BUREAU OF INDIAN STANDARDS

Headquarters:

Manak Bhavan, 9 Bahadur Shah Zafar Marg, New Delhi 110002

Telephones: 2323 0131, 2323 3375, 2323 9402

Website: www.bis.gov.in

Regional Offices:

Central : 601/A, Konnectus Tower -1, 6th Floor,
DMRC Building, Bhavbhuti Marg, New
Delhi 110002

Telephones

{ 2323 7617

Eastern : 8th Floor, Plot No 7/7 & 7/8, CP Block, Sector V,
Salt Lake, Kolkata, West Bengal 700091

{ 2367 0012
2320 9474

Northern : Plot No. 4-A, Sector 27-B, Madhya Marg,
Chandigarh 160019

{ 265 9930

Southern : C.I.T. Campus, IV Cross Road, Taramani, Chennai 600113

{ 2254 1442
2254 1216

Western : 5th Floor/MTNL CETTM, Technology Street, Hiranandani Gardens, Powai
Mumbai 400076

{ 25700030
25702715

Branches : AHMEDABAD, BENGALURU, BHOPAL, BHUBANESHWAR, CHANDIGARH, CHENNAI, COIMBATORE, DEHRADUN, DELHI, FARIDABAD, GHAZIABAD, GUWAHATI, HARYANA (CHANDIGARH), HUBLI, HYDERABAD, JAIPUR, JAMMU, JAMSHEDPUR, KOCHI, KOLKATA, LUCKNOW, MADURAI, MUMBAI, NAGPUR, NOIDA, PARWANOO, PATNA, PUNE, RAIPUR, RAJKOT, SURAT, VIJAYAWADA.