

दंत चिकित्सा — पॉलिमर-आधारित  
रेस्टोरेटिव सामग्री (ISO 4049 : 2019,  
संशोधित)  
(दूसरा पुनरीक्षण)

Dentistry — Polymer-Based  
Restorative Materials (ISO 4049 :  
2019, MOD)

( Second Revision )

ICS 11.060.10

© BIS 2022



भारतीय मानक ब्यूरो  
BUREAU OF INDIAN STANDARDS  
मानक भवन, 9 बहादुर शाह ज़फर मार्ग, नई दिल्ली - 110002  
MANAK BHAVAN, 9 BAHADUR SHAH ZAFAR MARG  
NEW DELHI - 110002

[www.bis.gov.in](http://www.bis.gov.in) [www.standardsbis.in](http://www.standardsbis.in)

## NATIONAL FOREWORD

This Indian Standard (*second revision*) which is modified adoption of ISO 4049 : 2019 ‘Dentistry — Polymer-based restorative materials’ issued by the International Organization for Standardization (ISO), was adopted by the Bureau of Indian Standards on the recommendation of the Dentistry Sectional Committee and after approval of the Medical Equipment and Hospital Planning Division Council.

This standard was originally published in 1981 and revised in 2019. The second revision has been undertaken to align it with latest edition of ISO 4049 : 2019. After publication of this standard, IS 10011 : 2019/ISO 4049 : 2009 stands withdrawn.

The text of ISO Standard has been approved as suitable for publication as an Indian Standard without deviations. Certain conventions are however not identical to those used in Indian Standards. Attention is particularly drawn to the following:

- a) Wherever the words ‘International Standard’ appear referring to this standard, they should be read as ‘Indian Standard’
- b) Comma (,) has been used as a decimal marker while in Indian Standards, the current practice is to use a point (.) as the decimal marker.

In this adopted standard, reference appears to certain International Standards for which Indian Standards also exist. The corresponding Indian Standards which are to be substituted in their respective places are listed below along with their degree of equivalence for the editions indicated:

<i>International Standard</i>	<i>Corresponding Indian Standard</i>	<i>Degree of Equivalence</i>
ISO 1942 Dentistry — Vocabulary	IS 17895 : 2022/ISO 1942 : 2020 Dentistry — vocabulary	Identical
ISO 3696:1987 Water for analytical laboratory use — Specification and test methods	IS 1070:1992 Reagent grade water — Specification ( <i>third revision</i> )	Modified
ISO 7491:2000 Dental materials — Determination of colour stability	IS 12181: 2018/ISO 7491 : 2000, Dental materials — Determination of colour stability ( first revision )	Identical
ISO 8601-1 : 2019 Date and time — Representations for information interchange — Part 1: Basic rules	IS/ISO 8601-1 : 2019 Date and time — Representations for information interchange : Part 1 Basic rules	Identical
ISO 8601-2 : 2019 Date and time — Representations for information interchange — Part 2: Extensions	IS/ISO 8601-2 : 2019 Date and time — Representations for information interchange : Part 2 Extensions	Identical
ISO 13116 : 2014 Dentistry — Test method for determining radio-opacity of materials	IS 17696 : 2021/ISO 13116 : 2014 Dentistry — test method for determining radio - Opacity of materials	Identical
ISO 17304 : 2013 Dentistry — Polymerization shrinkage: Method for determination of polymerization shrinkage of polymer-based materials	IS/ISO 17304 : 2013 Dentistry — Polymerization shrinkage: Method for determination of polymerization shrinkage of polymer-based restorative materials	Identical

(Continued to third cover)

# Contents

Page

<b>Introduction</b> .....	<b>v</b>
<b>1 Scope</b> .....	<b>1</b>
<b>2 Normative references</b> .....	<b>1</b>
<b>3 Terms and definitions</b> .....	<b>1</b>
<b>4 Classification</b> .....	<b>2</b>
4.1 Type.....	2
4.2 Class.....	2
<b>5 Requirements</b> .....	<b>2</b>
5.1 Biocompatibility.....	2
5.2 Physical and chemical properties.....	2
5.2.1 General.....	2
5.2.2 Film thickness, luting materials.....	3
5.2.3 Working time, Class 1 and Class 3 restorative materials, excluding luting materials.....	3
5.2.4 Working time, Class 1 and Class 3 luting materials.....	3
5.2.5 Setting time, Class 1 materials.....	3
5.2.6 Setting time, Class 3 materials.....	3
5.2.7 Sensitivity to light, Class 2 materials.....	3
5.2.8 Depth of cure, Class 2 materials excluding luting materials.....	3
5.2.9 Flexural strength.....	4
5.2.10 Water sorption and solubility.....	4
5.3 Shade of restorative materials.....	4
5.4 Colour stability after irradiation and water sorption.....	4
5.5 Radio-opacity.....	4
<b>6 Sampling</b> .....	<b>5</b>
<b>7 Test methods</b> .....	<b>5</b>
7.1 General reagent — Water.....	5
7.2 Test conditions.....	5
7.3 Inspection.....	6
7.4 Preparation of test specimens.....	6
7.5 Measurement of film thickness of luting materials.....	6
7.5.1 Apparatus.....	6
7.5.2 Test procedure.....	8
7.5.3 Treatment of results.....	9
7.6 Working time, Class 1 and Class 3 restorative materials, excluding luting materials.....	10
7.6.1 Apparatus.....	10
7.6.2 Procedure.....	11
7.6.3 Treatment of results.....	11
7.7 Working time, Class 1 and Class 3 luting materials.....	12
7.7.1 Apparatus.....	12
7.7.2 Procedure.....	12
7.7.3 Treatment of results.....	12
7.8 Setting time, Class 1 and Class 3 materials.....	12
7.8.1 Apparatus for the determination of setting time of Class 1 and Class 3 restorative materials.....	12
7.8.2 Apparatus for the determination of setting time of Class 1 and Class 3 luting materials.....	12
7.8.3 Procedure.....	12
7.8.4 Treatment of results.....	13
7.9 Sensitivity to light, Class 2 materials.....	13
7.9.1 Apparatus.....	14

7.9.2	Procedure.....	14
7.9.3	Treatment of results.....	15
7.10	Depth of cure, Class 2 materials excluding luting materials.....	15
7.10.1	Apparatus.....	15
7.10.2	Procedure.....	15
7.10.3	Treatment of results.....	16
7.11	Flexural strength.....	16
7.11.1	Apparatus.....	16
7.11.2	Preparation of test specimens.....	17
7.11.3	Procedure.....	18
7.11.4	Treatment of results.....	18
7.12	Water sorption and solubility.....	19
7.12.1	Apparatus.....	19
7.12.2	Preparation of test specimens.....	20
7.12.3	Procedure.....	21
7.12.4	Treatment of results.....	21
7.13	Shade and colour stability after irradiation and water sorption.....	22
7.13.1	General.....	22
7.13.2	Apparatus.....	22
7.13.3	Preparation of test specimens.....	23
7.13.4	Procedure.....	23
7.13.5	Colour comparison for shade.....	23
7.13.6	Colour comparison for colour stability.....	23
7.14	Radio-opacity.....	23
7.14.1	Perform the test in accordance with ISO 13116.....	23
7.14.2	Preparation of test specimens.....	23
7.14.3	Treatment of results.....	23
<b>8</b>	<b>Packaging, marking, instructions and information to be supplied by the manufacturer.....</b>	<b>24</b>
8.1	Packaging.....	24
8.2	Marking and instructions for use.....	24
8.3	Declaration of components.....	28
	<b>Bibliography.....</b>	<b>29</b>

## Introduction

Specific qualitative and quantitative requirements for freedom from biological hazard are not included in this document. It is recommended, however, that reference should be made to ISO 10993-1 and ISO 7405 when assessing possible biological or toxicological hazards.



*Indian Standard*

# DENTISTRY — POLYMER-BASED RESTORATIVE MATERIALS

## (ISO 4049 : 2019, MOD)

### 1 Scope

This document specifies requirements for dental polymer-based restorative materials supplied in a form suitable for mechanical mixing, hand-mixing, or intra-oral and extra-oral external energy activation, and intended for use primarily for the direct or indirect restoration of the teeth and for luting.

The polymer-based luting materials covered by this document are intended for use in the cementation or fixation of restorations and appliances such as inlays, onlays, veneers, crowns and bridges. This document does not cover those polymer-based luting materials that have an adhesive component within the structure of the material (see ISO/TS 16506).

The document does not cover polymer-based materials intended to prevent caries (see ISO 6874), core materials or those used for veneering metal sub-frames (see ISO 10477).

### 2 Normative references

The following documents are referred to in the text in such a way that some or all of their content constitutes requirements of this document. For dated references, only the edition cited applies. For undated references, the latest edition of the referenced document (including any amendments) applies.

ISO 1942, *Dentistry — Vocabulary*

ISO 3696:1987, *Water for analytical laboratory use — Specification and test methods*

ISO 7491:2000, *Dental materials — Determination of colour stability*

ISO 8601-1:2019, *Date and time — Representations for information interchange Part — 1: Basic rules*

ISO 8601-2:2019, *Date and time — Representations for information interchange Part — 2: Extensions*

ISO 13116:2014, *Dentistry — Test method for determining radio-opacity of materials*

ISO 17304:2013, *Dentistry — Polymerization shrinkage: Method for determination of polymerization shrinkage of polymer-based materials*

### 3 Terms and definitions

For the purposes of this document, the terms and definitions given in ISO 1942 and the following apply.

ISO and IEC maintain terminological databases for use in standardization at the following addresses:

- ISO Online browsing platform: available at <https://www.iso.org/obp>
- IEC Electropedia: available at <http://www.electropedia.org/>

#### 3.1

##### **opaque**

shade of an intensely pigmented polymer-based restorative material of low translucency

#### 3.2

##### **outer pack**

form of packaging used to combine a number of single dose containers or capsules

### 3.3 outermost packaging

form of packaging used to combine material and additional items, including instructions for use and any proportioning or mixing devices, that are supplied with the material

### 3.4 container capsule

primary packaging of the material

## 4 Classification

### 4.1 Type

For the purposes of this document, dental polymer-based restorative materials are classified into the following types.

- **Type 1:** Polymer-based restorative materials claimed by the manufacturer as suitable for restorations involving occlusal surfaces;
- **Type 2:** All other polymer-based restorative materials, and luting materials.

### 4.2 Class

The three classes of dental polymer-based restorative materials are as follows:

- **Class 1:** Materials whose setting is effected by mixing an initiator and activator (“Self-curing” materials).
- **Class 2:** Materials whose setting is effected by the application of energy from an external source, such as blue light or heat, (“external-energy-activated” materials, see also [Table 4](#), items 9 and 20). They are subdivided as follows:
  - 1) **Group 1:** Materials whose use requires the energy to be applied intra-orally;
  - 2) **Group 2:** Materials whose use requires the energy to be applied extra-orally. When fabricated, these materials will be luted into place.

Certain materials may be claimed by manufacturers to be both Group 1 and Group 2. In this event the material shall fulfil the requirements for both groups.

NOTE Class 2 luting materials fall into Group 1 only.

- **Class 3:** Materials that are cured by the application of external energy, and also have a self-curing mechanism present (“dual-cure” materials).

## 5 Requirements

### 5.1 Biocompatibility

For guidance on biocompatibility see ISO 7405 and ISO 10993-1.

### 5.2 Physical and chemical properties

#### 5.2.1 General

If a restorative material is supplied by the manufacturer in various shades, each shade, including opaque shades, shall be capable of satisfying all the requirements for sensitivity to the dental operating light



(5.2.7), depth of cure (5.2.8), shade (5.3) and colour stability (5.4) appropriate to the material type and class. If the material is supplied such that it can be “tinted” or “blended” to the user’s prescription, the material shall conform to the requirements both when used alone and when used with the maximum recommended proportion of tint or blender (see Table 4, item 19). Depth of cure (5.2.8) of luting materials shall not be tested.

Colour stability (5.4) of luting materials shall not be tested unless the manufacturer claims such a property.

In respect of the other requirements of 5.2 and those of 5.5, only one representative shade of restorative materials shall be tested. This representative shade shall be either that classified by the manufacturer as “Universal” or, in the event that no shade is so classified, that shade corresponding to “A3” in the Vita®<sup>1)</sup> classification of shade. However, if the manufacturer claims a higher value for radio-opacity (see 5.5 and Table 4, item 28) for any other shade, this claim shall be tested.

The requirements are summarized in Tables 1, 2 and 3.

### 5.2.2 Film thickness, luting materials

The film thickness of luting materials when determined in accordance with 7.5 shall be no more than 10 µm above any value claimed by the manufacturer and in any event shall be no greater than 50 µm.

### 5.2.3 Working time, Class 1 and Class 3 restorative materials, excluding luting materials

The working time for Class 1 and Class 3 restorative materials, excluding luting materials, determined in accordance with 7.6, shall be no less than 90 s.

### 5.2.4 Working time, Class 1 and Class 3 luting materials

When tested in accordance with 7.7, the material shall be capable of forming a thin layer; during its formation there shall be no detectable change in its homogeneity.

### 5.2.5 Setting time, Class 1 materials

The setting time for Class 1 restorative materials, excluding luting materials, determined in accordance with 7.8, shall be no more than 5 min. The setting time for Class 1 luting materials, determined in accordance with 7.8, shall be no more than 10 min.

### 5.2.6 Setting time, Class 3 materials

The setting time for Class 3 materials, determined in accordance with 7.8, shall be no more than 10 min.

### 5.2.7 Sensitivity to light, Class 2 materials

When tested in accordance with 7.9, the material shall remain physically homogeneous.

### 5.2.8 Depth of cure, Class 2 materials excluding luting materials

When determined in accordance with 7.10, the depth of cure of Class 2 restorative materials shall be no less than 1 mm if they are labelled by the manufacturer as opaque, or no less than 1,5 mm for other restorative materials.

In any event, the values for all materials shall not be more than 0,5 mm below the value stated by the manufacturer.

---

1) Vita® is a trade name of Vita Zahnfabrik, H Rauter GmbH & Co K G, Postfach 1338, D-79704 Bad Saeckingen, Germany. This information is given for the convenience of the users of this document and does not constitute an endorsement of this system by ISO.

### 5.2.9 Flexural strength

The flexural strength of polymer-based restorative materials determined in accordance with [7.11](#), shall be equal to or greater than the limits specified in [Table 1](#).

**Table 1 — Flexural strength**

Restorative materials		Flexural strength MPa minimum
Type 1	Class 1	80
	Class 2, Group 1	80
	Class 2, Group 2	100
	Class 3	80
Type 2 (including luting materials)	Class 1	50
	Class 2, Group 1	50
	Class 3	50

### 5.2.10 Water sorption and solubility

When determined in accordance with [7.12](#):

- a) the water sorption of all materials shall be equal to or less than 40 µg/mm<sup>3</sup>.
- b) the solubility of all materials shall be equal to or less than 7,5 µg/mm<sup>3</sup>.

## 5.3 Shade of restorative materials

When the material is assessed in accordance with [7.13](#) and ISO 7491, the shade of the set material shall closely match that of the manufacturer's shade guide. If a shade guide is not supplied by the manufacturer, then the manufacturer shall nominate a commercially available shade guide that shall be used in assessing conformance with this requirement (see [Table 4](#), items 13 and 25). In addition, the set material shall be evenly pigmented when viewed without magnification.

## 5.4 Colour stability after irradiation and water sorption

When the material is tested in accordance with [7.13](#) and ISO 7491, no more than a slight change in colour shall be observed. In respect of luting materials, colour stability shall be tested only in the event of a manufacturer's claim for colour stability. In the event of such a claim, no more than a slight change in colour shall be observed when the material is tested in accordance with [7.13](#) and ISO 7491.

## 5.5 Radio-opacity

**5.5.1** If the manufacturer claims that the material is radio-opaque (see [Table 4](#), items 16 and 28), the radio-opacity, determined in accordance with [7.14](#), shall be equal to or greater than that of the same thickness of aluminium and no less than 0,5 mm below any value claimed by the manufacturer.

**5.5.2** This test shall be performed on a "universal" shade (see [5.2.1](#)) but if the manufacturer claims a value for another shade or shades that is at least twice the "universal" shade value, this other shade or shades shall be tested as described in [5.5.1](#) (see [Table 4](#), item 28).

NOTE Aluminium has a radio-opacity equivalent to that of dentine. Thus 1 mm of material having a radio-opacity equivalent to 1 mm of aluminium has a radio-opacity equivalent to that of dentine.

**Table 2 — Physical and chemical property requirements for restorative materials, excluding luting materials**  
(see [Table 1](#) for minimum flexural strength)

Material Class	Requirement (subclause)				
	Working time (5.2.3) s minimum	Setting time (5.2.5, 5.2.6) min maximum	Depth of cure <sup>a</sup> (5.2.8) mm minimum	Water sorption (5.2.10) µg/mm <sup>3</sup> maximum	Solubility (5.2.10) µg/mm <sup>3</sup> maximum
Class 1	90	5 (5.2.5)	—	40	7,5
Class 2	—	—	1,0 (opaque shade) 1,5 (others)	40	7,5
Class 3	90	10 (5.2.6)	—	40	7,5

<sup>a</sup> The values for all materials shall be no more than 0,5 mm below the value stated by the manufacturer.

**Table 3 — Physical and chemical property requirements for luting materials**

Material Class	Requirement (subclause)				
	Film thickness <sup>a</sup> (5.2.2) µm maximum	Working time (5.2.4) s minimum	Setting time (5.2.5, 5.2.6) min maximum	Water sorption (5.2.10) µg/mm <sup>3</sup> maximum	Solubility (5.2.10) µg/mm <sup>3</sup> maximum
Class 1	50	60	10 (5.2.5)	40	7,5
Class 2	50	—	—	40	7,5
Class 3	50	60	10 (5.2.6)	40	7,5

<sup>a</sup> The determined value shall be no more than 10 µm above any value claimed by the manufacturer.

## 6 Sampling

The test sample shall consist of packages prepared for retail sale from the same batch containing enough material to carry out the specified tests, plus an allowance for repeat tests, if necessary. 50 g should be sufficient.

## 7 Test methods

### 7.1 General reagent — Water

For the tests, use water prepared in accordance with ISO 3696:1987 Grade 2.

### 7.2 Test conditions

Unless otherwise specified by the manufacturer, prepare and test all specimens at (23 ± 2) °C. Control the relative humidity to ensure that it remains greater than 30 % and less than 70 % at all times. If the material was refrigerated for storage, allow it to attain (23 ± 2) °C before testing.

For Class 3 materials, the tests for working time (see [7.6](#)) and setting time (see [7.8](#)) shall be performed in the absence of activating radiation.

Ambient light, both natural and artificial, is capable of activating these materials. To control this, the test should be performed in a dark room with any artificial light filtered by a yellow filter<sup>2)</sup>.

### 7.3 Inspection

Inspect visually to check that requirements specified in [Clause 8](#) have been met.

### 7.4 Preparation of test specimens

For the preparation of Class 2 and Class 3 materials, reference shall be made to the manufacturer's instructions (see [Table 4](#), item 20) that state the external energy source or sources recommended for the materials to be tested. Care shall be taken to ensure that the source is in a satisfactory operating condition (see ISO 10650 for guidance.)

Mix or otherwise prepare the material in accordance with the manufacturer's instructions and the test conditions specified in [7.2](#).

Where fully-cured specimens are required for testing ([7.11](#) to [7.14](#)), it is important to ensure that the specimens are homogeneous after removal from the mould. There shall be no clefs, voids, discontinuities or air inclusions present when viewed without magnification.

Some polymer-based materials, particularly certain luting materials, have a chemical affinity for base metals. This property creates difficulty when removing specimens from metal moulds. Reference shall be made to the information supplied by the manufacturer (see [Table 4](#), item 26) regarding this property and, if it is claimed, moulds for the preparation of specimens of such materials may be made from non-metallic material such as high-density polyethylene.

### 7.5 Measurement of film thickness of luting materials

#### 7.5.1 Apparatus

**7.5.1.1 Two glass plates**, optically flat, square or circular, each having a contact surface area of  $(200 \pm 25)$  mm<sup>2</sup>. Each plate shall be of a uniform thickness no less than 5 mm.

**7.5.1.2 Loading device** of the type illustrated in [Figure 1](#), or an equivalent means, whereby a force of  $(150 \pm 2)$  N may be applied vertically to the specimen via the upper glass plate. In [Figure 1](#), the anvil that

---

2) Polyester filter 101, Lee Filters, Andover, Hants, UK is an example of a suitable product available commercially. This information is given for the convenience of the users of this document and does not constitute an endorsement of this product by ISO. Alternatives are long-pass filters with a cut off above 525 nm.

is attached to the bottom of the rod shall be horizontal and parallel to the base. The load shall be applied smoothly and in such a manner that no rotation occurs.

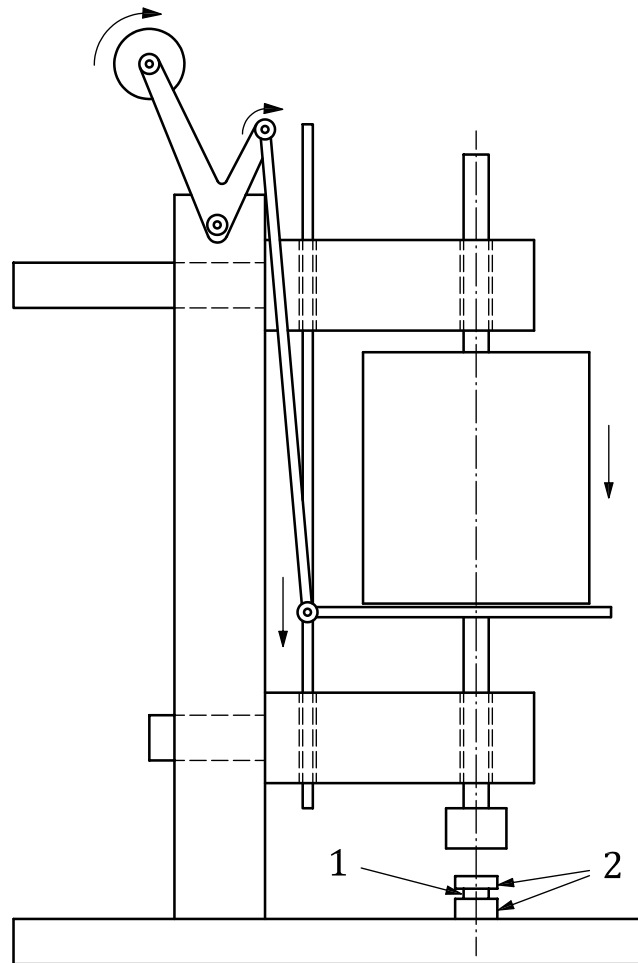

**Key**

- 1 specimen
- 2 glass plates

**Figure 1 — Loading device for use in the film thickness test (see 7.5)**

A holder may be used to assist in the positioning of the plates. Such a device consists of a baseplate with three vertical pins to align circular plates or four pins to align square plates (See [Figure 2](#)).

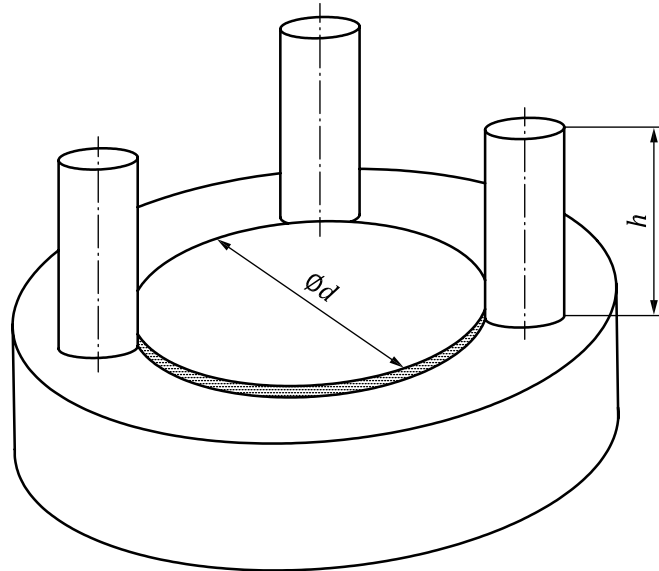

NOTE 1 The diameter,  $d$ , slightly exceeds the diameter of the glass plates.

NOTE 2 The height,  $h$ , of the pins is 1,5 times the height of one of the glass plates.

**Figure 2 — Holder to assist stabilization of the glass plates (see 7.5)**

**7.5.1.3 External energy source** (for Class 2 and Class 3 materials), as recommended by the manufacturer for use with the material under test.

**7.5.1.4 Micrometer** or equivalent measuring instrument, accurate to 0,001 mm.

**7.5.1.5 Timer** accurate to 1 s.

## 7.5.2 Test procedure

### 7.5.2.1 Preliminary steps

Measure, to an accuracy of 0,001 mm, the combined thickness of the two optically-flat glass plates stacked in contact with the micrometer (reading A). Remove the upper plate and place between 0,02 ml and 0,10 ml of the test material treated in accordance with the manufacturer's instructions in the centre of the lower plate and place this centrally below the loading device on its lower plate. Replace the second glass plate centrally onto the test specimen in the same orientation as in the original measurement. The holder (Figure 2) is helpful.

The volume of material needed to fill completely the space between the glass plates will vary according to the material's viscosity. A preliminary test may be used to determine the appropriate volume.

### 7.5.2.2 Class 1 materials

At  $(60 \pm 2)$  s after mixing Class 1 materials, carefully apply a force of  $(150 \pm 2)$  N vertically and centrally to the specimen via the top plate for  $(180 \pm 10)$  s. Ensure that the cement has completely filled the space between the glass plates. At least 10 min after the commencement of mixing, remove the plates from the loading device and measure the combined thickness of the two glass plates and the specimen film, again taking the reading in the centre of the plates (reading B).

Record the difference between reading A and reading B, to the nearest micrometre, as the film thickness of the luting material.

Carry out five determinations.

### 7.5.2.3 Class 2 and Class 3 materials

Immediately after dispensing Class 2 materials or after mixing Class 3 materials, carefully apply a force of  $(150 \pm 2)$  N vertically and centrally to the specimen via the top plate for  $(180 \pm 10)$  s. Ensure that the cement has completely filled the space between the glass plates. Immediately after the period of loading release the loading system and irradiate the specimen through the centre of the upper glass plate for twice the recommended exposure time.

NOTE This irradiation is not intended to cure the material totally, but to stabilize the specimen for measurement.

After the irradiation of Class 2 and Class 3 materials, remove the plates from the loading device and measure the combined thickness of the two glass plates and the specimen film, again taking the reading in the centre of the plates (reading B).

Record the difference between reading A and reading B to the nearest micrometre as the film thickness of the luting material.

Carry out five determinations.

### 7.5.3 Treatment of results

Record the film thickness and report as follows:

- a) If at least four of the values are equal to or less than  $50 \mu\text{m}$ , the material is deemed to have conformed to the first requirement of [5.2.2](#).
- b) If three or more values are greater than  $50 \mu\text{m}$ , the material is deemed to have failed.
- c) If only three of the values are equal to or less than  $50 \mu\text{m}$ , repeat the whole test. If one or more of the values is greater than  $50 \mu\text{m}$  on the second occasion, the material is deemed to have failed the whole test.
- d) If the manufacturer claims a specific value for film thickness, at least four of the five values shall be no more than  $10 \mu\text{m}$  greater than the claimed value in order to conform to the second requirement of [5.2.2](#).

## 7.6 Working time, Class 1 and Class 3 restorative materials, excluding luting materials

### 7.6.1 Apparatus

#### 7.6.1.1 Thermocouple apparatus, as shown in [Figure 3](#).

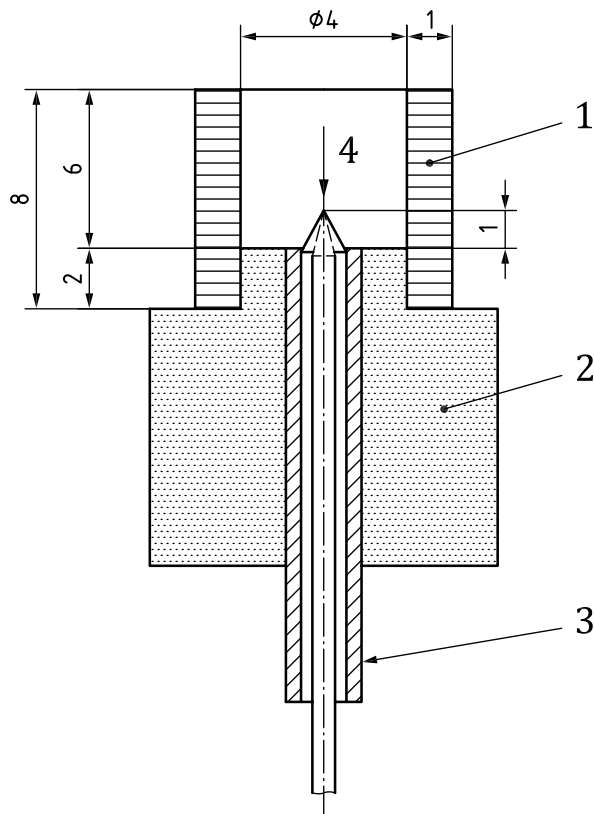

#### Key

- 1 polyethylene tubing
- 2 polyamide block
- 3 stainless steel tube
- 4 thermocouple-cone of solder

**Figure 3 — Apparatus for determination of working and setting times (see [7.6](#), [7.8](#))**

The apparatus consists of a piece of high-density polyethylene (or similar material) tubing, 1, located on a block of polyamide or similar material, 2, having a hole into which is inserted a stainless-steel tube, 3, containing a stabilized thermocouple 4.

Tube 1 shall be 8 mm long, 4 mm in internal diameter and have a wall thickness of 1 mm. The locating part of block 2 shall be 4 mm in diameter and 2 mm high. When assembled, the two components shall form a specimen well 6 mm high × 4 mm in diameter. In order to facilitate removal of the specimen after testing, the thermocouple 4 shall have a conical tip which protrudes 1 mm into the base of the specimen well. The tolerances on the above-mentioned dimensions are ± 0,1 mm.

The thermocouple shall consist of wires (0,20 ± 0,05) mm in diameter, made of a material (e.g. copper/constantan) capable of registering temperature changes in a specimen of setting material to an accuracy of 0,1 °C. The thermocouple is connected to an instrument (e.g. voltmeter or chart recorder) capable of recording the temperature to that accuracy.

#### 7.6.1.2 Timer accurate to 1 s.



### 7.6.2 Procedure

Prepare the test material in accordance with the manufacturer's instructions (see [Table 4](#)) and start timing from the moment mixing is begun. Maintain the mould at  $(23 \pm 1) ^\circ\text{C}$  and, 30 s after the start of mixing, place the mixed material in the mould and record the temperature,  $T_0$ , of the material. Maintain the apparatus ([7.6.1.1](#)) at  $(23 \pm 1) ^\circ\text{C}$  and continuously record the temperature of the material until the maximum temperature has passed.

A typical recording trace is shown in [Figure 4](#). As soon as the material is inserted into the mould, the temperature will rise slightly to  $T_1$  and then fall until it becomes steady at  $T_0$  and then starts to increase. The point at which the temperature begins to increase denotes the start of the setting reaction and, therefore, the end of the working time. Determine this point by drawing a horizontal base line at  $(T_0 \pm 0,1) ^\circ\text{C}$  and recording  $t_w$  at the point of intersection with the trace. The results are extremely temperature-dependent and slight variations within the permitted temperature range will cause variations of several seconds. Record the working time,  $t_w$ , from the start of mixing until the temperature starts to increase.

Carry out five determinations.

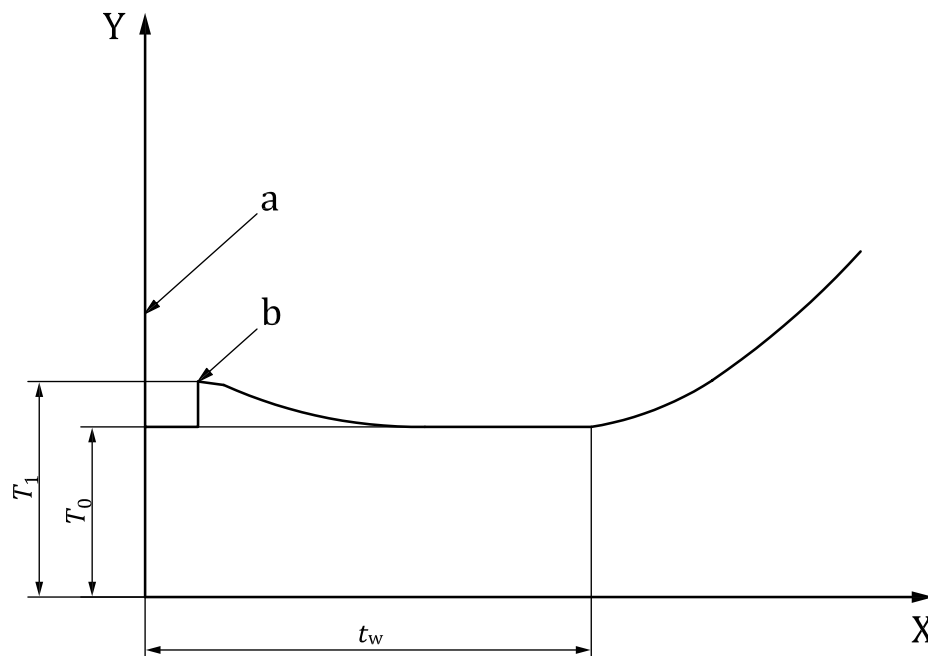

#### Key

- X time
- Y temperature
- a Start of mixing
- b Insertion

**Figure 4 — Determination of working time (see [7.6.2](#))**

**NOTE** The schematic diagram shows the temperature at the time of insertion,  $T_0$ , the slight temperature increase immediately after insertion, to  $T_1$ , and the initial time of temperature increase which denotes the start of the setting reaction and, therefore, the end of the working time,  $t_w$ .

### 7.6.3 Treatment of results

Record the working times and report as follows:

- a) If at least four of the times obtained are equal to or longer than 90 s, the material is deemed to have conformed to the requirement of [5.2.3](#).

- b) If three or more of the times are shorter than 90 s, the material is deemed to have failed.
- c) If only three of the times are equal to or longer than 90 s, repeat the whole test. If one or more times are shorter than 90 s on the second occasion, the material is deemed to have failed the whole test.

## 7.7 Working time, Class 1 and Class 3 luting materials

### 7.7.1 Apparatus

#### 7.7.1.1 Two glass microscope slides.

#### 7.7.1.2 Timer accurate to 1 s.

### 7.7.2 Procedure

At 60 s after the completion of mixing, place a spheroidal mass of approximately 30 mg of material on a glass microscope slide ([7.7.1.1](#)) and immediately press the second microscope slide against the material with a shearing action to produce a thin layer.

Visually inspect the material to see whether it is physically homogeneous.

NOTE During this test, if the material has begun to set, clefts and voids will appear in the specimen when the thin layer is being produced. Alternatively, with rapid setting materials, there will be an increase in viscosity that will prevent the layer being produced.

Repeat the entire procedure twice, using a new sample for each test. Record the results of all three tests.

### 7.7.3 Treatment of results

If, on visual inspection, the material of all three samples remains physically homogeneous and has formed a thin layer, the material is deemed to have conformed to the requirement of [5.2.4](#).

## 7.8 Setting time, Class 1 and Class 3 materials

### 7.8.1 Apparatus for the determination of setting time of Class 1 and Class 3 restorative materials

#### 7.8.1.1 Thermocouple apparatus, as specified in [7.6.1.1](#).

### 7.8.2 Apparatus for the determination of setting time of Class 1 and Class 3 luting materials

7.8.2.1 Thermocouple apparatus, as specified in [7.6.1.1](#) except that the tube A shall be 6 mm long and thus form a specimen well 4 mm in height. All other dimensions specified in [7.6.1.1](#) shall apply.

### 7.8.3 Procedure

Use the procedure specified in [7.6.2](#) but maintain the apparatus ([7.8.1](#)) at  $(37 \pm 1) ^\circ\text{C}$ .

Measure the time from the start of mixing until a plateau at maximum temperature is reached (see [Figure 5](#)). Extend the plateau backwards to meet an extension of the straight line of temperature increase. Record this time,  $t_s$ , as the setting time.

Perform the test five times.

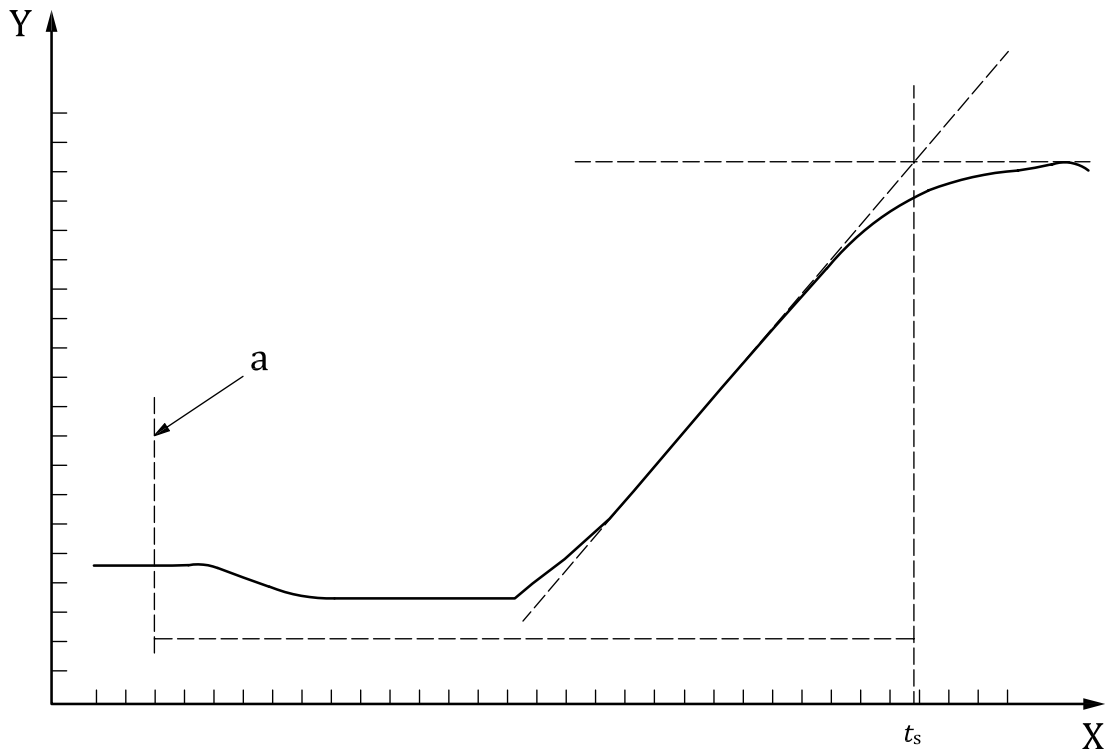
**Key**

- X time  
 Y temperature  
 a Start of mixing

NOTE The setting time,  $t_s$ , is determined by extending the plateau backwards to meet an extension of the straight line of temperature increase. This provides a distinct datum point.

**Figure 5 — Method for determining setting time (see 7.8)**

#### 7.8.4 Treatment of results

Record the setting times, refer to [Table 2](#) or [Table 3](#) for the particular material under test and report as follows:

- If at least four of the times obtained are no more than the value specified in [Table 2](#) or [Table 3](#) for the particular material, the material is deemed to have conform to the requirement of [5.2.5](#) or [5.2.6](#).
- If three or more of the times are longer than the value specified in [Table 2](#) or [Table 3](#) for the particular material, the material is deemed to have failed to conform to the requirement of [5.2.5](#) or [5.2.6](#).
- If only three of the times are no more than the value specified in [Table 2](#) or [Table 3](#) for the particular material, repeat the whole test. If one or more times are longer than the value specified in [Table 2](#) or [Table 3](#) for the particular material, the material is deemed to have failed to comply with the requirement of [5.2.5](#) or [5.2.6](#).

#### 7.9 Sensitivity to light, Class 2 materials

NOTE The purpose of this test is to determine whether the material remains manipulable during the placement of a restoration in the mouth when it will be exposed to ambient and the dental operating light.

## 7.9.1 Apparatus

**7.9.1.1 Xenon lamp**, or radiation source of equivalent performance with a colour temperature of 5 000 K to 7 000 K with ultraviolet filter inserted.

The ultraviolet filter shall be made of borosilicate glass with a transmittance < 1 % below 300 nm and > 90 % above 370 nm.

According to ISO 9680, the preferable colour temperature of dental operating lights is 4 500 K–6 400 K. Xenon lamps may change the spectral emission over time, therefore a periodic inspection or replacement is recommended.

**7.9.1.2 Neutral density filter** that does not change the wavelength distribution of the xenon lamp.

NOTE The neutral density filter (ND filter) is a light reducing filter that will reduce the light intensity from the xenon lamp without the significant modulation of the distance and the electric voltage. ND filters originally prepared for cameras are easily available.

**7.9.1.3 Two glass microscope slides/plates**

**7.9.1.4 Luxmeter**, capable of measuring illuminance of  $(2\ 900 \pm 200)$  lx to an accuracy of  $\pm 100$  lx.

**7.9.1.5 Height-adjustable table**

**7.9.1.6 Matt black cover** for the luxmeter.

This is intended to prevent reflection from the cell interfering with the observation of the specimen.

**7.9.1.7 Timer** accurate to 1 s.

## 7.9.2 Procedure

In a dark room, position the cell of the luxmeter (7.9.1.4) under the xenon lamp with the ultraviolet filter inserted (7.9.1.1).

Sufficient time should be allowed after switching on for the xenon lamp to reach a stable colour temperature.

Adjust the illuminance to  $(2\ 900 \pm 200)$  lx by applying one of the procedures described in a), b) or c) below, otherwise by applying any combination of these procedures.

- a) Modulate the distance between the xenon lamp (7.9.1.1) and the light receiving cell of the luxmeter (7.9.1.4) where the specimen will be placed using the height-adjustable table (7.9.1.5).
- b) Attenuate the electric voltage of the equipment for the xenon light source.
- c) Apply the neutral density filter (7.9.1.2).

NOTE If adjustment to the voltage is used, ensure that the colour temperature remains within the specified range.

Cover the cell with the matte black cover (7.9.1.6). Place a spheroidal mass of approximately 30 mg of material on a glass microscope slide (7.9.1.3), position the slide on top of the cell and expose it to the light for  $(60 \pm 5)$  s. Remove the slide with the sample from the irradiated area and immediately press the second microscope slide against the material with a shearing action to produce a thin layer.

Visually inspect the material to see whether it is physically homogeneous.

During this test, if the material has begun to set, discontinuities and voids will appear in the specimen when the thin layer is being produced. It may aid the inspection to compare the test specimen with one that has been produced in the absence of light.

Repeat the entire procedure twice, using a new sample of material for each test. Record the results of all three tests.

### 7.9.3 Treatment of results

If, on visual inspection, the material of all three samples remains physically homogeneous, the material is deemed to have conformed to the requirement of [5.2.7](#).

## 7.10 Depth of cure, Class 2 materials excluding luting materials

### 7.10.1 Apparatus

**7.10.1.1 Stainless steel mould**, for the preparation of a cylindrical specimen, 6 mm long and with a diameter 4 mm. If the manufacturer claims a depth of cure in excess of 3 mm the mould shall be at least 2 mm longer than twice the claimed depth of cure.

A mould release agent which does not interfere with the setting reaction, for example a 3 % solution of polyvinyl ether wax in hexane, may be used to facilitate removal of the specimen.

**7.10.1.2 Two glass slides/plates**, each of sufficient area to cover one side of the mould.

Standard glass microscope slides may be used.

**7.10.1.3 White filter paper**

**7.10.1.4 Film**, transparent to the activating radiation,  $(50 \pm 30)$   $\mu\text{m}$  thick, e.g. polyester.

**7.10.1.5 External energy source**, as recommended by the manufacturer for use with the test material (see [Table 4](#), item 20).

**7.10.1.6 Micrometer**, accurate to at least 0,005 mm.

**7.10.1.7 Plastics spatula**

### 7.10.2 Procedure

Place the mould ([7.10.1.1](#)) onto a strip of the transparent film ([7.10.1.4](#)) on a glass microscope slide. Fill the mould with the test material, prepared in accordance with the manufacturer's instructions, taking care to exclude air bubbles. Slightly overfill the mould and put a second strip of the transparent film on top followed by the second microscope slide. Press the mould and strips of film between the glass slides ([7.10.1.2](#)) to displace excess material. Place the mould onto the filter paper ([7.10.1.3](#)), remove the microscope slide covering the upper strip of film and gently place the exit window of the external energy source ([7.10.1.5](#)) against the strip of film so that the centre of the window is aligned with the centre of the specimen. Irradiate the material for the time recommended by the manufacturer to achieve a depth of cure of at least 1,0 mm for opaque shade restorative materials or 1,5 mm for all other materials.

Class 2 Group 2 materials shall be tested after exposure to irradiation from the primary source and not after processing in a curing oven.

**NOTE** The test is intended to demonstrate the conversion of monomer to polymer at the modelling stage that enables the material to be transferred from the die to the curing oven.

Immediately after completion of irradiation remove the specimen from the mould and remove the uncured material with the plastics spatula (7.10.1.7). Measure the height of the cylinder of cured material with the micrometer (7.10.1.6) to an accuracy of 0,1 mm and divide the value by two.

Record this value as the depth of cure.

Repeat the test twice.

### 7.10.3 Treatment of results

If all three values for opaque shade restorative materials are no less than 1,0 mm, and for all other materials no less than 1,5 mm, the material is deemed to have conformed to the first requirement of 5.2.8.

In order to conform to the second requirement of 5.2.8, all three values shall be no more than 0,5 mm below the value stated by the manufacturer.

## 7.11 Flexural strength

### 7.11.1 Apparatus

**7.11.1.1 Mould**, e.g. stainless steel, for the preparation of a test specimen  $(25 \pm 2)$  mm  $\times$   $(2,0 \pm 0,1)$  mm  $\times$   $(2,0 \pm 0,1)$  mm. A mould release agent (see 7.10.1.1) may be used. A suitable mould is illustrated in Figure 6. See also 7.4, paragraph 4, for the preparation of metal affinity materials.

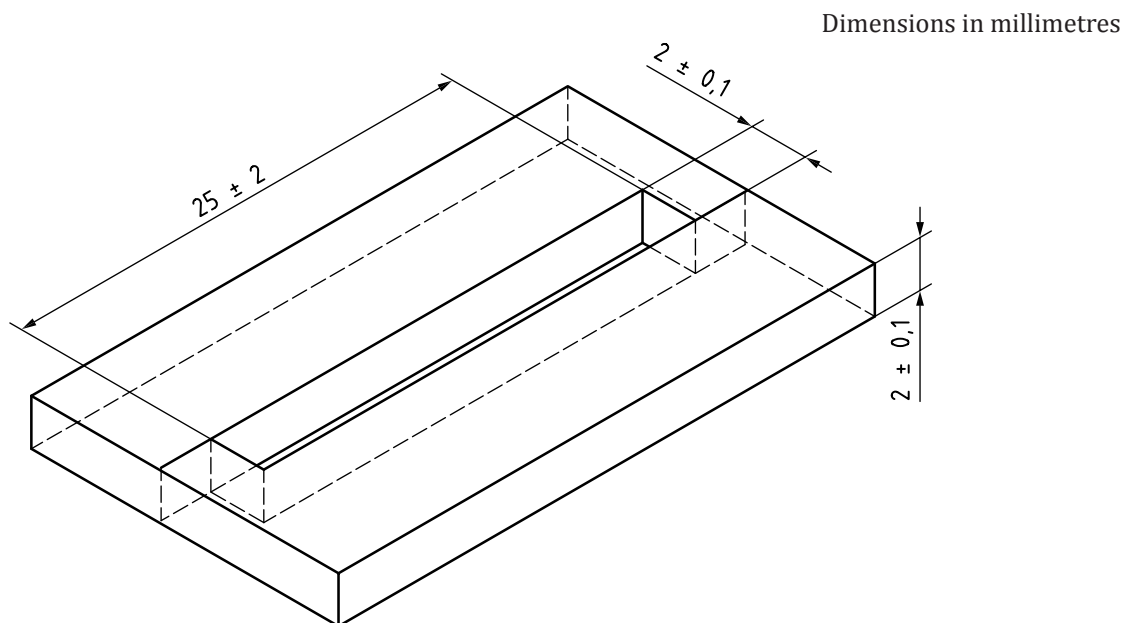

Figure 6 — Mould for preparation of flexural strength test specimens (see 7.11)

**7.11.1.2 Two metal plates**, each of sufficient area to cover the mould. For Class 2 and Class 3 materials, a glass microscope slide for use during polymerization.

**7.11.1.3 Small screw clamp** capable of exerting pressure on the metal plates during specimen preparation.

The results from this test are extremely sensitive to errors in specimen preparation, such as discontinuities or air inclusions which may be more common when preparing highly viscous materials that are particularly difficult to insert into the mould. If difficulty is experienced in preparing

satisfactory specimens for this type of material, it is recommended that the clamp should be replaced by a press, capable of applying a load of 1 000 kg to the metal plates during specimen preparation.

**7.11.1.4 Film**, transparent to the activating radiation,  $(50 \pm 30)$   $\mu\text{m}$  thick, e.g. polyester.

**7.11.1.5 White filter paper**

**7.11.1.6 Water bath** capable of being maintained at  $(37 \pm 1)$  °C.

**7.11.1.7 External energy source(s)** (for Class 2 and Class 3 materials) as recommended by the manufacturer for use with the test material (see [Table 4](#), item 20).

**7.11.1.8 Micrometer**, accurate to at least 0,005 mm.

**7.11.1.9 Mechanical testing device**, appropriately calibrated, to provide a constant cross-head speed of  $(0,75 \pm 0,25)$  mm/min or a rate of loading of  $(50 \pm 16)$  N/min.

The flexural strength test apparatus consists essentially of two rods (2 mm in diameter), mounted parallel with  $(20 \pm 0,1)$  mm between centres, and a third rod (2 mm in diameter) centred between, and parallel to, the other two, so that the three rods in combination can be used to give a three-point loading to the specimen.

## 7.11.2 Preparation of test specimens

### 7.11.2.1 Class 1 materials

Cover one of the metal plates ([7.11.1.2](#)) with the filter paper ([7.11.1.5](#)) followed by the film ([7.11.1.4](#)), and position the mould ([7.11.1.1](#)) upon it. Prepare the material in accordance with the manufacturer's instructions and immediately place it as evenly as possible without bubbles or voids into the mould with a slight excess. Place a second piece of film onto the material in the mould and cover this with the second metal plate.

Apply pressure to displace the excess material by means of the clamp ([7.11.1.3](#)) for 1 min. After the manufacturer's recommended curing time place the assembly in the water bath ([7.11.1.6](#)), maintained at  $(37 \pm 1)$  °C. After 60 min from the start of mixing, separate the mould and remove the specimen carefully. Inspect the specimen visually for any bubbles, voids or other defects. If there are any irregularities, the specimen shall be discarded and a new one made. Remove any flash by gently abrading it with 320 grit abrasive paper. Store the specimen in water ([7.1](#)) at  $(37 \pm 1)$  °C until the start of testing (see [7.11.3](#)).

Prepare five specimens.

### 7.11.2.2 Class 2 and Class 3 materials

Prepare the material in accordance with the manufacturer's instructions and fill the mould with the material, as described in [7.11.2.1](#). For Class 2 Group 1 and Class 3 materials, replace one of the metal plates with a glass slide ([7.11.1.2](#)), and place the exit window of the external energy source ([7.11.1.7](#)) at the centre of the specimen and against the glass plate. Irradiate that section of the specimen for the recommended exposure time. Move the exit window to the section next to the centre overlapping the previous section by half the diameter of the exit window and irradiate for the appropriate time. Then irradiate the section on the other side of the centre in the same way. Continue this procedure until the entire length of the specimen has been irradiated for the recommended exposure time. Repeat the irradiation procedure on the other side of the specimen. (See [Figure 7](#).) Place the assembly in the water bath maintained at  $(37 \pm 1)$  °C for 15 min. Then remove the specimen from the mould and carefully remove any flash by gently abrading it with 320 grit abrasive paper. Store in water ([7.1](#)) at  $(37 \pm 1)$  °C until the start of testing (see [7.11.3](#)).

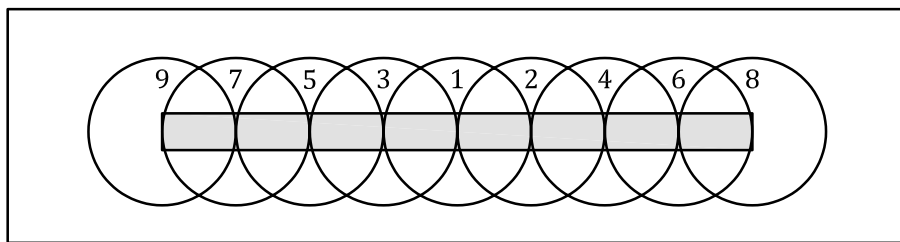

NOTE In the example, the diameter of the irradiation window of the external energy source is 7 mm.

**Figure 7 — Schematic diagram of overlapping irradiation zones for the preparation of the flexural strength specimens**

For Class 2 Group 2 materials, follow the manufacturer's instructions regarding the use of the external energy source, (see [Table 4](#), item 20). If the instructions require a preliminary exposure to blue light prior to the placement of the specimen into the external energy apparatus, perform this exposure in accordance with the procedure specified in the paragraph above (Group 1 materials). Remove the specimen from the mould and carefully remove any flash by gently abrading it with 320 grit abrasive paper. Place it directly in the external energy apparatus. After curing, remove the specimen from the apparatus and store in water ([7.1](#)) at  $(37 \pm 1) ^\circ\text{C}$  until the start of testing (see [7.11.3](#)).

If no preconditioning is required prior to the insertion of the material in the apparatus, the material and the mould shall be placed in the apparatus for curing. After curing, remove the specimen from the mould and carefully remove any flash by gently abrading it with 320 grit abrasive paper. Store in water ([7.1](#)) at  $(37 \pm 1) ^\circ\text{C}$  until the start of testing, (see [7.11.3](#)).

Prepare five specimens.

### 7.11.3 Procedure

Measure the dimensions of the specimen at its centre to an accuracy of 0,01 mm. Transfer the specimen to the flexural strength testing apparatus (see [7.11.1.9](#)).

At 24 h after the start of mixing (Class 1 materials), or irradiation (Class 2 and Class 3 materials) apply a load to the specimen at a cross-head speed of  $(0,75 \pm 0,25) \text{ mm/min}$  or at a rate of loading  $(50 \pm 16) \text{ N/min}$  until either the specimen reaches the yield point or, if there is no yield point, fractures.

Record the maximum load exerted on the specimen either at the yield point or at the point of fracture.

Repeat the test on the four other specimens.

### 7.11.4 Treatment of results

Calculate the flexural strength,  $\sigma$ , in megapascals, from the following formula:

$$\sigma = \frac{3Fl}{2bh^2}$$

where

- $F$  is the maximum load, in newtons, exerted on the specimen;
- $l$  is the distance, in millimetres, between the supports, accurate to 0,01 mm;
- $b$  is the width, in millimetres, at the centre of the specimen measured immediately prior to testing;
- $h$  is the height, in millimetres, at the centre of the specimen measured immediately prior to testing.



Report as follows:

- a) If at least four of the results are equal to or greater than the limit specified in [Table 1](#), the material is deemed to have conform to the requirement of [5.2.9](#).
- b) If three or more of the results are less than the limit specified in [Table 1](#), the material is deemed to have failed absolutely.
- c) If only three of the results are equal to or greater than the limit specified in [Table 1](#), repeat the whole test. All five specimens of the second series shall be equal to or greater than the limit specified in [Table 1](#) for the material to be deemed to conform to the requirement of [5.2.9](#).

## 7.12 Water sorption and solubility

### 7.12.1 Apparatus

**7.12.1.1 Mould** of internal dimensions ( $15,0 \pm 0,1$ ) mm in diameter and ( $1,0 \pm 0,1$ ) mm deep, for the preparation of specimen discs.

A split ring or “washer” mould is suitable. See also [7.4](#), paragraph 4, for the preparation of metal affinity materials.

A mould release agent which does not interfere with the setting reaction, for example a 3 % solution of polyvinyl ether wax in hexane, may be used to facilitate removal of the specimen.

**7.12.1.2 Film** transparent to the activating radiation, e.g. polyester, ( $50 \pm 30$ )  $\mu\text{m}$  thick.

**7.12.1.3 Two metal plates** of sufficient area to cover the mould.

For Class 2 and Class 3 materials, a glass microscope slide for use during polymerisation.

**7.12.1.4 Two desiccators**, containing silica gel freshly dried according to the manufacturer’s instructions for the silica gel. Replace the silica gel with freshly dried gel after each weighing sequence.

**7.12.1.5 External energy source(s)** (for Class 2 and Class 3 materials), as recommended by the manufacturer for use with the test material (see [Table 4](#), item 20).

**7.12.1.6 Oven** capable of being maintained at ( $37 \pm 2$ ) °C.

**7.12.1.7 Analytical balance** accurate to 0,05 mg in the measuring range required in the test.

**7.12.1.8 Micrometer**, accurate to at least 0,005 mm.

### 7.12.1.9 Clamps

#### 7.12.1.10 Plastics tweezers

To avoid contamination of the specimens, they shall be handled at all times with the tweezers.

**7.12.1.11 Hand dust-blower** or **source of oil-free compressed air** with micro-jet nozzle.

**7.12.1.12 Timer** accurate to 1 s.

## 7.12.2 Preparation of test specimens

### 7.12.2.1 Class 1 materials

Place a piece of film (7.12.1.2) on one of the metal plates (7.12.1.3) and place the mould (7.12.1.1) on it. Slightly overfill the mould with the material, prepared in accordance with the manufacturer's instructions. Place a second piece of film onto the material in the mould and cover this with the second metal plate, thus displacing excess material.

Clamp the mould together and transfer the assembly immediately to the oven (7.12.1.6) maintained at  $(37 \pm 2)$  °C. After 60 min, timed from the start of mixing, remove the specimen from the mould, taking care to avoid surface contamination. Finish the periphery of the specimen to remove flash and irregularities. Hold the periphery of the specimen against No. 1 000 grit abrasive paper on a non-rotating grinding table and rotate the specimen so that the periphery is abraded. Visually inspect the specimen periphery to ensure it is smooth. Blow debris away with the compressed air jet or dust blower (7.12.1.11). The diameter of the finished specimen shall be no less than 14,8 mm.

Prepare five specimen discs in this way.

### 7.12.2.2 Class 2 and Class 3 materials

Prepare the material in accordance with the manufacturer's instructions and fill the mould with the material as described in 7.12.2.1 and, having displaced excess material, remove the metal plate, leaving the film in place, and replace it with the glass plate. For Class 2, Group 1 and Class 3 materials place the exit window of the external energy source (see 7.12.1.5) against the glass plate (see 7.12.1.3). Irradiate that section of the specimen for the recommended exposure time. Move the exit window and irradiate a section of the specimen overlapping the previous section of the specimen. Continue this procedure until the whole specimen has been irradiated for the recommended exposure time. Turn the mould over, remove the other metal plate and replace it with a glass slide. Irradiate the second side of the specimen in the same way as the first side.

A template is required to perform this overlapping irradiation efficiently; the exact number of exposures is dependent on the diameter of the exit window. Figure 8 shows an example of such a template. The external energy source tip diameter is 7 mm.

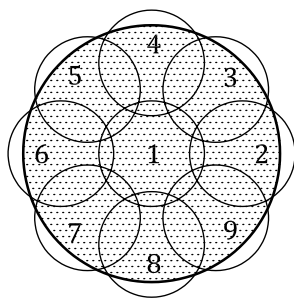

**Figure 8 — Schematic diagram of overlapping irradiation zones for the preparation of the water sorption specimens, (see 7.12)**

Immediately after irradiation, transfer the mould to the oven (7.12.1.6) maintained at  $(37 \pm 2)$  °C. At 15 min after the commencement of irradiation, remove the specimen from the mould and finish the periphery as described in 7.12.2.1.

Prepare five specimen discs in this way.

For Class 2, Group 2 materials, follow the manufacturer's instructions regarding the use of the external energy source(s), (see Table 4, item 20). If the instructions require a preliminary exposure to blue light prior to the placement of the specimen into the external energy apparatus, perform this in accordance with the procedure specified in the paragraph above, remove the specimen from the mould and place it

directly in the external energy apparatus. After curing, remove the specimen from the apparatus and finish the periphery as described in [7.12.2.1](#).

If no preconditioning is required prior to the insertion of the material in the apparatus, the material shall be left in the mould for curing. After curing, remove the specimen from the mould and finish the periphery as described in [7.12.2.1](#).

Prepare five specimens.

### 7.12.3 Procedure

**7.12.3.1** Transfer the specimens to one of the two desiccators ([7.12.1.4](#)) maintained at  $(37 \pm 2)$  °C. After 22 h remove the specimens, store them in the second desiccator maintained at  $(23 \pm 1)$  °C for 2 h and then weigh them to an accuracy of 0,1 mg. Repeat this cycle until a constant mass,  $m_1$ , is obtained, i.e. until the mass loss of each specimen is no more than 0,1 mg in any 24 h period.

Approximately 2-3 weeks may be necessary to achieve constant mass.

**7.12.3.2** After final drying, make two measurements to an accuracy of 0,01 mm of the diameter at right angles to each other and calculate the mean diameter. Measure the thickness of the specimen at the centre of the specimen and at four equally spaced points on the circumference to an accuracy of 0,01 mm. Calculate the area, in square millimetres, from the mean diameter and then, using the mean thickness, calculate the volume,  $V$ , in cubic millimetres.

**7.12.3.3** Immerse the specimens in water ([7.1](#)) at  $(37 \pm 2)$  °C and place in the oven ([7.12.1.6](#)) maintained at  $(37 \pm 2)$  °C for 7 days in such a way that they are vertical and have a minimum of 3 mm separation between specimens. A rack is needed to do this efficiently. The volume of water for immersion of the specimens shall be at least 10 ml per specimen. After 7 days, remove the specimens, wash with water ([7.1](#)), blot away surface water until free from visible moisture, wave in the air for 15 s, and weigh 1 min after removal from the water. Record this mass as  $m_2$ .

**7.12.3.4** After this weighing, recondition the specimens to constant mass in the desiccators using the cycle described in [7.12.3.1](#). Record the constant mass as  $m_3$ .

### 7.12.4 Treatment of results

#### 7.12.4.1 Water sorption

Calculate the values for water sorption,  $W_{sp}$ , in micrograms per cubic millimetre, for each of the five specimens using the following formula:

$$W_{sp} = \frac{m_2 - m_3}{V}$$

where

$m_2$  is the mass of the specimen, in micrograms, after immersion in water for 7 days (see [7.12.3.1](#));

$m_3$  is the mass of the reconditioned specimen, in micrograms (see [7.12.3.4](#));

$V$  is the volume of the specimen, in cubic millimetres (see [7.12.3.2](#)).

#### 7.12.4.2 Treatment of water sorption test results

Report the water sorption results as follows:

- a) If at least four of the values obtained are equal to or less than  $40 \mu\text{g}/\text{mm}^3$ , the material is deemed to have conformed to the first requirement of [5.2.10](#).
- b) If two or fewer of the values obtained are equal to or less than  $40 \mu\text{g}/\text{mm}^3$ , the material is deemed to have failed.
- c) If three of the values are equal to or less than  $40 \mu\text{g}/\text{mm}^3$ , repeat the whole test. If all the values are equal to or less than  $40 \mu\text{g}/\text{mm}^3$  on the second occasion, the material is deemed to have passed the whole test.

#### 7.12.4.3 Solubility

Calculate the values for solubility,  $W_{\text{sl}}$ , in micrograms per cubic millimetre, for each of the five specimens using the following Formula:

$$W_{\text{sl}} = \frac{m_1 - m_3}{V}$$

where

- $m_1$  is the conditioned mass, in micrograms, prior to immersion in water (see [7.12.3.1](#));
- $m_3$  is the mass of the reconditioned specimen, in micrograms (see [7.12.3.4](#));
- $V$  is the volume of the specimen, in cubic millimetres (see [7.12.3.2](#)).

#### 7.12.4.4 Treatment of solubility test results

Report the solubility results as follows:

- a) If at least four of the values obtained are equal to or less than  $7,5 \mu\text{g}/\text{mm}^3$  the material is deemed to have conformed to the second requirement of [5.2.10](#).
- b) If two or less of the values obtained are equal to or less than  $7,5 \mu\text{g}/\text{mm}^3$  the material is deemed to have failed.
- c) If three of the values are equal to or less than  $7,5 \mu\text{g}/\text{mm}^3$  repeat the whole test. If, on the second occasion, at least four of the values are equal to or less than  $7,5 \mu\text{g}/\text{mm}^3$ , the material is deemed to have passed the whole test.

NOTE The test for solubility is technically demanding and it is for this reason that the requirement following a second series of tests is lower than for other tests in this document. Solubility is considered to be a manifestation of material quality.

### 7.13 Shade and colour stability after irradiation and water sorption

#### 7.13.1 General

The test is intended to demonstrate the colour stability of a material after xenon lamp irradiation and after water sorption by comparing an irradiated specimen and a non-irradiated, water immersed specimen with a dry reference specimen. Carry out the test in accordance with ISO 7491.

#### 7.13.2 Apparatus

7.13.2.1 Oven capable of being maintained at  $(37 \pm 2) \text{ }^\circ\text{C}$ .

**7.13.2.2 Radiation source, water bath and other apparatus**, as described in ISO 7491.

### 7.13.3 Preparation of test specimens

Prepare three disc specimens as described in [7.12.2.1](#) for Class 1 materials or [7.12.2.2](#) for Class 2 and Class 3 materials but omitting the precise finishing of the periphery.

### 7.13.4 Procedure

- **Specimen 1:** After removal from the mould, store one specimen in the dark, dry in the oven ([7.13.2.1](#)) at  $(37 \pm 2)$  °C for 7 days; this is the reference specimen.
- **Specimen 2:** After removal from the mould, store one specimen in the dark in the oven ([7.13.2.1](#)) in water ([7.1](#)) at  $(37 \pm 2)$  °C for 7 days; this specimen will demonstrate any deterioration in colour due to water sorption alone.
- **Specimen 3:** After removal from the mould, store one specimen in the dark, dry in the oven ([7.13.2.1](#)) at  $(37 \pm 2)$  °C for  $(24 \pm 2)$  h. After this time, remove the specimen from the oven and blank off half of it with aluminium or tin foil. Place this specimen in the radiation chamber ([7.13.2.2](#)), immerse it in water at  $(37 \pm 5)$  °C and expose it to the radiation for 24 h. Ensure that the water level is  $(10 \pm 3)$  mm above the specimen. After exposure, remove the metal foil, and transfer the specimen back to the oven at  $(37 \pm 2)$  °C and store it in the dark, dry for 5 days.

### 7.13.5 Colour comparison for shade

After 7 days, remove wet specimen 2 from the oven, blot it dry with absorbent paper and compare its colour with the manufacturer's nominated shade guide ([Table 4](#), item 25). Carry out the colour comparison in accordance with [5.3](#) and ISO 7491.

### 7.13.6 Colour comparison for colour stability

After 7 days, remove specimens 1 and 3 from the oven. Compare the colour of wet specimen 2 (see [7.13.5](#)) with the reference specimen 1.

Compare the colour of both halves of specimen 3 with each other and with the reference specimen 1.

Carry out all the colour comparisons in accordance with [5.4](#) and ISO 7491.

## 7.14 Radio-opacity

### 7.14.1 Perform the test in accordance with ISO 13116

### 7.14.2 Preparation of test specimens

Prepare one disc specimen as described in [7.12.2.1](#) for class 1 materials or [7.12.2.2](#) for Class 2 and Class 3 materials omitting the precise finishing of the periphery. This method will produce specimens with a thickness in the range  $(1,0 \pm 0,1)$  mm.

### 7.14.3 Treatment of results

Treat the results in accordance with Clause 8 of ISO 13116:2014 and determine the radio-opacity (aluminium equivalent) value.

If this value is equal to or greater than 1 mm the material is deemed to have conformed to the first requirement of [5.5](#).

If the manufacturer has claimed a specific value for radio-opacity (see [Table 4](#), items 16 and 28) then the aluminium equivalent determined above shall be no more than 0,5 mm below the value claimed by the manufacturer.

## 8 Packaging, marking, instructions and information to be supplied by the manufacturer

### 8.1 Packaging

The materials shall be supplied in containers or capsules that afford adequate protection and have no adverse effect on the quality of the contents. An outer pack may also be used to present the containers or capsules as a single unit that provides protection for them.

### 8.2 Marking and instructions for use

Information shall be clearly marked on the outermost packaging or containers (for multi-dose packs or capsules), as appropriate, and as indicated in [Table 4](#).

Instructions shall accompany each package of the material or be otherwise available electronically and shall include the information appropriate to the material as indicated in [Table 4](#).

Information additional to that specified in [Table 4](#) may be supplied at the discretion of the manufacturer, or as required by regulation.

NOTE [Table 4](#) contains several optional items and serves as a guide to the manufacturer as to the type of information which might be useful to dentists.

**Table 4 — Requirements for marking and instructions for use (1 of 3)**

Items of marking and instructions for use		Outermost packaging see <a href="#">3.4</a>	Outer pack of capsules see <a href="#">3.3</a>	Capsule (single-dose), syringes or bottles	Manufacturer's instructions
1	The trade name of the product or a means of identifying it.	M	M <sub>a</sub>	M	M
2	The identification or name of the manufacturer.	M	M <sub>b</sub>	OPT	M
3	The address of the manufacturer or the agent responsible for the country of sale.	M	OPT	NA	M
4	Manufacturer's URL.	OPT	OPT	NA	OPT
5	The recommended conditions of storage.	M	OPT	NA	M
6	Batch identification consisting of a serial number or a combination of letters and numbers that refers to the manufacturer's records for that particular batch of material.	M	M <sub>a</sub>	M	NA
<p><b>Key</b> For combination of container/markings/instructions:</p> <p>M — mandatory;</p> <p>M<sub>a</sub> — when the marking is clearly identifiable through the outer pack, this requirement is optional;</p> <p>M<sub>b</sub> — when the marking is described on the capsule, syringe or bottle, and is identifiable clearly through the outer pack, this requirement is optional;</p> <p>OPT — informative but optional;</p> <p>NA — not applicable.</p>					

Table 4 (continued)

Items of marking and instructions for use		Outermost packaging see 3.4	Outer pack of capsules see 3.3	Capsule (single-dose), syringes or bottles	Manufacturer's instructions
7	The expiry date, expressed in accordance with ISO 8601-1:2019 and ISO 8601-2:2019, for the material if stored under the manufacturer's recommended conditions.	M	M <sub>b</sub>	OPT	NA
8	The classification of the material (see 4).	OPT	OPT	OPT	M
9	A statement indicating whether the material is chemically activated, activated by external energy or dual-cure, either intra-orally or extra-orally.	M	OPT	NA	M
10	The presence of hazardous substances in respect of such properties as toxicity, hazard, flammability or tissue irritancy, for both patient and operator, indicated by text or symbol.	OPT	OPT	NA	M
11	The legend "polymer-based dental restorative material" if the product is a restorative material or "polymer-based luting material" if the product is a luting material.	M	OPT	NA	NA
12	The net mass in each container and capsule.	M	M <sub>b</sub>	OPT	OPT
13	The shade or description of the material that can be related to the manufacturer's nominated shade guide, if the material is supplied in a range of pre-coloured shades.	OPT	M <sub>a</sub>	M	OPT
14	In the case of a luting material, a statement indicating whether the manufacturer claims colour stability.	OPT	OPT	NA	M
15	In the case of restorative materials, a statement indicating whether or not the material is suitable for the restoration of occlusal surfaces.	OPT	OPT	NA	M
16	The word "radio-opaque" if the material conforms to the requirements of 5.5.	OPT	OPT	NA	M
17	The range of dimensions of inorganic filler particles and the percentage by volume of total inorganic filler.	OPT	OPT	NA	M
18	The indications for clinical use.	OPT	OPT	NA	M
<p><b>Key</b> For combination of container/markings/instructions:</p> <p>M — mandatory;</p> <p>M<sub>a</sub> — when the marking is clearly identifiable through the outer pack, this requirement is optional;</p> <p>M<sub>b</sub> — when the marking is described on the capsule, syringe or bottle, and is identifiable clearly through the outer pack, this requirement is optional;</p> <p>OPT — informative but optional;</p> <p>NA — not applicable.</p>					

Table 4 (continued)

	Items of marking and instructions for use	Outermost packaging see 3.4	Outer pack of capsules see 3.3	Capsule (single-dose), syringes or bottles	Manufacturer's instructions
19	<p>Instructions for the preparation and proportioning of components and mixing, including, if appropriate, the maximum proportion of tints and blenders that may be used without detriment to the physical properties.</p> <p>The ambient conditions under which this should be carried out may be included.</p>	NA	NA	NA	M
20	<p>The recommended external energy source(s) and exposure/processing times for all versions of Class 2 and Class 3 materials, and, in the case of Class 2 materials, the depth to which the material is cured after the recommended exposure (determined in accordance with 7.10). The information shall include the emission wavelength region(s), the irradiance of the powered polymerization activator, and the exposure time.</p> <p>For Class 2 materials a warning that polymerisation may be started by ambient lighting or the dental operating light.</p>	NA	NA	NA	M
21	<p>The working and setting times for Class 1 and Class 3 materials, and, an indication of the time when a matrix may be removed, if this differs from the setting time.</p>	NA	NA	NA	M
22	<p>Information on the use of a base or liner, if recommended, or other recommended protective measures if the material is likely to cause pulpal irritation, and information on whether any base or liner is known to be incompatible with the material e.g. eugenol containing materials.</p>	NA	NA	NA	M
23	<p>The recommended instructions for finishing.</p>	NA	NA	NA	M
24	<p>Any pharmacologically active ingredients, when present and referred to in the material claim for use.</p>	NA	NA	NA	M
<p><b>Key</b> For combination of container/marking/instructions:  M — mandatory;  M<sub>a</sub> — when the marking is clearly identifiable through the outer pack, this requirement is optional;  M<sub>b</sub> — when the marking is described on the capsule, syringe or bottle, and is identifiable clearly through the outer pack, this requirement is optional;  OPT — informative but optional;  NA — not applicable.</p>					



Table 4 (continued)

Items of marking and instructions for use		Outermost packaging see 3.4	Outer pack of capsules see 3.3	Capsule (single-dose), syringes or bottles	Manufacturer's instructions
25	In order to identify pre-coloured shades for restorative materials, the manufacturer shall supply a shade guide or nominate a commercially available shade guide for use with the material. The shade guide shall indicate the colour of the fully water-saturated material. In the case of luting materials this requirement shall only apply when colour stability is claimed.  A manufacturer may include such information when colour stability is not claimed without contravening this document.	NA	NA	NA	M
26	In the case of luting materials whether the material has a chemical affinity for metal.	NA	NA	NA	M
27	Information about the use and compatibility of the material with adhesives and bonding agents.	NA	NA	NA	M
<p><b>Key</b> For combination of container/markings/instructions:</p> <p>M — mandatory;</p> <p>M<sub>a</sub> — when the marking is clearly identifiable through the outer pack, this requirement is optional;</p> <p>M<sub>b</sub> — when the marking is described on the capsule, syringe or bottle, and is identifiable clearly through the outer pack, this requirement is optional;</p> <p>OPT — informative but optional;</p> <p>NA — not applicable.</p>					

Table 4 (continued)

Items of marking and instructions for use	Outermost packaging see 3.4	Outer pack of capsules see 3.3	Capsule (single-dose), syringes or bottles	Manufacturer's instructions
28 If radio-opacity is claimed, this shall be determined in accordance with 7.14 and the value stated in the instructions. If certain shades amongst others that are radio-opaque are not radio-opaque, this shall be stated. If the radio-opacity value of another shade or shades is more than twice the "universal" shade value, this shall be stated, and the manufacturer shall give an indication, either quantitatively or qualitatively, of the differences.  An explanation of the radio-opacity value shall be included, e.g. Aluminium has a radio-opacity equivalent to that of dentine. Thus 1 mm of material having a radio-opacity equivalent to 1 mm of aluminium has a radio-opacity equivalent to that of dentine and 2 mm of aluminium is equivalent to enamel.	NA	NA	NA	M
29 A polymerisation shrinkage value may be included at the discretion of the manufacturer. If one is included this shall have been determined using ISO 17304.	NA	NA	NA	OPT
30 Date of issue of the instructions.	NA	NA	NA	M
<b>Key</b> For combination of container/markings/instructions: M — mandatory; M <sub>a</sub> — when the marking is clearly identifiable through the outer pack, this requirement is optional; M <sub>b</sub> — when the marking is described on the capsule, syringe or bottle, and is identifiable clearly through the outer pack, this requirement is optional; OPT — informative but optional; NA — not applicable.				

### 8.3 Declaration of components

The manufacturer shall provide, either in the instructions for use or by means of a Safety Data Sheet, the composition and information on components present in the material  $\geq 1$  % by mass (irrespective of hazard potential) and any ingredient that is classified as a carcinogen, mutagen or reproductive toxicant (CMR) present in the material  $\geq 0,1$  % by mass.

The list shall include a chemical name or its common abbreviation, if available, (e.g. BisGMA, HEMA, TEGDMA). The Chemical Abstracts Service registry number (CAS number) may be used.

Either the mass per cent range for each listed component or a listing in the order of mass from the highest to the lowest concentration shall be provided.

**NOTE** CMR is defined in authoritative lists, for example, by the International Agency for Research on Cancer (IARC), National Toxicology Program (NTP), American Conference of Governmental Industrial Hygienists (ACGIH), EC Annex VI CMR to Regulation (EC) 1272/2008.

The manufacturer may include additional information at their discretion.

## Bibliography

- [1] ISO 3665:2011, *Photography — Intra-oral dental radiographic film and film packets — Manufacturer specifications*
- [2] ISO 6874, *Dentistry — Polymer-based pit and fissure sealants*
- [3] ISO 7405, *Dentistry — Evaluation of biocompatibility of medical devices used in dentistry*
- [4] ISO 9680, *Dentistry — Operating lights*
- [5] ISO 10477, *Dentistry — Polymer-based crown and veneering materials*
- [6] ISO 10993-1, *Biological evaluation of medical devices — Part 1: Evaluation and testing within a risk management process*
- [7] ISO 10650, *Dentistry — Powered polymerization activators*
- [8] ISO/TS 16506, *Dentistry — Polymer-based luting materials containing adhesive components*
- [9] EUROPEAN UNION. Regulation (EC) No 1272/2008 of the European Parliament and of the Council of 16 December 2008 on classification, labelling and packaging of substances and mixtures, amending and repealing Directives 67/548/EEC and 1999/45/EC, and amending Regulation (EC) No 1907/2006 (Text with EEA relevance). Available at <https://eur-lex.europa.eu/legal-content/EN/ALL/?uri=celex:32008R1272>

**NATIONAL ANNEX A**  
*(National Foreword)*

**A-1 BIS CERTIFICATION MARKING**

The product(s) conforming to the requirements of this standard may be certified as per the conformity assessment schemes under the provisions of the *Bureau of Indian Standards*, 2016 and the Rules and Regulations framed thereunder, and the product(s) may be marked with the Standard Mark.

*(Continued from second cover)*

In this standard, the modification of IS 1070 : 1992 from ISO 3696 includes limits for three grades of water depending on their end use and its characteristics.

For the purpose of deciding whether a particular requirement of this standard is complied with, the final value, observed or calculated, expressing the result of a test shall be rounded off in accordance with IS 2 : 2022 'Rules for rounding off numerical values (*second revision*)'.

This standard also makes a reference to the BIS Certification Marking of the product. Details of which is given in National Annex A.

## Bureau of Indian Standards

BIS is a statutory institution established under the *Bureau of Indian Standards Act, 2016* to promote harmonious development of the activities of standardization, marking and quality certification of goods and attending to connected matters in the country.

### Copyright

BIS has the copyright of all its publications. No part of these publications may be reproduced in any form without the prior permission in writing of BIS. This does not preclude the free use, in the course of implementing the standard, of necessary details, such as symbols and sizes, type or grade designations. Enquiries relating to copyright be addressed to the Head (Publication & Sales), BIS.

### Review of Indian Standards

Amendments are issued to standards as the need arises on the basis of comments. Standards are also reviewed periodically; a standard along with amendments is reaffirmed when such review indicates that no changes are needed; if the review indicates that changes are needed, it is taken up for revision. Users of Indian Standards should ascertain that they are in possession of the latest amendments or edition by referring to the website-[www.bis.gov.in](http://www.bis.gov.in) or [www.standardsbis.in](http://www.standardsbis.in).

This Indian Standard has been developed from Doc No.: MHD 08 (19053).

### Amendments Issued Since Publication

Amend No.	Date of Issue	Text Affected

## BUREAU OF INDIAN STANDARDS

### Headquarters:

Manak Bhavan, 9 Bahadur Shah Zafar Marg, New Delhi 110002

Telephones: 2323 0131, 2323 3375, 2323 9402

Website: [www.bis.gov.in](http://www.bis.gov.in)

### Regional Offices:

	Telephones
Central : 601/A, Konnectus Tower -1, 6 <sup>th</sup> Floor, DMRC Building, Bhavbhuti Marg, New Delhi 110002	{ 2323 7617
Eastern : 8 <sup>th</sup> Floor, Plot No 7/7 & 7/8, CP Block, Sector V, Salt Lake, Kolkata, West Bengal 700091	{ 2367 0012 2320 9474
Northern : Plot No. 4-A, Sector 27-B, Madhya Marg, Chandigarh 160019	{ 265 9930
Southern : C.I.T. Campus, IV Cross Road, Taramani, Chennai 600113	{ 2254 1442 2254 1216
Western : Plot No. E-9, Road No.-8, MIDC, Andheri (East), Mumbai 400093	{ 2821 8093

**Branches :** AHMEDABAD. BENGALURU. BHOPAL. BHUBANESHWAR. CHANDIGARH. CHENNAI. COIMBATORE. DEHRADUN. DELHI. FARIDABAD. GHAZIABAD. GUWAHATI. HIMACHAL PRADESH. HUBLI. HYDERABAD. JAIPUR. JAMMU & KASHMIR. JAMSHEDPUR. KOCHI. KOLKATA. LUCKNOW. MADURAI. MUMBAI. NAGPUR. NOIDA. PANIPAT. PATNA. PUNE. RAIPUR. RAJKOT. SURAT. VISAKHAPATNAM.