

यांत्रिक, सामान्य अभियांत्रिकी और सजावटी  
उद्देश्यों के लिए अतप्त रूपित वेल्डेड कार्बन  
इस्पात वर्गाकार और आयताकार खोखले  
खंड — विशिष्टि

**Cold Formed Welded Carbon Steel  
Square and Rectangular Hollow  
Sections for Mechanical, General  
Engineering and Decorative  
Purposes — Specification**

ICS 77.140.75

© BIS 2024



भारतीय मानक ब्यूरो  
BUREAU OF INDIAN STANDARDS  
मानक भवन, 9 बहादुर शाह ज़फर मार्ग, नई दिल्ली - 110002  
MANAK BHAVAN, 9 BAHADUR SHAH ZAFAR MARG  
NEW DELHI - 110002  
[www.bis.gov.in](http://www.bis.gov.in) [www.standardsbis.in](http://www.standardsbis.in)

## FOREWORD

This Indian Standard was adopted by the Bureau of Indian Standards, after the draft finalized by the Steel Tubes, Pipes and Fittings Sectional Committee had been approved by the Metallurgical Engineering Division Council.

Hollow steel sections for structural use are covered under IS 4923 : 2017. A need was felt to formulate a standard on cold formed welded carbon steel square and rectangular hollow sections as a large number of these sections are used for non-structural use such as mechanical, general engineering and decorative purpose.

In formulation of this standard, assistance has been derived from the following:

- a) ISO 10799-1 : 2011 Cold-formed welded structural hollow sections of non-alloy and fine grain steels — Part 1: Technical delivery conditions; and
- b) ISO 10799-2 : 2011 Cold-formed welded structural hollow sections of non-alloy and fine grain steels — Part 2: Dimensions and sectional properties.

The composition of the Committee responsible for formulation of this standard is given in [Annex C](#).

For the purpose of deciding whether a particular requirement of this standard is complied with, the final value, observed or calculated, expressing the result of a test or analysis, shall be rounded off in accordance with IS 2 : 2022 'Rules for rounding off numerical values (*second revision*)'. The number of significant places retained in the rounded off value should be the same as that of the specified value in this standard.

*Indian Standard*

# COLD FORMED WELDED CARBON STEEL SQUARE AND RECTANGULAR HOLLOW SECTIONS FOR MECHANICAL, GENERAL ENGINEERING AND DECORATIVE PURPOSES — SPECIFICATION

## 1 SCOPE

**1.1** This standard covers cold formed square and rectangular welded hollow sections for mechanical, general engineering and decorative purposes.

**1.2** This standard does not cover cold formed welded carbon steel square and rectangular sections for structural purposes, which is covered by separate Indian Standards.

**1.3** This standard covers requirements regarding material, mechanical properties, dimensions, tolerances and surface protection for square and rectangular hollow sections.

## 2 REFERENCES

The standards listed in [Annex A](#) contain provisions, which through references in this text constitute provisions of this standard. At the time of publication, the editions indicated were valid. All standards are subject to revision and parties to agreements based on this standard are encouraged to investigate the possibility of applying the most recent edition of these standards.

## 3 TYPES AND GRADES

Types and grades of the cold formed square and rectangular hollow section for mechanical, general engineering and decorative purposes shall be based on the process of manufacture and minimum yield stress, in MPa, as given in [Table 1](#) and [Table 2](#).

**Table 1 Types and Grades of Square and  
Rectangular Hollow Section**  
([Clause 3](#) and [Annex B](#))

SI No.	Type	Grade
(1)	(2)	(3)
i)	Welded (WT) Square and rectangular sections Electric resistance welded or high frequency induction welded (ERW or HFIW) sections	YSt 160, YSt 210, YSt 240, YSt 310 and YSt 355

## 4 MATERIAL

**4.1** The ladle analysis of steel shall not show either sulphur or phosphorus more than 0.040 percent, when carried out either by the method specified in relevant parts of IS 228 or any other established instrumental/chemical method. In case of dispute the method given in relevant parts of IS 228 shall be the referee method.

**4.2** Unless specified by the purchaser, hot-rolled or cold-rolled steel sheets or strips of any suitable grade to IS 10748, IS 513, or any other equivalent specification may be used for manufacturing the square and rectangular section of above mentioned grades.

**4.3** The permissible variation in case of product analysis from the limits specified in [4.1](#) shall be as follows:

<i>Sl No.</i>	<i>Constituents</i>	<i>Percent, Max</i>
(1)	(2)	(3)
i)	Sulphur	0.005
ii)	Phosphorus	0.005

## 5 SUPPLY OF MATERIAL

General requirements relating to the supply of square and rectangular sections for mechanical, general engineering and decorative purposes shall conform to IS 1387.

## 6 WORKMANSHIP

All sections shall be free from harmful defects, reasonably smooth and free from loose scale and rust. Surface imperfections such as handling marks, light roll or die marks or shallow pits are not considered defects provided that the imperfections are removable within the specified limits of wall thickness. Welded sections shall be free of protruding metal on the outside surface of the weld seam. Unless otherwise specified, ends shall be cut square.

## 7 STRAIGHTNESS

The square and rectangular sections shall be supplied in mill straightened or finished condition. Unless otherwise tolerances are agreed to between the purchaser and the manufacturer, section shall not deviate from straightness by more than 1/200 of the length, measured at the centre of that length for mill straightened condition and 1/600 of the length at the centre of that length for finished condition.

## 8 BASIS OF CALCULATION

For the purpose of the standard, the weights are calculated on the basis that steel weighs 0.785 kg/cm<sup>2</sup> per metre run. For calculating cross-sectional area and weight per unit length, corner radii have been taken into consideration (see Annex B).

## 9 LENGTH

Unless specified by the purchaser, square and rectangular carbon steel section shall be supplied in random lengths from 4 m to 7 m. Wherever the exact length requirement is there, it will be subject to agreement between the manufacturer and the purchaser.

## 10 DIMENSIONS AND PROPERTIES

Recommendations on section size and thickness are given in Table 3 and Table 4. However, any other section size and thickness as agreed to between the manufacturer and the purchaser may be supplied. The design properties of these square and rectangular carbon steel sections are given in Table 3 and Table 4 for guidance only.

## 11 MEASUREMENT OF SIZE AND SHAPE

### 11.1 General

The sections shall be supplied either in finish straightened or mill straightened condition for

which maximum deviation from straightness shall be as given in 7.

All external dimensions shall be measured at a distance from the end of the hollow section of not less than  $B$  for square sections or  $H$  for rectangular sections, with a minimum of 100 mm.

### 11.2 Outside Dimension

For square or rectangular hollow sections, outside dimensions,  $B$  and  $H$ , shall be measured. A vernier caliper gauge or other suitable device may be used at the discretion of the manufacturer. Dimensions  $B$  and  $H$  shall be measured at a position within 5 mm (from where this requirement has extracted) from the start of the external corner profile as shown in Fig. 1. All Dimensions in millimeters. This dimension is a maximum when measuring  $B$  or  $H$  and a minimum when measuring  $T$ .

### 11.3 Thickness

The thickness,  $T$ , shall be measured at a position of not less than  $2T$  from the weld. The limiting cross-sectional positions for measuring the thickness of square and rectangular hollow sections are shown in Fig. 1.

NOTE — Thickness is normally measured within a distance of half the longer side length from the end of the section.

### 11.4 Concavity and Convexity

The concavity,  $x_1$ , or the convexity,  $x_2$ , of the sides of a square or rectangular hollow section shall be measured as shown in Fig. 2. The percentage concavity or convexity shall be calculated using the following:

$$\frac{x_1}{B} \times 100; \frac{x_2}{B} \times 100; \frac{x_1}{H} \times 100; \frac{x_2}{H} \times 100;$$

where  $B$  and  $H$  are the lengths of the sides containing the concavity,  $x_1$ , or the convexity,  $x_2$ .

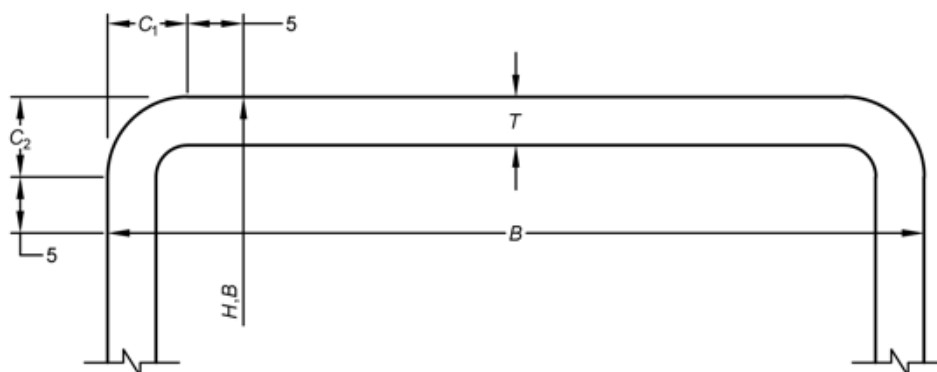

All dimensions in millimetres.

FIG.1 LIMITING CROSS-SECTIONAL POSITIONS FOR MEASURING THE DIMENSIONS  $B$ ,  $H$  AND  $T$  FOR SQUARE OR RECTANGULAR HOLLOW SECTIONS

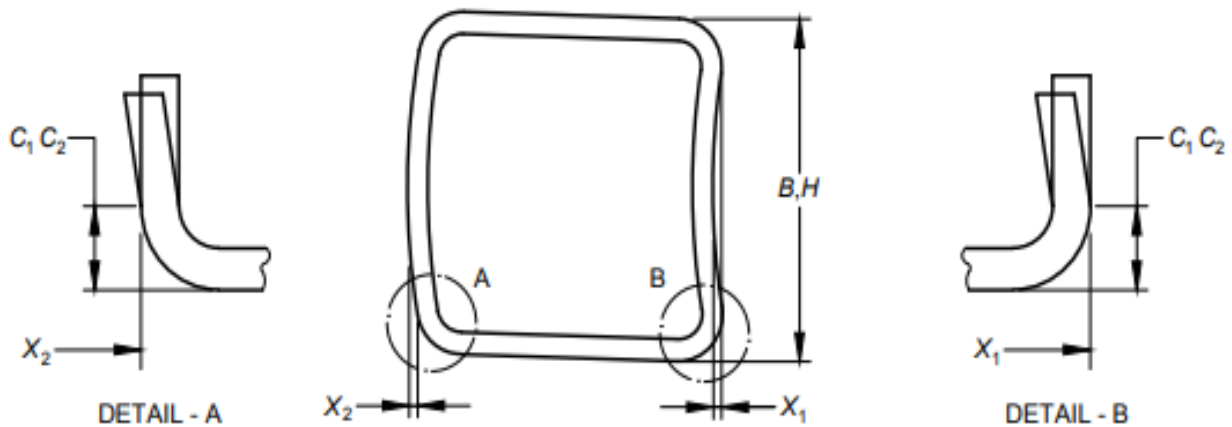

FIG. 2 MEASUREMENT OF CONCAVITY/CONVEXITY OF SQUARE OR RECTANGULAR HOLLOW SECTIONS

**11.5 Squareness of Sides**

The deviation from squareness of the sides of a square or rectangular hollow section is defined as the difference between  $90^\circ$  and  $\theta$  as shown in Fig. 3.

**11.6 External Corner Radius**

The external corner radius,  $R$  of a square or rectangular hollow section (Fig. 4) is measured by using radius gauge or other suitable device.

**11.7 Straightness and Twist**

The total twist,  $V$ , in a square or rectangular hollow section shall be determined in accordance with any

of the following methods, at the discretion of the manufacturer.

Place the hollow section on a horizontal surface with one side at one end pressed flat against the surface. At the opposite end of the hollow section, determine the difference,  $V$ , in the height of the two lower corners from a horizontal surface (see Fig. 5).

Measure  $V$  with a spirit level or scale or micrometer (screw) gauge or other suitable device. The reference length of the spirit level shall be the distance between the intersection of the flat sides and the external corner profile (see Fig. 6).  $V$  is the difference between the values,  $V_1$  (see Fig. 6), measured at each end of the section.

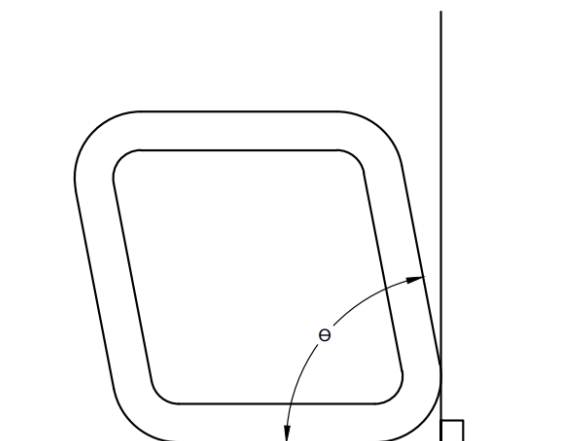

Deviation from Squareness =  $90^\circ - \theta$

FIG. 3 SQUARENESS OF SIDES OF SQUARE OR RECTANGULAR HOLLOW SECTIONS

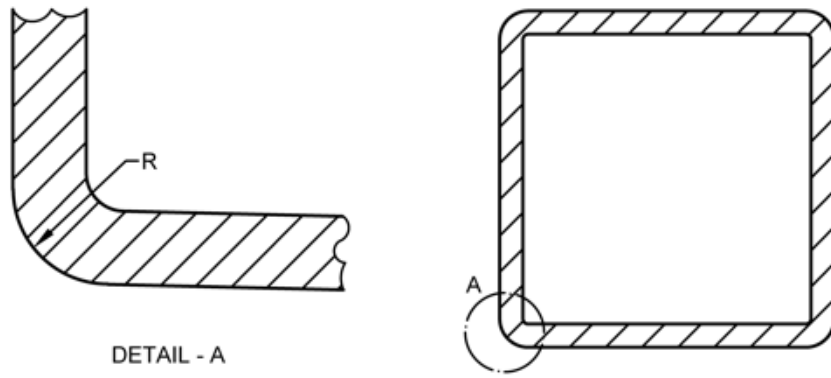

FIG. 4 EXTERNAL CORNER PROFILE OF SQUARE OR RECTANGULAR HOLLOW SECTIONS

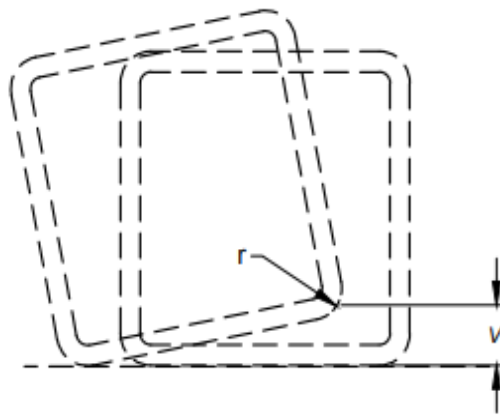
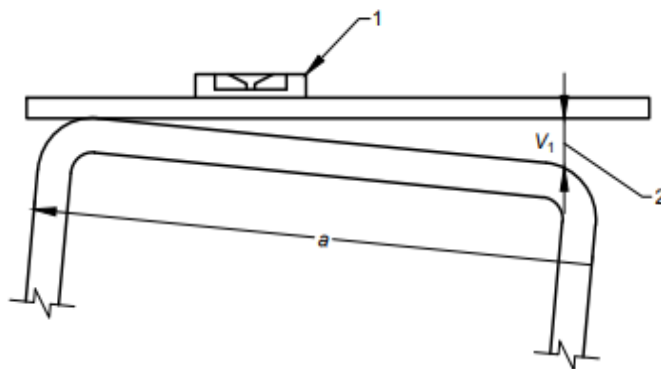

FIG. 5 TOTAL TWIST OF SQUARE OR RECTANGULAR HOLLOW SECTIONS KEY



- 1 Spirit level
  - 2 Micrometer gauge
- a  $H$  for rectangular sections,  $B$  for square sections.

FIG. 6 MEASUREMENT OF TWIST

Twist shall be measured for square and rectangular sections as given in [Fig. 1](#).

- $r_{\max}$  = maximum permitted outside corner radius in mm; and  
 $V$  = total measured twist in millimetres.

## 12 DIMENSION TOLERANCES

The square and rectangular hollow section shall conform to the following tolerances.

- a) Thickness — The tolerance on thickness excluding the weld shall be  $\pm 10$  percent;
- b) Outside dimensions — The tolerances for the outside dimensions of the square and rectangular sections shall be  $\pm 1$  percent of length of the side to be measured with a minimum of  $\pm 0.50$  mm;
- c) Squareness of corner — The squareness of the corner shall be  $90^\circ \pm 2^\circ$ ;
- d) Radii of corners — The radii of corners shall not be more than  $3 t$  where  $t$  is the thickness of section;
- e) Exact length — The tolerances on the exact length shall not be more than  $+ 6$  mm or as agreed between the manufacturer and purchaser;
- f) Random length — Square and Rectangular carbon steel section shall be supplied in random lengths from 4 m to 7 m. Whereas, a stringent tolerance may be agreed between the manufacturer and the purchaser;
- g) Concavity/convexity — The tolerance on concavity/convexity shall not be more than 1 percent of the size;
- h) Twist — 2 mm plus 0.5 mm per meter length; and
- j) Weight — The tolerance on weight shall be within  $\pm 10$  percent.

## 13 SURFACE PROTECTION

**13.1** Unless otherwise specified square and rectangular section shall be supplied uncoated or with manufacturer's standard mill protective coating.

**13.2** When square and rectangular section are to be hot dip galvanized, they shall first be thoroughly descaled and then dipped in a bath of molten zinc at a temperature suitable to produce a complete and uniformly adherent coating of zinc. The zinc used for coating shall conform to IS 209 or IS 13229. The galvanizing shall be capable of passing the test specified in IS 2633. Specific requirement for galvanizing and mass of coating shall be subject to mutual agreement between the purchaser and the manufacturer or as per the manufacturer's standard.

Pre galvanized sheet or strip may be used for manufacturing hollow sections. In case of pre galvanized sheet or strip, zinc coating shall confirm the requirements of coatings specified in IS 277 including the coating of weld portion. The method for coating of weld section shall be subject to mutual agreement between the purchaser and the manufacturer.

## 14 TESTING

**14.1** The manufacturer shall carry out the specified tests applicable to square and rectangular carbon steel sections and shall, if required by the purchaser, supply a certificate stating that hollow sections comply with the specified requirements. When the purchaser desires such certificate, this shall be stated in the enquiry and order.

**14.2** When the purchaser requires additional tests related to his order, such tests shall be subject to agreement between the purchaser and the manufacturer.

## 15 TENSILE TEST

**15.1** Tensile test shall be carried out in accordance with IS 1608 on one of the following at the manufacturers' option:

- a) A length cut from the end of the selected section, (the ends being plugged for grips or flattened where necessary); and
- b) A longitudinal strip cut from the section and tested. The test piece should be cut from the side which does not contain weld.

**15.2** When tested in accordance with IS 1608, the tensile properties shall be as shown in [Table 2](#).

**Table 2 Tensile Properties**  
(Clauses 3, 15.2 and Annex B)

Sl No.	Grade Designation	Yield Strength, Min, MPa	Tensile Strength, Min, MPa	Elongation Percent, Min On GL 5.65 $\sqrt{S_0}$
(1)	(2)	(3)	(4)	(5)
i)	YSt 160	160	310	15
ii)	YSt 210	210	330	12
iii)	YSt 240	240	410	10
iv)	YSt 310	310	450	8
v)	YSt 355	355	490	8

where

$S_0$  = original cross-sectional area;

GL = gauge length in mm; and

1 MPa = 0.102 0 kgf/mm<sup>2</sup>.

## 16 RETESTS

**16.1** Should any one of the test pieces selected fail to pass the test specified, two further samples shall be selected for testing in respect of each failure. Should the test pieces from both these additional samples pass, the material shall be deemed to comply with the requirements of the test. Should the test pieces from either of these additional samples fail, the material represented by the test samples shall be deemed as not complying with this standard.

## 17 SAMPLING FOR SECTIONS

**17.1** Lot for purpose of drawing samples all sections bearing same designation and manufactured under a single process shall be grouped together to constitute a lot. Each lot shall be sampled separately and assessed for conformity to this standard.

### 17.2 Sampling and Criterion for Conformity

Unless otherwise agreed to between the manufacturer and the purchaser the procedure for

sampling of sections for various tests and criteria for conformity, one test per 1 000 nos. to be done.

## 18 MARKING

**18.1** Manufacturer name/logo/trade-mark shall be embossed or marked on each hollow section. Each section shall have grade and size designation suitably marked on it. Alternatively, a label containing the particulars may be attached to a bundle of sections.

**18.1.1** Other particulars required by the purchaser may be suitably-marked as mutually agreed.

### 18.2 BIS Certification Marking

The product(s) conforming to the requirements of this standard may be certified as per the conformity assessment schemes under the provisions of the *Bureau of Indian Standards Act, 2016* and the Rules and Regulations framed thereunder, and the products may be marked with the Standard Mark.



**Table 3 Dimension and Properties of Square Welded Carbon Steel Section***(Clause 10)*

SI No.	Size (Depth × Width)	Thickness	Weight	Area of Section	Moment of Inertia	Radius of Gyration	Elastic Modulus	Plastic Modulus
	mm	mm	kg/m	cm <sup>2</sup>	cm <sup>4</sup>	cm	cm <sup>3</sup>	cm <sup>3</sup>
(1)	(2)	(3)	(4)	(5)	(6)	(7)	(8)	(9)
i)	20 × 20	0.9	0.52	0.67	0.40	0.77	0.40	0.47
ii)	20 × 20	1.2	0.68	0.87	0.50	0.76	0.50	0.60
iii)	20 × 20	1.4	0.78	0.99	0.56	0.75	0.56	0.68
iv)	20 × 20	1.6	0.87	1.11	0.61	0.74	0.61	0.75
v)	20 × 20	1.8	0.96	1.23	0.65	0.73	0.65	0.82
vi)	20 × 20	1.9	1.01	1.28	0.67	0.72	0.67	0.85
vii)	25 × 25	0.9	0.66	0.85	0.81	0.98	0.65	0.76
viii)	25 × 25	1.2	0.87	1.11	1.03	0.96	0.82	0.97
ix)	25 × 25	1.4	1.00	1.27	1.16	0.95	0.92	1.11
x)	25 × 25	1.6	1.12	1.43	1.28	0.94	1.02	1.24
xi)	25 × 25	1.8	1.25	1.59	1.38	0.93	1.11	1.35
xii)	25 × 25	1.9	1.31	1.66	1.43	0.93	1.15	1.41
xiii)	30 × 30	1.2	1.06	1.35	1.83	1.17	1.22	1.44
xiv)	30 × 30	1.4	1.22	1.55	2.08	1.16	1.39	1.64
xv)	30 × 30	1.6	1.37	1.75	2.31	1.15	1.54	1.84
xvi)	30 × 30	1.8	1.53	1.95	2.52	1.14	1.68	2.03
xvii)	30 × 30	1.9	1.60	2.04	2.62	1.13	1.75	2.12
xviii)	32 × 32	1.2	1.13	1.44	2.25	1.25	1.41	1.65
xix)	32 × 32	1.4	1.31	1.66	2.55	1.24	1.60	1.89
xx)	32 × 32	1.6	1.48	1.88	2.84	1.23	1.78	2.12
xxi)	32 × 32	1.8	1.64	2.09	3.11	1.22	1.95	2.33
xxii)	32 × 32	1.9	1.72	2.19	3.24	1.22	2.03	2.44
xxiii)	35 × 35	1.2	1.24	1.59	2.98	1.37	1.70	1.99
xxiv)	35 × 35	1.4	1.44	1.83	3.40	1.36	1.94	2.29
xxv)	35 × 35	1.6	1.63	2.07	3.79	1.35	2.16	2.57
xxvi)	35 × 35	1.8	1.81	2.31	4.16	1.34	2.38	2.84
xxvii)	35 × 35	1.9	1.90	2.42	4.34	1.34	2.48	2.97
xxviii)	38 × 38	1.2	1.36	1.73	3.86	1.49	2.03	2.37
xxix)	38 × 38	1.4	1.57	2.00	4.41	1.48	2.32	2.72
xxx)	38 × 38	1.6	1.78	2.26	4.92	1.47	2.59	3.06
xxxi)	38 × 38	1.8	1.98	2.52	5.42	1.47	2.85	3.39
xxxii)	38 × 38	1.9	2.08	2.65	5.65	1.46	2.97	3.54
xxxiii)	40 × 40	1.2	1.43	1.83	4.53	1.58	2.27	2.64

Table 3 (Continued)

SI No.	Size (Depth × Width)	Thickness	Weight	Area of Section	Moment of Inertia	Radius of Gyration	Elastic Modulus	Plastic Modulus
	mm	mm	kg/m	cm <sup>2</sup>	cm <sup>4</sup>	cm	cm <sup>3</sup>	cm <sup>3</sup>
(1)	(2)	(3)	(4)	(5)	(6)	(7)	(8)	(9)
xxxiv)	40 × 40	1.4	1.66	2.11	5.18	1.57	2.59	3.03
xxxv)	40 × 40	1.6	1.88	2.39	5.79	1.56	2.90	3.41
xxxvi)	40 × 40	1.8	2.09	2.67	6.38	1.55	3.19	3.78
xxxvii)	40 × 40	1.9	2.20	2.80	6.66	1.54	3.33	3.96
xxxviii)	45 × 45	1.2	1.62	2.07	6.54	1.78	2.91	3.37
xxxix)	45 × 45	1.4	1.88	2.39	7.49	1.77	3.33	3.88
xl)	45 × 45	1.6	2.13	2.71	8.41	1.76	3.74	4.38
xli)	45 × 45	1.8	2.38	3.03	9.28	1.75	4.13	4.86
xlvi)	45 × 45	1.9	2.50	3.18	9.70	1.75	4.31	5.09
xlvi)	49.5 × 49.5	1.2	1.79	2.28	8.80	1.96	3.55	4.11
xlvii)	49.5 × 49.5	1.4	2.07	2.64	10.09	1.95	4.08	4.74
xlviii)	49.5 × 49.5	1.6	2.35	3.00	11.34	1.94	4.58	5.35
xlix)	49.5 × 49.5	1.8	2.63	3.35	12.5	1.93	5.07	5.94
l)	49.5 × 49.5	1.9	2.77	3.52	13.1	1.93	5.30	6.23
li)	50 × 50	1.2	1.81	2.31	9.07	1.98	3.63	4.20
lii)	50 × 50	1.4	2.10	2.67	10.41	1.97	4.17	4.84
liii)	50 × 50	1.6	2.38	3.03	11.70	1.96	4.68	5.46
liiii)	50 × 50	1.8	2.66	3.39	12.9	1.96	5.18	6.07
liv)	50 × 50	1.9	2.80	3.56	13.6	1.95	5.42	6.37
lv)	60 × 60	1.2	2.19	2.79	15.9	2.39	5.31	6.11
lvi)	60 × 60	1.4	2.54	3.23	18.3	2.38	6.12	7.06
lvii)	60 × 60	1.6	2.88	3.67	20.7	2.37	6.89	7.99
lviii)	60 × 60	1.8	3.22	4.11	22.9	2.36	7.65	8.90
lix)	60 × 60	1.9	3.39	4.32	24.1	2.36	8.02	9.35
lx)	63.5 × 63.5	1.2	2.32	2.95	19.0	2.54	5.98	6.87
lxi)	63.5 × 63.5	1.4	2.69	3.43	21.9	2.53	6.89	7.94
lxii)	63.5 × 63.5	1.6	3.06	3.90	24.7	2.52	7.77	8.99
lxiii)	63.5 × 63.5	1.8	3.42	4.36	27.4	2.51	8.63	10.02
lxiv)	63.5 × 63.5	1.9	3.60	4.59	28.7	2.50	9.05	10.53
lxv)	63.5 × 63.5	2.4	4.49	5.72	35.1	2.48	11.05	12.98
lxvi)	70 × 70	1.2	2.56	3.27	25.6	2.80	7.32	8.39
lxvii)	70 × 70	1.4	2.98	3.79	29.5	2.79	8.44	9.71
lxviii)	70 × 70	1.6	3.38	4.31	33.4	2.78	9.53	11.00
lxix)	70 × 70	1.8	3.79	4.83	37.1	2.77	10.60	12.27
lxx)	70 × 70	1.9	3.99	5.08	38.9	2.77	11.12	12.90

Table 3 (Continued)

SI No.	Size (Depth × Width)	Thickness	Weight	Area of Section	Moment of Inertia	Radius of Gyration	Elastic Modulus	Plastic Modulus
	mm	mm	kg/m	cm <sup>2</sup>	cm <sup>4</sup>	cm	cm <sup>3</sup>	cm <sup>3</sup>
(1)	(2)	(3)	(4)	(5)	(6)	(7)	(8)	(9)
lxix)	70 × 70	2.4	4.98	6.34	47.7	2.74	13.63	15.94
lxx)	72 × 72	1.2	2.64	3.36	27.9	2.88	7.76	8.89
lxxi)	72 × 72	1.4	3.06	3.90	32.2	2.87	8.95	10.29
lxxii)	72 × 72	1.6	3.49	4.44	36.4	2.86	10.11	11.66
lxxiii)	72 × 72	1.8	3.90	4.97	40.5	2.85	11.24	13.01
lxxiv)	72 × 72	1.9	4.11	5.23	42.5	2.85	11.80	13.68
lxxv)	72 × 72	2.4	5.13	6.53	52.1	2.82	14.48	16.92
lxxvi)	75 × 75	1.2	2.75	3.51	31.65	3.00	8.44	9.67
lxxvii)	75 × 75	1.4	3.20	4.07	36.52	3.00	9.74	11.19
lxxviii)	75 × 75	1.6	3.64	4.63	41.29	2.99	11.01	12.69
lxxix)	75 × 75	1.8	4.07	5.19	45.94	2.98	12.25	14.16
lxxx)	75 × 75	1.9	4.29	5.46	48.23	2.97	12.86	14.89
lxxxii)	75 × 75	2.5	5.56	7.09	61.38	2.94	16.37	19.12
lxxxiii)	75 × 75	2.9	6.40	8.15	69.62	2.92	18.57	21.82
lxxxiv)	80 × 80	1.2	2.94	3.75	38.57	3.21	9.64	11.03
lxxxv)	80 × 80	1.4	3.42	4.35	44.54	3.20	11.13	12.77
lxxxvi)	80 × 80	1.6	3.89	4.95	50.38	3.19	12.60	14.49
lxxxvii)	80 × 80	1.8	4.35	5.55	56.10	3.18	14.03	16.18
lxxxviii)	80 × 80	1.9	4.59	5.84	58.91	3.18	14.73	17.02
lxxxix)	80 × 80	2.0	4.82	6.14	61.70	3.17	15.42	17.85
lxxxix)	80 × 80	2.5	5.96	7.59	75.1	3.15	18.79	21.89
xc)	80 × 80	2.9	6.85	8.73	85.4	3.13	21.34	25.01
xcii)	88.9 × 88.9	1.2	3.28	4.17	53.2	3.57	11.98	13.68
xciii)	88.9 × 88.9	1.4	3.81	4.85	61.6	3.56	13.85	15.86
xciv)	88.9 × 88.9	1.6	4.33	5.52	69.7	3.55	15.68	18.00
xcv)	88.9 × 88.9	1.8	4.86	6.19	77.7	3.54	17.48	20.12
xcvi)	88.9 × 88.9	1.9	5.12	6.52	81.6	3.54	18.37	21.16
xcvii)	88.9 × 88.9	2.0	5.38	6.85	85.5	3.53	19.24	22.20
xcviii)	88.9 × 88.9	2.5	6.66	8.48	104.5	3.51	23.50	27.29
xcviii)	88.9 × 88.9	2.9	7.66	9.76	118.9	3.49	26.76	31.23
xcix)	90 × 90	1.2	3.32	4.23	55.3	3.62	12.29	14.03
c)	90 × 90	1.4	3.86	4.91	63.9	3.61	14.20	16.26
ci)	90 × 90	1.6	4.39	5.59	72.4	3.60	16.09	18.46
cii)	90 × 90	1.8	4.92	6.27	80.7	3.59	17.93	20.63
ciii)	90 × 90	1.9	5.18	6.60	84.8	3.58	18.84	21.71

Table 3 (Continued)

SI No.	Size (Depth × Width)	Thickness	Weight	Area of Section	Moment of Inertia	Radius of Gyration	Elastic Modulus	Plastic Modulus
	mm	mm	kg/m	cm <sup>2</sup>	cm <sup>4</sup>	cm	cm <sup>3</sup>	cm <sup>3</sup>
(1)	(2)	(3)	(4)	(5)	(6)	(7)	(8)	(9)
civ)	90 × 90	2.0	5.45	6.94	88.9	3.58	19.75	22.78
cv)	90 × 90	2.5	6.74	8.59	108.5	3.56	24.12	28.00
cvi)	90 × 90	2.9	7.76	9.89	123.6	3.54	27.47	32.05
cvii)	91.5 × 91.5	1.2	3.37	4.30	58.1	3.68	12.71	14.51
cviii)	91.5 × 91.5	1.4	3.92	5.00	67.2	3.67	14.70	16.82
cix)	91.5 × 91.5	1.6	4.46	5.69	76.2	3.66	16.65	19.10
cx)	91.5 × 91.5	1.8	5.00	6.37	84.9	3.65	18.56	21.35
cxii)	91.5 × 91.5	1.9	5.27	6.72	89.2	3.65	19.51	22.46
cxiii)	91.5 × 91.5	2.0	5.54	7.06	93.5	3.64	20.44	23.57
cxiiii)	91.5 × 91.5	2.5	6.86	8.74	114.3	3.62	24.98	28.98
cxv)	91.5 × 91.5	2.9	7.90	10.06	130.2	3.60	28.45	33.18
cxvi)	100 × 100	1.2	3.69	4.71	76.2	4.03	15.25	17.39
cxvii)	100 × 100	1.4	4.29	5.47	88.2	4.02	17.65	20.17
cxviii)	100 × 100	1.6	4.89	6.23	100.0	4.01	20.00	22.91
cxix)	100 × 100	1.8	5.48	6.99	111.6	4.00	22.32	25.62
cxix)	100 × 100	1.9	5.78	7.36	117.3	3.99	23.47	26.97
cxx)	100 × 100	2.0	6.07	7.74	123.0	3.99	24.60	28.30
cxxi)	100 × 100	2.5	7.53	9.59	150.6	3.96	30.12	34.86
cxxii)	100 × 100	2.9	8.67	11.05	171.85	3.94	34.37	39.95
cxxiii)	113.5 × 113.5	1.6	5.57	7.10	147.38	4.56	25.97	29.68
cxxiv)	113.5 × 113.5	1.8	6.25	7.96	164.62	4.55	29.01	33.22
cxxv)	113.5 × 113.5	1.9	6.58	8.39	173.15	4.54	30.51	34.97
cxxvi)	113.5 × 113.5	2.0	6.92	8.82	181.61	4.54	32.00	36.72
cxxvii)	113.5 × 113.5	2.5	8.59	10.94	222.95	4.51	39.29	45.30
cxxviii)	113.5 × 113.5	2.9	9.90	12.61	254.89	4.50	44.91	52.00
cxxix)	120 × 120	1.8	6.62	8.43	195.24	4.81	32.54	37.23
cxxx)	120 × 120	1.9	6.97	8.88	205.39	4.81	34.23	39.20
cxxxi)	120 × 120	2.0	7.33	9.34	215.47	4.80	35.91	41.16
cxxxii)	120 × 120	2.5	9.10	11.59	264.78	4.78	44.13	50.82
cxxxiii)	120 × 120	2.9	10.49	13.37	302.96	4.76	50.49	58.37
cxxxiv)	125 × 125	2.0	7.64	9.74	244.20	5.01	39.07	44.75
cxxxv)	125 × 125	2.5	9.49	12.09	300.30	4.98	48.05	55.28
cxxxvi)	125 × 125	2.9	10.95	13.95	343.80	4.97	55.01	63.52
cxxxvii)	132 × 132	3.2	12.73	16.22	444.82	5.24	67.40	77.92
cxxxviii)	132 × 132	3.6	14.25	18.16	494.19	5.22	74.88	86.87

Table 3 (Concluded)

SI No.	Size (Depth × Width)	Thickness	Weight	Area of Section	Moment of Inertia	Radius of Gyration	Elastic Modulus	Plastic Modulus
	mm	mm	kg/m	cm <sup>2</sup>	cm <sup>4</sup>	cm	cm <sup>3</sup>	cm <sup>3</sup>
(1)	(2)	(3)	(4)	(5)	(6)	(7)	(8)	(9)
cxxxix)	132 × 132	3.9	15.38	19.59	530.34	5.20	80.35	93.47
cxl)	140 × 140	3.2	13.54	17.25	533.7	5.56	76.25	88.01
cxli)	140 × 140	3.6	15.16	19.31	593.4	5.54	84.77	98.17
cxlii)	140 × 140	3.9	16.36	20.84	637.2	5.53	91.03	105.67
cxliii)	150 × 150	3.2	14.54	18.53	660.6	5.97	88.08	101.49
cxliv)	150 × 150	3.6	16.29	20.75	735.1	5.95	98.01	113.28
cxlv)	150 × 150	3.9	17.58	22.40	789.8	5.94	105.30	121.99
cxlvi)	160 × 160	3.2	15.55	19.81	806.1	6.38	100.77	115.93
cxlvii)	160 × 160	3.6	17.42	22.19	897.6	6.36	112.20	129.46
cxlviii)	160 × 160	3.9	18.81	23.96	964.9	6.35	120.62	139.47
cxlix)	180 × 180	3.6	19.68	25.07	1 291.2	7.18	143.47	165.07
cl)	180 × 180	3.9	21.26	27.08	1 389.3	7.16	154.37	177.94

Table 4 Dimension and Properties of Rectangular Welded Carbon Steel Section

(Clause 10)

SI No.	Size (Depth × Width)	Thickness	Mass per Unit Length	Area of Section	Moment of Inertia about		Radius of Gyration about		Elastic Modulus about		Plastic Modulus about	
					X-X	Y-Y	X-X	Y-Y	X-X	Y-Y	X-X	Y-Y
	mm	mm	kg/m	cm <sup>2</sup>	cm <sup>4</sup>	cm <sup>4</sup>	cm	cm	cm <sup>3</sup>	cm <sup>3</sup>	cm <sup>3</sup>	cm <sup>3</sup>
(1)	(2)	(3)	(4)	(5)	(6)	(7)	(8)	(9)	(10)	(11)	(12)	(13)
i)	40 × 20	1.2	1.06	1.35	2.7	0.92	1.42	0.83	1.36	0.92	1.71	1.05
ii)	40 × 20	1.4	1.22	1.55	3.1	1.04	1.41	0.82	1.55	1.04	1.95	1.20
iii)	40 × 20	1.6	1.37	1.75	3.4	1.15	1.40	0.81	1.72	1.15	2.18	1.34
iv)	40 × 20	1.8	1.53	1.95	3.8	1.25	1.39	0.80	1.88	1.25	2.40	1.47
v)	40 × 20	1.9	1.60	2.04	3.9	1.30	1.38	0.80	1.95	1.30	2.51	1.54
vi)	50 × 25	1.2	1.34	1.71	5.5	1.88	1.80	1.05	2.20	1.50	2.73	1.69
vii)	50 × 25	1.4	1.55	1.97	6.3	2.13	1.78	1.04	2.51	1.71	3.14	1.94
viii)	50 × 25	1.6	1.75	2.23	7.02	2.37	1.77	1.03	2.81	1.90	3.53	2.17
ix)	50 × 25	1.8	1.95	2.49	7.72	2.60	1.76	1.02	3.09	2.08	3.90	2.40
x)	50 × 25	1.9	2.05	2.61	8.06	2.71	1.76	1.02	3.22	2.16	4.08	2.51
xi)	50 × 30	1.2	1.43	1.83	6.2	2.83	1.85	1.25	2.49	1.89	3.02	2.13
xii)	50 × 30	1.4	1.66	2.11	7.1	3.23	1.83	1.24	2.84	2.15	3.48	2.45
xiii)	50 × 30	1.6	1.88	2.39	8.0	3.60	1.82	1.23	3.18	2.40	3.91	2.75
xiv)	50 × 30	1.8	2.09	2.67	8.8	3.96	1.81	1.22	3.51	2.64	4.33	3.04
xv)	50 × 30	1.9	2.20	2.80	9.2	4.13	1.81	1.21	3.66	2.75	4.54	3.19

Table 4 (Continued)

SI No.	Size (Depth × Width)	Thickness	Mass per Unit Length	Area of Section	Moment of Inertia about		Radius of Gyration about		Elastic Modulus about		Plastic Modulus about	
					X-X	Y-Y	X-X	Y-Y	X-X	Y-Y	X-X	Y-Y
	mm	mm	kg/m	cm <sup>2</sup>	cm <sup>4</sup>	cm <sup>4</sup>	cm	cm	cm <sup>3</sup>	cm <sup>3</sup>	cm <sup>3</sup>	cm <sup>3</sup>
(1)	(2)	(3)	(4)	(5)	(6)	(7)	(8)	(9)	(10)	(11)	(12)	(13)
xvi)	60 × 40	1.2	1.81	2.31	11.8	6.34	2.26	1.66	3.93	3.17	4.70	3.57
xvii)	60 × 40	1.4	2.10	2.67	13.5	7.26	2.25	1.65	4.51	3.63	5.42	4.11
xviii)	60 × 40	1.6	2.38	3.03	15.2	8.15	2.24	1.64	5.07	4.08	6.12	4.64
xix)	60 × 40	1.8	2.66	3.39	16.85	9.01	2.23	1.63	5.62	4.50	6.81	5.15
xx)	60 × 40	1.9	2.80	3.56	17.64	9.42	2.22	1.63	5.88	4.71	7.14	5.41
xxi)	66 × 33	1.2	1.79	2.28	13.06	4.48	2.39	1.40	3.96	2.72	4.87	3.02
xxii)	66 × 33	1.4	2.07	2.64	14.99	5.13	2.38	1.39	4.54	3.11	5.61	3.48
xxiii)	66 × 33	1.6	2.35	3.00	16.85	5.74	2.37	1.38	5.11	3.48	6.34	3.92
xxiv)	66 × 33	1.8	2.63	3.35	18.64	6.33	2.36	1.37	5.65	3.84	7.04	4.35
xxv)	66 × 33	1.9	2.77	3.52	19.51	6.62	2.35	1.37	5.91	4.01	7.39	4.56
xxvi)	70 × 30	1.2	1.81	2.31	14.25	3.83	2.49	1.29	4.07	2.55	5.09	2.82
xxvii)	70 × 30	1.4	1.66	2.11	7.11	3.23	1.83	1.24	2.84	2.15	3.48	2.45
xxviii)	70 × 30	1.6	1.88	2.39	7.95	3.60	1.82	1.23	3.18	2.40	3.91	2.75
xxix)	70 × 30	1.8	2.09	2.67	8.76	3.96	1.81	1.22	3.51	2.64	4.33	3.04
xxx)	70 × 30	1.9	2.20	2.80	9.15	4.13	1.81	1.21	3.66	2.75	4.54	3.19
xxxii)	70 × 50	1.2	2.19	2.79	19.9	11.93	2.68	2.07	5.69	4.77	6.74	5.37
xxxiii)	70 × 50	1.4	2.54	3.23	22.9	13.72	2.66	2.06	6.56	5.49	7.79	6.20
xxxiiii)	70 × 50	1.6	2.88	3.67	25.9	15.45	2.65	2.05	7.39	6.18	8.81	7.01
xxxv)	70 × 50	1.8	3.22	4.11	28.7	17.13	2.64	2.04	8.20	6.85	9.82	7.80
xxxvi)	70 × 50	1.9	3.39	4.32	30.1	17.95	2.64	2.04	8.60	7.18	10.31	8.20
xxxvii)	80 × 40	1.2	2.19	2.79	23.7	8.15	2.91	1.71	5.92	4.07	7.25	4.50
xxxviii)	80 × 40	1.4	2.54	3.23	27.2	9.35	2.90	1.70	6.81	4.68	8.37	5.19
xxxix)	80 × 40	1.6	2.88	3.67	30.71	10.52	2.89	1.69	7.68	5.26	9.47	5.87
xl)	80 × 40	1.8	3.22	4.11	34.08	11.64	2.88	1.68	8.52	5.82	10.55	6.53
xli)	80 × 40	1.9	3.39	4.32	35.73	12.18	2.88	1.68	8.93	6.09	11.08	6.85
xlii)	80 × 50	1.2	2.37	3.03	27.39	13.36	3.01	2.10	6.85	5.34	8.19	5.95
xliii)	80 × 50	1.4	2.76	3.51	31.56	15.37	3.00	2.09	7.89	6.15	9.47	6.88
xliv)	80 × 50	1.6	3.13	3.99	35.63	17.33	2.99	2.08	8.91	6.93	10.73	7.78
xlv)	80 × 50	1.8	3.51	4.47	39.59	19.22	2.98	2.07	9.90	7.69	11.96	8.67
xlvi)	80 × 50	1.9	3.69	4.70	41.53	20.15	2.97	2.07	10.38	8.06	12.57	9.11
xlvii)	80 × 60	1.2	2.56	3.27	31.1	20.09	3.09	2.48	7.78	6.70	9.14	7.52
xlviii)	80 × 60	1.4	2.98	3.79	35.9	23.15	3.08	2.47	8.97	7.72	10.57	8.70
xlviii)	80 × 60	1.6	3.38	4.31	40.5	26.14	3.07	2.46	10.14	8.71	11.98	9.86

Table 4 (Continued)

Sl No.	Size (Depth × Width)	Thickness	Mass per Unit Length	Area of Section	Moment of Inertia about		Radius of Gyration about		Elastic Modulus about		Plastic Modulus about	
					X-X	Y-Y	X-X	Y-Y	X-X	Y-Y	X-X	Y-Y
	mm	mm	kg/m	cm <sup>2</sup>	cm <sup>4</sup>	cm <sup>4</sup>	cm	cm	cm <sup>3</sup>	cm <sup>3</sup>	cm <sup>3</sup>	cm <sup>3</sup>
(1)	(2)	(3)	(4)	(5)	(6)	(7)	(8)	(9)	(10)	(11)	(12)	(13)
xlix)	80 × 60	1.8	3.79	4.83	45.1	29.04	3.06	2.45	11.27	9.68	13.37	11.00
l)	80 × 60	1.9	3.99	5.08	47.3	30.47	3.05	2.45	11.83	10.16	14.05	11.56
li)	90 × 50	1.2	2.56	3.27	36.4	14.79	3.34	2.13	8.08	5.92	9.77	6.54
lii)	90 × 50	1.4	2.98	3.79	41.9	17.03	3.33	2.12	9.32	6.81	11.30	7.56
liii)	90 × 50	1.6	3.38	4.31	47.38	19.20	3.32	2.11	10.53	7.68	12.80	8.56
liv)	90 × 50	1.8	3.79	4.83	52.69	21.32	3.30	2.10	11.71	8.53	14.28	9.54
lv)	90 × 50	1.9	3.99	5.08	55.30	22.35	3.30	2.10	12.29	8.94	15.01	10.02
lvi)	96 × 48	1.2	2.64	3.36	41.4	14.31	3.51	2.06	8.63	5.96	10.54	6.55
lvii)	96 × 48	1.4	3.06	3.90	47.8	16.47	3.50	2.05	9.96	6.86	12.20	7.57
lviii)	96 × 48	1.6	3.49	4.44	54.03	18.57	3.49	2.05	11.26	7.74	13.82	8.58
lix)	96 × 48	1.8	3.90	4.97	60.11	20.61	3.48	2.04	12.52	8.59	15.42	9.56
lx)	96 × 48	1.9	4.11	5.23	63.09	21.61	3.47	2.03	13.14	9.00	16.21	10.04
lxi)	100 × 40	1.2	2.56	3.27	41.10	9.95	3.55	1.75	8.22	4.98	10.27	5.43
lxii)	100 × 40	1.4	2.98	3.79	47.40	11.44	3.54	1.74	9.48	5.72	11.88	6.27
lxiii)	100 × 40	1.6	3.38	4.31	53.5	12.88	3.52	1.73	10.71	6.44	13.47	7.10
lxiv)	100 × 40	1.8	3.79	4.83	59.5	14.27	3.51	1.72	11.91	7.13	15.02	7.90
lxv)	100 × 40	1.9	3.99	5.08	62.5	14.95	3.51	1.71	12.49	7.47	15.79	8.30
lxvi)	100 × 40	2.0	4.19	5.34	65.4	15.61	3.50	1.71	13.07	7.81	16.54	8.69
lxvii)	100 × 40	2.4	4.98	6.34	76.6	18.17	3.48	1.69	15.32	9.08	19.51	10.22
lxviii)	100 × 50	1.2	2.75	3.51	46.96	16.22	3.66	2.15	9.39	6.49	11.46	7.12
lxix)	100 × 50	1.4	3.20	4.07	54.21	18.68	3.65	2.14	10.84	7.47	13.26	8.24
lxx)	100 × 50	1.6	3.64	4.63	61.3	21.08	3.64	2.13	12.26	8.43	15.04	9.33
lxxi)	100 × 50	1.8	4.07	5.19	68.2	23.41	3.63	2.12	13.64	9.36	16.79	10.41
lxxii)	100 × 50	1.9	4.29	5.46	71.6	24.55	3.62	2.12	14.32	9.82	17.65	10.94
lxxiii)	100 × 50	2.0	4.50	5.74	75.0	25.67	3.62	2.12	15.00	10.27	18.50	11.46
lxxiv)	100 × 50	2.4	5.35	6.82	88.0	30.01	3.59	2.10	17.61	12.00	21.85	13.51
lxxv)	100 × 60	1.2	2.94	3.75	52.82	24.24	3.76	2.54	10.56	8.08	12.64	8.94
lxxvi)	100 × 60	1.4	3.42	4.35	61.01	27.96	3.74	2.54	12.20	9.32	14.64	10.34
lxxvii)	100 × 60	1.6	3.89	4.95	69.04	31.60	3.73	2.53	13.81	10.53	16.61	11.73
lxxviii)	100 × 60	1.8	4.35	5.55	76.89	35.14	3.72	2.52	15.38	11.71	18.55	13.09
lxxix)	100 × 60	1.9	4.59	5.84	80.76	36.88	3.72	2.51	16.15	12.29	19.51	13.76
lxxx)	100 × 60	2.0	4.82	6.14	84.58	38.60	3.71	2.51	16.92	12.87	20.46	14.43
lxxxii)	100 × 60	2.4	5.73	7.30	99.46	45.27	3.69	2.49	19.89	15.09	24.19	17.04

Table 4 (Continued)

SI No.	Size (Depth × Width)	Thickness	Mass per Unit Length	Area of Section	Moment of Inertia about		Radius of Gyration about		Elastic Modulus about		Plastic Modulus about	
					X-X	Y-Y	X-X	Y-Y	X-X	Y-Y	X-X	Y-Y
	mm	mm	kg/m	cm <sup>2</sup>	cm <sup>4</sup>	cm <sup>4</sup>	cm	cm	cm <sup>3</sup>	cm <sup>3</sup>	cm <sup>3</sup>	cm <sup>3</sup>
(1)	(2)	(3)	(4)	(5)	(6)	(7)	(8)	(9)	(10)	(11)	(12)	(13)
lxxxii)	100 × 80	1.2	3.32	4.23	64.5	46.02	3.91	3.30	12.91	11.50	15.02	12.92
lxxxiii)	100 × 80	1.4	3.86	4.91	74.6	53.19	3.90	3.29	14.92	13.30	17.41	14.97
lxxxiv)	100 × 80	1.6	4.39	5.59	84.5	60.22	3.89	3.28	16.91	15.05	19.76	17.00
lxxxv)	100 × 80	1.8	4.92	6.27	94.3	67.11	3.88	3.27	18.85	16.78	22.09	19.00
lxxxvi)	100 × 80	1.9	5.18	6.60	99.0	70.51	3.87	3.27	19.81	17.63	23.24	19.99
lxxxvii)	100 × 80	2.0	5.45	6.94	103.8	73.87	3.87	3.26	20.76	18.47	24.38	20.97
lxxxviii)	100 × 80	2.4	6.48	8.26	122.3	86.97	3.85	3.24	24.47	21.74	28.88	24.82
lxxxix)	120 × 60	1.2	3.32	4.23	82.0	28.39	4.41	2.59	13.67	9.46	16.63	10.35
xc)	120 × 60	1.4	3.86	4.91	94.8	32.77	4.39	2.58	15.81	10.92	19.28	11.98
xc i)	120 × 60	1.6	4.39	5.59	107.4	37.05	4.38	2.57	17.91	12.35	21.89	13.60
xc ii)	120 × 60	1.8	4.92	6.27	119.8	41.24	4.37	2.57	19.96	13.75	24.46	15.19
xc iii)	120 × 60	1.9	5.18	6.60	125.9	43.30	4.37	2.56	20.98	14.43	25.74	15.97
xc iv)	120 × 60	2.0	5.45	6.94	131.9	45.33	4.36	2.56	21.99	15.11	27.00	16.75
xc v)	120 × 60	2.4	6.48	8.26	155.5	53.24	4.34	2.54	25.91	17.75	31.97	19.81
xc vi)	120 × 80	1.2	3.69	4.71	98.9	53.47	4.59	3.37	16.49	13.37	19.48	14.81
xc vii)	120 × 80	1.4	4.29	5.47	114.5	61.84	4.58	3.36	19.09	15.46	22.60	17.18
xc viii)	120 × 80	1.6	4.89	6.23	129.9	70.05	4.57	3.35	21.64	17.51	25.67	19.51
xc ix)	120 × 80	1.8	5.48	6.99	144.9	78.12	4.55	3.34	24.16	19.53	28.72	21.81
c)	120 × 80	1.9	5.78	7.36	152.4	82.10	4.55	3.34	25.40	20.52	30.22	22.95
ci)	120 × 80	2.0	6.07	7.74	159.8	86.04	4.54	3.33	26.63	21.51	31.72	24.09
c ii)	120 × 80	2.4	7.24	9.22	188.7	101.43	4.52	3.32	31.44	25.36	37.62	28.55
c iii)	120 × 80	2.9	8.67	11.05	223.4	119.85	4.50	3.29	37.24	29.96	44.79	33.96
c iv)	122 × 61	1.2	3.37	4.30	86.3	29.86	4.48	2.64	14.14	9.79	17.20	10.70
cv)	122 × 61	1.4	3.92	5.00	99.8	34.48	4.47	2.63	16.35	11.30	19.94	12.40
cv i)	122 × 61	1.6	4.46	5.69	113.0	38.99	4.46	2.62	18.53	12.78	22.64	14.07
cv ii)	122 × 61	1.8	5.00	6.37	126.0	43.41	4.45	2.61	20.66	14.23	25.31	15.71
cv iii)	122 × 61	1.9	5.27	6.72	132.5	45.58	4.44	2.60	21.72	14.94	26.63	16.53
cv ix)	122 × 61	2.0	5.54	7.06	138.8	47.72	4.44	2.60	22.76	15.65	27.94	17.33
cx)	122 × 61	2.4	6.60	8.40	163.7	56.06	4.41	2.58	26.83	18.38	33.09	20.50
cx i)	127 × 50	1.2	3.26	4.15	84.7	20.08	4.52	2.20	13.34	8.03	16.63	8.70
cx ii)	127 × 50	1.4	3.79	4.83	97.9	23.15	4.50	2.19	15.42	9.26	19.27	10.08
cx iii)	127 × 50	1.6	4.31	5.50	110.9	26.14	4.49	2.18	17.46	10.46	21.88	11.42
cx iv)	127 × 50	1.8	4.83	6.16	123.6	29.06	4.48	2.17	19.46	11.62	24.44	12.75



Table 4 (Concluded)

SI No.	Size (Depth × Width)	Thickness	Mass per Unit Length	Area of Section	Moment of Inertia about		Radius of Gyration about		Elastic Modulus about		Plastic Modulus about	
					X-X	Y-Y	X-X	Y-Y	X-X	Y-Y	X-X	Y-Y
	mm	mm	kg/m	cm <sup>2</sup>	cm <sup>4</sup>	cm <sup>4</sup>	cm	cm	cm <sup>3</sup>	cm <sup>3</sup>	cm <sup>3</sup>	cm <sup>3</sup>
(1)	(2)	(3)	(4)	(5)	(6)	(7)	(8)	(9)	(10)	(11)	(12)	(13)
cxv)	127 × 50	1.9	5.09	6.49	129.8	30.49	4.47	2.17	20.45	12.19	25.72	13.40
cxvi)	127 × 50	2.0	5.35	6.82	136.0	31.90	4.47	2.16	21.43	12.76	26.98	14.05
cxvii)	127 × 50	2.4	6.37	8.12	160.2	37.36	4.44	2.15	25.24	14.94	31.93	16.60
cxviii)	127 × 50	2.9	7.62	9.71	189.1	43.78	4.41	2.12	29.78	17.51	37.93	19.65
cxix)	140 × 80	1.6	5.39	6.87	187.66	79.89	5.23	3.41	26.81	19.97	32.23	22.02
cxx)	140 × 80	2.0	6.70	8.54	231.21	98.21	5.20	3.39	33.03	24.55	39.86	27.21
cxxi)	140 × 80	2.9	9.58	12.21	324.42	137.10	5.16	3.35	46.35	34.27	56.41	38.43
cxxii)	140 × 80	3.2	10.52	13.41	354.0	149.36	5.14	3.34	50.58	37.34	61.75	42.03
cxxiii)	140 × 80	3.6	11.76	14.99	392.4	165.19	5.12	3.32	56.06	41.30	68.71	46.73
cxxiv)	140 × 80	3.9	12.68	16.16	420.4	176.66	5.10	3.31	60.06	44.17	73.83	50.18
cxxv)	145 × 82	1.6	5.57	7.10	207.5	86.95	5.41	3.50	28.62	21.21	34.42	23.35
cxxvi)	145 × 82	2.0	6.92	8.82	255.8	106.94	5.39	3.48	35.28	26.08	42.59	28.86
cxxvii)	145 × 82	2.9	9.90	12.61	359.3	149.45	5.34	3.44	49.55	36.45	60.33	40.80
cxxviii)	145 × 82	3.2	10.88	13.85	392.20	162.88	5.32	3.43	54.10	39.73	66.05	44.64
cxxix)	145 × 82	3.6	12.16	15.49	434.93	180.22	5.30	3.41	59.99	43.96	73.52	49.65
cxxx)	145 × 82	3.9	13.11	16.71	466.10	192.81	5.28	3.40	64.29	47.03	79.01	53.32
cxxxii)	150 × 100	1.6	6.15	7.83	256.9	138.76	5.73	4.21	34.25	27.75	40.49	30.78
cxxxiii)	150 × 100	2.0	7.64	9.74	317.0	171.03	5.71	4.19	42.27	34.21	50.15	38.10
cxxxiv)	150 × 100	2.9	10.95	13.95	446.7	240.23	5.66	4.15	59.56	48.05	71.19	54.03
cxxxv)	150 × 100	3.2	12.03	15.33	488.2	262.26	5.64	4.14	65.09	52.45	78.00	59.18
cxxxvi)	150 × 100	3.6	13.46	17.15	542.1	290.85	5.62	4.12	72.28	58.17	86.92	65.91
cxxxvii)	150 × 100	3.9	14.52	18.50	581.6	311.71	5.61	4.10	77.55	62.34	93.50	70.86
cxxxviii)	160 × 80	1.6	5.90	7.51	259.2	89.73	5.87	3.46	32.40	22.43	39.42	24.53
cxxxix)	160 × 80	2.0	7.33	9.34	319.7	110.38	5.85	3.44	39.97	27.59	48.79	30.33
cxli)	160 × 80	2.9	10.49	13.37	449.8	154.35	5.80	3.40	56.23	38.59	69.20	42.90
cxlii)	160 × 80	3.2	11.53	14.69	491.4	168.25	5.78	3.38	61.42	42.06	75.79	46.95
cxliii)	160 × 80	3.6	12.90	16.43	545.3	186.21	5.76	3.37	68.17	46.55	84.42	52.23
cxliiii)	160 × 80	3.9	13.91	17.72	584.7	199.27	5.74	3.35	73.09	49.82	90.76	56.11
cxlv)	172 × 92	3.2	12.73	16.22	642.42	245.11	6.29	3.89	74.70	53.29	91.32	59.40
cxlvi)	172 × 92	3.6	14.25	18.16	713.91	271.80	6.27	3.87	83.01	59.09	101.81	66.17
cxlvii)	172 × 92	3.9	15.38	19.59	766.28	291.26	6.25	3.86	89.10	63.32	109.54	71.15
cxlviii)	180 × 100	3.2	13.54	17.25	758.1	307.25	6.63	4.22	84.23	61.45	102.43	68.47
cxlix)	180 × 100	3.6	15.16	19.31	843.1	341.06	6.61	4.20	93.68	68.21	114.27	76.32
cl)	180 × 100	3.9	16.36	20.84	905.5	365.76	6.59	4.19	100.61	73.15	123.00	82.11
cl)	200 × 100	3.6	16.29	20.75	1 091.42	374.53	7.25	4.25	109.14	74.91	134.29	83.26
cl)	200 × 100	3.9	17.58	22.40	1 172.82	401.80	7.24	4.24	117.28	80.36	144.62	89.60

## ANNEX A

*(Clause 2)*

## LIST OF REFERRED STANDARDS

<i>IS No.</i>	<i>Title</i>	<i>IS No.</i>	<i>Title</i>
IS 209 : 1992	Zinc ingot — Specification ( <i>fourth revision</i> )	IS 1387 : 1993	General requirements for the supply of metallurgical materials ( <i>second revision</i> )
IS 228 (all parts)	Methods of chemical analysis of steels	IS 1608 (Part 1) : 2022/ISO 6892-1 : 2019	Metallic materials — Tensile testing: Part 1 Method of test at room temperature ( <i>fifth revision</i> )
IS 277 : 2018	Galvanized steel strips and sheets (plain and corrugated) — Specification ( <i>seventh revision</i> )	IS 2633 : 1986	Methods of testing uniformity of coating on zinc coated articles ( <i>second revision</i> )
IS 513	Cold reduced carbon steel sheet and strip:	IS 10748 : 2004	Hot-rolled steel strip for welded tubes and pipes — Specification ( <i>second revision</i> )
(Part 1) : 2016	Cold forming and drawing purpose ( <i>sixth revision</i> )	IS 13229 : 1991	Zinc for galvanizing — Specification
(Part 2) : 2016	High tensile and multi-phase steel ( <i>sixth revision</i> )		

access Indian Standards, click on the link below:

[https://www.services.bis.gov.in/php/BIS\\_2.0/bisconnect/knownyourstandards/Indian\\_standards/isdetails/](https://www.services.bis.gov.in/php/BIS_2.0/bisconnect/knownyourstandards/Indian_standards/isdetails/)

## ANNEX B

(Clause 8)

## GEOMETRICAL DATA OF HOLLOW SECTION

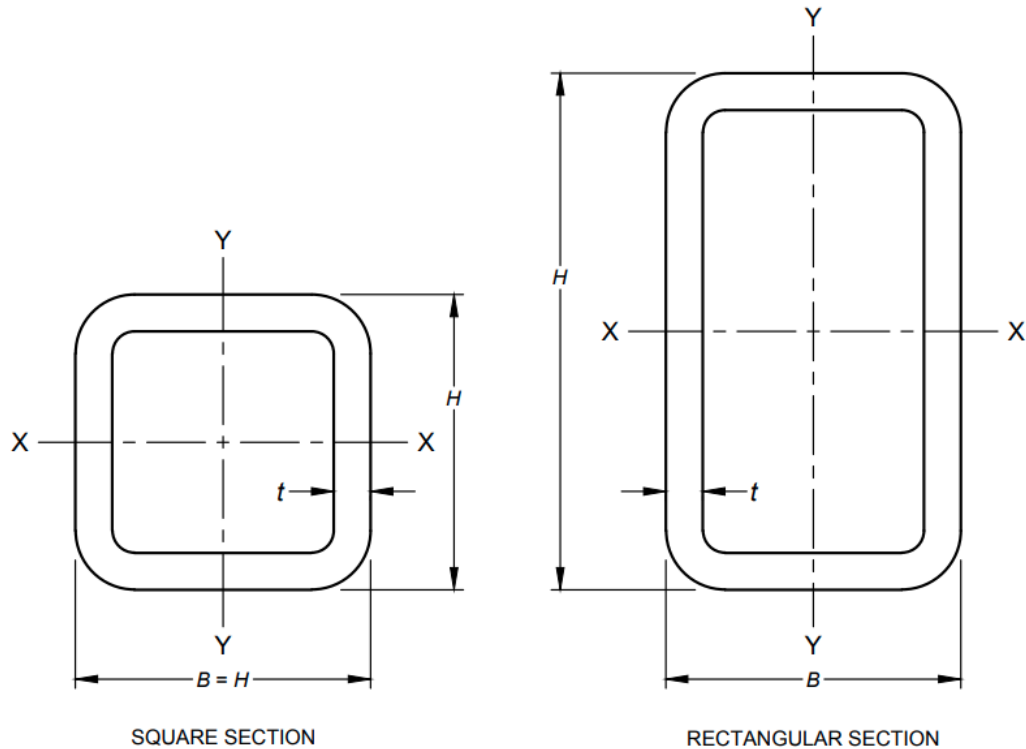

Area of cross-section =  $A = 2 t [(B - 4 t) + (H - 4 t) + \frac{3}{2} \pi t]$  in  $\text{cm}^2$

Weight (kg/m) =  $W = 0.785 A$

For X-X axis:

$$\text{Moment of inertia} = I_x = t \frac{(H - 4 t)^3}{\sigma} + \frac{1}{2} \left[ \frac{(B - 4 t) t^3}{3} + (B - 4 t) (H - t)^2 t \right] + \frac{\pi t^4}{108} \left[ 405 - \frac{3 \cdot 136}{\pi^2} \right] + 3 \pi t^2 \left[ \frac{9\pi (H - 4 t) + 56 t}{18\pi} \right]^2 \text{ in } \text{cm}^4$$

$$\text{Elastic modulus} = Z_x = \frac{2I_x}{D} \text{ in } \text{cm}^3$$

$$\text{Plastic modulus} = S_x = t/2 (H - 4 t)^2 + t(B - 4 t) (H - t) + \frac{t^2}{\sigma} [9\pi (H - 4 t) + 56 t] \text{ in } \text{cm}^3$$

$$\text{Radius of gyration} = R_x = \sqrt{\frac{I_x}{A}} \text{ in } \text{cm}$$

For Y-Y axis:

$$\text{Moment of inertia} = I_y = \frac{t(B - 4 t)^3}{\sigma} + \frac{1}{2} \left[ \frac{(H - 4 t) t^3}{3} + (H - 4 t) (B - t)^2 t \right] + \frac{\pi t^4}{108} \left[ 405 - \frac{3 \cdot 136}{\pi^2} \right] + 3 \pi t^2 \left[ \frac{9\pi (B - 4 t) + 56 t}{18\pi} \right]^2 \text{ in } \text{cm}^4$$

$$\text{Elastic modulus} = Z_y = \frac{2I_y}{B} \text{ in } \text{cm}^3$$

$$\text{Plastic modulus} = S_y = t/2 (B - 4 t)^2 + t(H - 4 t) (B - t) + \frac{t^2}{\sigma} [9\pi (B - 4 t) + 56 t] \text{ in } \text{cm}^3$$

$$\text{Radius of gyration} = R_y = \sqrt{\frac{I_y}{A}} \text{ in } \text{cm}$$

NOTE — Letter symbols denoting various dimensions are the same as those used in [Table 1](#) and [Table 2](#).

## ANNEX C

*(Foreword)*

## COMMITTEE COMPOSITION

Steel Tubes, Pipes and Fittings Sectional Committee, MTD 19

<i>Organization</i>	<i>Representative(s)</i>
Steel Authority of India Limited, New Delhi	SHRI ARUNAVA DASGUPTA ( <i>Chairperson</i> )
Bharat Heavy Electrical Limited, New Delhi	SHRI K. ATHIMOOLAM SHRI M. KANNAN ( <i>Alternate</i> )
Chhattisgarh Mini Steel plant Association, Raipur	SHRI VIKAS AGARWAL SHRI MANISH DHUPPAD ( <i>Alternate</i> )
Delhi Jal Board, New Delhi	SHRI PRAVEEN BHARGAVA
Directorate General of Quality Assurance, New Delhi	SHRI BIKAS MANDAL SHRI K. YADAV ( <i>Alternate</i> )
Engineers India Limited, New Delhi	SHRI RAMESHWAR PRASAD SHRI SANJEEV GUPTA ( <i>Alternate</i> )
Federation of Industries of India, Thane	SHRI H. L. BHARDWAJ
GAIL (India) Limited, New Delhi	SHRI J. P. SAH
Goodluck Steel Tubes Limited, New Delhi	SHRI M. C. GARG SHRI U. D. SHARMA ( <i>Alternate</i> )
Gujarat Gas Company Limited, Ahmedabad	SHRI DHARMESH SAILOR SHRI PRAMATH SHAILESH ( <i>Alternate</i> )
Gujarat State Petronet Limited, Gandhinagar	SHRI N. BOSE BABU SHRI NILESH TANNA ( <i>Alternate</i> )
Howrah Pipe Fittings Manufacturers Welfare Association, Kolkata	SHRI MAHANANDA DHARA SHRI P. GHOSH ( <i>Alternate</i> )
Indian Oil Corporation Limited - Refineries and Pipelines Division, New Delhi	SHRI PARICHAY DAS
Indian Pipe Manufacturing Association, New Delhi	SHRI MAYANK SHARMA SHRI ANAND AYYA ( <i>Alternate</i> )
Indian Stainless Steel Development Association, Gurugram	SHRI ROHIT KUMAR SHRI NAGENDRA VIJAYVARGIA ( <i>Alternate</i> )
Indus Tubes Limited, Pitampura, New Delhi	SHRI I. P. JAIN SHRI C. K. KAUSHIK ( <i>Alternate</i> )
Jindal Pipes Limited, Hapur	SHRI MANOJ KUMAR GUPTA SHRI SANJAY KUMAR ( <i>Alternate</i> )
Lalita Infraprojects Private Limited, Kolkata	DR BUDDHADEB DUARI SHRI SUBHOJIT BHATTACHARYA ( <i>Alternate</i> )
Mazagon Dock Limited, Mumbai	SHRI VINOD KUMAR PARKEWAR SHRI HARSHIN DAVE ( <i>Alternate</i> )

<i>Organization</i>	<i>Representative(s)</i>
Ministry of Commerce and Industry, Department for Promotion of Industry and Internal Trade, New Delhi	SHRI T. S. G. NARAYANNEN SHRI S. K. JAIN ( <i>Alternate</i> )
RITES Limited, Gurugram	SHRI RAMENDRA KUMAR SHRI AJAY SHARMA ( <i>Alternate</i> )
Shri Bajrang Power and Ispat Limited, Raipur	SHRI BANWARI LAL CHOPRA SHRI PRAVEEN KUMAR ( <i>Alternate</i> )
Society of Indian Automobile Manufacturers, Delhi	SHRI P. K. BANERJEE SHRI AMIT KUMAR ( <i>Alternate</i> )
Surya Roshni Limited, Delhi	SHRI N. K. SINGLA SHRI NITIN JAIN ( <i>Alternate</i> )
Tata Steel Limited, Khopoli	SHRI UDYAN TYAGI
Tata Steel Limited, Kolkata	SHRI BRAJ B. PRASAD
Welspun India Limited, Mumbai	SHRI JIGNESH MAHENDRA CHOKSI SHRI PRAKASHMAL TATIA ( <i>Alternate</i> )
BIS Directorate General	SHRI SANJIV MAINI, SCIENTIST 'F'/SENIOR DIRECTOR AND HEAD (METALLURGICAL ENGINEERING) [REPRESENTING DIRECTOR GENERAL ( <i>Ex-officio</i> )]

*Member Secretary*  
SHRI SACHIN CHOUDHARY  
SCIENTIST 'C'/DEPUTY DIRECTOR  
(METALLURGICAL ENGINEERING), BIS





## Bureau of Indian Standards

BIS is a statutory institution established under the *Bureau of Indian Standards Act, 2016* to promote harmonious development of the activities of standardization, marking and quality certification of goods and attending to connected matters in the country.

### Copyright

BIS has the copyright of all its publications. No part of these publications may be reproduced in any form without the prior permission in writing of BIS. This does not preclude the free use, in the course of implementing the standard, of necessary details, such as symbols and sizes, type or grade designations. Enquiries relating to copyright be addressed to the Head (Publication & Sales), BIS.

### Review of Indian Standards

Amendments are issued to standards as the need arises on the basis of comments. Standards are also reviewed periodically; a standard along with amendments is reaffirmed when such review indicates that no changes are needed; if the review indicates that changes are needed, it is taken up for revision. Users of Indian Standards should ascertain that they are in possession of the latest amendments or edition by referring to the website-[www.bis.gov.in](http://www.bis.gov.in) or [www.standardsbis.in](http://www.standardsbis.in).

This Indian Standard has been developed from Doc No.: MTD 19 (11427).

### Amendments Issued Since Publication

Amend No.	Date of Issue	Text Affected

## BUREAU OF INDIAN STANDARDS

### Headquarters:

Manak Bhavan, 9 Bahadur Shah Zafar Marg, New Delhi 110002

Telephones: 2323 0131, 2323 3375, 2323 9402

Website: [www.bis.gov.in](http://www.bis.gov.in)

### Regional Offices:

	Telephones
Central : 601/A, Konnectus Tower -1, 6 <sup>th</sup> Floor, DMRC Building, Bhavbhuti Marg, New Delhi 110002	{ 2323 7617
Eastern : 8 <sup>th</sup> Floor, Plot No 7/7 & 7/8, CP Block, Sector V, Salt Lake, Kolkata, West Bengal 700091	{ 2367 0012 2320 9474
Northern : Plot No. 4-A, Sector 27-B, Madhya Marg, Chandigarh 160019	{ 265 9930
Southern : C.I.T. Campus, IV Cross Road, Taramani, Chennai 600113	{ 2254 1442 2254 1216
Western : Manakalya, 4 <sup>th</sup> Floor, NTH Complex (W Sector), F-10, MIDC, Andheri (East), Mumbai 400093	{ 283 25838

**Branches :** AHMEDABAD, BENGALURU, BHOPAL, BHUBANESHWAR, CHANDIGARH, CHENNAI, COIMBATORE, DEHRADUN, DELHI, FARIDABAD, GHAZIABAD, GUWAHATI, HARYNA, HUBLI, HYDERABAD, JAIPUR, JAMMU & KASHMIR, JAMSHEDPUR, KOCHI, KOLKATA, LUCKNOW, MADURAI, MUMBAI, NAGPUR, NOIDA, PARWANOO, PATNA, PUNE, RAIPUR, RAJKOT, SURAT, VIJAYAWADA.