

पॉलीकार्बोनेट संचकन और बहिर्वेधन  
सामग्री — विशिष्टि

( पहला पुनरीक्षण )

Polycarbonate Moulding and  
Extrusion Materials — Specification

( First Revision )

ICS 83.080.20

© BIS 2023



भारतीय मानक ब्यूरो  
BUREAU OF INDIAN STANDARDS  
मानक भवन, 9 बहादुर शाह ज़फर मार्ग, नई दिल्ली - 110002  
MANAK BHAVAN, 9 BAHADUR SHAH ZAFAR MARG  
NEW DELHI - 110002  
[www.bis.gov.in](http://www.bis.gov.in) [www.standardsbis.in](http://www.standardsbis.in)

May 2023

Price Group 11

## FOREWORD

This Indian Standard (First Revision) was adopted by the Bureau of Indian Standards, after the draft finalized by the Plastics Sectional Committee had been approved by the Petroleum, Coal and Related Products Division Council.

Polycarbonate has established itself as one of the most versatile engineering thermoplastic materials. This versatility of polycarbonate emanates from excellent combination of mechanical strength, temperature resistance, electrical insulation, optical clarity, wide usability temperature ranges and for its virtual unbreakability. Industries those are being catered by polycarbonate for variety of application include automobile, business machines, electrical and electronics, lighting, telecommunication, appliances, safety and security, food and medical, leisure and building and construction.

The major changes in this revision are:

- a) Requirement for Charpy impact strength, notched has been included in place of Izod impact strength;
- b) Test methods and test Specimen condition have been updated for the determination of flexural modulus and deflection temperature under load; and
- c) Test method for the determination of ash content and optical requirements have been modified.

Performance of parts moulded from polycarbonate is affected by adoption of improper processing techniques, therefore code of good processing practices of polycarbonate in this standard has been included (*see* Annex B).

Assistance has been derived from the following publications while preparing this standard:

ISO 21305-1 : 2019 Plastics — Polycarbonate (PC) moulding and extrusion materials — Part 1: Designation system and basis for specification

ISO 21305-2 : 2019 Plastics — Polycarbonate (PC) moulding and extrusion materials — Part 2: Preparation of test specimens and determination of properties

For the test method on flammability requirements, assistance has been derived from UL 94.

The composition of the committee responsible for the formulation of this standard is listed in Annex E.

For the purpose of deciding whether a particular requirement of this standard is complied with, the final value, observed or calculated, expressing the result of a test or analysis shall be rounded off in accordance with IS 2 : 2022 'Rules for rounding off numerical values (*second revision*)'. The number of significant places retained in the rounded off value should be the same as that of the specified value in this standard.

*Indian Standard*  
**POLYCARBONATE MOULDING AND EXTRUSION  
 MATERIALS — SPECIFICATION**

( *First Revision* )

## 1 SCOPE

**1.1** This standard covers the requirements, methods of sampling and tests for both polycarbonate homo-polymer, co-polymers and high-heat polymers. It applies to unmodified materials ready for normal use and materials modified for example, by colourants, additives, fillers, reinforcing materials and polymer modifiers, suitably compounded to ensure desired performance of the parts manufactured from it by any of the usual processing techniques like injection moulding, extrusion, blow moulding, compression moulding etc.

**1.2** This standard establishes a system for designating various possible polycarbonate materials. Since the system is not based on application, part design and performance requirements, it cannot be used for selection of a polycarbonate material for specific use. For selection of material for specific use, experts well versed with the application, part design, performance requirements, materials and processing techniques should be consulted. Similarly, the code of good processing practices covered in this standard is intended to act as a guide to the processing community. For specific application and material, expert opinion should be sought for part and mould design, machine selection and processing parameters.

**1.3** The classification system for types of polycarbonate plastics is differentiated from each other by a classification system based on appropriate levels of the designatory properties:

- a) Melt volume-flow rate; and
- b) Charpy notched impact strength; and

upon information about the intended application and/or method of processing technique, important properties, additives, colorants, fillers and reinforcing materials.

**1.4** This standard is applicable only to virgin polycarbonate material and does not cover polycarbonate blends and alloys.

## 2 REFERENCES

The standards listed in Annex A contain provisions which, through reference in this text, constitute provision of this standard. At the time of publication, the edition indicated were valid. All standards are subject to revision, and parties to agreements based on this standard are encouraged to investigate the possibility of applying the most recent editions of the standards listed in Annex A.

## 3 TERMINOLOGY

For the purpose of this standard, the definitions given in IS 2828 shall apply.

## 4 DESIGNATION/CLASSIFICATION SYSTEM

### 4.1 General

**4.1.1** Designation code for polycarbonate material shall be done based on five data blocks. The designation shall consist of following information given in the order presented and shall be codified in different blocks as indicated below:

Data Block 1	For Indian Standard
Data Block 2	For material and fillers
Data Block 3	For processing technique, important properties, additives and supplementary information
Data Block 4	For designatory properties
Data Block 5	For any additional requirement

**4.1.2** Each data block shall be separated by space or hyphen.

**4.1.3** If a data block is not used, this shall be indicated by double comma (,,).

**4.1.4** In case of data block 5, as it is for additional information, if no information is to be specified, double comma (,,) may or may not be used.

## 4.2 Designation System Codification

**4.2.1 Data Block 1** — For Indian Standard.

### 4.2.2 Data Block 2

**4.2.2.1** This data block is used to describe the thermoplastic material under consideration. Four letters and two digits are used for this purpose. First two letters 'PC' indicates the material under designation. Succeeding two letters indicate the type and form of reinforcement or filler present and last two digits indicates level of addition of the reinforcement or filler. The codes regarding the reinforcement/filler and the level of addition are given in Table 1 and 2 respectively. In case of unfilled material, the two letters and two digits succeeding 'PC' shall be expressed by use of four 'X'.

**4.2.2.2** For a 20 percent glass fibre filled polycarbonate material, block 2 shall be represented by PCGF20. Percentage of any inorganic filler/reinforcement shall be derived by method described in IS 13360 (Part 8/Sec 8) of this standard at temperature of 800 °C to 850 °C.

### 4.2.3 Data Block 3

**4.2.3.1** This data block accommodates four letters. The first letter indicates the processing technique for which the material is suitable. The other three letters indicate presence of specific additives, colours and any specific feature of the material. If any of the information is not relevant in this block, the same shall be represented by a "X". The codes for processing techniques and for additives and feature are given in Table 3.

**4.2.3.2** A general purpose light stabilized polycarbonate material containing mould release additives and in natural colour shall be represented in block 3 as GLRN.

### 4.2.4 Data Block 4

**4.2.4.1** This data block consists of 5 digits. Each digit indicates the following properties in order:

- a) Melt volume-flow rate (MVR) for standard polycarbonate to be measured at 300 °C under 1.2 kg load and for high heat polycarbonate to be measured at 330 °C under 2.16 kg load as per IS 13360 (Part 4/Sec 1/Subsec 1) or IS 13360

(Part 4/Sec 1/Subsec 2) when measured after pre-drying of the material at  $(120 \pm 5)$  °C (effective) for not less than 4 h. Codes for various levels of melt volume-flow rate (MVR) are given in Table 4.

- b) Specific gravity of the material when measured as per IS 13360 (Part 3/Sec 10) or IS 13360 (Part 3/Sec 11) or IS 13360 (Part 3/Sec 12). Codes are given in Table 5.
- c) Flexural modulus of the material when measured as per IS 13360 (Part 5/Sec 7) with a crosshead of 2 mm/min with a support span of 64 mm. Test Specimen used shall be 4 mm in depth and 10 mm in width. Codes are given in Table 5.
- d) Charpy impact strength, notched, when measured as per IS 13360 (Part 5/Sec 5) with test Specimen thickness of 4 mm and a notch radius of 0.25 mm. Codes are given in Table 5.
- e) Deflection temperature measured under load for flexural stress of 1.82 MPa, when tested as per IS 1330 (Part 6/Sec 3) using a 4 mm thick test specimen. Codes are given in Table 5.

**4.2.4.2** If any of the above properties are not to be specified or not available, a "X" mark shall be indicated in the block at appropriate position. Designation of Melt volume-flow rate (MVR) and Charpy impact strength, notched shall be indicated.

**4.2.4.3** For a polycarbonate material with MVR between 3 to 6, specific gravity of 1.25, flexural modulus of 3 700 MPa, Charpy impact strength, notched of 92 kJ/m<sup>2</sup> and deflection temperature under load of 143 °C, block 4 will look like B2265.

### 4.2.5 Data Block 5

**4.2.5.1** This data block is provided for any additional specific performance requirement if required to be specified. These specific performances include electrical, flammability and optical requirements. In case, there is no specific requirement for the material the designation ends at block 4.

**4.2.5.2** Each requirement is codified by a combination of one letter and two digits. The letter indicates the requirement; the subsequent digit

indicates the thickness of the test specimen, and the last digit indicates the specified properties. The scheme is elaborated below:

E = Electrical requirement

First digit

- 0 = Specimen thickness to be decided mutually by user and supplier; and
- 1 = Specimen thickness 3.2 mm nominal.

Second digit

- 0 = Properties to be decided mutually by user and supplier;
- 1 = Electrical properties conform with property limit mentioned in Table 6 col (4); and
- 2 = Electrical properties conform with property limit mentioned in Table 6 col (5).

NOTE — Though the above system is infinitely flexible and can be used theoretically to express any desired combination, the user should keep in mind that certain combinations are not practical, and the buyer and seller should mutually agree before specifying any unusual combination.

F = Flammability requirements in accordance with Annex C of this standard

First digit

- 0 = Specimen thickness to be decided mutually by user and supplier;
- 1 = Test Specimen thickness 6.10 mm maximum;
- 2 = Test Specimen thickness 3.05 mm maximum; and

- 3 = Test Specimen thickness 1.47 mm maximum.

Second digit

- 0 = Flammability class to be decided mutually by the user and supplier;
- 1 = UL 94 HB Flammability class;
- 2 = UL 94 V2 Flammability class;
- 3 = UL 94 V1 Flammability class;
- 4 = UL 94 VO Flammability class; and
- 5 = UL 94 5V Flammability class.

NOTE — This does not intend that above flammability rating by any way reflects hazards presented under actual fire conditions.

T = Optical requirements in accordance with IS 13360 (Part 9/Sec 5) of this standard

First digit

- 0 = Specimen thickness to be decided mutually by user and supplier;
- 1 = Specimen thickness 6.4 mm nominal;
- 2 = Specimen thickness 3.2 mm nominal; and
- 3 = Specimen thickness 1.6 mm nominal.

Second digit

- 0 = Percentage transmittance to be mutually decided by user and supplier
- 1 = Minimum 88 percent transmittance;
- 2 = Minimum 85 percent transmittance; and
- 3 = Minimum 82 percent transmittance.

**Table 1 Codes for Filler/Reinforcement for Data Block 2**  
(Clause 4.2.2.1)

Sl No.	Code	Material (Position 3)	Code	Form (Position 4)
(1)	(2)	(3)	(4)	(5)
i)	C	Carbon	B	Ball/Beads/Spheres
ii)	G	Glass	P	Powder
iii)	T <sup>1)</sup>	Mineral	F	Fibre
iv)	M <sup>1)</sup>	Metal	G	Ground
v)	O	Others	W	Whisker
vi)	X	Not Specified	S	Scale/Flakes
vii)	-	-	O	Others
viii)	-	-	X	Not Specified

1) The material can be specified after the full designation of polycarbonate by chemical name or symbol.

**Table 2 Codes for Percentage Content of Filler/Reinforcement for Data Block 2**  
(Clause 4.2.2.1)

SI No.	Code	Content by Mass, Percent ( Position 5 and 6 )
(1)	(2)	(3)
i)	05	≤ 7.5
ii)	10	> 7.5 to 12.5
iii)	15	> 12.5 to 17.5
iv)	20	> 17.5 to 22.5
v)	25	> 22.5 to 27.5
vi)	30	> 27.5 to 32.5
vii)	35	> 32.5 to 37.5
viii)	40	> 37.5 to 42.5
ix)	45	> 42.5 to 47.5
x)	50	> 47.5 to 55
xi)	60	> 55.0 to 65
xii)	70	> 65.0 to 75
xiii)	80	> 75.0 to 85
xiv)	90	> 85.0

**Table 3 Codes for Processing Techniques and Additives for Data Block 3**  
(Clause 4.2.3.1)

SI No.	Code	Position	Code	Position 2 to 4
(1)	(2)	(3)	(4)	(5)
i)	B	Blow moulding	C	Coloured
ii)	E	Extrusion	E	Expandable
iii)	I	Injection moulding	F	Flame retardant
iv)	C	Compression moulding	H	Heat stabilized
v)	O	Optical disc moulding	L	Light and/or weather stabilized
vi)	R	Rotational moulding	M	Food and medical approved
vii)	G	General purpose	N	Natural ( not coloured)
viii)	X	No indication	P	Impact modified
xi)	-	-	R	Mould release agent
x)	-	-	T	Improved transparency
xi)	-	-	W	Stabilized against hydrolysis
xii)	-	-	Y	Increased electrical conductivity
xiii)	-	-	Z	Antistatic

**Table 4 Codes for Block 4**  
[Clause 4.2.4.1, Sl No. (a)]

SI No.	Code	Melt Volume-Flow Rate (MVR), cc/10 min,	
		300 °C, 1.2 kg load	330 °C, 2.16 kg load
(1)	(2)	(3)	(4)
i)	A	≤ 3	≤ 3
ii)		> 3 to 6	
	B		> 3 to 6
iii)	C	> 6 to 12	> 6 to 12
iv)	D	>12 to 24	> 12 to 24
v)	E	> 24	> 24

**Table 5 Codes for Block 4**  
[Clause 4.2.4.1, Sl No. (b), (c), (d) and (e)]

SI No.	Code	Specific Gravity	Code	Flexural Modulus, MPa, <i>Min</i>	Code	Charpy Impact Strength, Notched, kJ/m <sup>2</sup>	Code	Deflection Temperature Under 1.82 MPa Load, °C, <i>Min</i>
(1)	(2)	(3)	(4)	(5)	(6)	(7)	(8)	(9)
i)	1	1.19 to 1.22	1	2 000	1	≤ 10	1	120
ii)	2	> 1.22 to 1.3	2	3 000	2	> 10 to 30	2	125
iii)	3	> 1.3 to 1.38	3	4 500	3	>30 to 50	3	130
iv)	4	> 1.38 to 1.50	4	6 000	4	>50 to 70	4	135
v)	5	> 1.50	5	7 500	5	>70 to 90	5	140
vi)			6	9 000	6	>90	6	145
vii)			7	10 500			7	150
viii)			8	12 000			8	155
ix)	X	No indication	X	No indication			X	No indication

**Table 6 Electrical Properties of Unreinforced Polycarbonate Materials for Block 5**  
(Clause 4.2.5.2)

SI No.	Property	Requirement		Test Method, Ref to
		Unreinforced Polycarbonate	Reinforced Polycarbonate	
(1)	(2)	(4)	(5)	(6)
i)	Volume resistivity, <i>Min</i> , ohm-cm	$1 \times 10^{15}$	$1 \times 10^{14}$	IS 3396
ii)	Dielectric strength, <i>Min</i> , kV/mm	14	15	
iii)	Dielectric constant at 1 MHz, <i>Max</i>	3	3.7	IS 4486
iv)	Dissipation factor at 1 MHz, <i>Max</i>	0.01	0.015	

### 4.3 Examples of Designation System

*Example 1 : Designation Code:* IS 14434-PCGF10-ILRC-B2265-F34

IS	PCGF10	ILRC	B2265	F34
Block 1 (Indian Standard)				
Block 2 [Glass fibre filled (between 7.5 percent to 12.5 percent) polycarbonate]				
Block 3 (Suitable for injection moulding, light stabilized contains mould release agent and colours)				
Block 4 (MVR between 3 to 6, specific gravity between 1.22 to 1.3, flexural modulus of 3 000 MPa, <i>Min</i> ; Charpy impact strength, Notched of 92 kJ/m <sup>2</sup> , <i>Min</i> and DTUL of 140 °C, <i>Min</i> )				
Block 5 (Meets UL 94 V-0 flammability class at 1.47 <i>Max</i> sample thickness)				



Example 2 : **Designation Code:** IS 14434-PCXXXX-BMWN-B1124-., or  
IS 14434-PCXXXX-BMWN-B1124

<b>IS</b>	<b>PCXXXX</b>	<b>BMWN</b>	<b>B1124</b>	”
Block 1 (Indian Standard)				
Block 2 (Unfilled polycarbonate material)				
Block 3 (Suitable for blow moulding, food and medical approved, stabilized against hydrolysis and natural in colour )				
Block 4 (MVR between 3 to 6, specific gravity between 1.19 to 1.22, flexural modulus of 2 000 MPa, <i>Min</i> ; Charpy impact strength-notched of 60 kJ/m <sup>2</sup> , <i>Min</i> and DTUL of 135 °C, <i>Min</i> )				
Block 5 No additional requirement				

## 5 REQUIREMENTS

### 5.1 Melt Volume-Flow Rate (MVR)

The melt volume-flow rate (MVR) of the material shall be designated as per Table 4, based on the value as agreed between purchaser and supplier. It shall be determined at 300 °C under 1.2 kg load for standard polycarbonate and at 330 °C under 2.16 kg load for high-heat polycarbonate as per IS 13360 (Part 4/Sec 1/Subsec 1) or IS 13360 (Part 4/Sec 1/Subsec 2) when measured after pre-drying of the material at  $(120 \pm 5)$  °C (effective) for not less than 4 h.

### 5.2 Specific Gravity

The specific gravity of the material shall be designated as per Table 5, based on the value as agreed between purchaser and supplier. It shall be determined as per IS 13360 (Part 3/Sec 10) or IS 13360 (Part 3/Sec 11) or IS 13360 (Part 3/Sec 12).

### 5.3 Flexural Modulus

The flexural modulus of the material shall be designated as per Table 5, based on the value as agreed between purchaser and supplier. It shall be determined as per IS 13360 (Part 5/Sec 7) with a crosshead of 2 mm/min with a support span of 64 mm. Test Specimen used should be 4 mm in depth and 10 mm in width.

### 5.4 Charpy Impact Strength, Notched

The Charpy impact strength, notched of the material shall be designated as per Table 5, based on the value as agreed between purchaser and supplier. It shall be determined as per 13360 (Part 5/Sec 5) with test Specimen thickness of 4 mm and a notch radius of 0.25 mm.

### 5.5 Deflection Temperature Under 1.82 MPa Load

The deflection temperature under 1.82 MPa load of the material shall be designated as per Table 5, based on the value as agreed between purchaser and supplier. It shall be determined as per IS 13360 (Part 6/Sec 3) using a 4 mm thick test specimen.

### 5.6 Special Requirements of Polymer Used for Molding or Extrusion Articles in Contact with Food Stuffs, Pharmaceutical and Drinking Water

**5.6.1** When the products are used in contact with foodstuffs, pharmaceuticals and drinking water, its requirements with respect to the material shall also meet the following:

#### 5.6.1.1 Pigments and colourants

In case the coloured material is used for food-packaging applications it shall comply with the list and limits of the pigments and colourants prescribed in IS 9833.

### 5.6.1.2 Overall migration

The material shall comply with the overall migration limits as detailed below when tested by the method prescribed in IS 9845.

- a) 60 mg/kg, *Max* of the foodstuff; in the case of liquid foodstuffs or of simulants, the limit shall be 60 mg/l, *Max*. However, the value of the overall migration limit shall be equal to 10 mg/dm<sup>2</sup> of the surface of the material or article in the following cases:
  - 1) Containers or articles which are similar to containers or which in any case may be filled to a capacity less than 250 ml, provided it is possible to calculate the surface area of contact with the foodstuff.
  - 2) Sheets, foils and other non-fillable articles for which ratio between the surface area of the material or article and the quantity of foodstuffs, in contact may not be calculated.

### 5.6.1.3 Storage and control

#### 5.6.1.3.1 Storage

Plastics materials intended for food contact use shall be stored separately from materials in closed, properly identified containers.

#### 5.6.1.3.2 Control

An authorized person shall supervise and control the issue of plastics materials to the process or manufacturing area and shall maintain appropriate records of the issue of such materials.

5.6.1.3.3 Adequate standards of hygiene (*see* IS 2491) shall be maintained at all times and plant operators and store men shall be trained in proper hygiene practices.

5.6.2 The requirements mentioned in 5.6.1 will remain valid as long as the chemical composition and manufacturing process remains the same. In case of any change in chemical composition and/or manufacturing processes, the requirements mentioned in 5.6.1 shall be tested.

## 6 PREPARATION OF TEST SPECIMENS

Test specimens for properties mentioned in (c) to (e) of 4.2.4.1 are to be made in accordance with IS 13360 (Part 2/Sec 3).

## 7 CONDITIONING OF TEST SPECIMEN AND CONDITIONS FOR TESTS

All test specimens are to be conditioned for a minimum period of 48 h at  $(27 \pm 2)$  °C under  $(65 \pm 5)$  percent relative humidity and the tests are also to be carried under same conditions.

## 8 PACKAGING AND MARKING

### 8.1 Packing

Packaging should usually be the standard packaging adopted by the supplier unless otherwise agreed with the buyer. Packaging must ensure adequate protection of the content from contamination and loss of material. Mass of the packages should usually be 25 kg nominal unless otherwise agreed between the buyer and the supplier.

### 8.2 Marking

8.2.1 Each package shall be securely closed and legibly and indelibly marked with the following information:

- a) Indication of the source of manufacture and recognized trademark, if any;
- b) Name and designation of the material;
- c) Net mass;
- d) Date of manufacture;
- e) Batch No. or Code No; and
- f) Any other statutory requirements.

### 8.2.2 BIS Certification Marking

The product(s) conforming to the requirements of this standard may be certified as per the conformity assessment schemes under the provisions of the *Bureau of Indian Standards Act, 2016* and the Rules and Regulations framed thereunder, and the products may be marked with the Standard Mark.

## 9 SAMPLING

Unless otherwise agreed upon between the user and the supplier, the materials shall be sampled in accordance with Annex D. Adequate statistical sampling shall be considered as an acceptable alternative. A lot of resin shall be considered as a unit of manufacture as prepared for shipment and may consist of a blend of low or more production runs or batches of material.

## 10 CRITERIA FOR CONFORMITY

**10.1** Each of the test results for melt flow index, notched Charpy impact strength and other applicable characteristics shall satisfy the corresponding requirements given in **5.1** to **5.5**.

**ANNEX A**  
(Clause 2)

**LIST OF REFERRED STANDARDS**

<i>IS No.</i>	<i>Title</i>	<i>IS No.</i>	<i>Title</i>
IS 2491 : 2013	Food hygiene — General principles — code of practice ( <i>third revision</i> )	(Part 3/Sec 11) : 2021/ISO 1183-2 : 2019	Section 11 Determination of density of non-cellular plastics — Density gradient column method ( <i>first revision</i> )
IS 4905 : 2015/ISO 24153 : 2009	Random Sampling and Randomization Procedures ( <i>first revision</i> )	(Part 3/Sec 12) : 2016/ISO 1183-3 : 1999	Section 12 Determination of density of non-cellular plastics — Gas pycnometer method
IS 9833 : 2018	List of pigments and colourants for use in plastics in contact with foodstuffs, pharmaceuticals and drinking water ( <i>second revision</i> )	(Part 4/ Sec 1/Subsec 1) : 2018/ISO 1133-1 : 2011	Rheological properties, Section 1 Determination of the melt mass — Flow rate (MFR) and the melt volume — Flow rate (MVR) of thermoplastics, Subsection 1 Standard method ( <i>first revision</i> )
IS 9845 : 1998	Determination of overall migration of constituents of plastics materials and articles intended to come in contact with foodstuffs — Method of analysis ( <i>second revision</i> )	(Part 4/Sec 1/Subsec 2) : 2014/ISO 1133-2 : 2011	Rheological properties, Section 1 Determination of the melt mass — Flow rate (MFR) and the melt volume — Flow rate (MVR) of thermoplastics, Subsection 2 Method for materials sensitive to time-temperature history and/or moisture ( <i>first revision</i> )
IS 13360	Plastics — Methods of testing:	(Part 5/Sec 5) : 2017/ISO 179-1 : 2010	Mechanical properties, Section 5 Determination of charpy impact properties — Non-instrumented impact test ( <i>first revision</i> )
(Part 2 /Sec 3) : 2019/ISO 294-1 : 2017	Sampling and preparation of test specimens, Section 3 Injection moulding of test specimens of thermoplastic materials — General principles and moulding of multipurpose and bar test specimens ( <i>first revision</i> )	(Part 5/Sec 7) : 2022/ISO 178 : 2019	Mechanical properties, Section 7 Determination of flexural properties ( <i>second revision</i> )
(Part 3/Sec 10) : 2021/ISO 1183-1 : 2019	Physical and dimensional properties, Section 10 Determination of density of non-cellular plastics immersion method liquid pycnometer method and titration method ( <i>first revision</i> )		

<i>IS No.</i>	<i>Title</i>	<i>IS No.</i>	<i>Title</i>
(Part 6/Sec 3) : 2022/ISO 75-1 : 2020	Thermal properties, Section 3 Determination of temperature of deflection under load — General test method ( <i>third revision</i> )		Determination of ash — General methods ( <i>second revision</i> )
(Part 8/Sec 8) : 2021/ISO 3451- 1 : 2019	Permanence/Chemical properties, Section 8	(Part 9/Sec 5) : 1999	Optical properties, Section 5 Determination of haze and luminous transmittance of transparent plastics

## ANNEX B

(Foreword)

## CODE OF GOOD PROCESSING PRACTICES

**B-1** Improper processing and design considerations many a times lead to disastrous results which are not expected from polycarbonate. This code of good processing practices highlights the areas-of critical importance in processing and tool design without any pretension of a full-scale guide to moulding of polycarbonate. It is strongly advised that experts especially the raw material supplier should always be consulted for every aspect of product design, tool design and finally processing of polycarbonate.

**B-2 PRE-DRYING**

**B-2.1** Polycarbonate materials do not absorb much moisture, but presence of moisture beyond 0.02 percent level in polycarbonate is enough to cause hydrolytic polymer chain degradation at processing temperature resulting in highly brittle product. To avoid this eventuality, it is essential to pre-dry any polycarbonate material effectively at  $(120 \pm 5) ^\circ\text{C}$  for at least 4 h. Effect of pre-drying time at  $(120 \pm 5) ^\circ\text{C}$  on moisture content and impact strength is depicted in Fig. 1 and Fig. 2 respectively.

**B-2.2** Pre-drying of polycarbonate granules can be carried out in any of the following type of dryers:

- a) Air circulating oven;
- b) Forced air circulating dryer; and
- c) Dry air circulating dryer.

In the first case the depth of granules on the tray should not exceed 2.5 cm. Enough space should be maintained between trays to allow adequate air circulation. In any of the above drying arrangement cleanliness is very important to avoid unwarranted material contamination.

**B-2.3** Effectiveness of pre-drying on moisture content can be checked by a very easy test

commonly known as ‘Thomasetti’s Volatile Indicator’ (TVI). In this test two microscope slides are placed on a hot plate and allowed to be heated up to  $290 ^\circ\text{C}$  (the temperature is checked with a surface pyrometer). At least four granules from dryer are placed on the slide keeping some distance between each. Immediately the granules are covered with the other slide and the slides are pressed together with a straight edge till the granules are compressed to about 12 mm diameter. Moisture is indicated by the presence of bubbles in the flattened granules. A few small bubbles denote moisture content of between 0.02 percent to 0.03 percent, numerous bubbles between 0.05 percent to 0.1 percent and many large bubbles above 0.1 percent. It should be noted that presence of one or two small bubbles in only one or two granules indicate trapped air rather than presence of moisture.

**B-3 PROCESSING**

**B-3.1** Polycarbonate can be processed into useful end products by any of the usual processing techniques like extrusion, blow moulding, injection moulding etc. Selection of processing equipment, processing conditions and tool designing plays extremely important part in achieving best possible performance in end products made up of polycarbonate.

**B-3.2 Selection of Equipment****B-3.2.1 Extruder**

Extruded polycarbonate sheets and profiles find variety of applications. Use of twin screws extruder is to be avoided. Detailed geometry of single screw extruders without and with venting that should be selected for processing of polycarbonate is given in Table 7.

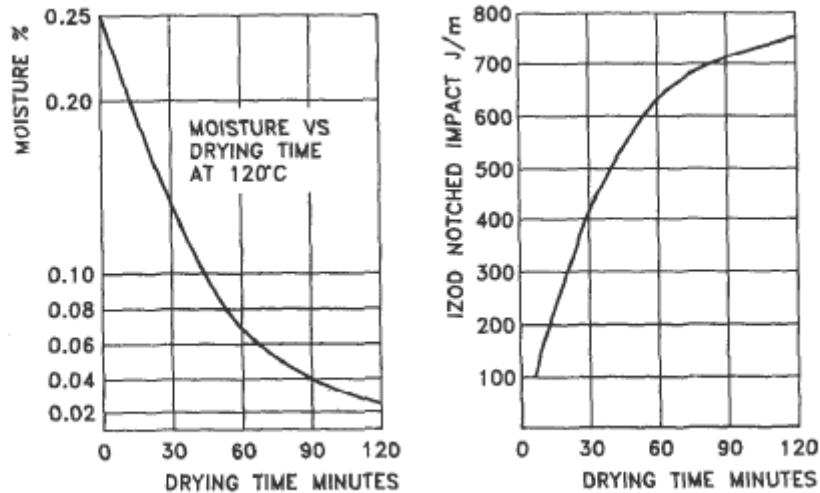

FIG. 1 AND FIG. 2 EFFECT OF DRYING ON POLYCARBONATE

**Table 7 Geometry of Single Screw Extruders**  
(Clause B-3.2.1)

SI No.		3-Zone Unvented	6-Zone Vented
(1)	(2)	(3)	(4)
i)	Feeding	6 - 8 D	5 - 7 D
ii)	Compression	4 - 5 D	4 - 5 D
iii)	Metering	11 - 13 D	4 - 5 D
iv)	L/D ratio	21 - 26 D	-
v)	Compression ratio	1 : 2.5 - 2.8	1 : 2.5 - 2.8
vi)	Venting	-	4D
vii)	Compression	-	3 - 4 D
viii)	Metering	-	8 - 10 D
ix)	L/D ratio	-	28 - 35 D
x)	Compression ratio	-	1 : 2.1 - 2.3

Grooved barrel improves better material transportation, but care should be taken so that high shear does not lead to material overheating. Hopper block should preferably be sealed to prevent moisture pick up. To control feed and avoid premature melting, water cooling should be provided in the hopper block.

Heating of extruder barrel should be achieved by resistance heater band. Control system should be able to maintain close tolerance of  $\pm 2$  °C up to at least 350 °C. Thermostatically controlled air blower and deep probe thermocouples should be used for this purpose.

Like for any other plastic material, breaker

plate/filter assembly has to be used for polycarbonate extrusion to achieve better compression, melting and homogenization. This helps in eliminating contamination and reducing fisheyes. Filter combination of 40-60/100-120/40-60 mesh is preferred.

Drive power requirement for single screw extruder suitable for polycarbonate extrusion is usually in the range of 0.2 kWh/kg to 0.3 kWh/kg output as it depends on melt temperature, viscosity and screw geometry. Power required for polycarbonate extrusion in single screw extruder with different screw diameters is given in Table 8.

**Table 8 Power Requirement**  
(Clause B-3.2.1)

SI No.	Screw Diameter, mm	Required Power, kW
(1)	(2)	(3)
i)	45	20-25
ii)	60	25-30
iii)	90	50-60
iv)	120	75-110

An ideal polycarbonate extruder should be equipped with an infinitely variable gear box to allow screw speed adjustment as a calibrating parameter.

### B-3.2.2 Extrusion Blow Moulding

Continuous and intermittent parison extrusion, with or without accumulators, on both single and dual station machines can be used for blow moulding of polycarbonate. To achieve better resin stability, it is advisable to use chrome plated steel barrel instead of nitrided steel. Minimum two heating zones are recommended for shorter barrels while at least three with separate heater bands for connecting flanges are to be used for larger barrels.

High compression mixing screws are to be completely avoided. For good results screws with compression ratio of 2 : 1 to 3 : 1 should be used. The minimum recommended L/D ratio of the extruder screw is 15 : 1.

All heating zones should be precisely controlled, and no unheated gap should exist on the barrel. On-off pyrometer control should be avoided in favour of variable temperature regulator to achieve uniform melt.

Power requirement for the extruder in the blow moulding machine suitable for polycarbonate is in the range of 0.2 kWh to 0.3 kWh for every kg/h of resin. A screw torque of at least 2 700 kg.cm up to 3 600 kg.cm for low screw rpm should be achieved for better results. A typical 21 : 1, L/D ratio screw in the extruder section of a blow moulding machine for polycarbonate should have its zones divided in 7D feed, 9D transition and 5D metering for best results.

### B-3.2.3 Injection Moulding

To injection mould polycarbonate, plunger type machines are positively to be avoided. Screw pre-plasticising type injection moulding machines preferably with medium to high injection pressure

capability usually give satisfactory result. Machines equipped with precise temperature pressure and speed control give optimum productivity and quality parts.

Hourly plasticising capacity of the machine should be adequate to take care of total part weight produced during the hour. Too high capacity may lead to poor strength in the part due to thermal degradation resulted from high residual time of the melt in the barrel. Lower capacity will extend the cycle time, thereby reducing the productivity.

Shot capacity of the injection moulding machine should be at least 20 percent to 30 percent more than the part weight including sprue and runners to avoid incomplete parts. Part weight should also not be lower than 20 percent of the shot capacity to avoid thermal degradation of the melt remaining in the heated machine barrel for longer period of time. The clamping force of the machine is usually decided based on projected area of the part and injection pressure which in turn depends on part intricacies, flow length and thickness of the part. To take an example, a part with 400 cm<sup>2</sup> projected area being moulded at an injection pressure of 1 000 kg/cm<sup>2</sup> will need a machine with minimum clamping force of 200 tons (it is assumed that only 50 percent of injection pressure is actually transmitted into the mould cavity due to pressure drop in flow path).

L/D ratio of the plasticising screw of an injection moulding machine processing polycarbonate should be 20 : 1 and the compression ratio should be in the range of 1 : 2 to 1 : 2.5. Shut-off-valves cause material hang over and consequent thermal degradation resulting in poor quality parts. Short free flow nozzles with a minimum opening of 3 mm are recommended for processing of polycarbonate. Good nozzle temperature control improves part quality and eliminates melt drooling.

Since polycarbonate is used in components of precision engineering applications, dimensional accuracy and high-performance levels have to be assured during production of the parts. Parameters like temperature, pressure and speed influence part quality immensely and they are to be precisely controlled to ensure quality parts. The machine should be able to control the temperature within  $\pm 2$  °C of the settings. Modern injection moulding machines are equipped with microprocessor control and various control options like variable pressure and speed control, cavity pressure regulation, time control, viscosity regulator etc. are available. These are extremely useful in achieving superior part quality and should be preferred whenever possible.



### B-3.3 Dies and Moulds

#### B-3.3.1 Extrusion Dies

Extrusion die must ensure smooth flow of the melt. All possible areas of material hang up must be avoided. To ensure uniform wall thickness of the extruded profile dies with adjustable opening is preferred. In bigger dies segmented temperature control arrangements help in achieving superior quality product. Downstream equipment's in an extrusion line will depend on the profile to be extruded. Equipment supplier and experts are to be consulted in designing the downstream.

#### B-3.3.2 Blow Moulding Dies and Mould

Integrated head which combines the function of head and accumulator in a single unit is preferred for extrusion blow moulding of polycarbonate. Uniform heat distribution and wall thickness control are ensured in this system.

Streamlined dies ensure smooth flow of the melt without any possibility of hang up. To achieve better transparency in the product highly polished die and head should be used.

Die should be equipped with adjustable bushing to achieve parison thickness uniformity. As polycarbonate does not have appreciable die swell characteristics, the die gap should be very close to the final wall thickness of the parison. The die bushing and mandrel should be maintained at the same level. Radii at the orifice should be around 0.5 mm. Die bushing and mandrel should be equipped with separate temperature control to prevent rolling of parison. Die and length should be 10 to 15 times the parison slot width, but generally not exceeding 10 mm. Dark red hot wire cutter or conventional water-cooled thin cutting blade can be used. For strong weld lines, the pinch-off blades should have included angle of  $30^\circ$  to  $45^\circ$  and the blade width should be maintained between 0.05 mm - 0.08 mm (see Fig. 3).

Satisfactory result could be achieved by use of aluminium or beryllium copper alloys for mould construction. However, if very high part quality is desired, steel is the preferred material. Heating and cooling channel should be provided to help speed of production and quality of parts. To eliminate possibility of stress concentration in the part, sharp corners should be avoided in the mould. Minimum radii of 0.25 mm must be incorporated at all corners. Pinch off areas should be generous and deep under cuts should be avoided. Finely roughened mould surface aids in avoiding air entrapment. To achieve maximum pressure at the parting line the mould faces should be relieved.

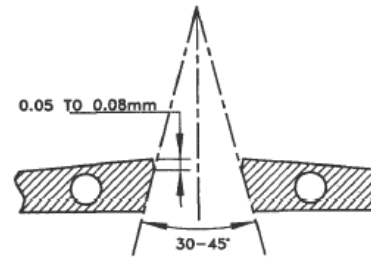

FIG. 3 BLOW MOULD PINCH OFF BLADES

#### B-3.3.3 Injection Moulds

Sprue bushing in an injection mould should have a generous taper, should be well polished and hardened. The sprue diameter should be larger than the nozzle orifice by 1 mm. The sprue bushing radius should be 1 mm larger than that of the nozzle. The small end of the sprue should be at least 4 mm in diameter. In case of direct sprue gating, cooling opposite the sprue avoids sink marks and cooling in the sprue area reduces cycle time.

Short full round primary runners with at least 5 mm diameter are preferred. For long flow path hot runners are recommended. Cold slug wells at the end of both primary and secondary runners must be provided. Trapezoidal runners can be used, if necessary, but half round runners should be avoided.

Gate type, dimension and location depends on the product design and on polycarbonate grade like unreinforced and reinforced and its viscosity. All types of gates, namely pinpoint, diaphragm, film, tunnel, fan, tab, spider, ring, etc could be successfully used for polycarbonate. For unreinforced polycarbonate the pinpoint gate diameter should be between 0.8 mm to 2 mm while the same for reinforced material should be between 1 mm to 2.5 mm. The gate should have very short or no land length. A maximum land length of 0.5 mm to 1 mm is recommended in case of diaphragm gating. In case of tunnel gate, the minimum diameter for unreinforced polycarbonate should be 0.8 mm and the same should be minimum 2 mm for reinforced material. In deciding the location of the gate following points should be kept in mind:

- a) Gate should be placed preferable in the thickest section of the part;
- b) Gate location should minimize weld lines;
- c) Gate should-direct air towards the vents; and
- d) Location should facilitate degating.

Like the sprue, runner and gating the location and design of venting is also important. Improper venting could cause air entrapment in the mould

leading to localized burning, sinks, short shots, high moulded in stress etc. For shallow articles 0.02 mm to 0.05 mm thick vents should be placed at intervals of 2 cm to 4 cm around to cavity periphery which allows venting of air on the split lines opposite the gate. Too much of venting, however, can cause reduction of air speed and can cause blockage and it can also act as potential area for flash. For more complicated and large products venting should be decided based on product and mould design.

To eliminate stress concentration all sharp corners are to be avoided and radii are to be incorporated. For easy removal of part from mould, a draft of approximately  $1/2^\circ$  to  $2^\circ$  per side for both internal and external walls is recommended. In case of complex parts higher draft might be required. In case of textured finish, draft angles should be increased by at least  $1^\circ$  per side for every 0.025 mm of texture depth.

### **B-3.4 Processing Condition**

#### **B-3.4.1 Extrusion**

While extruding flat sheets, depending on the grades of polycarbonate used, the melt temperature should usually be maintained around  $300^\circ\text{C}$  to  $350^\circ\text{C}$ . Temperature of various zones, die and orifice are adjusted accordingly. Die and orifice temperature should be maintained  $5^\circ\text{C}$  to  $10^\circ\text{C}$  lower to the adoper temperature. Calender rolls should be placed as close to the die as possible. Temperature of the rolls should be between about  $130^\circ\text{C}$  to  $160^\circ\text{C}$ . In case of vented barrel extruders which give better extrusion results, however, temperature setting are different and has to be decided based on experience with a particular extruder. In case of other profiles, the conditions depend on grade used and intricacy of the profiles. In polycarbonate extrusion oil cooled screw gives better result especially in terms of elimination of surging.

#### **B-3.4.2 Blow Moulding**

To start the machine, the temperatures should be  $10^\circ\text{C}$  higher than the normal operational level for polycarbonate. This prevents possible damage to the equipment resulting from high back pressure generated through cold melt. Depending on the grade used, the melt temperature should be around  $260^\circ\text{C}$ . Mould temperature of about  $60^\circ\text{C}$  to  $80^\circ\text{C}$  gives good transparency and surface finish as well as shorter cycle time. Since polycarbonate melt does not have the desired elasticity, Parison formation and blowing should be accomplished as rapidly as possible. Top blowing is widely used for products up to 2.1. For larger products, bottom blowing is preferred. Air pressure for blowing should be

maintained between  $1.55\text{ kgf/cm}^2$  to  $3.5\text{ kgf/cm}^2$ . Blow ratios of up to 4 : 1 can be adopted without much problem.

#### **B-3.4.3 Injection Moulding**

The product, mould design and the grade used decide the temperature condition in injection moulding of polycarbonate. Depending on grades used melt temperature between  $240^\circ\text{C}$  to  $350^\circ\text{C}$  has to be achieved to ensure easy moulding and quality product. Mould temperature between  $80^\circ\text{C}$  to  $120^\circ\text{C}$  not only helps in easy flow of melt in the mould and shorter cycle time, but it also ensures stress free moulding with excellent surface finish.

Polycarbonate melt is usually highly viscous and injection pressure requirement is higher as compared to other thermoplastics. Depending on product size, gate dimension and grade used, quite often injection pressure higher than  $1\ 000\text{ kg/cm}^2$  is encountered. After or hold on pressure in case of polycarbonate moulding is about 50 percent of injection pressure. Back pressure should not exceed  $10\text{ kg/cm}^2$ . Like other parameters, injection speed also depends on part intricacies, the mould quality and the gating system. Fast injection speed is, however, desirable to avoid premature freezing of the melt and knitting around corners. Slow injection speed should be used during start up. To facilitate release of part from mould, sometimes use of mould release agent like silicones spray or zinc stearate spray might be required. If, however, the parts need painting or decorating use of release agent should be avoided. These release agents should never be mixed with the polycarbonate granules.

### **B-4 OTHER ASPECTS**

#### **B-4.1 Shut Down and Purging**

Polycarbonate should never be left in the barrel overnight or during weekends. However, for shorter shut down this can be allowed under following precautions:

- a) Barrel temperature is reduced to  $170^\circ\text{C}$  to  $180^\circ\text{C}$ ;
- b) Heaters are kept on; and
- c) Temperature is never allowed to drop below  $160^\circ\text{C}$ .

Below  $160^\circ\text{C}$  polycarbonate tends to adhere to barrel wall and may pull off metal particles and degraded resin as it cools and contracts. Black specs may result in parts when production is restarted after such a temperature drop.

For longer shut down, the barrel should be emptied

completely followed by a thorough purging using scrap acrylic or clear polystyrene. HDPE can also be used. LDPE should, however, be avoided.

#### B-4.2 Recycling

Up to 20 percent of first-generation scrap generated in house, the processing shop can be blended with virgin polycarbonate for processing. However, the cleanliness of the scrap is of utmost importance to achieve quality production. Proper pre-drying of the reground scrap as described for virgin material is also absolutely essential for recycling purpose.

#### B-4.3 Quality Control of Moulded Parts in Polycarbonate by Means of Stress Corrosive Liquids

The aim of quality control of moulded parts should be a reproducible indication for moulded and end user that processing conditions are such that parts of sufficient quality and with required properties are produced.

Causes of an early breakage of a part may include the presence of excessive stresses, due to wrong processing leading to moulded-in stresses, and assembly stresses.

Generally, these stresses cannot be predicted nor calculated, but can be estimated by means of immersion of the moulding in a stress corrosive liquid. These liquids are carefully selected for the different materials to show a stress cracking phenomenon under test conditions at stress levels around the maximum recommended working stresses.

Required liquids for polycarbonate are mixture of toluene and n-propanol in mix ratios (volume) of 1 : 10 and 1 : 3.

It should be emphasized, that these tests have to be carried out in carefully controlled test conditions to ensure reproducibility.

Furthermore, parts subjected to this test but not showing crazes should be destroyed as well, as their expected lifetime has been drastically reduced.

All these tests are destructive. They have to be carried out as spot checks in a statistically justified manner.

Care should be taken not to pollute the liquids with other solvents, which may cause stress cracking as well.

Liquids used daily should be replaced at least once every month.

This test is suitable for all unreinforced regular grades of polycarbonate. A mixture of toluene : n-propanol of 1 : 10 detects a stress level of approximately 20 N/mm<sup>2</sup>. Below this level of polycarbonate part will generally have a sufficient lifetime. For more critical applications, it is advisable to carry out the test with a mixture of toluene : n-propanol of 1 : 3 to detect stress levels higher than 10 N/mm<sup>2</sup>. When testing actual parts, the following procedure should be used:

- a) Choose the appropriate mixture and allow it to come to room temperature;
- b) Immerse the polycarbonate part in the bath for 3 min; and
- c) Lift the part from the bath and rinse it with ethanol or propanol, dry it with compressed air and check it for cracks within 1 min after removal from the bath.

When no cracks are visible the stress level is below the above indicated levels.

#### NOTES

**1** Other solvent or solvent mixtures are described for detecting stress levels in polycarbonate, for example tetrachloromethane and mixtures of ethyl-acetate and methanol. The tetra method is sensitive for stresses even lower than 3N/mm<sup>2</sup> and therefore leads to an unnecessarily severe judgement. Main drawbacks of the ethyl-acetate/methanol mixtures are that ethyl-acetate is absorbed by polycarbonate, so the test solvent should only be used once. Furthermore, the method is very sensitive to temperature and mix-ratio.

**2** Toluene and n-propanol mixtures should be stored in well closed flasks and containers in order to keep the mix ratio constant.

## ANNEX C

(Clause 4.2.5.2)

## TEST FOR FLAMMABILITY

## C-1 GENERAL

**C-1.1** These requirements cover tests for flammability of plastics materials used for parts in devices and appliances. They are intended to serve as a preliminary indication of their acceptability with respect to flammability for a particular application.

**C-1.2** The methods described in this standard involve standard size specimens and are intended to be used solely to measure and describe the flammability properties of materials, used in devices and appliances, in response to heat and flame under controlled laboratory conditions. The actual response to heat and flame of materials depends upon the size and form, and on the end-use of the product using the material. Assessment of other important characteristics in the end-use application includes, but is not limited to, factors such as ease of ignition, burning rate, flame spread, fuel contribution, intensity of burning, and products of combustion.

**C-1.3** The final acceptance of the material is dependent upon its use in complete equipment that conforms with the standard applicable to such equipment. The flammability classification considered for a material may vary, depending on the equipment or device involved and the particular use of the material. The performance level of a material by these methods should not be assumed to correlate with its performance in end-use application.

**C-1.4** The requirements may be applied to other non-metallic materials if found to be appropriate.

**C-1.5** These requirements do not cover plastics when used as materials for building construction of finishing.

## C-2 HORIZONTAL BURNING TEST FOR CLASSIFYING MATERIALS 94HB

## C-2.1 Test Criteria

A material shall be classified 94HB on the basis of test results obtained on small bar specimens when tested as described in C-2.4 to C-2.12.

**C-2.2** A material classed 94HB shall (*see also* C-2.3):

- a) not have a burning rate exceeding 38.1 mm per minute over a 76.2 mm span for specimens having thickness of 3.05 mm - 12.7 mm, or
- b) not have a burning rate exceeding 76.2 mm/min over a 76.2 mm span for specimens having a thickness less than 3.05 mm, or
- c) cease to burn before the flame reaches the 102 mm reference mark (*see* C-2.10).

**C-2.3** If only one Specimen from a set of three specimens does not comply with the requirements, another set of three specimens is to be tested. All specimens from this second set shall comply with the requirements for material in that thickness to be classified 94HB.

## C-2.4 Apparatus

The apparatus employed is to consist of the following:

- a) *Test Chamber* — enclosure, or laboratory hood free of induced or forced draft during tests;
- b) *Laboratory Burner* — A Bunsen or Tirrill burner having a tube with a length of 80 mm to 100 mm and an inside diameter of  $9.4 \frac{+1.6}{-0.0}$  mm. The tube is not to be equipped with an end attachment, such as a stabilizer.
- c) *Wire Gauze* — A 20 mesh (20 openings per 25.4 mm), 0.43 mm diameter iron wire gauze, 127 mm square;
- d) *Gas Supply* — A supply of technical grade methane gas with regulator and meter for uniform gas flow. Natural gas having a heat content of approximately 37 MJ/m<sup>3</sup> has been found to provide similar results. Other fuel gases, such as butane, propane and acetylene (which have a higher heat value) may also be used. However, technical grade methane gas shall be used in case of dispute;
- e) *Ring Stand* — A ring stand with clamps, or the equivalent, for horizontal positioning of the Specimen and the wire gauze;

- f) *Stopwatch* or other timing device;
- g) *Conditioning room or chamber* capable of being maintained at  $(27 \pm 2) ^\circ\text{C}$  and a relative humidity of  $(65 \pm 5)$  percent; and
- h) A *metal support fixture* as illustrated in Fig. 4 for testing specimens that sag or bend at their free end.

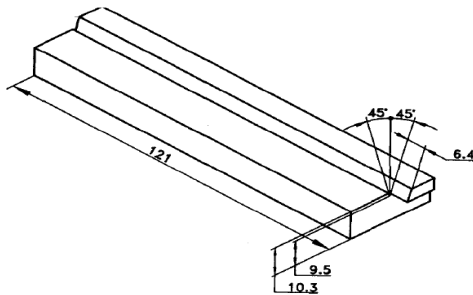

All dimensions in millimetres.  
FIG. 4 FLEXIBLE SPECIMEN SUPPORT FIXTURE

### C-2.5 Test Specimens

Test specimens are to be limited to a maximum thickness of 12.7 mm width are to be provided in the minimum thickness and in a  $(3.18 \pm 0.13)$  mm thickness. The  $(3.18 \pm 0.13)$  mm thick specimens are not necessary if the minimum thickness is greater than  $(3.18 \pm 0.13)$  mm or the maximum thickness is less than  $(3.18 \pm 0.13)$  mm.

*Exception:* A material classified 94HB in the  $(3.18 \pm 0.13)$  mm thickness shall automatically be classed 94 HB down to a 1.57 mm minimum thickness without additional testing.

**C-2.6** The specimens are to comply with the following:

- The maximum width is to be 213.2 mm; and
- The edges are to be smooth, and the radius on the corners is not to exceed 1.3 mm.

**C-2.7** If a material is to be considered in a range of colours, melt flows, or reinforcements, specimens representing these ranges are also to be provided. Specimens in the natural (if used in this colour) and in the most heavily pigmented light and dark colours are to be provided and considered representative of the colour range, if the test results are essentially the same. An additional set of specimens is to be provided in the heaviest organic pigment loading, unless the most heavily pigmented light and dark colours include the highest organic pigment level. When certain colour pigments (for example red, yellow, or the like) are known to have particularly critical effects, they are also to be provided. Specimens in the extremes of the melt flows and

reinforcement contents are to be provided and considered representative of the range, if the test results are essentially the same. If the burning characteristics are not essentially the same for all specimens representing the range, evaluation is to be limited only to the material in the colours, melt flows, and reinforcement contents test, or additional specimens in intermediate colours, melt flows, and reinforcement contents arc to be provided for tests.

### C-2.8 Specimen Conditioning

The specimens are to be conditioned for at least 48 h at  $(27 \pm 2) ^\circ\text{C}$  and a relative humidity of  $(65 \pm 5)$  percent prior to testing.

### C-2.9 Test Method

The burning test is to be conducted in a chamber, enclosure, or laboratory hood free of induced or forced draft. An enclosed laboratory hood with a heat resistant-glass window and an exhaust fan for removing the products of combustion after the test is recommended.

**C-2.10** Each Specimen is to be marked across its width with two lines, 25.4 mm and 102 mm from one end of the specimen. The Specimen is to be clamped at the end farthest from the 25.4 mm mark, with its longitudinal axis horizontal and its transverse axis inclined  $45^\circ$ . The wire gauze is to be clamped horizontally beneath the specimen, with a distance of 9.5 mm between the lowest edge of the Specimen and the gauze, and with the free end of the Specimen even with the edge of the gauze (*see* Fig. 5).

**C-2.10.1** If the Specimen sags at its free end during the initial set up, the support fixture illustrated in Fig. 4 is to be positioned under the Specimen with the small extending portion of the support fixture 19 mm from the free end of the specimen. Enough clearance is to be provided at the clamped end of the Specimen so that the support fixture can be freely moved side-wards. As the flame front progresses along the Specimen the support fixture is to be withdrawn at the same rate.

**C-2.11** The burner is then to be placed remote from the specimen, ignited, and adjusted to produce a blue flame 25 mm high. The flame is to be obtained by adjusting the gas supply and the airports of the burner until a 25 mm yellow tipped blue flame is produced and then the air supply is to be increased until the yellow tip disappears. The height of the flame is to be measured again and corrected if necessary. The flame is to be applied to the free end at the lower edge of the specimen. The centre axis of the burner tube is to be in the same vertical plane as the longitudinal bottom edge of the Specimen (and inclined toward the end of the specimen) at an angle

of approximately 45° to the horizontal (*see* Fig. 5). The flame is to be applied so that the front edge of the specimen, to a depth of approximately 6.4 mm, is subjected to the test flame for 30 s without changing the position of the burner and is then removed from the specimen. If the Specimen burns to the 25.4 mm mark before the flame has been applied for 30 s, the flame application is to be discontinued when the flame reaches the 25.4 mm mark.

**C-2.12** If the Specimen continues to burn after removal of the test flame, the time for the flame front to travel from the mark 25.4 mm from the free end to the mark 102 mm from the free end, is to be determined and the rate of burning is to be calculated.

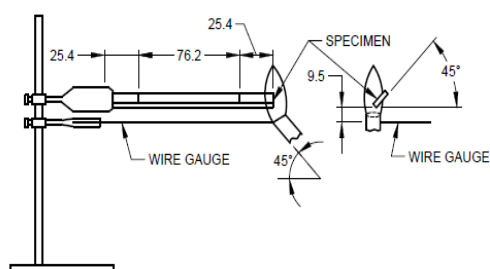

All dimensions in millimetres.

FIG. 5 HORIZONTAL BURNING TEST FOR 94 HB CLASSIFICATION

### C-3 VERTICAL BURNING TEST FOR CLASSIFYING MATERIALS 94V-0, 94V-1 OR 94V-2

#### C-3.1 Test Criteria

Materials shall be classified 94V-0, 94V-1 or 94V-2 on the basis of results obtained on small bar specimens when tested as described in C-3.6 to C-3.15.

**C-3.1.1** Some materials, due to their thinness, distort, shrink, or are consumed up to the holding clamp when subjected to this test. These materials may be tested according to the vertical burning test for classifying materials 94VTM-0, 94VTM-1 or 94VTM-2, provided specimens can be properly formed.

#### C-3.2 Materials Classed 94V-0

A material classed 94V-0 shall not (*see also* C-3.5):

- a) Have any specimens that burn with flaming combustion for more than 10 s after either application of the test flame;
- b) Have a total flaming combustion time exceeding 50 s for the 10 flame applications for each set of five specimens;

- c) Have any specimens that burn with flaming or glowing combustion up to the holding clamp;
- d) Have any specimens that drip flaming particles that ignite the dry absorbent surgical cotton located 305 mm below the test specimen; and
- e) Have any specimens with glowing combustion that persists for more than 30 s after the second removal of the test flame.

#### C-3.3 Materials Classed 94V-1

A material classed 94V-1 shall not (*see also* C-3.5):

- a) Have any specimens that burn with flaming combustion for more than 30 s after either application of the test flame;
- b) Have a total flaming combustion time exceeding 250 s for the flame applications for each set of five specimens;
- c) Have any specimens that burn with flaming or glowing combustion up to the holding clamp;
- d) Have any specimens that drip flaming particles that ignite the dry absorbent surgical cotton located 305 mm below the test specimen; and
- e) Have any specimens with glowing combustion that persists for more than 60 s after the second removal of the test flame.

#### C-3.4 Materials Classed 94V-2

A material classed 94V-2 shall (*see also* C-3.5):

- a) Not have any specimens that burn with flaming combustion for more than 30 s after either application of the test flame.
- b) Not have a total flaming combustion time exceeding 250 s for the 10 flame applications for each set of five specimens.
- c) Not have any specimens that burn with flaming or glowing combustion up to the holding clamp.
- d) Be permitted to have specimens that drip flaming particles that burn only briefly, some of which ignite the dry absorbent surgical cotton placed 305 mm below the test specimen.
- e) Not have any specimens with glowing combustion that persists for more than 60 s after the second removal of the test flame.

**C-3.5** If only one specimen from a set of five specimens does not comply with the requirements, another set of five specimens is to be tested. In the case of the total number of seconds of flaming, an additional set of five specimens is to be tested if the totals are in the range of 51 s - 55 s for 94V-0 and 251 s - 255 s for 94V-1 and 94V-2. All specimens from this second set shall comply with the appropriate requirements for the material in that thickness to be classified 94V-0, 94V-1 or 94V-2.

### C-3.6 Apparatus

The apparatus employed is to consist of the following:

- a) *Test Chamber* — enclosure or laboratory hood free of induced or forced draft during tests.
- b) *Laboratory Burner* — A Bunsen or Tirrill burner having a tube with a length of 80 mm to 100 mm and an inside diameter of  $9.4 \begin{smallmatrix} +1.6 \\ -0.0 \end{smallmatrix}$  mm. The tube is not to be equipped with an end attachment, such as a stabilizer.
- c) *Ring Stand* — A ring stand with clamps or the equivalent, adjustable for vertical positioning of specimens.
- d) *Gas Supply* — A supply of technical grade methane gas with regulator and meter for uniform gas flow. Natural gas having a heat content of approximately 37 MJ/m<sup>3</sup> has been found to provide similar results. However, technical grade methane gas is to be used in case of dispute. Other fuel gases, such as butane, propane, and acetylene have a higher heat content and are not acceptable.
- e) *Stopwatch* or other timing device.
- f) A supply of *dry absorbent surgical cotton*.
- g) A *desiccator* containing anhydrous calcium chloride.
- h) *Conditioning room or chamber* capable of being maintained at  $(27 \pm 2)$  °C and a relative humidity of  $(65 \pm 5)$  percent.
- j) *Conditioning Oven* — A full draft air-circulating oven capable of being maintained at  $(70 \pm 1)$  °C.

### C-3.7 Test Specimens

Test specimens, 127 mm in length by 12.7 mm in width in the minimum and maximum thicknesses are

to be tested covering the thickness range to be considered. Specimens tested by this method are limited to a maximum thickness of 12.7 mm. Specimens in intermediate thicknesses are also to be provided and may be tested if the results obtained on the minimum or maximum thickness indicate a need. Intermediate thicknesses are not to exceed increments of 3.18 mm. The Specimens are to comply with the following:

- a) The maximum width is to be 13.2 mm; and
- b) The edges are to be smooth and the radius on the corners is not to exceed 1.27 mm.

**C-3.8** If the material is to be considered in a range of colours, melt flows, or reinforcements, specimens representing those ranges are also to be provided. Specimens in the natural (if used in this colour) band in the most heavily pigmented light and dark colours are to be provided and considered representative of the colour range, if the burning characteristics are essentially the same. An additional set of specimens is to be provided in the heaviest organic pigment loading, unless the most heavily pigmented light and dark colours include the highest organic pigment level. When certain colour pigments (for example, red, yellow, or the like) are known by experience to have particularly critical effects, they are also to be provided. Specimens in the extremes of the melt flows and reinforcement contents are to be provided and considered representative of the range, if the burning characteristics are essentially the same. If the burning characteristics are not essentially the same for all specimens representing the range, evaluation is to be limited only to the material in the colours, or additional specimens in intermediate colours, melt flows, and reinforcement contents are to be provided for tests.

### C-3.9 Specimen Conditioning

Specimen sets are to be conditioned as follows:

- a) Sets of five specimens each are to be conditioned for at least 48 h at a temperature of  $(27 \pm 2)$  °C and a relative humidity of  $(65 \pm 5)$  percent prior to testing.
- b) Sets of five specimens each are to be conditioned in an air-circulating oven for 168 h at  $(70 \pm 1)$  °C and then cooled in a desiccator, over anhydrous calcium chloride, for at least 4 h at room temperature prior to testing.

*Exception:* As an alternative to 168 h at  $(70 \pm 1)$  °C industrial laminates may be conditioned for 24 h at  $(125 \pm 1)$  °C.

### C-3.10 Test Method

The burning test is to be conducted in a chamber, enclosure, or laboratory hood free of induced or forced draft. An enclosed laboratory hood with a heat resistant glass-window and an exhaust fan for removing the products of combustion after the test is recommended.

**C-3.11** Each Specimen is to be supported from the upper 6.4 mm of the specimen, with the longitudinal axis vertical, by the clamp of the ring stand so that the lower end of the Specimen is 9.5 mm above the top of the burner tube and 305 mm above a horizontal layer of dry absorbent surgical cotton. To form the horizontal layer, a small portion, approximately 12.7 mm × 25.4 mm of cotton is to be pulled from the supply with thumb and forefinger and then thinned and spread with the fingers into a 5.08 mm square having a freestanding thickness of 6.4 mm.

**C-3.12** The burner is then to be placed remote from the specimen, ignited, and adjusted to produce a blue flame 19 mm high. The flame should be obtained by adjusting the gas supply and the airports of the burner until a 19 mm yellow-tipped blue flame is produced and then an increase in the air supply is to be made until the yellow-tip disappears. The height of the flame is to be measured again and corrected, if necessary.

**C-3.13** The test flame is to be placed centrally under the lower end of the test Specimen and allowed to remain for 10 s. The test flame is then to be withdrawn at least 152 mm away and the duration of flaming of the Specimen noted. When flaming of the Specimen ceases, the test flame is to be immediately placed again under the Specimen. After 10 s, the test flame is again to be withdrawn, and the duration of flaming and glowing is to be noted.

**C-3.14** If the Specimen drips molten or flaming material during either flame application, the burner may be tilted to an angle up to 45° and slightly withdrawn from one of the 12.7 mm sides of the Specimen during the flame application, to avoid material dripping into the tube of the burner. If the Specimen drips molten or flaming material or is consumed during the test, the burner is to be handheld, and the 9.5 mm distance between the bottom of the Specimen and the top of the burner tube is to be maintained during the flame application. Any molten strings of the material are to be ignored, and the flame is to be applied to the major portion of the specimen.

**C-3.15** The following are to be observed and

recorded:

- a) Duration of flaming after first flame application;
- b) Duration of flaming after second flame application;
- c) Duration of flaming plus glowing after second flame application;
- d) Whether or not Specimens bum up to the holding clamp; and
- e) Whether or not Specimens drip flaming particles that ignite cotton swatch.

## C-4 VERTICAL BURNING TEST FOR CLASSIFYING MATERIALS 94-5V

### C-4.1 Test Criteria

A material shall be classified 94-5V based on test results obtained on small bar specimens when tested as described in **C-4.5** to **C-4.14**.

**C-4.2** -A material classed 94-5V shall (*see also C-4.4*):

- a) Not have any specimens that burn with flaming or glowing combustion for more than 60 s after the fifth flame; and
- b) Not have any specimens that drip any particles.

**C-4.3** In conjunction with **C-4.2** observation shall be made for destruction of the specimens during and after tests. If any specimens are observed to undergo shrinkage, elongation, melting or the like, additional tests shall be conducted on 152 mm × 152 mm plaques of the same thickness, in accordance with **C-4.15** to **C-4.20**. Tests of plaques shall also comply with **C-4.2**.

**C-4.4** If only one Specimen from a set of five specimens does not comply with the requirements, another set of five specimens are to be tested. All specimens from this second set are to comply with the requirements in order for the material in that thickness to be considered acceptable.

### C-4.5 Apparatus

The apparatus employed is to consist of the following.

- a) *Test Chamber* — enclosure, or laboratory hood free of induced or forced draft during tests;
- b) *Laboratory Burner* — A Tirrill burner having a tube with a length of 80 mm to 100 mm and



an inside diameter of  $9.4 \frac{+1.6}{-0.0}$  mm. The tube shall not be equipped with an end attachment, such as stabilizer;

- c) *Ring Stand* — A ring stand with clamps or the equivalent, adjustable for vertical positioning of specimens.
- d) *Gas Supply* — A supply of technical grade methane gas with regulator and meter for uniform gas flow. Natural gas having a heat content of approximately 37 MJ/m<sup>3</sup> has been found to provide similar results. However, technical grade methane gas is to be used in case of dispute. Other fuel gases, such as butane, propane and acetylene have a higher heat content and are not acceptable.
- e) *Mounting Block* — A block capable of positioning the burner at an angle of 20° from the vertical.
- f) *Stopwatch* or other timing device.
- g) A *desiccator* containing anhydrous calcium chloride.
- h) *Conditioning room or chamber* capable of being maintained at  $(27 \pm 2)$  °C and a relative humidity of  $65 \pm 5$  percent.
- j) *Conditioning Oven* — A full draft air circulating oven capable of being maintained at  $(121 \pm 1)$ °C.

#### C-4.6 Test Specimens and Plaques

Test specimens, 127 mm in length × 12.7 mm in width and test plaques approximately 152 mm × 152 mm are to be tested in a minimum and maximum thicknesses covering the thickness range to be considered. The specimens and plaques tested by this method are limited to a maximum thickness of 12.7 mm. Specimen and plaques in intermediate thicknesses are also to be provided and may be tested if the results obtained on the minimum or maximum thickness indicate a need. Intermediate thicknesses are not to exceed increments of 3.18 mm. The specimens and plaques are to comply with the following:

- a) The maximum Specimen width is to be 13.2 mm; and
- b) The edges are to be smooth and the radius on the comers is not to exceed 1.27 mm

**C-4.7** If the material is to be considered in a range of colours, melt flows, or reinforcement, specimens and plaques representing those ranges are also to be

provided. Specimens and plaques in the natural (if used in this colour) and in the most heavily pigmented light and dark colour are to be provided and be considered representative of the colour range, if the burning characteristics are essentially the same. An additional set of specimens is to be provided in the heaviest organic pigment loading, unless the most heavily pigmented light and dark colours include the highest organic pigment level. When certain colour pigments (for example red, yellow or the like) are known by experience to have particularly critical effects, they are also to be provided. Specimens and plaques in the extremes of the melt flows and reinforcement contents are to be provided and considered representative of the range, if the burning characteristics are essentially the same. If the burning characteristics are essentially the same for all specimens and plaques representing the range, evaluation is to be limited only to the materials in the colours, melt flows, and reinforcement contents tested, or additional specimens and plaques in intermediate colours melt flows, and reinforcement contents are to be provided for tests.

#### C-4.8 Specimen and Plaque Conditioning

The sets of five specimens and/or plaques are to be conditioned as follows:

- a) Each set is to be conditioned for at least 48 h at a temperature of  $(27 \pm 2)$  °C and a relative humidity of  $(65 \pm 5)$  percent prior to testing.
- b) Each set is to be conditioned in a circulating air oven for a duration of 60 days at  $(121 \pm 1)$  °C and then cooled in a desiccator over anhydrous calcium chloride for at least 4 h at room temperature prior to testing. Other temperatures and/or exposures may be selected based on application.

#### C-4.9 Method A, Test of Specimens

The burning test is to be conducted in a chamber, enclosure, or laboratory hood free of induced or forced draft. An enclosed laboratory hood with a heat resistant glass window and an exhaust fan from removing the products of combustion after the test is recommended.

**C-4.10** The test Specimen is to be supported from the upper 6.4 mm of the specimen, with the longitudinal axis vertical, by the clamp on the ring stand. The burner is to be supported on the inclined plane of a mounting block so that the burner tube may be positioned at 20° from the vertical. The narrow edge of the Specimen is to be face the burner (see Fig. 6).

**C-4.11** The burner is to be placed remote from the specimen, ignited, and in a darkened room, adjusted so that when the burner is in a vertical position, the overall height of the flame is 127 mm, and the height of the inner blue cone is 38 mm (see Fig. 6).

**C-4.12** The flame is then to be applied to one of the lower corners of the Specimen at an angle of 20° from the vertical, so that the tip of the blue cone touches the Specimen (see Fig. 6).

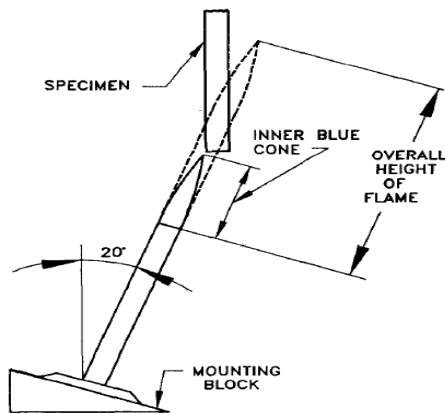

FIG. 6 VERTICAL BURNING TEST FOR 94-5V CLASSIFICATION

**C-4.13** The flame is to be applied for 5 s and removed for 5 s. The operation is to be repeated until the Specimen has been subjected to five applications of the test flame.

**C-4.14** After the fifth removal of the test flame, the following are to be observed and recorded:

- a) Duration of flaming plus glowing;
- b) The distance the Specimen burned or was affected;
- c) Whether or not Specimen dripped particles during test; and
- d) Observations of deformation and physical strength immediately after burning and when cooled.

**C-4.15 Method B, Test of Plaques**

The burning test is to be conducted in a chamber, enclosure, or laboratory hood free of induced or

forced draft. An enclosed laboratory hood with a heat resistant glass window and an exhaust fan for removing the products of combustion after the test is recommended.

**C-4.16** The plaques are to be tested in various positions so that the test flame is applied as follows:

- a) Plaque vertical with the flame applied to lower corner of the plaque;
- b) Plaque vertical with the flame applied to lower edge of the plaque;
- c) Plaque vertical with the flame applied to centre of one side of the plaque;
- d) Plaque horizontal with the flame applied to the centre of the bottom surface of the plaque; and
- e) Plaque horizontal with the flame directed downward to the top surface of the plaque.

**C-4.17** The burner is to be placed remote from the specimen, ignited, and adjusted so that when the burner is in a vertical position, the overall height of the flame is 127 mm, and the height of the inner-blue cone is 38 mm (see also C-4.11).

**C-4.18** The flame is then to be applied to the test plaques in each of the positions given in C-4.16 at an angle of 20° from the vertical, so that the tip of the blue cone, touches the Specimen.

**C-4.19** The flame is to be applied for 5 s and removed for 5 s. The operation is to be repeated until the plaque has been subjected to five applications of the test flame.

**C-4.20** After the fifth removal of the test flame, the following are to be observed and recorded:

- a) Duration of flaming plus glowing;
- b) The distance the plaque burned or was affected;
- c) Whether or not particles dripped from the plaque during the test; and
- d) Observations of deformation and physical strength immediately after burning and when cooled.

**ANNEX D**

(Clause 9)

**SAMPLING OF POLYCARBONATE MOULDING MATERIALS****D-1 GENERAL REQUIREMENTS OF SAMPLING**

**D-1.1** Sample shall not be taken in an exposed place.

**D-1.2** The sampling instrument, which shall be made of glass, stainless steel or any other material on which polycarbonate moulding material has no action, shall be clean and dry.

**D-1.3** Precautions shall be taken to protect the samples, the material being sampled, the sampling instrument and containers selected for sampling from adventitious contamination.

**D-1.4** To draw a representative sample, the contents of each container selected for sampling shall be mixed as thoroughly as possible by suitable means.

**D-1.5** The sample shall be placed in suitable, clean, dry, air-tight sheet metal or glass containers on which the material has no action.

**D-1.6** Each sample container shall be sealed air-tight with a stopper after filling and marked with full details of sampling, the date of sampling and the month and year of manufacture of the material.

**D-2 SCALE OF SAMPLING****D-2.1 Lot**

All the containers in a single consignment of the material drawn from a single batch of manufacture shall constitute a lot. If a consignment is declared or known to consist of different batches of manufacture, the batches shall be marked separately and the groups of containers in each batch shall constitute separate lots.

**D-2.2** A number of containers, consisting of 10 percent of the containers in a lot but not less than 3 containers in any case, shall be selected at random from a lot for the purpose of drawing samples for test (*see* IS 4905).

**D-3 TEST SAMPLES AND REFEREE SAMPLE****D-3.1 Preparation**

To prepare a set of test samples, draw with an

appropriate sampling instrument, from freshly opened containers which have been selected for sampling, an equal number of scoopsfuls of material from any point at least 75 mm below the surface and 75 mm above the bottom of large containers, and from any point at least 25 mm below the surface and 25 mm above the bottom of small containers. The sample prepared by mixing the portions from each container shall not be less than eight times the quantity which is estimated to be required for carrying out all the tests. Divide this composite sample into the required number of reduced samples. Each set of these reduced samples shall constitute the test sample.

**D-3.2** Three sets of test samples, each not less than twice the quantity required for the purpose of testing, representative of each selected container (*see* **D-3.1**) shall be transferred immediately to thoroughly dried containers, which shall be sealed airtight with an appropriate stopper. These containers shall be marked with all the particulars of sampling given under **D-1.6**. One set of the test samples shall be sent to the purchaser and one to the supplier.

**D-3.3 Referee Sample**

The third set of the test samples, bearing the seals of the purchaser and the supplier shall constitute the referee sample, to be used in case of dispute between the purchaser and the supplier. It shall be kept at a place agreed to between the purchaser and the supplier.

**D-4 TEST FOR ACCEPTANCE****D-4.1 Examination and Tests**

The purchaser may examine and test separately samples from each of the lots (*see* **D-2.1**) for compliance with the requirements of the standard, or he may prepare for the purpose of such examination, a composite sample representing the whole of the consignment, by mixing the test samples.

**ANNEX E**  
(Foreword)

**COMMITTEE COMPOSITION**

Plastics Sectional Committee, PCD 12

<i>Organization</i>	<i>Representative(s)</i>
Central Institute of Plastics Engineering & Technology (CIPET), Chennai	PROF (DR) SHISHIR SINHA ( <b>Chairperson</b> ) DR S. N. YADAV ( <i>Alternate I</i> ) DR SMITA MOHANTY ( <i>Alternate II</i> )
All India Plastics Manufacturers Association (AIPMA), New Delhi	SHRI DEEPAK BALLANI
Central Pollution Control Board, New Delhi	MS DIVYA SINHA SHRI C. K. DIXIT ( <i>Alternate</i> )
Chemical and Petrochemical Manufactures Association (CPMA), New Delhi	SHRI UDAY CHAND
Coca - Cola India Pvt Ltd, Gurugram	SHRI VIRENDRA LANDGE SHRI RAJENDRA DOBRIYAL ( <i>Alternate</i> )
Consumer Association of India (CONCERT), Chennai	SHRI G. SANTHANARAJAN SHRI M. R. KRISHNAN ( <i>Alternate</i> )
CSIR-Central Food Technological Research Institute (CFTRI), Mysore	SHRI R. S. MATCHE SHRI KESHA MURTHY. P. ( <i>Alternate</i> )
CSIR-Indian Institute of Toxicological Research (IITR), Lucknow	DR V.P. SHARMA DR A.B. PANT ( <i>Alternate</i> )
CSIR- National Chemical Laboratory (NCL), Pune	DR P. R. SURESHA DR R. V. GUNDLORI ( <i>Alternate I</i> ) SHRIMATI SANGEETA HAMBIR ( <i>Alternate II</i> )
Department of Chemicals & Petrochemicals, Ministry of Chemicals & Fertilizers, New Delhi	SHRI O. P. SHARMA SHRI VARUN SINGH POONIA ( <i>Alternate</i> )
Food Corporation of India (FCI), Delhi	SHRI RAJAGOPAL. A SHRI A. K. U. B. SINGH ( <i>Alternate</i> )
Food Safety and Standards Authority of India (FSSAI), New Delhi	SHRI CHIRAG GADI
GAIL (India) Ltd, Noida	SHRI MANISH KHANDELWAL
Haldia Petrochemicals Ltd, Kolkata	SHRI RAJ K. DATTA SHRI SUVOMOY GANGULY ( <i>Alternate</i> )

<i>Organization</i>	<i>Representative(s)</i>
HMEL, Noida	SHRI VINEET KUMAR GUPTA SHRI ALAKESH GHOSH ( <i>Alternate</i> )
Huhtamaki Paper Product Ltd (HPPL), Hyderabad	SHRI MUTHUSAMY CHOCKALINGAM SHRI AISHWARYA VANGE ( <i>Alternate</i> )
IFCA, Mumbai	SHRI ATINDRA N. CHAUDHURI
Indian Centre for Plastics in the Environment (ICPE), Mumbai	SHRI T.K. BANDOPADHYAY
Indian Institute of Packaging (IIP), Mumbai	DR TANWEER ALAM DR BABU RAO GUDURI ( <i>Alternate</i> )
Indian Institute of Technology (IIT), New Delhi	SHRI ANUP K. GHOSH
Indian Oil Corporation, R&D Centre, Faridabad	DR G. S. KAPOOR SHRI RAJA PODDAR ( <i>Alternate I</i> ) SHRI SUMIT BASU ( <i>Alternate II</i> )
Indian Pharmacopoeia Commission, Ghaziabad	DR JAI PRAKASH DR MANOJ KUMAR PANDEY ( <i>Alternate</i> )
Indian Plastic Institute (IPI), Mumbai	SHRI V. B. LALL SHRI MIHIR BANERJI ( <i>Alternate</i> )
Ministry of Environment & Forests (MoEF), New Delhi	SHRI SATYENDRA KUMAR SHRI AMIT LOVE ( <i>Alternate</i> )
National Committee on Placticulture Applications in Horticulture (NCPAH), Ministry of Agriculture & Farmers Welfare, Govt of India, New Delhi	SHRI ANAND ZAMBRE SHRI KRISHNA KUMAR KAUSHAL ( <i>Alternate</i> )
ONGC Petro Additions Ltd (OPAL), Gujarat	SHRI VIVEK MEHTA
Organization of Plastics Processors of India, Mumbai	DR SATYAPRASAD BHATTACHARYA SHRI DEEPAK LAWALE ( <i>Alternate</i> )
Plastindia Foundation, Mumbai	DR E. SUNDARESAN SHRI HITEN BHEDA ( <i>Alternate</i> )
Reliance Industries Ltd (RIL), Mumbai	SHRI S.V. RAJU SHRI AMIT SHAH ( <i>Alternate</i> )
SABIC Innovative Plastics, Bengaluru	DR SUMANDA BANDYOPADHYAY SHRI SUNIL RAUTO ( <i>Alternate</i> )
Shivalik Agro-Poly Products Ltd, Mohali	SHRI PANKAJ KUMAR MAHAJAN DR G. D. TYAGI ( <i>Alternate</i> )
Technical Training and Research Centre (TTRC), Lohia Group, Kanpur	SHRI R. K. DWIVEDI

<i>Organization</i>	<i>Representative(s)</i>
Voluntary Organization in Interest of Consumer Education (VOICE), New Delhi	SHRI M. A. U. KHAN SHRI H. WADHWA ( <i>Alternate</i> )
BIS Director General	SHRIMATI MEENAL PASSI, SCIENTIST 'F'/SENIOR DIRECTOR AND HEAD (PETROLEUM, COAL AND RELATED PRODUCTS) [REPRESENTING DIRECTOR GENERAL ( <i>Ex-officio</i> )]

*Member Secretary*  
SHRI SHIVAM DWIVEDI  
SCIENTIST 'B'/ASSISITANT DIRECTOR  
(PETROLEUM, COAL AND RELATED PRODUCTS), BIS



## Bureau of Indian Standards

BIS is a statutory institution established under the *Bureau of Indian Standards Act, 2016* to promote harmonious development of the activities of standardization, marking and quality certification of goods and attending to connected matters in the country.

### Copyright

BIS has the copyright of all its publications. No part of these publications may be reproduced in any form without the prior permission in writing of BIS. This does not preclude the free use, in the course of implementing the standard, of necessary details, such as symbols and sizes, type or grade designations. Enquiries relating to copyright be addressed to the Head (Publication & Sales), BIS.

### Review of Indian Standards

Amendments are issued to standards as the need arises on the basis of comments. Standards are also reviewed periodically; a standard along with amendments is reaffirmed when such review indicates that no changes are needed; if the review indicates that changes are needed, it is taken up for revision. Users of Indian Standards should ascertain that they are in possession of the latest amendments or edition by referring to the website- [www.bis.gov.in](http://www.bis.gov.in) or [www.standardsbis.in](http://www.standardsbis.in).

This Indian Standard has been developed from Doc No.: PCD 12 (19402).

### Amendments Issued Since Publication

Amend No.	Date of Issue	Text Affected

## BUREAU OF INDIAN STANDARDS

### Headquarters:

Manak Bhavan, 9 Bahadur Shah Zafar Marg, New Delhi 110002  
Telephones: 2323 0131, 2323 3375, 2323 9402

Website: [www.bis.gov.in](http://www.bis.gov.in)

### Regional Offices:

	Telephones
Central : 601/A, Konnectus Tower -1, 6 <sup>th</sup> Floor, DMRC Building, Bhavbhuti Marg, New Delhi 110002	{ 2323 7617
Eastern : 8 <sup>th</sup> Floor, Plot No 7/7 & 7/8, CP Block, Sector V, Salt Lake, Kolkata, West Bengal 700091	{ 2367 0012 2320 9474
Northern : Plot No. 4-A, Sector 27-B, Madhya Marg, Chandigarh 160019	{ 265 9930
Southern : C.I.T. Campus, IV Cross Road, Taramani, Chennai 600113	{ 2254 1442 2254 1216
Western : Plot No. E-9, Road No.-8, MIDC, Andheri (East), Mumbai 400093	{ 2821 8093

**Branches :** AHMEDABAD. BENGALURU. BHOPAL. BHUBANESHWAR. CHANDIGARH. CHENNAI. COIMBATORE. DEHRADUN. DELHI. FARIDABAD. GHAZIABAD. GUWAHATI. HIMACHAL PRADESH. HUBLI. HYDERABAD. JAIPUR. JAMMU & KASHMIR. JAMSHEDPUR. KOCHI. KOLKATA. LUCKNOW. MADURAI. MUMBAI. NAGPUR. NOIDA. PANIPAT. PATNA. PUNE. RAIPUR. RAJKOT. SURAT. VISAKHAPATNAM.