प्लास्टिक — परीक्षण की पध्दतियाँ

भाग 8 स्थायी/रासायनिक गुणधर्म

अनुभाग 9 पर्यावरणीय प्रतिबल क्रैकिंग (ईएससी) के प्रतिरोध का निर्धारण — बेंट स्ट्रिप विधि

(पहला पुनरीक्षण)

Plastics — Methods of Testing Part 8 Permanence/Chemical Properties Section 9 Determination of Resistance to Environmental Stress Cracking (ESC) — Bent Strip Method (First Revision)

ICS 83.080.01

© BIS 2022



भारतीय मानक ब्यूरो
BUREAU OF INDIAN STANDARDS
मानक भवन, 9 बहादुर शाह ज़फर मार्ग, नई दिल्ली - 110002
MANAK BHAVAN, 9 BAHADUR SHAH ZAFAR MARG
NEW DELHI - 110002

www.bis.gov.in www.standardsbis.in

November 2022

Price Group 7

NATIONAL FOREWORD

This Indian Standard (First Revision) which is identical with ISO 22088-3 : 2006 'Plastics — Determination of resistance to environmental stress cracking (ESC) — Part 3: Bent strip method' issued by the International Organization for Standardization (ISO) was adopted by the Bureau of Indian Standards on the recommendation of the Methods of Sampling and Test for Plastics Sectional Committee and approval of the Petroleum, Coal and Related Products Division Council.

This standard was originally published in 1997 which was identical to ISO 4599 : 1986. ISO 4599 : 1986 has been revised to ISO 22088-3 : 2006. This revision (first) has been undertaken to align it with the latest version of ISO 22088-3 : 2006.

The text of ISO Standard has been approved as suitable for publication as an Indian Standard without deviations. Certain conventions are, however, not identical to those used in Indian Standards. Attention is particularly drawn to the following:

- a) Wherever the words 'International Standard' appear referring to this standard, they should be read as 'Indian Standard'.
- b) Comma (,) has been used as a decimal marker while in Indian Standards, the current practice is to use a point (.) as the decimal marker.

In this adopted standard, reference appears to certain International Standards for which Indian Standards also exist. The corresponding Indian Standards, which are to be substituted in their respective places, are listed below along with their degree of equivalence for the editions indicated:

<i>International Standard</i>	<i>Corresponding Indian Standard</i>	<i>Degree of Equivalence</i>
ISO 178, Plastics — Determination of flexural properties	IS 13360 (Part 5/ Sec 7) : 2017/ISO 178 : 2010 Plastics — Methods of testing: Part 5 Mechanical properties, Section 7 Determination of flexural properties (<i>first revision</i>)	Identical
ISO 179-1, Plastics Determination of Charpy impact properties — Part 1: Non-instrumented impact test	IS 13360 (Part 5/ Sec 5) : 2017/ISO 179-1 : 2010 Plastics — Methods of testing: Part 5 Mechanical properties, Section 5 Determination of Charpy impact properties — Non-instrumented impact test (<i>first revision</i>)	Identical
ISO 527-2, Plastics — Determination of tensile properties — Part 2: Test conditions for moulding and extrusion plastics	IS 13360 (Part 5/ Sec 2) : 2017/ISO 527-2 : 2012 Plastics — Methods of testing: Part 5 Mechanical properties, Section 2 Determination of tensile properties — Test conditions for moulding and extrusion plastics (<i>first revision</i>)	Identical
ISO 2818, Plastics — Preparation of test specimens by machining	IS 13360 (Part 2/ Sec 4) : 2021/ISO 2818 : 2018 Plastics — Methods of testing: Part 2 Sampling and preparation of test specimens, Section 4 Preparation of test specimens by machining (<i>second revision</i>)	Identical

(Continued on third cover)

Contents

Page

1	Scope	1
2	Normative references	1
3	Terms and definitions.....	2
4	Principle.....	4
5	Apparatus	4
6	Test specimens	5
6.1	Form and dimensions.....	5
6.2	Preparation	5
6.3	Number	5
7	Conditioning and test conditions.....	5
7.1	Conditioning.....	5
7.2	Test temperature.....	5
7.3	Test medium.....	5
8	Procedure	5
8.1	Precautions	5
8.2	Mounting the test specimens	5
8.3	Contact with the test environment.....	6
8.4	Storage in contact with the test environment.....	6
8.5	Determination of the indicative property.....	7
9	Expression of results	7
9.1	Calculation.....	7
9.2	Graphical evaluation.....	7
10	Precision.....	8
11	Test report	9
	Bibliography	10

This page has been intentionally left blank

Indian Standard

PLASTICS — METHODS OF TESTING
PART 8 PERMANENCE/CHEMICAL PROPERTIES
Section 9 Determination of resistance to environmental
stress cracking (ESC) — bent strip method
(First Revision)

1 Scope

This part of ISO 22088 specifies a method for the determination of the environmental stress cracking (ESC) resistance of thermoplastics when they are subjected to a fixed flexural strain in the presence of chemical agents.

ESC is indicated by the change of a suitably chosen indicative property of specimens that have been strained for a defined time in the environment. The method of test is suitable for determining the resistance of sheets and of flat test specimens, especially the sensitivity of localized surface regions of specimens, to ESC.

The bent strip method is suitable for the determination of ESC caused by gases and liquids as well as solids containing migrating substances (e.g. polymeric adhesives and materials containing plasticizers) in contact with a specific polymer.

Preferably, this method is used to determine the ESC resistance of rigid plastics that exhibit only moderate stress relaxation during the time of the test.

This is essentially a ranking test and is not intended to provide data to be used for design or performance prediction.

NOTE For a constant-strain test, refer to ISO 22088-5. For a constant-load test, refer to ISO 22088-2.

2 Normative references

The following referenced documents are indispensable for the application of this document. For dated references, only the edition cited applies. For undated references, the latest edition of the referenced document (including any amendments) applies.

ISO 178, *Plastics — Determination of flexural properties*

ISO 179-1, *Plastics — Determination of Charpy impact properties — Part 1: Non-instrumented impact test*

ISO 527-2, *Plastics — Determination of tensile properties — Part 2: Test conditions for moulding and extrusion plastics*

ISO 2818, *Plastics — Preparation of test specimens by machining*

ISO 22088-1:2006, *Plastics — Determination of resistance to environmental stress cracking (ESC) — Part 1: General guidance*

3 Terms and definitions

For the purposes of this document, the following terms and definitions apply.

3.1 flexural strain

ϵ_x
nominal value of the strain in the tensile surface of a flat test specimen of thickness h , bent over the segment of a circle with radius r , calculated from the equation

$$\epsilon_x = \frac{h}{2r + h}$$

NOTE See Figure 1.

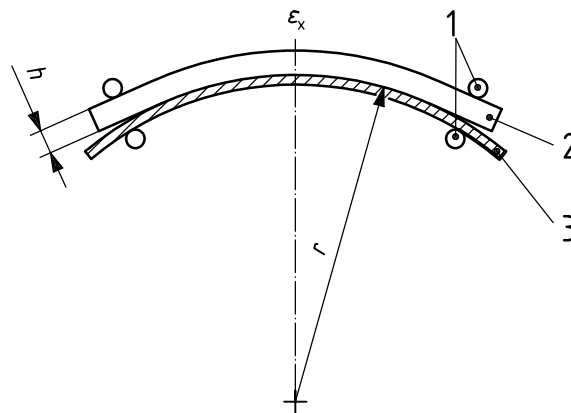

Key

- 1 clamps
- 2 test specimen: tensile surface in contact with test medium
compressive surface in contact with form
- 3 form
- h thickness of test specimen
- r radius of form
- ϵ_x nominal strain in tensile surface

Figure 1 — Test specimen with defined strain in the tensile surface

3.2 strain value

one of a series of strain levels applied to successive test specimens during exposure

3.3 strain series

a number of strain values, including zero

NOTE 1 Normally, the results of the mechanical test on test specimens with zero applied strain are equivalent whether determined in air or in a chemical test medium. If the property measured after exposure to the test medium at zero strain is different from that after exposure in air at zero strain, embrittlement or softening by the test medium should be suspected. In some cases, relief of stresses imparted during specimen preparation such as by injection-moulding or machining can contribute to differences in results for stress cracking in air and another test medium.

NOTE 2 It is recommended that the test specimen for zero strain be clamped on to a flat form to prevent warping due to the effect of the test medium.

**3.4
failure strain**

ϵ_F
lowest strain in the strain series at which failure is observed

**3.5
indicative property**

property observed to determine failure using a criterion such as those given in Table 1

**3.6
ESC index**

ratio of the value of failure strain determined in the test medium to that determined in the reference medium (usually air) for the same time of exposure

Table 1 — Suggested indicative properties and failure criteria (see Note 1)

Indicative property	International Standard	Failure criterion	Designation
State of surface (assessed by visual examination)	—	Cracks or crazes around the tensile surface edges	A1
State of surface (assessed by visual examination)	—	Cracks or crazes in the tensile surface	A2
State of surface (assessed by visual examination)	—	Any other observation, e.g. change in colour or appearance	A3
Tensile stress at break or tensile stress at yield	ISO 527-2	80 % of the value obtained on unstrained unexposed test specimens (see Note 2)	B1
Flexural stress at maximum load	ISO 178	80 % of the value obtained on unstrained unexposed test specimens (see Note 2)	B2
Percentage tensile strain at break or tensile strain at yield	ISO 527-2	50 % of the value obtained on unstrained unexposed test specimens (see Note 2)	B3
Charpy impact strength, unnotched	ISO 179-1	50 % of the value obtained on unstrained unexposed test specimens (see Note 3)	B4
Tensile impact strength	See Note 4	50 % of the value obtained on unstrained unexposed test specimens	B5
Any other property agreed upon	—	To be agreed	B6
<p>NOTE 1 The state of the test specimens, the indicative property and the failure criterion shall be selected with a view to the practical service conditions.</p> <p>NOTE 2 If the material is thought to be anisotropic, two sets of specimens shall be used, one set cut at right angles to the other in two of the principal directions of orientation. This applies only to specimens having the appropriate dimensions.</p> <p>NOTE 3 Data comparisons will only be valid if the failure mode is the same in all cases.</p> <p>NOTE 4 This question is under study.</p>			

4 Principle

A test specimen suitable for the determination of the indicative property is clamped with one of its faces over a form of constant radius and brought into contact with the test environment. Due to the influence of the environment in the presence of strain, crazes may be generated which with time sometimes develop into visible cracks.

By using a series of forms with decreasing radii, a series of test specimens that have increasing strains in the outer surface can be tested.

After an agreed duration of contact with the test environment, the test specimens are visually observed, unclamped and assessed by mechanical or other testing. The failure strain that corresponds to the failure criterion is obtained directly from the tabulated values or graphically.

The maximum strain must be less than the strain at yield.

NOTE 1 The failure criterion is also commonly expressed in terms of the ESC index.

NOTE 2 The failure strains for different indicative properties may be different.

5 Apparatus

5.1 Forms, made from chemical-resistant material either by machining or by bending metal sheet (for example, stainless-steel sheet). For test specimens 2 mm to 4 mm thick, radii of curvature of 30 mm to 500 mm are suitable. The form shall have roughly the same length as the test specimen.

To increase the contact between the test specimen and the test medium, the forms may be perforated.

NOTE The radius r of the segment of a circular arc of height h and chord length l is given by the equation

$$r = \frac{l^2}{8h} + \frac{h}{2}$$

5.2 Clamps, made from chemical-resistant material. The clamps shall be designed so that they hold the test specimen lightly. The contact between the test specimen and the form need not extend to the clamps, but shall extend over that length of test specimen which will be most highly stressed in the subsequent mechanical test. In no case shall the contact region (measured in the direction of the length of the test specimen) be less than 10 times the specimen thickness.

5.3 Vessels, such as carefully cleaned glass containers with well fitting lids, suitable for holding the mounted test specimens and the test medium. Other types of vessel may be used provided there is no interaction between the material of which the vessel is made and the specimens or test medium. When the contact between the test specimens and the test medium takes place under other conditions, such as exposure to a vapour or a water spray, this fact shall be reported.

5.4 Micrometer, capable of determining the thickness of the test specimens to within 0,01 mm.

5.5 Apparatus for determining the indicative property (see 8.5).

6 Test specimens

6.1 Form and dimensions

The shape and dimensions of the test specimens shall be in accordance with the relevant material standard. When no material standard exists, the shape and dimensions shall be in accordance with the test method standard.

If the test specimens are machined from sheets or articles, their thickness shall be the thickness of the sheet or article. This shall be reported, together with the original location of the specimen in the sheet or article.

6.2 Preparation

To obtain comparable results, the test specimens used shall have the same dimensions, state, mode of preparation and age. When cut or machined from sheet or articles, they shall be cut from corresponding places and in corresponding directions. Cut edges shall have a clean finish.

The moulding or machining conditions used for specimen preparation shall be reported.

6.3 Number

Unless otherwise specified, test a minimum of three specimens at each strain level (including zero strain).

7 Conditioning and test conditions

7.1 Conditioning

Unless otherwise agreed between the interested parties (e.g. for polyamides or ABS), the test specimens shall be conditioned for 48 h at (23 ± 2) °C and (50 ± 10) % relative humidity before exposure to the test and reference environments.

7.2 Test temperature

Unless otherwise specified, the indicative property shall be determined at (23 ± 2) °C. If other temperatures are of interest, (40 ± 2) °C or (55 ± 2) °C are preferred but other temperatures may be used by agreement between the interested parties. During storage in the reference environment (normally air), use the same temperature as the test temperature.

7.3 Test medium

See ISO 22088-1:2006, 7.3.

8 Procedure

8.1 Precautions

During all stages of testing, the test specimens shall be protected from contact with anything other than the test environment.

8.2 Mounting the test specimens

Clamp the cleaned test specimens to the forms, starting with zero strain and ending with the form having the smallest radius.

Care shall be taken to handle only the ends of the test specimens. If the test specimens are not clean, clean them before mounting with a liquid that has no effect on them. Cleaning may influence the test results. If specimens are cleaned prior to testing, details of the cleaning procedure shall be included in the test report.

8.3 Contact with the test environment

Immediately after the specimens are mounted, place them in contact with the test environment.

Contact with liquid or gases is established by immersion. Pastes shall be carefully spread to depth of 2 mm to 4 mm over the exposed surfaces of the test specimens. Solids, such as elastomers or plasticized sheet, shall be laid on the surface of the test specimen and sandwiched between this and a second test specimen. This ensures that the contact is established under a definite pressure (see Figure 2).

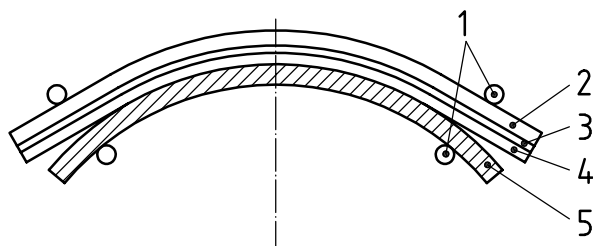

Key

- 1 clamps
- 2 covering test specimen
- 3 PVC sheet containing plasticizer
- 4 test specimen
- 5 form

Figure 2 — Example of a sandwiched test specimen

8.4 Storage in contact with the test environment

8.4.1 Short-time test

Unless otherwise specified, keep the mounted test specimens in the test medium for $24 \text{ h} \pm 15 \text{ min}$.

8.4.2 Long-term test

Keep a series of mounted test specimens in contact with the test medium, removing them for evaluation at regular intervals until any further increase in the length of the contact period is no longer accompanied by a change in the indicative property concerned.

If, at any time during the test, the specimen is not in complete contact with the central area of the form, open the clamps and reclamp the specimen so it is in full contact with the central area of the form. If this is not possible, the test shall be stopped and a new test started.

Testing shall be continued until at least 50 % of the specimens have failed or until some point in time or criterion agreed upon by all interested parties has been reached.

NOTE A preliminary test may be carried out with only one test specimen for each strain value to estimate the failure strain. Equal numbers of strain levels on either side of this failure strain should then be used.

8.5 Determination of the indicative property

Determine the indicative property in accordance with the relevant material specification. If there is no applicable material specification, use the test method relevant to the indicative property but ignore conditioning clauses and use the following procedure.

After the agreed strain time, observe the test specimen visually. When the test medium is a solid, discard it and the covering test specimen (see Figure 2).

Remove each test specimen from its form and determine the indicative property, starting with the test specimen with the lowest strain. Removing excess test medium by wiping with a clean paper tissue or clean cloth is acceptable if agreed upon by the interested parties.

Determine the indicative property as soon as possible after demounting the specimen in the short-time test and within 22 h to 24 h at (23 ± 2) °C in air after demounting in the long-term test.

In flexural and Charpy tests, the surface of the test specimen that was not in contact with the form shall be laid on the supports.

If there is no material standard, use the following tests:

- flexural test (ISO 178): flexural stress at maximum load;
- tensile test (ISO 527-2): tensile strength at break, test speed 50 mm/min.

9 Expression of results

9.1 Calculation

Calculate the arithmetic mean value of the indicative property at each strain level.

9.2 Graphical evaluation

Plot the mean values thus obtained on a graph with the strain as abscissa and the value of the indicative property as ordinate. Draw a smooth curve through the points and interpolate to obtain the failure strain (see Figure 3).

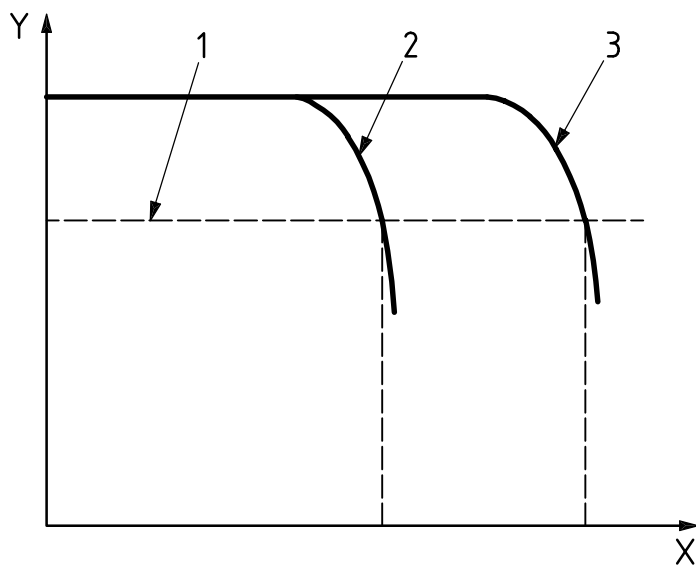

Key

X strain ϵ_x

Y indicative property

1 failure criterion

2 results in test environment

3 results in reference environment

Figure 3 — Graphical evaluation of test results

10 Precision

The precision of these methods is not known because interlaboratory data are not available in view of the variety of plastics materials and environmental conditions. These methods may not be suitable for use in the event of disputed results as long as no precision data are available.

11 Test report

The test report shall include the following particulars:

- a) a reference to this part of ISO 22088;
- b) all details necessary to identify the material tested;
- c) the test medium used;
- d) the test temperature;
- e) the number of specimens tested (if applicable, in each direction of anisotropy) and their width and thickness;
- f) the procedure used for preparation of the specimens and the cleaning procedure, if used;
- g) the state of the specimens;
- h) the conditioning time and temperature;
- i) the indicative property and the method used to determine it;
- j) the failure criterion;
- k) the individual and mean values of the indicative property;
- l) a graphical display of the results;
- m) the failure strain;
- n) the ESC index, if a reference environment was used;
- o) any visual observations (change in colour, crazing, swelling, change in gloss);
- p) any other observations;
- q) details of any deviations from the procedures specified in this part of ISO 22088;
- r) the date of testing.

Bibliography

- [1] ISO 22088-2, *Plastics — Determination of resistance to environmental stress cracking (ESC) — Part 2: Constant tensile load method*
- [2] ISO 22088-5, *Plastics — Determination of resistance to environmental stress cracking (ESC) — Part 5: Constant tensile deformation method*

(Continued from second cover)

The technical committee has reviewed the provisions of the following International Standard referred in this adopted standard and has decided that it is acceptable for use in conjunction with this standard:

<i>International /Other standard no.</i>	<i>Title</i>
ISO 22088-1 : 2006	Plastics — Determination of resistance to environmental stress cracking (ESC) — Part 1: General guidance

In reporting the result of a test or analysis made in accordance with this standard, if the final value, observed or calculated, is to be rounded off, it shall be done in accordance with IS 2 : 2022 'Rules for rounding off numerical values (*second revision*)'.

Bureau of Indian Standards

BIS is a statutory institution established under the *Bureau of Indian Standards Act, 2016* to promote harmonious development of the activities of standardization, marking and quality certification of goods and attending to connected matters in the country.

Copyright

BIS has the copyright of all its publications. No part of these publications may be reproduced in any form without the prior permission in writing of BIS. This does not preclude the free use, in the course of implementing the standard, of necessary details, such as symbols and sizes, type or grade designations. Enquiries relating to copyright be addressed to the Head (Publication & Sales), BIS.

Review of Indian Standards

Amendments are issued to standards as the need arises on the basis of comments. Standards are also reviewed periodically; a standard along with amendments is reaffirmed when such review indicates that no changes are needed; if the review indicates that changes are needed, it is taken up for revision. Users of Indian Standards should ascertain that they are in possession of the latest amendments or edition by referring to the website-www.bis.gov.in or www.standardsbis.in.

This Indian Standard has been developed from Doc No.: PCD 27 (18729).

Amendments Issued Since Publication

Amend No.	Date of Issue	Text Affected

BUREAU OF INDIAN STANDARDS

Headquarters:

Manak Bhavan, 9 Bahadur Shah Zafar Marg, New Delhi 110002
Telephones: 2323 0131, 2323 3375, 2323 9402

Website: www.bis.gov.in

Regional Offices:

	Telephones
Central : 601/A, Konnectus Tower -1, 6 th Floor, DMRC Building, Bhavbhuti Marg, New Delhi 110002	{ 2323 7617
Eastern : 8 th Floor, Plot No 7/7 & 7/8, CP Block, Sector V, Salt Lake, Kolkata, West Bengal 700091	{ 2367 0012 2320 9474
Northern : Plot No. 4-A, Sector 27-B, Madhya Marg, Chandigarh 160019	{ 265 9930
Southern : C.I.T. Campus, IV Cross Road, Taramani, Chennai 600113	{ 2254 1442 2254 1216
Western : Plot No. E-9, Road No.-8, MIDC, Andheri (East), Mumbai 400093	{ 2821 8093

Branches : AHMEDABAD. BENGALURU. BHOPAL. BHUBANESHWAR. CHANDIGARH. CHENNAI. COIMBATORE. DEHRADUN. DELHI. FARIDABAD. GHAZIABAD. GUWAHATI. HIMACHAL PRADESH. HUBLI. HYDERABAD. JAIPUR. JAMMU & KASHMIR. JAMSHEDPUR. KOCHI. KOLKATA. LUCKNOW. MADURAI. MUMBAI. NAGPUR. NOIDA. PANIPAT. PATNA. PUNE. RAIPUR. RAJKOT. SURAT. VISAKHAPATNAM.