56 मिमी और उससे अधिक ऊँचाई की
शाफ़्ट के साथ घूर्णी विद्युत मशीनों का
यांत्रिक कम्पन — कम्पन तीव्रता का मापन,
मूल्यांकन और सीमा
(IEC 60034-14 : 2018, संशोधित)
(दूसरा पुनरीक्षण)

**Mechanical Vibration of Rotating
Electrical Machines with Shaft
Heights 56 mm and Higher —
Measurement, Evaluation and Limits
of Vibration Severity**
(IEC 60034-14 : 2018, MOD)
(Second Revision)

ICS 29.160.01

© BIS 2024



भारतीय मानक ब्यूरो
BUREAU OF INDIAN STANDARDS
मानक भवन, 9 बहादुर शाह ज़फर मार्ग, नई दिल्ली - 110002
MANAK BHAVAN, 9 BAHADUR SHAH ZAFAR MARG
NEW DELHI - 110002
www.bis.gov.in www.standardsbis.in

FOREWORD

This Indian Standard (Second Revision) was adopted by the Bureau of Indian Standards, after the draft finalized by the Rotating Machinery Sectional Committee had been approved by the Electrotechnical Division Council.

This standard was first published in 1987 and subsequently revised in 2008 to remove difficulties faced during the implementation of this standard and also to take into account the latest developments in the field of electro-technology. This revision has been brought out in line with international practices with the following significant technical changes with respect to previous version:

- a) Exclusion of turbine generators greater than 20 MW and machines with magnetic bearings;
- b) Clause [4.2](#), [4.3](#), [5](#), [6.2.3](#), [6.2.4](#), [6.3](#) are upgraded in line with IEC 60034-14 : 2018;
- c) Clause [7.2](#), [7.3](#), [8.1](#), [8.3](#), [8.4](#) and [9](#) are upgraded in line with IEC 60034-14 : 2018;
- d) Limits of vibration magnitude defined under rigid mounting condition for frame size more than 132;
- e) New vibration Grades A & B are defined;
- f) Reduction of Limits of vibration magnitude for two pole motors in frame sizes above 225 to make it in line with IEC 60034-14 : 2018;
- g) Split of Table 2 into [Table 2A](#) and [Table 2B](#);
- h) Replacement of ‘vibration severity’ with term ‘vibration magnitude’; and
- j) Reference standards have been updated with latest version.

While formulating this standard, assistance has been derived from IEC 60034-14 : 2018 ‘Rotating electrical machines — Part 14: Mechanical vibration of certain machines with shaft heights 56 mm and higher—measurement, evaluation and limits of vibration severity’.

The composition of the Committee responsible for the formulation of this standard is given in [Annex A](#).

For the purpose of deciding whether a particular requirement of this standard is complied with, the final value, observed or calculated, expressing the result of a test, shall be rounded off in accordance with IS 2 : 2022 ‘Rules for rounding off numerical values (*second revision*)’. The number of significant places retained in the rounded off value should be the same as that of the specified value in this standard.

Indian Standards

**MECHANICAL VIBRATION OF ROTATING ELECTRICAL
MACHINES WITH SHAFT HEIGHTS 56 mm AND HIGHER —
MEASUREMENT, EVALUATION AND LIMITS
OF VIBRATION SEVERITY
(IEC 60034-14 : 2018, MOD)
(Second Revision)**

1 SCOPE

1.1 This standard specifies the factory acceptance vibration test procedure, measurement conditions and fixes the limits for the level of vibration magnitude of an electrical machine under specified conditions when the machine is uncoupled from any load or prime mover, at a testing department, under properly controlled conditions.

1.2 This standard is applicable to dc machines and three-phase a.c. machines with shaft center height 56 mm and higher and a rated power output up to 50 MW, at nominal speeds from 500 rpm up to and including 3 000 rpm.

NOTE — The mechanical vibrations in rotating machines of speed lower than 500 rpm shall be subject to agreement between the purchaser and the manufacturer.

1.3 For vertical and flange mounted machines vibrations are to be measured in a state of free suspension. However, for vertical machines having shaft height greater than 400 mm the vibration may also be measured with rigid mounting. Under this condition the vibration limits as applicable to horizontal machines will be applicable (*see* [8.2](#)).

1.4 This standard is not applicable to machines mounted *in-situ* (*on site*), three-phase commutator motors, single phase machines, three-phase machines operated on single-phase systems, vertical water power generators, turbine generators greater than 20 MW, machines with magnetic bearings, permanent magnet generators or series wound d.c. machines and motors for submersible pumps.

NOTE — The shaft height of a machine without feet, or a machine with raised feet, or any vertical machines, is to be taken as the shaft height of a machines in the same basic frame, but of the horizontal shaft mounted type IMB3 (*see* IS 2253), designation for types of construction and mounting arrangement of rotating electrical machines).

1.5 Vibration in rotating electrical machines are caused by:

- a) Unbalance in the rotating masses;
- b) Slight deformations in the frame or bed of the machine caused by certain magnetic attraction between the stator and rotor;

- c) Rolling bearing; and
- d) Aerodynamic loads and some secondary effects such as instability of the shaft in the bearings, passive resistance, asymmetric expansion, etc.

In spite of accurate balancing that can be achieved, residual unbalance generally proves to be the main cause of once per revolution vibrations found in the machine.

The measurement of vibrations is closely linked with the mounting of the machine and it is generally desirable to carry out vibration measurements under actual installation and operating conditions. However, to estimate the quality of balance as far as balance and vibrations of rotating electrical machines are concerned, it is necessary to measure the vibrations on the machine alone under proper test conditions which permit reproducible tests to be carried out and provide comparable measurements.

2 REFERENCES

The standards given below contain provisions which, through reference in this text, constitute provision of this standard. At the time of publication, the editions indicated were valid. All standards are subject to revision, and parties to agreements based on this standard are encouraged to investigate the possibility of applying the most recent edition of these standards:

<i>IS No.</i>	<i>Title</i>
IS 2253 : 1974	Designation for types of construction and mounting arrangement of rotating electrical machines (<i>first revision</i>)
IS 11726 : 2017/ ISO 2954 : 2012	Mechanical vibration of rotating and reciprocating machinery — Requirements for instruments for measuring vibration severity (<i>first revision</i>)
IS 15999 (Part 1) : 2021	Rotating electrical machines specification (<i>second revision</i>)

To access Indian Standards click on the link below:

https://www.services.bis.gov.in/php/BIS_2.0/bisconnect/knowyourstandards/Indian_standards/isdetails/

3 TERMS AND DEFINITIONS

For the purpose of this standard, the terms and definitions given in IS 15999 (Part 1) apply.

3.1 Vibration Magnitude — Vibration magnitude is defined as a comprehensive and simple characteristic unit for describing the vibratory state of a machine, is used as the basis of classification and on the basis of theoretical considerations and practical experience. The root-mean square value of vibration velocity has been chosen as the unit of measurement for indicating vibration magnitude.

3.1.1 In critical cases and under special conditions, evaluation of the behavior of a machine based on vibration magnitude should not be used in lieu of more precisely measured significant parameters, for example, stresses measured at bearings and joints. In general, the use of vibration magnitude as a criterion provides a relatively reliable evaluation requiring only simple measurements.

NOTE — ‘Vibration magnitude’ is a generic term which designate a value, such as maximum average or other significant numerical value descriptive of a vibration. The vibration magnitude of machine is defined as the maximum of root-mean square value of a vibration velocity measured at significant points of a machine, such as bearings, mounting point, etc.

4 MEASUREMENT QUANTITIES

4.1 General

Measurement quantities are the vibration velocity at the machine bearings and the relative shaft vibration displacement within or near to the machine bearings.

4.2 Vibration Magnitude

The criterion for the vibration magnitude at the machine bearings shall be the broadband rms value of the vibration displacement in micrometers or the vibration velocity in millimetres per second in the frequency range specified in 5. The maximum value, determined at the prescribed measurement positions and prescribed measuring variable, according to this standard, characterizes the vibration magnitude of the machine.

Induction motors (especially of two pole type) frequently show vibration beating at twice slip frequency. In these cases, the decisive vibration magnitude shall be determined from the relationship:

$$X_{\text{rms}} = \frac{X_{\text{max}}^2 + X_{\text{min}}^2}{\sqrt{2}}$$

where

X_{max} is the maximum r.m.s. value of vibration displacement or vibration velocity; and

X_{min} is the minimum r.m.s. value of vibration displacement or vibration velocity.

The sample rate shall be chosen large enough to reliably capture the maximum and minimum values of the vibration.

NOTE — Large a.c. induction machines running at very low slip values at no load may require several minutes to more than ten minutes for such measurements to be completed at each vibration measuring position.

4.3 Relative Shaft Vibration (This is same as IEC 60034-14 : 2018)

The criterion adopted for the relative shaft vibration shall be the vibratory displacement S_{p-p} in the direction of measurement from ISO 20816-1.

5 MEASUREMENT EQUIPMENT

The measurement equipment shall be capable of measuring broadband r.m.s. vibration with flat response over a frequency range of 10 Hz to 1 000 Hz, in accordance with the requirements of ISO 2954. However, for machines with speeds approaching or below 600 per minute, the lower limit of the flat response frequency range shall not be greater than 2 Hz. Measurement equipment for relative shaft vibration measurements shall comply with the requirements in ISO 10817-1.

Multi-directional vibration sensors shall not be used.

NOTE — Multi-directional sensors do not provide proper vibration measurement in all directions when mounted in only one location.

6 MACHINE MOUNTING

6.1 General

The vibration of an electrical machine is closely linked with the mounting of the machine. To permit evaluation as far as balance and vibration of rotating electrical machines are concerned, it is necessary to measure the vibration on the machine alone, under properly determined test conditions, to enable reproducible tests to be carried out and to provide comparable measurements.

6.2 Free Suspension

6.2.1 The condition of free suspension may be achieved by following methods:

- a) Free suspension by resilient means, such as hemp, wire rope, V belt or spring; and

- b) Freely supported on an elastic material (rubber sheets, rubber dampers) or spring.

6.2.2 The highest natural oscillation frequency (f_{no}) of the suspension system and machine, shall be less than 1/3 of the frequency f_1 corresponding to the speed of the machine under test, as defined in [7.3](#).

6.2.3 Based on the mass of the machine being tested, the necessary elasticity of the suspension system as a function of rated speed from 600 per min to 3 600 per min can be determined from [Fig. 1](#). For speeds lower than 600 per min measurement in free suspension are not practical. For speeds greater than 3 600 per min, the static displacement Z should be not less than the value for 3 600 per min..

NOTE — To reduce the influence of the mass and the moment of inertia of the suspension system on the vibration level, the effective mass of the elastic support should not be greater than 1/10 of that of the machine.

6.2.4 The curve in [Fig. 1](#) presents the minimum elastic displacement to attain the necessary vertical rigid body natural oscillation, which is usually the highest rigid body natural frequency.

Static displacement Z is expressed as:

$$Z = \frac{a^2 g}{(2\pi n)^2}$$

$$a = \frac{f_1}{f_{no}} ; a \geq 3$$

where

Z is the displacement in m;

n is the rated speed in units of per second; and
 g is the acceleration of gravity (9.81 m/s²).

When a is set to 3, then the curve in [Fig. 1](#) is generated.

6.3 Rigid Mounting

6.3.1 Foundation

6.3.1.1 General

During the shop running test of the assembled machine, vibration measurements shall be made with the machine properly shimmed and securely fastened to a massive foundation or test floor stand. Elastic mounts are not permitted.

The horizontal and vertical natural frequencies of the complete test arrangement shall not coincide within:

- a) ± 10 percent of the rotational frequency of the machine;
- b) ± 5 percent of twice the rotational frequency; and
- c) ± 5 percent of once and twice the electrical line frequency.

Either one of the following two mounting conditions may be chosen by the manufacturer.

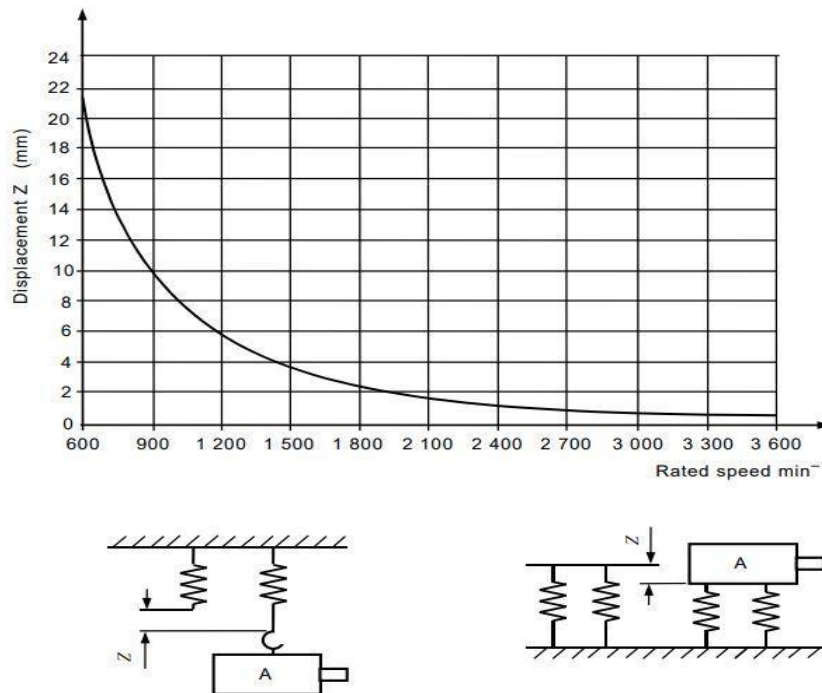

FIG. 1 MINIMUM ELASTIC DISPLACEMENT AS A FUNCTION OF RATED SPEED

6.3.1.2 Rigid mounting on massive foundation

One indication of massive foundation is when the vibration velocity measured in the horizontal and vertical directions at the machine feet (or at the base frame near to the bearing pedestals or stator feet) does not exceed 30 percent of the maximum velocity, which is measured at the adjacent bearing housing in the same measurement direction. The ratio of foot to bearing vibration velocities is valid for the rotational frequency component or twice-line frequency component (if the latter is being evaluated).

NOTES

1 The rigidity of a foundation is a relative quantity. It is compared with the rigidity of the machine bearing system. The ratio of bearing housing vibration to foundation vibration is a characteristic quantity for the evaluation of foundation flexibility.

2 If the machine is to be supported in the field by a structure other than a massive foundation, it may be necessary to perform a system dynamic analysis to make the necessary changes to the foundation dynamic stiffness.

6.3.1.3 Rigid mounting on test floor stand

This condition is achieved by mounting the machine on an adequately rigid test foundation free of resonances at forcing frequencies, (see [6.3.1.1](#)).

NOTE — This mounting is the most used in manufacturers test labs.

6.3.2 Horizontal Machines

The machine under test shall be bolted or clamped using all bolt-hole positions to a foundation that meets the requirements of [6.3.1.2](#) or [6.3.1.3](#).

There are constructions and mountings in which the above fixing conditions cannot be met, such as single-bearing machines. In those cases, there should be an agreement between the supplier and customer.

6.3.3 Vertical Machines

Vertical machines shall be mounted onto a solid rectangular or circular steel plate with a bore hole in the centre of the shaft extension, a machined surface for the flange of electrical machine being measured and holes provided for fasteners or clamps. The steel plate thickness shall be at least three times greater than the machine flange thickness; five times is recommended. The edge length respective to the diameter shall be at least equal to the height of the top bearing, *L*. [Fig. 6](#) is an example for IM V1 (see IEC 60034-7).

Example

For frame 450 (F 940 B), the thickness of flange

is 25 mm, thus the plate thickness to be 125 mm or higher which is difficult to maintain in industries. Higher frames will require much higher thicknesses. Current practice in Indian industries is to use lesser thickness and no adverse reposes observed.

The steel base shall be clamped firmly and tilt safe to a solid floor and meet the requirements to [6.3.1.2](#) or [6.3.1.3](#). The flange connection shall use the correct number of fasteners or clamps. If the above method of mounting is not reasonable, other arrangements can be per agreement between supplier and customer.

6.4 Active Environment Determination

The support systems described in [6.2](#) and [6.3](#) are considered passive, admitting insignificant external disturbances to the machine. When, for the same measurement position, the vibration magnitude with the machine at standstill exceeds 25 percent of the value when the machine is running, then an active environment is said to exist and this standard does not apply (see ISO 20816-1).

7 CONDITIONS OF MEASUREMENT

7.1 Key

Unless otherwise specified and agreed upon, the measurement of vibration shall be carried out with half key in its shaft extension keyway.

NOTE — A full length rectangular key of half height or a half-length key of full height (which should be centered axially in the keyway) is acceptable as practical alternatives.

7.2 Measurement Positions and Directions

7.2.1 Measurement Positions for Vibration

The location of the preferred measurement positions and directions to which the levels of vibration magnitude apply are shown in [Fig. 2](#) for machines with end-shield bearings and in [Fig. 4](#) for machines with pedestal bearings. [Fig. 3](#) applies to those machines where measurement positions according to [Fig. 2](#) are not possible without disassembly of parts.

When measurements cannot be performed per [Fig. 2](#) or [Fig. 3](#), there should be an agreement between supplier and customer. [Fig. 6](#) applies to machines mounted in the vertical position.

NOTES

1 Unless otherwise stated, the measured vibration values are taken normal to the machine surface.

2 Measurement according to [Fig. 3](#) might be on the frame as close to the bearing housing as possible.

3 Axial vibration measurement may not be possible without disassembly on both ends. If a machine has thrust bearings, this may be per agreement between supplier and customer, (see 8.3).

7.2.2 Measurement Positions for Relative Shaft Displacement

Non-contacting transducers shall be installed inside the bearing, measuring directly the relative shaft journal displacement, or (when inside mounting is not possible) adjacent to the bearing shell. The preferred radial positions are as indicated in [Fig. 5](#).

7.3 Test Conditions

7.3.1 Machines shall be tested at no-load and uncoupled operation with all relevant quantities at their rated value. Fixed speed a.c. machines shall be run with a sinusoidal supply voltage according to IS 15999 (Part 1).

7.3.2 The test shall be performed at each rated fixed speed or over the rated speed range for variable frequency drives. For all tested speeds, the values shall not exceed the corresponding limit in [Table 1](#).

This test may be carried out using a converter supply (the actual converter to be installed with the motor on site) or with sinusoidal ac supply as agreed between the manufacturer and the purchaser.

NOTE — Tests with variable-frequency power supply normally only confirm mechanically induced vibrations. It is possible that electrically induced vibrations will be different. If possible, the tests with the actual converter to be installed with the motor on site will provide better information about vibration behavior.

7.3.3 d.c. machines shall be excited with nominal current and shall be fed with such voltage so as to run at nominal speed. In order to discern the mechanically induced vibration from other vibration excitation forces, it is recommended that d.c. machines are tested with a low current ripple supply or pure d.c.

7.3.4 For routine testing of variable-speed machines, it is permitted to test at a single speed based upon information obtained during type test.

7.3.5 For machines that are bi-directional, the vibration limits apply for both directions of rotation, but need to be measured in only one direction.

7.4 Vibration Transducer

The mounting of the transducer used for vibration measurement on the machine surface shall be as specified by the manufacturer of the transducer and shall not disturb the vibratory condition of the machine under test.

For this, it is necessary that the total coupled mass of the transducer assembly is less than 1/50 of the mass of the machine.

8 LIMITS OF BEARING HOUSING VIBRATION

8.1 Limits of Vibration Magnitude in Velocity Mode

The limits apply to the measured broadband r.m.s. vibration velocity and displacement in the frequency range specified in [5](#).

The vibration magnitude for d.c. and three phase a.c. machines with shaft heights 56 mm and higher, for one of either of the two mounting conditions according to [6](#), shall not exceed the limits specified in [Table 1](#). Limits are given for two vibration grades. When no grade is specified, machines complying with this standard shall be Grade A.

For routine tests of standard machines with rotational speeds less than 600 per min, vibration is to be expressed in units of displacement. For rotational speeds from 600 per min up to 15 000 per min, vibration is to be expressed in units of velocity.

When the routine test is made with a free-suspension mounting condition, the type test should also include testing with rigid mounting. This is valid for the whole speed range of this standard.

NOTES

1 Provided that no other agreements are made, the recommended limits of Grade 'A' apply to normal electrical machines. Grade 'B' machines are generally used for machine tool drives.

2 The manufacturer and the purchaser take into account that the instrumentation can have a measurement tolerance of ± 10 percent wrt true value.

3 In case of dispute, arising out of the two methods used, the values in [Table 1](#) shall prevail for deciding conformity to this standard.

4 A machine which is well-balanced in itself and of a grade conforming with [Table 1](#) may exhibit large vibrations when installed on site arising from various causes, such as balance of apparatus to which the machine is coupled, unsuitable foundations, stiffness of the foundation or supporting structure, reaction of the driven machine, current ripple from the power supply, etc. Vibration may also be caused by driving elements with a natural oscillation frequency very close to the excitation due to the small residual unbalance of the rotating masses of the machine.

5 Because of these factors higher vibration limits are permissible on site, but the values should not exceed 125 percent of the value specified in [Table 1](#) and [Table 2](#). The responsibility of ensuring the above lies with the user/site personnel.

6 In such cases, checks should be carried out on site not only on the machine, but also on each element of the installation. (see ISO 10816-3)

7 As mentioned for onsite operation in ISO 20816-1, special agreements can be made. The values given in ISO 20816-1 are the basis for the ease of discussion and agreement between the supplier and the user. The values ensure in most applications that major errors or unrealistic requirements are avoided. Special agreements are also made for acceleration and deceleration ramps. Short term vibration limits and reduced bearing life time as a function of vibration velocity can be given by the manufacturer.

8 The shaft height of a machine without feet, or a machine with raised feet, or any vertical machine is to be taken as the shaft height of a machine in the same basic frame, but of the horizontal shaft foot-mounted type.

8.2 Limits of Vibration Magnitude in Displacement Amplitude Mode

The measurement of vibration magnitude in displacement amplitude mode may be carried out when the facility for measurement in velocity mode is not available in the instrument. The limits of vibration in displacement amplitude mode as given in [Table 2A](#) and [Table 2B](#) are derived values

using the following formula:

$$A = 0.45 V_{rms}/f$$

where

- A = double amplitude of vibration displacement, mm;
- V_{rms} = rms value of velocity of vibration, in mm/s; and
- F = frequency of vibration.

This is based on the assumption of sinusoidal simple harmonic motion corresponding to rotor speed that is

$$f = \text{rpm}/60$$

NOTE — The conversion from velocity to displacement can be accomplished for single frequency harmonic component using this formula.

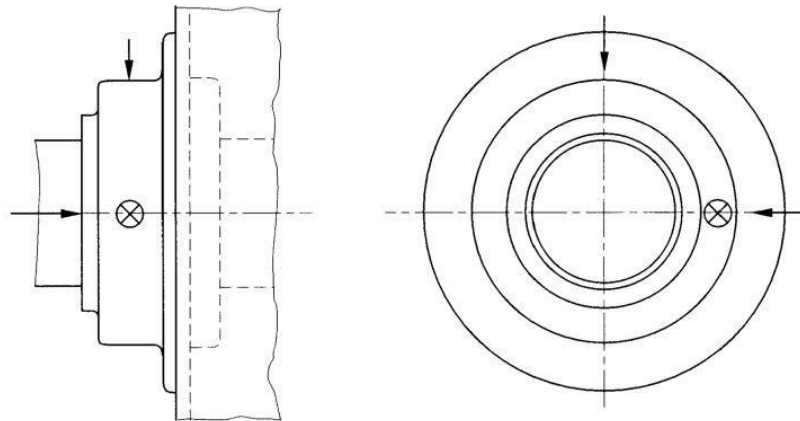

FIG. 2 PREFERRED POSITIONS OF MEASUREMENT APPLICABLE TO ONE OR BOTH ENDS OF THE MACHINE

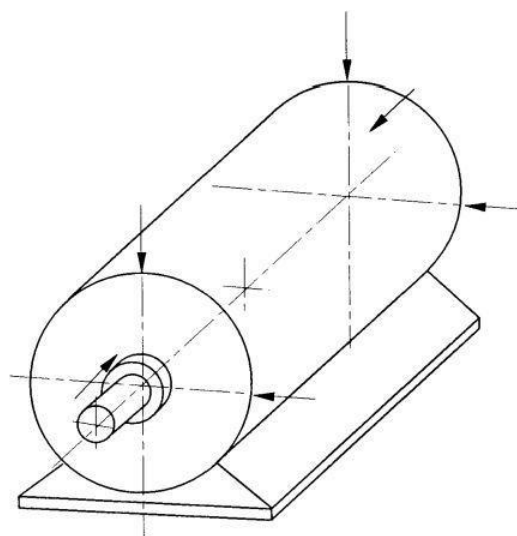

FIG. 3 MEASUREMENT POSITIONS FOR THOSE ENDS OF MACHINES WHERE MEASUREMENTS ACCORDING TO [FIG. 2](#) ARE NOT POSSIBLE WITHOUT DISASSEMBLY OF PARTS

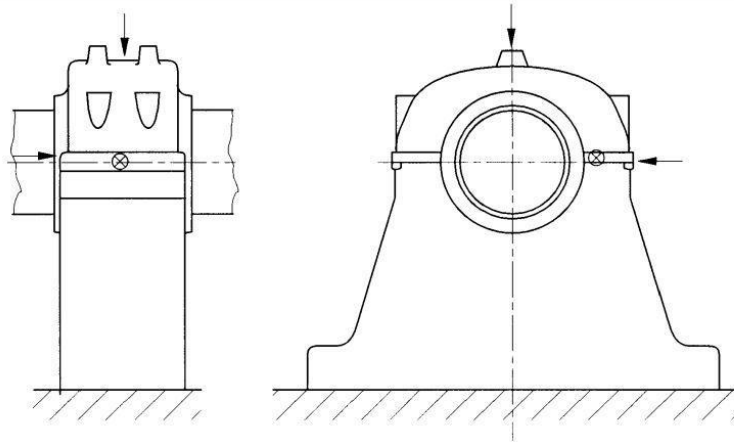
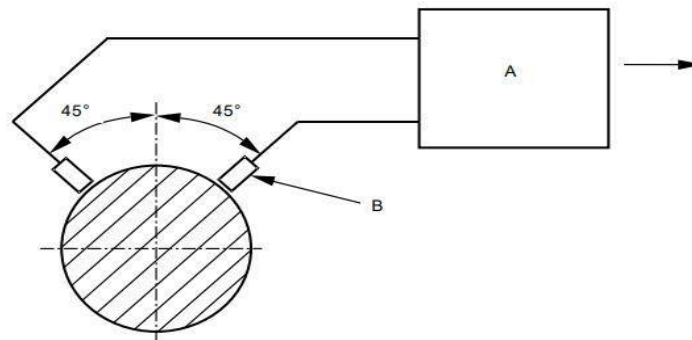

FIG. 4 MEASUREMENT POSITIONS FOR PEDESTAL BEARING



Key
 A signal conditioner
 B transducer

FIG. 5 PREFERRED CIRCUMFERENTIAL POSITION OF TRANSDUCERS FOR THE MEASUREMENT OF RELATIVE SHAFT DISPLACEMENT

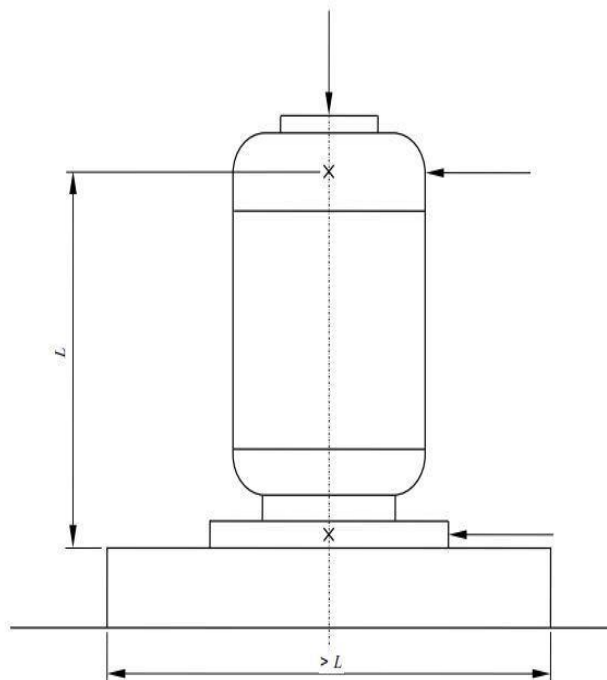

FIG. 6 MEASUREMENT POSITIONS FOR VERTICAL MACHINES (MEASUREMENTS TO BE MADE AT THE BEARING HOUSING; WHEN NOT ACCESSIBLE, THEN AS CLOSE AS POSSIBLE)

Table 1 Limits of Maximum Vibration Magnitude in Velocity Mode for Shaft Height (H)

(Clauses 7.3.2, 8.1, 8.3 and 8.4)

Sl No.	Vibration Grade	Shaft Height mm	56 < H ≤ 132	132 < H ≤ 225	225 < H ≤ 400	H > 400				
(1)	(2)	(3)	(4)	(5)	(6)	(7)				
i)		Range of speed, rpm	500 to 1 500	> 1 500 and upto 3 000	500 to 1 500	> 1 500 and upto 3 000	500 to 1 500	> 1 500 and upto 3 000		
rms values of vibration velocity in mm/s for the shaft height H, in mm										
ii)	A	Free Suspension	1.8	1.8	1.8	2.8	2.8	3.2	2.8	3.2
iii)	A	Rigid Mounting	—	—	1.5	2.3	2.8*	2.3	2.8	3.2*
iv)	B	Free Suspension	0.71	0.71	0.71	1.12	1.8	2.3	1.8	2.3
v)	B	Rigid Mounting	—	—	0.6	0.9	1.1*	1.5	1.8	1.8*

NOTES

- 1 Grade A applies to machines with no special vibration requirements.
- 2 Grade B applies to machines with special vibration requirements.
- 3 Rigid mounting is not considered acceptable for machines with shaft heights less than or equal to 132 mm.
- 4 Vibration at frequencies above 1 000 Hz should be filtered out.
- 5 The shaft height of a machine without feet, or a machine with raised feet, or any vertical machine is to be taken as the shaft height of a machine in the same basic frame, but of the horizontal shaft foot mounting type.

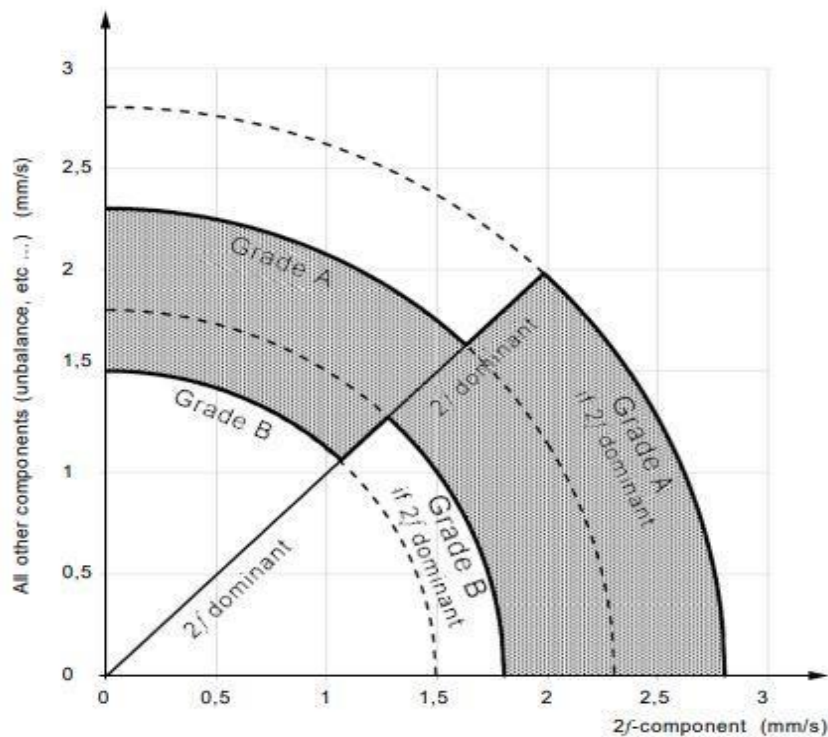

FIG. 7 VIBRATION LIMIT DIAGRAM FOR SHAFT HEIGHTS H > 132 mm

* This level is the limit when the twice line frequency vibration level is dominant as defined in 8.2 and explained in Fig. 7.

Table 2A Derived Values of Limits of Vibration Severity in Rotating Electrical Machines Measured in State of Free Suspension (Displacement Mode)

(Foreword, Clauses 8.1, 8.2, and 8.4)

Sl No.	Shaft Height μm	$56 < H \leq 132$						$132 < H \leq 225$					
		(3)						(4)					
i)	Speed,	500	600	750	1 000	1 500	3 000	500	600	750	1 000	1 500	3 000
ii)	rpm	Vibration limit in maximum displacement amplitude, in μm											
iii)	A	96	80	64	48	32	16	96	80	64	48	32	25
iv)	B	36	30	24	18	12	6	36	30	24	18	12	10

NOTE — For the purpose of Table 2, 'f' is assumed as frequency corresponding to rotor rpm. But for evaluation the dominant frequency should be determined by spectrum analysis and only that frequency should be used for calculation.

Table 2B Derived Values of Limits of Vibration Severity in Rotating Electrical Machines Measured in State of Free Suspension (Displacement Mode)

(Clauses 8.1, 8.2 and 8.4)

Sl No.	Shaft Height	$225 < H \leq 400$						$H > 400$					
		(3)						(4)					
i)	Speed (rpm)	500	600	750	1 000	1 500	3 000	500	600	750	1 000	1 500	3 000
ii)		Vibration limit in maximum displacement amplitude, in μm											
iii)	A	150	125	100	75	50	25	150	125	100	75	50	25
iv)	B	96	80	64	48	32	16	96	80	64	48	32	16

NOTE — For the purpose of Table 2, 'f' is assumed as frequency corresponding to rotor rpm. But for evaluation the dominant frequency should be determined by spectrum analysis and only that frequency should be used for calculation.

8.3 Limits of Vibration Velocity with Twice-Line Frequency for a.c. Machines

Two-pole induction machines may have electromagnetic excited vibration at twice the frequency of the power system. The correct evaluation of these vibration components requires a rigid mounting of the machine, which complies with the requirements given in 6.3.

When type tests demonstrate a dominant twice line frequency component for machines having $H > 132$ mm, the vibration magnitude limit in Table 1 (for Grade A) is increased to 3.2 mm/s (r.m.s.) from 2.8 mm/s (r.m.s.) or (for Grade B) is increased to 1.8 mm/s (r.m.s.) from 1.5 mm/s (r.m.s.). Greater values are subject to prior agreement. A twice line frequency component is considered dominant when type tests demonstrate it to be greater than 70 % of 2.3 mm/s (r.m.s.) (for Grade A) or 70 % of 1.5 mm/s (r.m.s.)

(for Grade B). Graphical interpretation of the definition above is shown in Fig. 7.

When type tests demonstrate a dominant twice line frequency component for machines having $H > 132$ mm, the revised values are shown in the Table 1. A twice line frequency component is considered dominant when type tests demonstrate it to be greater than 70 percent of r.m.s. values for Grade A/Grade B. Graphical interpretation of the definition above is shown in Fig. 7.

NOTES

1 With respect to the twice-line frequency component agreements between the supplier and the customer can be made.

2 70 percent approximates $(1/\sqrt{2}) \times 100$ percent, where the rms values of rotational and twice-line frequency are equal.

8.4 Axial Vibration

The evaluation of axial bearing vibration depends on the bearing function and bearing construction.

In the case of thrust bearings, axial vibration correlates with thrust pulsations, which could cause damage to the metal liner of sleeve bearings or to parts of antifriction bearings. Axial vibration of these bearings shall be evaluated in the same manner as transverse vibration and limits of [Table 1](#) and [Table 2](#) shall apply.

For bearings having no axial limiting construction such as sleeve bearings with no axial thrust bearing, the requirement may be relaxed by prior agreement.

9 LIMITS OF RELATIVE SHAFT VIBRATION

Relative shaft vibration measurements are recommended only for sleeve bearing machines with speeds $> 1\,200\text{ min}^{-1}$; rated power $> 1\,000\text{ kW}$;

and shall be subject to prior agreement between manufacturer and purchaser with respect to the necessary provisions regarding the installation of shaft measurement transducers.

When machines with sleeve bearings have special provisions for the installation of shaft vibration measurement transducers, the limits for the relative shaft vibration displacement are specified in [Table 3](#). These limits are in addition to those required in [8](#).

10 BIS CERTIFICATION MARKING

The product(s) conforming to the requirements of this standard may be certified as per the conformity assessment schemes under the provisions of the *Bureau of Indian Standards Act, 2016* and the Rules and Regulations framed there under, and the products may be marked with the Standard Mark.

Table 3 Limits for the Maximum Shaft Vibration (Sp-p) and the Maximum Run-Out
([Clause 9](#))

SI No.	Vibration Grade	Speed Range 1/Min	Maximum Relative Shaft Displacement μm	Maximum Combined Mechanical and Electrical Runout μm
(1)	(2)	(3)	(4)	(5)
i)	A	$> 1\,800$	65	16
		$\leq 1\,800$	90	23
ii)	B	$> 1\,800$	50	12.5
		$\leq 1\,800$	65	16

NOTES

1 Machines with vibration Grade B are frequently specified for high-speed drives in critical installations.

2 All limits apply to both 50 Hz and 60 Hz machines.

3 The maximum relative shaft displacement limits include the run-out.
For the definition of the run-out (*see* ISO/DIS 7919-1).

ANNEX A

(Foreword)

COMMITTEE COMPOSITION

Rotating Machinery Sectional Committee, ETD 15

<i>Organization</i>	<i>Representative(s)</i>
Bharat Heavy Electricals Limited, Bhopal	SHRI MUKESH KUMAR MARAVI (Chairperson)
Asea Brown Boveri Limited, Faridabad	SHRI LOKESH B. M. SHRI SUMIT TYAGI (<i>Alternate</i>)
Bharat Bijlee Limited, Mumbai	SHRI SALIL KUMAR MS BHAGYASHREE SANJAY PAWAR (<i>Alternate</i>)
Bharat Heavy Electrical Limited, New Delhi	SHRI KRUSHNA CHANDRA PANDA SHRI P. DALI NAIDU (<i>Alternate</i>)
Central Electricity Authority, New Delhi	SHRI JITESH SHRIVAS SHRI RISHABH GAUR (<i>Alternate</i>)
Central Power Research Institute, Bengaluru	SHRI S. PRASHOB
Electrical Research and Development Association, Vadodara	SHRI RAVI SINGH SHRI JITENDRA TAHILWANI (<i>Alternate</i>)
Engineers India Limited, New Delhi	SHRI RAMAN SOOD SHRI S. SRIHARI (<i>Alternate I</i>) SHRI RAVISH K. RAMAN (<i>Alternate II</i>)
Havells India Limited, Noida	SHRI VINAYAK ATRE SHRI ANIL SUKUMAR AKOLE (<i>Alternate</i>)
Hindustan Electric Motors, Mumbai	SHRI SANJAY P. JADIA SHRI DILIP BHAVE (<i>Alternate</i>)
Indian Electrical and Electronics Manufacturers Association, New Delhi	SHRI SEETHARAMAN K. SHRI PRAVEEN KUMAR (<i>Alternate</i>)
Indian Pump Manufacturers Association, Mumbai	SHRI K.V. KARTHIK SHRI UTKARSH. A. CHHAYA (<i>Alternate I</i>) SHRI ANOOP AGARWAL (<i>Alternate II</i>)
Ingersoll Rand India Limited, Ahmedabad	SHRI KAUSHAL PANDYA SHRI HARSH SHUKLA (<i>Alternate</i>)
Integrated Electric Company Private Limited, Bengaluru	SHRI PRAVEEN VIJAYRAGHAVAN DR PRAVEEN VIJAYRAGHAVAN (<i>Alternate</i>)
International Copper Association India, Mumbai	SHRI K. N. HEMANTH KUMAR SHRI JYOTISH PANDE (<i>Alternate I</i>) SHRI SANJAY NAMDEO (<i>Alternate II</i>)
NTPC Limited, New Delhi	SHRI B. V. V.S GANESH SHRI S. N. TRIPATHI (<i>Alternate</i>)
Nuclear Power Corporation of India Limited, Mumbai	SHRI RITESH M. CHOVIATIA SHRI JAYANTH KUMAR BOPPA (<i>Alternate</i>)
Scientific and Industrial Testing and Research Centre, Coimbatore	SHRI A. M. SELVARAJ DR K. ULAGANATHAN SHRI V. KRISHNAMOORTHY (<i>Alternate</i>)

<i>Organization</i>	<i>Representative(s)</i>
Siemens Limited, Mumbai	SHRI PRADEEP RANADE SHRI ASHISH SHERE (<i>Alternate I</i>) SHRI PRASAD HARDIKAR (<i>Alternate II</i>)
Southern India Engineering Manufacturers Association, Coimbatore	DR R. SUBRAMANIAN SHRI S. ARUNKUMAR (<i>Alternate</i>)
Thyssenkrupp Industrial Solutions (India) Private Limited, Mumbai	MS CHARUTA VIKRAM MULAY SHRI VAJNATH G. SANGEKAR (<i>Alternate</i>)
Toshiba Mitsubishi-Electric Industrial Systems Corporation, Bengaluru	SHRI SUDHEER TAPASKAR SHRI MANISH JOSHI (<i>Alternate I</i>) SHRI VENKATESULU THUMBUR (<i>Alternate II</i>)
BIS Directorate General	SHRI ASIT KUMAR MAHARANA SCIENTIST 'E'/ DIRECTOR AND HEAD (ELECTROTECHNICAL) [REPRESENTING DIRECTOR GENERAL (<i>Ex-officio</i>)]

Member Secretary
SHRI JATIN TIWARI
SCIENTIST 'B'/ASSISTANT DIRECTOR
(ELECTROTECHNICAL), BIS

Bureau of Indian Standards

BIS is a statutory institution established under the *Bureau of Indian Standards Act, 2016* to promote harmonious development of the activities of standardization, marking and quality certification of goods and attending to connected matters in the country.

Copyright

BIS has the copyright of all its publications. No part of these publications may be reproduced in any form without the prior permission in writing of BIS. This does not preclude the free use, in the course of implementing the standard, of necessary details, such as symbols and sizes, type or grade designations. Enquiries relating to copyright be addressed to the Head (Publication & Sales), BIS.

Review of Indian Standards

Amendments are issued to standards as the need arises on the basis of comments. Standards are also reviewed periodically; a standard along with amendments is reaffirmed when such review indicates that no changes are needed; if the review indicates that changes are needed, it is taken up for revision. Users of Indian Standards should ascertain that they are in possession of the latest amendments or edition by referring to the website-www.bis.gov.in or www.standardsbis.in.

This Indian Standard has been developed from Doc No.: ETD 15 (23815).

Amendments Issued Since Publication

Amend No.	Date of Issue	Text Affected

BUREAU OF INDIAN STANDARDS

Headquarters:

Manak Bhavan, 9 Bahadur Shah Zafar Marg, New Delhi 110002

Telephones: 2323 0131, 2323 3375, 2323 9402

Website: www.bis.gov.in

Regional Offices:

Central : 601/A, Konnectus Tower -1, 6th Floor,
DMRC Building, Bhavbhuti Marg, New
Delhi 110002

Telephones

{ 2323 7617

Eastern : 8th Floor, Plot No 7/7 & 7/8, CP Block, Sector V,
Salt Lake, Kolkata, West Bengal 700091

{ 2367 0012
{ 2320 9474

Northern : Plot No. 4-A, Sector 27-B, Madhya Marg,
Chandigarh 160019

{ 265 9930

Southern : C.I.T. Campus, IV Cross Road, Taramani, Chennai 600113

{ 2254 1442
{ 2254 1216

Western : 5th Floor/MTNL CETTM, Technology Street, Hiranandani Gardens, Powai,
Mumbai 400076

{ 2570 0030
{ 2570 2715

Branches : AHMEDABAD, BENGALURU, BHOPAL, BHUBANESHWAR, CHANDIGARH, CHENNAI, COIMBATORE, DEHRADUN, DELHI, FARIDABAD, GHAZIABAD, GUWAHATI, HARYANA (CHANDIGARH), HUBLI, HYDERABAD, JAIPUR, JAMMU, JAMSHEDPUR, KOCHI, KOLKATA, LUCKNOW, MADURAI, MUMBAI, NAGPUR, NOIDA, PARWANOO, PATNA, PUNE, RAIPUR, RAJKOT, SURAT, VIJAYAWADA.