टेरिथेलिक एसिड — विशिष्टि
(पहला पुनरीक्षण)

Terephthalic Acid — Specification
(*First Revision*)

ICS 71.080.40

© BIS 2022



भारतीय मानक ब्यूरो
BUREAU OF INDIAN STANDARDS
मानक भवन, 9 बहादुर शाह ज़फर मार्ग, नई दिल्ली - 110002
MANAK BHAVAN, 9 BAHADUR SHAH ZAFAR MARG
NEW DELHI - 110002

www.bis.gov.in www.standardsbis.in

FOREWORD

This Indian Standard (First Revision) was adopted by the Bureau of Indian Standards, after the draft finalized by the Organic Chemicals, Alcohols and Allied Products Sectional Committee had been approved by the Petroleum, Coal and Related Products Division Council.

Terephthalic acid ($C_8H_6O_4$) is derived by oxidation of *p*-xylene using soluble bromide, metal acetates and acetic acid solvent. It is also commercially known as *p*-phthalic acid; benzene-*p*-dicarboxylic acid or 1,4-benzenedicarboxylic acid. It is represented by the following structural and molecule formulae:

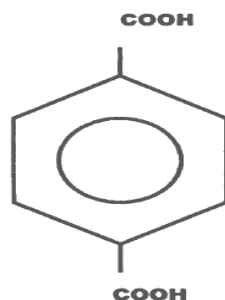

Molecular weight : 166

[Molecular formula : $C_6H_4(COOH)_2$]

It is used in the production of synthetic resins, fibers and films by combination with glycols. The presence of *p*-toluic acid (*p*-TA), 4-carboxybenzaldehyde (4-CBA) and benzoic acid (BA) in pure terephthalic acid (PTA) used for the production of polyester is undesirable because they can slow down the polymerization process and 4-carboxybenzaldehyde (4-CBA) imparts coloration to the polymer due to thermal instability. Since the reaction medium is highly corrosive hence, anticorrosive reactors like titanium clad reactors are generally used.

Terephthalic Acid can affect, when breathed in. Contact can irritate the skin and eyes. Breathing Terephthalic Acid can irritate the nose, throat and lungs causing coughing, wheezing and/or shortness of breath.

The standard was first published in 2001. In this (*first*) revision, test methods for determination of colour, determination of ash and determination of Acid Value have been modified, based on the latest technologies. HPLC method for determination of 4-carboxybenzaldehyde (4-CBA) and *p*-toluic acid (*p*-TA) content has also been modified. Normal voltage mode capillary electrophoresis test method for the determination of *p*-toluic acid, 4-carboxybenzaldehyde and benzoic acid in purified terephthalic acid and test method for determination of titanium in Annex E have been incorporated. Amendment no. 1 to IS 15030 : 2001 has been incorporated in this revision.

Considerable assistance has been taken from the following test methods:

- a) ASTM D 7882 for determination of *p*-toluic acid (*p*-TA) and 4-carboxybenzaldehyde (4-CBA) in purified terephthalic acid (PTA) by normal voltage mode capillary electrophoresis; and
- b) ASTM D 7884 for determination of *p*-toluic acid (*p*-TA) and 4-carboxybenzaldehyde (4-CBA) in purified terephthalic acid (PTA) by high performance liquid chromatography.

The composition of the Committee responsible for the formulation of this standard is given at Annex L.

For the purpose of deciding whether a particular requirement of this standard is complied with, the final value, observed or calculated, expressing the result of a test or analysis, shall be rounded off in accordance with IS 2 : 2022 'Rules for rounding off numerical values (*second revision*). The number of significant places retained in the rounded off value should be the same as that of the specified value in this standard.

Indian Standard

TEREPHTHALIC ACID — SPECIFICATION

(First Revision)

1 SCOPE

This standard prescribes requirements, the methods of sampling and test for pure terephthalic acid.

2 REFERENCES

The following standards contain provisions which through reference in this text, constitute the provisions of this standard. At the time of publication, the editions indicated were valid. All standards are subject to revision and parties to agreements based on this standard are encouraged to investigate the possibility of applying the most recent editions of the standard indicated below:

<i>IS No.</i>	<i>Title</i>
265 : 2021	Hydrochloric acid — Specification (<i>fifth revision</i>)
266 : 1993	Sulphuric acid — Specification (<i>third revision</i>)
460 (Part 1) : 2020	Test Sieves — Specification: Part 1 Wire Cloth Test Sieves (<i>fourth revision</i>)
915 : 2012	Laboratory glassware — One - mark volumetric flasks (<i>third revision</i>)
1070 : 1992	Reagent grade water — Specification (<i>third revision</i>)

<i>IS No.</i>	<i>Title</i>
2362 : 1993	Determination of water by karl fischer method — Test method (<i>second revision</i>)

4161 : 1967	Specification for nessler cylinders
----------------	-------------------------------------

3 REQUIREMENTS**3.1 Description**

The material shall be in the form of white crystalline free flowing powder and free from extraneous impurities like dust and dirt. Terephthalic is insoluble in water, chloroform, ether, acetic acid but slightly soluble in alcohol and completely soluble in alkalis.

3.2 The material shall also comply with the requirements given in Table 1, when tested in accordance with the methods referred in col 4 of the Table 1.

3.3 b* Value

b* value shall be determined as agreement between the purchase and the supplier.

NOTE — b* value represents the colour imparting multi-ring species which have an important impact on polyester process in terms of product colour and glow and thus is a key parameter for polyester process.

Table 1 Requirements for Terephthalic Acid
(Clause 3.2 and 7.1)

SI No.	Characteristic	Requirement	Method of Test, Ref to Annex
(1)	(2)	(3)	(4)
i)	Moisture content, percent by weight, <i>Max</i>	0.2	A
ii)	Colour, Pt-Co, <i>Max</i>	10	B
iii)	Ash content, ppm, <i>Max</i>	10	C
iv)	Acid value, mg KOH/g	675 ± 2	D
v)	Total of iron, cobalt, manganese, chromium and titanium, ppm, <i>Max</i>	5 (each not greater than 1 ppm)	E / G
vi)	Total of sodium, magnesium, potassium, calcium and nickel, ppm, <i>Max</i>	5 (each not greater than 1 ppm)	F / G
vii)	4-carboxybenzaldehyde, ppm, <i>Max</i>	25	H
viii)	4-carboxybenzaldehyde + <i>p</i> -toluic acid, ppm, <i>Max</i>	195	H

4 PRECAUTIONS IN HANDLING

Terephthalic acid has very low toxicity. The use of dust masks is advisable when handling terephthalic acid. Finely divided organic products which are combustible are liable to explosion should the dust content of the atmosphere be high and if ignition occurs. Good housekeeping is, therefore, advisable to minimize the amount of dust when terephthalic acid is handled. The atmosphere of any silo or pneumatic transfer equipment where dust explosions could occur should be blanketed with inert gas to below 10 volume percent oxygen content.

5 PACKING AND MARKING

5.1 The material shall be supplied in bulk containers of 1 000 kg in flexible woven plastic or packages as agreed to between the purchaser and the supplier.

5.2 Marking

5.2.1 The packages shall be marked with the following:

- a) Name of the material,
- b) Name of manufacturer and his recognized trade-mark, if any;
- c) Month and year of manufacture;
- d) Net mass of the material in the container;

- e) Lot or batch number; and
- f) Any other statutory requirements.

5.2.2 BIS Certification Marking

The product(s) conforming to the requirements of this standard may be certified as per the conformity assessment schemes under the provisions of the *Bureau of Indian Standards Act, 2016* and the Rules and Regulations framed thereunder, and the products may be marked with the Standard Mark.

6 SAMPLING

The method of drawing representative samples of the material and the criteria for conformity shall be as prescribed in 4 of IS 5299.

7 TEST METHODS

7.1 Tests shall be conducted according to the method of test referred in col 4 of Table 1.

7.2 Quality of Reagents

Unless specified otherwise, 'pure chemicals' and distilled water (*see* IS 1070) shall be used in tests.

NOTE — 'Pure chemicals' shall mean chemicals that do not contain impurities, which affect the results of analysis.

ANNEX A

[Table 1, Sl No. (i)]

DETERMINATION OF MOISTURE CONTENT**A-1 GENERAL**

Moisture content is determined by using the karl fischer method.

A-2 PROCEDURE

Take about 2 g of the material and determine the moisture content by karl fischer method as described in IS 2362

NOTE — Any other solvent system with appropriate ratio may be used for complete dissolution of pure terephthalic acid (PTA) while preparing the sample as prescribed in IS 2362.

ANNEX B

[Table 1, Sl No. (ii)]

DETERMINATION OF COLOUR**B-1 GENERAL**

Three methods namely, Methods A and C for determination of colour by visual comparison and Method B for determination of colour by tristimulus spectrophotometric method have been prescribed. In case of disputes, method B shall be the referee method.

B-2 METHOD A**B-2.1 General**

Colour of terephthalic acid solution in potassium hydroxide solution is measured using 2 M potassium hydroxide solution as reference on Pt-Co colour scale.

B-2.2 Reagents

B-2.2.1 *Potassium Hydroxide*, AR grade.

B-2.2.2 *Potassium Hydroxide Solution*, 2 M.

Take 56 g potassium hydroxide in 250 ml beaker and dissolve in distilled water. Transfer content in to 500 ml volumetric flask and makeup the volume up to 500 ml.

NOTE — N, N-Dimethylformamide may be used as a blank in place of 2 M potassium hydroxide solution.

B-2.3 Procedure

Take 75 ml of 2 M potassium hydroxide solution in 250 ml beaker and add magnetic stirrer bar. Slowly start stirring without splashing potassium hydroxide solution. Carefully add 10 ± 0.1 g terephthalic acid slowly to beaker. Continue stirring till terephthalic acid is completely dissolved.

Measure colour of terephthalic acid solution using 2 M potassium hydroxide as blank by IS 8768 test method.

Report colour as per IS 8768 test method.

NOTE — Nessler tube of appropriate height may be used for testing as per IS 8768

B-3 METHOD B**B-3.1 Outline of the Method**

The sample is dissolved in aqueous potassium hydroxide and the colour of the solution is measured in Pt-Co units by using automatic tintometer that is tristimulus spectrophotometric method.

B-3.2 Reagents

B-3.2.1 *Potassium Hydroxide Solution*, 2 N aqueous.

B-3.3 Apparatus

B-3.3.1 *Automatic Tintometer*

B-3.4 Calibration

Prepare the instrument by following the instrument manufacturer's instructions. Obtain a Pt-Co value of 0 for a sample of distilled water by instrument standardizing adjustments or program. It is advisable to read back distilled water to verify that the instrument reads a Pt-Co value of 0. Run quality assurance samples to verify the analytical system is in control.

B-3.5 Procedure

Take 75 ml of 2 N potassium hydroxide solution into a 250 ml beaker. Carefully, add 10.0 g of sample to it, with constant stirring to ensure complete dissolution.

Measure the colour of solution by using 50 mm cell in automatic tintometer in Pt-Co colour mode.

Testing of blank shall be done by using 2 N potassium hydroxide solution.

NOTE — For effective mixing other tools like magnetic stirrer and sonication may be used.

B-4 METHOD C

B-4.1 Outline of the Method

The colour of 5 percent solution of terephthalic acid in N, N-dimethylformamide is compared with that of the colour standard and expressed in terms of Pt-Co units.

B-4.2 Apparatus

B-4.2.1 Nessler Cylinder, two cylinder with 100 ml capacity each (see IS 4161).

B-4.2.2 One-Mark Volumetric Flasks, 250 ml and 500 ml capacities (see IS 915).

B-4.2.3 Erlenmeyer Flask, 250 ml.

B-4.3 Reagents

B-4.3.1 Cobaltous Chloride Hexahydrate, solid.

B-4.3.2 Concentrated Hydrochloric Acid (see IS 265).

B-4.3.3 Chloroplatinic Acid

Dissolve 250 mg of platinum in small quantity of aqua regia contained in a glass or porcelain dish by heating on a water-bath. When the metal has dissolved, evaporate the solution to dryness. Add 1

ml of hydrochloric acid and again evaporate to dryness. Repeat this operation twice.

B-4.3.4 N,N-Dimethylformamide

B-4.4 Preparation of Colour Standard

B-4.4.1 Dissolve 0.50 g of cobalt chloride hexahydrate and whole of the chloroplatinic acid (see **B-4.3.3**) in 50 ml of the hydrochloric acid. Warm, if necessary, to obtain a clear solution and after cooling, pour it into the 500 ml one-mark graduated flask. Dilute with water to the mark. This solution has a colour of 500 Pt-Co units.

NOTE — Alternatively certified readymade standard may also be used.

B-4.4.2 Pipette 5 ml of the solution (**B-4.4.1**) into a 250 ml one-mark graduated flask and dilute with water to the mark. The diluted solution corresponds to a colour of 10 Pt-Co units and should always be freshly prepared.

B-4.5 Procedure

Weigh accurately 5.0 g of the material into a 250 ml erlenmeyer flask and add 100 ± 0.5 ml of N, N-dimethylformamide. Shake the stoppered flask until all of the sample is dissolved. Transfer the solution into a nessler cylinder and compare the colour against a white background with the colour standard taken in the other nessler cylinder. The material shall be taken to have passed the test if the colour of the sample solution is not darker than that of the colour standard.

ANNEX C
[Table 1, Sl No. (iii)]

DETERMINATION OF ASH

C-1 APPARATUS

C-1.1 Muffle Furnace / Microwave Furnace

C-1.2 Bunsen Burner, gas based or electric.

C-1.3 Crucible, made of platinum or quartz or silica, 50 ml, or any suitable size.

C-1.4 Analytical Balance

C-1.5 Crucible Tongs, made of stainless steel with platinum tips.

C-1.6 Glazed Porcelain Plates

C-1.7 Clean glass beaker, 500 ml capacity.

C-2 PROCEDURE

C-2.1 Conditioning of Crucible

Clean the crucible free from grease and salts by soaking in hot chromic acid or any other suitable acid, followed by distilled water. Place the crucible in the muffle furnace / microwave furnace kept at 750°C with the help of platinum tipped crucible tongs for 30 min or till constant weight is achieved. Remove the crucible from the furnace and place it on a clean porcelain plate which is free of dust particles. Allow the crucible to cool for 1 min and transfer it to a desiccator which is placed near the analytical balance.

Take the mass of the empty crucible nearest to 0.1 mg.

C-2.2 Sample for Ashing

Take 500 ml capacity clean and dry beaker. Take around 100 ± 50 g of terephthalic acid sample in beaker for ashing. Take mass of the beaker with terephthalic acid nearest to 0.1 g (W_2). Use terephthalic acid in the beaker for ashing. After complete transfer of terephthalic acid for ashing in crucible further take mass of the beaker (W_1).

C-2.3 Sample Carbonization

Place the pre-weighted crucible on a triangle supported by a tripod on Bunsen burner preferably in fume hood. Light Bunsen burner and allow to heat crucible. Add small quantity about 5-10 g of sample from beaker (C-2.2) and carbonize terephthalic sample. Continue adding terephthalic acid sample step by step to crucible till whole quantity of terephthalic acid sample is carbonized.

C-2.4 Ashing of Terephthalic Acid Carbonized Residue

After complete carbonization of whole terephthalic acid sample in crucible, keep the crucible in muffle furnace / microwave furnace kept at 750°C for minimum 1 h or till ashing is completed. All carbons must be removed during ashing process. Remove the crucible from the furnace and place it with ash in the desiccator for 30 min. Take the mass of the crucible and its contents nearest to 0.1 mg.

NOTES

1 External carbonization of terephthalic is not required when using temperature programmable microwave furnace. Many laboratories don't use open flame inside laboratory for safety reason, programmable microwave furnace will provide options for such laboratories.

2 A minimum of 100 ± 50 g of sample is to be incinerated.

3 Once the sample has been reduced to a carbonaceous ash, extreme care must be exercised in handling the crucible. If the crucible is handled in the usual manner with the tongs, carbon may be transferred to the tips of the tongs and may add carbon to the ash when the crucible is removed from the furnace. In order to prevent this source of serious error, turn the tongs with tips pointing upward and pick up the crucible by placing the arcs of the tongs around the body of the crucible. The crucible should not make contact with the refractory lining of the furnace as particles of platinum may be scratched off thus changing its mass.

C-3 CALCULATION

$$\text{Ash, ppm} = \frac{M_3 - M_1}{M_2 - M_1} \times 10^6$$

where

- M_1 = mass of empty crucible, g;
- M_2 = mass of crucible plus terephthalic acid, g; and
- M_3 = mass of crucible with ash, g.

Or

$$\text{Ash, ppm} = \frac{M_3 - M_1}{W_2 - W_1} \times 10^6$$

where

- M_1 = mass of empty crucible, g;
- M_3 = mass of crucible with ash, g;
- W_1 = mass of empty beaker, g; and
- W_2 = mass of beaker plus terephthalic acid, g.

C-4 REPORT

Report ash in terephthalic acid nearest to 1 ppm.

ANNEX D

[Table 1, Sl No. (iv)]

DETERMINATION OF ACID VALUE**D-1 GENERAL**

The material is dissolved in pyridine or dimethyl sulfoxide or dimethylformamide, diluted with water and titrated with aqueous sodium hydroxide to phenolphthalein end point.

D-2 REAGENTS

D-2.1 Pyridine or Dimethyl Sulfoxide or Dimethylformamide, AR grade.

D-2.2 Phenolphthalein, 1 percent solution in ethanol (or other suitable alcohol).

D-2.3 Sodium Hydroxide, 0.5 M aqueous solution or lower concentration standard solution.

D-2.4 Distilled Water, free from mineral acidity.

D-3 PROCEDURE

D-3.1 Weigh about 0.4-1.5 g of the material into a 100 ml beaker. Add 20 ± 0.5 ml of pyridine or dimethyl sulfoxide or dimethylformamide solvent and stir until all the sample is dissolved. Add 20 ± 1 ml of carbon dioxide (CO₂) free distilled water and two drops of phenolphthalein indicator. Titrate with 0.5 M sodium hydroxide solution or lower

concentration standard solution to a permanent pink end point. Carry out a blank determination simultaneously excluding the material.

D-3.2 Auto titrator using pH electrode may also be used to carry out titration

D-4 CALCULATION

Acid value, mg KOH/g =

$$\frac{(V_1 - V_2) \times M \times 56.11}{W}$$

where

V_1 = volume of sodium hydroxide consumed with sample, ml;

V_2 = volume of sodium hydroxide consumed with blank, ml;

M = molarity of sodium hydroxide; and

W = mass of sample taken for the test.

ANNEX E

[Table 1, Sl No. (v)]

DETERMINATION OF IRON, COBALT, MANGANESE, CHROMIUM AND TITANIUM**E-1 GENERAL**

The material is ashed in two separate dishes in presence of sulphuric acid. Ash in one dish is dissolved in concentrated hydrochloric acid and cobalt and manganese and titanium are determined by atomic absorption spectrophotometric method. Ash in the other dish is fused with potassium hydrogen sulphate, dissolved in concentrated hydrochloric acid and iron and chromium are determined by atomic absorption spectrophotometric method. In both cases air/acetylene flame is used.

E-2 APPARATUS**E-2.1 Atomic Absorption Spectrophotometer (AAS)**

For determination of these elements using AAS, details of test methods as given in relevant Indian Standard (*see* Annex J) may be referred. Typical working conditions of AAS are given below for guidance only:

	<i>Iron</i>	<i>Cobalt</i>	<i>Manganese</i>	<i>Chromium</i>	<i>Titanium</i>
Wavelength, nm	248.3	240.7	279.5	357.9	364.3
HV	700	620	620	460	460

Band pass	0.3	0.3	0.3	0.3	0.5
Air	16	16	16	16	16
Fuel (acetylene)	6	6	6	6	6
Burner height, mm	8	7	5	8	8
Lamp current, mA	7	7	3	5	20
Scale expansion	1	2	1	2	2
Burner angle	0	0	0	0	0

E-3 REAGENTS

E-3.1 Concentrated Hydrochloric Acid (*see* IS 265).

E-3.2 Concentrated Sulphuric Acid (*see* IS 266).

E-3.3 Potassium Hydrogen Sulphate, fine powder.

E-3.4 Stock Iron Solution, 1 000 ppm (*m/v*).

E-3.5 Stock Cobalt Solution, 1 000 ppm (*m/v*).

E-3.6 Stock Manganese Solution, 1 000 ppm (*m/v*).

E-3.7 Stock Chromium Solution, 1 000 ppm (*m/v*).

E-3.8 Stock Titanium Solution, 1 000 ppm (*m/v*).

E-4 PREPARATION OF STANDARD SOLUTIONS

E-4.1 Standard Working Solutions

Pipette 10.0 ml of each of the stock solutions (**E-3.4** to **E-3.8**) into a 1 000 ml flask and make up to the mark to give 10 ppm (*m/v*) standard working solutions. These shall be prepared fresh every time before testing.

E-4.1.1 Standard Iron, Chromium and Titanium solutions

Take 5, 10, 15 and 20 ml of standard working solutions of iron, chromium and titanium of 10 ppm (*m/v*) (**E-4.1**) in each of four 100 ml volumetric flasks. Add 1 g of ground potassium hydrogen sulphate and 5 percent hydrochloric acid and shake to dissolve. Dilute to the mark with 5 percent hydrochloric acid (HCl) to give standard solutions containing 0.5, 1.0, 1.5 and 2.0 ppm (*m/v*) of iron, chromium and titanium.

E-4.1.2 Standard Cobalt and Manganese Solutions

Take 5, 10, 15 and 20 ml of both standard working solutions of cobalt and manganese of 10 ppm (*m/v*) (**E-4.1**) in each of four 100 ml volumetric flasks. Make up to the mark with 5 percent hydrochloric acid (HCl) and shake well. This gives standard

solutions containing 0.5, 1.0, 1.5 and 2.0 ppm (*m/v*) of cobalt and manganese.

E-5 PROCEDURE

E-5.1 Weigh accurately about 25 g of sample into two separate silica (or platinum or quartz) dishes. Wet thoroughly with 5 ml of concentrated sulphuric acid and char completely under a vertical heater or by using hot plate. Place the dishes in the entrance of a muffle furnace with the door open, and fume until most of the carbon has been removed. Move the dishes further into the muffle furnace, close the door gently and leave until all the carbon has been removed. Care shall be taken that the sample does not ignite.

E-5.2 Add 5 ml of concentrated hydrochloric acid to one of the dishes, warm, if necessary, to dissolve and transfer quantitatively to a 100 ml volumetric flask. Make up to the mark with water. Run through in following order; respective standards; samples and standards again for cobalt and manganese using given conditions (*see* **E-2.1**).

E-5.3 Fuse the residue from the other dish with 1.00 g of ground potassium hydrogen sulphate (KHSO₄) and a few drops of concentrated sulphuric acid over a bunsen burner or hot plate. Cool and add 5 ml of concentrated hydrochloric acid, warm, if necessary to dissolve and transfer quantitatively to a 100 ml volumetric flask and make up to the mark with water. Prepare a blank by taking 1.0 g of ground potassium hydrogen sulphate (KHSO₄) and a few drops of concentrated sulphuric acid. Run through in following order : respective standards; blank samples and standards again for iron and chromium and titanium, using the given conditions (*see* **E-2.1**).

E-6 CALCULATION

The respective metals (that is iron, chromium, titanium, cobalt, manganese), ppm = $\frac{C_1 \times 100}{M}$

where

C_1 = Iron/cobalt/chromium/ manganese/
titanium content in solution
derived from sample, ppm; and

M = mass of the sample taken for test, g.

ANNEX F
[Table 1, Sl No. (vi)]

DETERMINATION OF SODIUM, MAGNESIUM, POTASSIUM, CALCIUM AND NICKEL

F-1 PRINCIPLE

The sample is ashed in the presence of sulphuric acid. The ash is dissolved in concentrated hydrochloric acid. Concentration of sodium, potassium, and nickel are determined by atomic absorption spectrophotometry in an air/acetylene flame. Concentration of calcium and magnesium are determined by atomic absorption spectrophotometry in a nitrous oxide/acetylene flame.

F-2 APPARATUS

F-2.1 Atomic Absorption Spectrophotometer

For determination of these elements using AAS, details of test methods as given in relevant Indian Standard (*see* Annex J) may be referred. Typical conditions only for guidance are given below. The wavelengths given are the true atomic line wavelengths and may not correspond exactly to the wavelength dial of the instrument

	<i>Sodium</i>	<i>Nickel</i>	<i>Calcium</i>	<i>Magnesium</i>	<i>Potassium</i>
Wavelength, nm	589.6	232.0	422.7	285.2	766.5
Band pass, nm	0.5	0.15	0.5	0.5	2
Burner height, nm	7	7	7	7	7
Oxidant air	Air	N ₂ O	N ₂ O	N ₂ O	N ₂ O
Lamp current, mA	4	7	5	4	*
HV	530	700	530	460	800
Integration time, s	1	1	1	1	1

*Emission mode

F-3 REAGENTS

F-3.1 Hydrochloric Acid (*see* IS 265).

F-3.2 Sulphuric Acid (*see* IS 266).

F-3.3 Stock Sodium Solution, 1 000 ppm (*m/v*).

F-3.4 Stock Potassium Solution, 1 000 ppm (*m/v*).

F-3.5 Stock Calcium Solution, 1 000 ppm (*m/v*).

F-3.6 Stock Magnesium Solution, 1 000 ppm (*m/v*).

F-3.7 Stock Nickel Solution, 1 000 ppm (*m/v*).

F-4 PREPARATION OF STANDARD SOLUTIONS

F-4.1 Standard Working Solutions

Pipette 10 ml of each of the stock solutions (**F-3.3** to **F-3.7**) into 1 000 ml flask and dilute each to the mark to give 10 ppm (*m/v*) of standard working solution. These shall be prepared fresh every day before testing.

F-4.1.1 Standard Sodium, Potassium, Calcium, Magnesium and Nickel Solutions

Take 10 ml concentrated hydrochloric acid into each of the five 100 ml volumetric flasks. Add by means of pipette 2, 5, 10, 20 and 50 ml of each of the standard working solutions (*see* **F-4.1**) into each of the volumetric flasks and dilute to the mark with water to give standard solutions of 0.2, 0.5, 1.0, 2.0 and 5.0 ppm (*m/v*) of each of the elements. Prepare a zero-standard solution by pipetting 10 ml of concentrated hydrochloric acid into a 100 ml volumetric flask and diluting to the mark with demineralized water.

F-5 PROCEDURE

F-5.1 Weigh accurately about 25 g of sample into a silica dish. Wet thoroughly with 5 ml of concentrated sulphuric acid and char completely on a temperature-controlled heater or microwave oven/furnace. Prepare a blank by adding 5 ml of concentrated sulphuric acid to a silica dish and evaporate on a temperature controlled heater. Place the dishes into a muffle furnace at 550°C, close the door and leave until all the carbon has been removed. Care shall be taken that the sample does not ignite. Remove the dishes, cover with a watch glass and cool. Add 2.5 ml of concentrated hydrochloric acid to each dish, cover with a watch glass and place each dish on hot plate to simmer for 5 min. Cool and dilute the sample with 10 ml of demineralized water. Transfer the sample and blank to two 25 ml volumetric flasks and dilute to the mark with water.

F-5.2 Using the absorption mode of the instrument determine sodium, calcium, magnesium, and nickel on the sample and blank against the prepared standards.

F-5.3 Using the emission mode of the instrument determine potassium on the sample and blank.

F-6 CALCULATION

Respective metal content, ppm =

$$\frac{25 \times (C_1 - C_2)}{W}$$

where

C_1 = concentration of sodium/ calcium/ magnesium/ nickel / potassium in sample solution, ppm;

C_2 = concentration of sodium/ calcium/ magnesium/ nickel/ potassium in blank, ppm; and

W = mass of sample taken for test, g.

ANNEX G

[Table 1, *Sl No.* (v) and (vi)]

METAL ANALYSIS IN TEREPHTHALIC ACID BY ICP-OES TECHNIQUE**G-1 GENERAL**

G-1.1 This test method covers determination of iron, cobalt, manganese, chromium, titanium, sodium, magnesium, potassium, calcium and nickel in the concentration range of 0.1 mg/kg to 10 mg/kg in terephthalic acid by inductively coupled plasma optical emission spectrometry method (ICP-OES). Higher metal content may also be analyzed by ICP-AES method by appropriate dilution.

NOTE — ICP-OES and ICP-AES is synonym of analytical technique.

G-2 OUTLINE OF THE TEST METHOD

Terephthalic acid sample is either dissolved in ammonium hydroxide or ashed, fused, digested and dissolved in aqueous solution. Metals are analyzed by internal standard method. Alternatively, metals can also be analyzed by external calibration technique.

After dilution, the solution is aspirated into the plasma of an inductively coupled plasma emission spectrometer and emission radiation of the resonance lines of the elements under analysis is

measured and compared with a curve constructed from standard calibration solution.

G-3 APPARATUS

G-3.1 Analytical Balance, minimum capacity 200 g capable of weighing to the nearest 0.1 mg.

G-3.2 Inductively Coupled Plasma Atomic Emission Spectrometer

Either a sequential or simultaneous spectrometer is suitable, if equipped with a quartz inductively coupled plasma (ICP) torch and radio frequency (RF) generator to form and sustain the plasma.

G-3.3 Nebulizer, reduces the possibility of clogging and minimizes aerosol particle effects. Any manufacturer's recommend suitable nebulizer may be used.

G-3.4 Peristaltic Pump

A peristaltic pump is recommended to provide a constant flow of solution. The pumping speed shall be in the range of 0.5 to 3 ml/min. The pump tubing shall withstand at least 6 h exposure to the dilution

solvent. Alternatively, any latest peristaltic pump with instrument suppliers' specification may also be used.

G-3.5 Crucible/Dish, made of platinum or silica or quartz, 50 ml capacity, minimum.

G-3.6 Hot Plate, with or without magnetic stirring capability.

G-3.7 Muffle Furnace or Microwave Muffle Furnace, capable of being maintained at temperatures of $(750 \pm 25)^\circ\text{C}$.

G-4 REAGENTS

G-4.1 Distilled Water/Ultrapure Water, for dilution of certified reference material (CRM) for preparation of the calibration standards/samples and for use as blank.

G-4.2 Hydrochloric Acid, concentrated, 36 percent purity, minimum.

G-4.3 Sulphuric Acid, concentrated 98 percent purity, minimum.

G-4.4 Nitric Acid

G-4.5 Internal Standard, yttrium or scandium (or any suitable metal) is used for internal standardization.

G-4.6 Single or Multi Element Certified Reference Material (Standard)

G-4.7 Di-lithium-tetraborate

G-4.8 High Purity Argon Gas, analytical grade, purity 99.99 percent, minimum.

G-4.9 Ammonia Solution, 25 percent, minimum.

NOTE — Analytical grade chemicals shall be used. It is intended that all reagents conform to the metal-free and the reagent is of sufficiently high purity to permit its use without lessening the accuracy of the determination.

G-5 SAMPLE AND STANDARD PREPARATION

G-5.1 Sample preparation

Terephthalic acid sample is either dissolved in ammonium hydroxide (*see* G-5.1.1) or ashed/fused/digested (*see* G-5.1.2.1 or G-5.1.2.2) and dissolved in aqueous solution. Metals are analyzed by internal standard method.

G-5.1.1 Terephthalic acid sample dissolution in ammonium hydroxide solution

G-5.1.1 Terephthalic acid sample dissolution in ammonium hydroxide solution

G-5.1.1.1 Take 3-7 g of PTA powder in 100 ml volumetric flask, add 15-20 ml of water, 0.2 ppm yttrium (as internal standard) and 4-15 ml of ammonia solution (25-30 percent) solution. Sonicate till complete powder is dissolved. Make up the solution up to 100 ml with distilled water.

G-5.1.1.2 To prepare blank solution, follow the above procedure (*see* G-5.1.1.1) except addition of PTA powder.

G-5.1.2 Terephthalic acid sample is ashed and dissolved in aqueous solution

5.1.2.1 *Ashing followed by fusing and digestion by using microwave furnace/ muffle furnace followed by ICP-OES*

G-5.1.2.1.1 Weigh accurately about 100 g of sample (or appropriate quantity suitable for precise metal analysis) in crucible/dish. Wet thoroughly with about 5-10 ml of concentrated sulphuric acid and char completely by keeping crucible/dish on hot plate at low heat for about 5-10 min. Place the crucible/dish in the microwave furnace/ muffle furnace until all the carbon has been completely removed. Remove crucible/dish from furnace and cool in desiccator.

G-5.1.2.1.2 Fuse the residue from the crucible/dish with 1 g of ground di-lithium-tetraborate and a few drops of concentrated sulphuric acid over a bunsen burner or hot plate. Cool and add 5 ml of concentrated hydrochloric acid, warm, if necessary to dissolve and transfer quantitatively to a 100 ml volumetric flask and make it up to the mark with distilled water and analyze by ICP-OES.

G-5.1.2.1.3 Prepare a blank by taking 1.0 g of ground di-lithium-tetraborate and a few drops of concentrated sulphuric acid.

G-5.1.2.2 *Ashing by using microwave furnace/ muffle furnace followed by ICP-OES*

Place 75 ± 25 g of PTA in the crucible/dish. Weigh the crucible/dish and contents on the analytical balance to the nearest 0.1 g and record the net weight of the PTA. Place the dish in the microwave furnace/ muffle furnace for 1 h at 750°C until the entire black residue has been burned off. Dissolve PTA ash in nitric acid and transfer to a 100 ml volumetric flask and make it up to the mark with distilled water and analyze by ICP-OES.

G-5.2 Standard Preparation

Prepare minimum two matrix match calibration standard using either multi-element standard or single element standards and calibrate ICP

instrument. Calibration range should cover concentration of metal in sample solution.

If analysis is done by internal standard method, internal standard is added to the sample and standard solutions to compensate for variations in test specimen introduction efficiency. By comparing emission intensities measured with the standards, the concentrations of elements in the test specimen are calculated. Add 0.2 ppm yttrium (another

appropriate internal standard may also be used) as an internal standard in all matrix calibration standard include blank.

NOTE — Ensure that there should not be any precipitation in sample as well as in calibration standard. In case of ammonia dilution method, use of ammonium hydroxide is optional in calibration mixture.

Suggested Wavelengths for Various Elements

<i>Element</i> (1)	<i>Wavelength, nm</i> (2)
Iron	238.20, 259.94
Cobalt	228.615, 236.375, 238.892
Manganese	279.08, 279.55, 285.21
Chromium	205.55, 267.72
Titanium	334.94, 337.28, 350.50
Sodium	589.59
Magnesium	279.08, 279.55, 285.21
Potassium	766.49
Calcium	315.89, 317.93, 364.44, 422.67
Nickel	221.65, 227.02, 231.60

Internal Standards, Recommended Wavelengths

<i>Internal Standard</i> (1)	<i>Wavelength, nm</i> (2)
Scandium	361.383
Yttrium	371.029
Cadmium	228.802

NOTE — Internal standard concentration may be appropriately adjusted to get precise metal analysis results.

G-6 PROCEDURE

G-6.1 To operate ICP equipment, original equipment manufacturer (OEM) guidelines are to be followed. However, general guidelines to be followed are given as Annex K.

G-6.2 Turn on the gases, exhaust system and the chiller. Turn the main instrument on from ON/OFF button. Place the standard minimum two in number along with blank in standard tube of auto sampler. Place the desired samples to be analyzed in sample tray of auto sampler. Switch on computer, software

and plasma as per instrument manufacturer instruction.

NOTE — Manual sample injection may also be used.

G-7 SAMPLE ANALYSIS

Calibrate ICP instrument and analyze prepared samples as per instrument manufacturer's instructions.

G-8 CALCULATION

By compensating for the dilution mentioned within the sample information window, the software will automatically calculate the result. Use the instrument's operating instructions as a guide.

G-9 REPORT

Report the results in nearest to 0.1 weight ppm.

ANNEX H

[Table 1, Sl No. (vii) and (viii)]

DETERMINATION OF 4- CARBOXYBENZALDEHYDE (4-CBA) AND *p*-TOLUIC ACID (*p*-TA)

H-1 GENERAL

Four methods namely, Method A, Method B, Method C and Method D have been prescribed. Method A for the determination of 4-carboxybenzaldehyde (4-CBA) and *p*-toluic acid (*p*-TA) by high-performance liquid chromatography (HPLC) method, Method B for the determination of *p*-toluic acid (*p*-TA) in pure terephthalic acid by gas chromatographic (GC) method, Method C for the determination of 4-carboxybenzaldehyde (4-CBA) in pure terephthalic acid using polarographic analyzer and Method D for the determination of *p*-toluic acid (*p*-TA) and 4-carboxybenzaldehyde (4-CBA) in purified terephthalic acid (PTA) by normal voltage mode capillary electrophoresis (CE). Method A, Method C and Method D may be used for determination of 4-carboxybenzaldehyde (4-CBA) and Method A, Method B and Method D may be used for determination of *p*-toluic acid (*p*-TA).

H-2 METHOD A DETERMINATION OF 4-CARBOXYBENZALDEHYDE (4-CBA) AND *p*-TOLUIC ACID (*p*-TA) BY HPLC METHOD

H-2.1 General

4-Carboxybenzaldehyde (4-CBA) of concentration ranging from 2 to 500 ppm (w/w) and *p*-toluic acid (*p*-TA) of concentration ranging from 10 to 500 ppm (w/w) in purified terephthalic acid (PTA) is determined by reverse phase high performance liquid chromatography (HPLC).

H-2.2 Summary of Test Method

The PTA sample is dissolved in ammonium hydroxide solution and injected into a high-performance liquid chromatograph with a UV detector in a fixed volume. The impurities of *p*-TA and 4-CBA are separated from PTA using a C18 chemically bonded column. For quantification, an external standard calibration is used.

H-2.3 Apparatus

H-2.3.1 HPLC System, capable of pumping the mobile phase at flow rates between 0.1 and 2.0 ml/min, pressure between 0 and 40 MPa and a pulsation of less than 1 percent full scale deflection under the test conditions described in Table 2. The S/N (signal to noise) ratio should be greater than or equal to 3:1 for 2 ppm (w/w) 4-CBA and 10 ppm (w/w) *p*-TA.

Table 2 Suggested Operating Conditions
(Clause H-2.3.1)

Column	: C18
Stationary phase	: Octadecylsilane chemically bonded silica
Particle size	: 3 µm to 5 µm
Material of column	: stainless steel
Length of column	: 150 mm to 250 mm**
Inner diameter	: 4–5 mm
Mobile phase	: 0.06 percent phosphoric acid (H ₃ PO ₄) solution : acetonitrile (82 : 18)
Flow rate	: 1.0 ml/min or suitable flow program
UV detector	: 254 nm for 4-CBA 240 nm for <i>p</i> -TA
Injection amount	: 20 µl
Column temperature	: 40°C

** 250 mm column is found more suitable for proper separation of components.

H-2.3.2 Sample Injection System, capable of injecting 1 µl to 25 µl in partial or full loop mode.

H-2.3.3 Detector, variable wavelength ultraviolet photometric detector (VWD), multi-wavelength detector, or photometric diode array detector (PDA), capable of operating at 240 and 254 nm.

H-2.3.4 Column Oven, any suitable HPLC column oven (block heating or air circulating) capable of maintaining a constant temperature of ± 1°C within the range of 20 °C]to 70°C.

H-2.3.5 Chromatography Data System

H-2.3.6 HPLC Columns (see Table 2)

H-2.3.7 Analytical Balance, readable to ± 0.000 1 g.

H-2.3.8 Sample Filter, for the removal of particulate matter from the sample solution, a disposable syringe filter made of cellulose acetate, with a pore size between 0.22 and 0.45 μm , and is chemically inert to aqueous solutions, is recommended

H-2.4 Reagents

H-2.4.1 Ammonium Hydroxide (NH_4OH), 25 to 28 percent.

H-2.4.2 Phosphoric Acid (H_3PO_4), HPLC grade.

H-2.4.3 Acetonitrile, HPLC grade.

H-2.4.4 Water, HPLC grade.

H-2.4.5 Ammonium Hydroxide Solution

Take 1 volume of ammonium hydroxide and 1 volume of water.

H-2.4.6 PTA Standard for Calibration

A certified PTA calibration standard with known amounts of *p*-TA and 4-CBA is required. In case of non-availability of PTA calibrated standard, the concentrations of *p*-TA and 4-CBA in a PTA sample can be determined by procedure mentioned at **H-2.5**. The calibrated PTA sample may be used as a PTA calibration standard.

H-2.4.7 Mobile Phase

H-2.4.7.1 0.06 Percent Phosphoric Acid (H_3PO_4) solution : acetonitrile (82:18)

To make 0.06 percent phosphoric acid (H_3PO_4) solution, pipette 0.6 ml phosphoric acid into a 1 000 ml volumetric flask make up to the mark with water. Mix 820 ml of phosphoric acid solution and 180 ml of acetonitrile. In the mobile phase, methanol could be used instead of acetonitrile.

NOTE — Degassing and filtering of the mobile phase is recommended before use; degassing can be done on-line or off-line by helium sparging, vacuum degassing or ultrasonic agitation.

H-2.5 Procedure for Calibration of PTA Sample by Individual Components

H-2.5.1 To determine the concentrations of *p*-TA and 4-CBA, a PTA sample with granularity of 80 to 160 μm , containing 4-CBA and *p*-TA at concentrations of 10 to 25 ppm and 100 to 200 ppm, respectively, are to be analyzed. This PTA sample with calibrated concentrations of *p*-TA and 4-CBA can be used as the PTA standard for sample analysis.

H-2.5.2 Reagents

H-2.5.2.1 *p*-Toluic acid (*p*-TA), purity 98.0 percent, minimum.

H-2.5.2.2 4-Carboxybenzaldehyde (4-CBA), purity 98.0 percent, minimum.

H-2.5.3 4-CBA (10 $\mu\text{g/ml}$) Calibration Standard

Weigh about 0.025 0 g (to nearest 0.000 1 g) of 4-CBA in a 25 ml beaker, add water and a few drops of ammonium hydroxide solution, and stir until 4-CBA is completely dissolved. Using phosphoric acid solution, adjust the pH to 6-7. Accurately transfer the resulting solution to a 50 ml volumetric flask and dilute to the mark with water to make the concentration 500 ppm. Then dilute with water 50 times to 10 $\mu\text{g/ml}$.

H-2.5.4 *p*-TA (80 $\mu\text{g/ml}$, w/w) Calibration Standard

Weight about 0.020 0 g (to nearest 0.000 1 g) of *p*-TA and prepare 400 ppm *p*-TA standard solution as prepared in **H-2.5.3**. Then dilute with water to 80 $\mu\text{g/ml}$.

H-2.5.5 PTA Spiked Solution

In three 25 ml beaker, weigh 0.500 0 \pm 0.001 g of PTA and to them add 3 ml of ammonium hydroxide solution and 7 ml water, to completely dissolve PTA. Transfer these solutions accurately to three 250 ml volumetric flasks. In the above-mentioned flasks add 0.00, 1.00 and 2.00 ml (calibration point can be increased as per requirement) calibration standards of *p*-TA and 4-CBA and dilute to the mark with water. The concentrations of *p*-TA and 4-CBA added to these PTA are calculated as mentioned below:

In case of three standards (0.00, 1.00, and 2.00 ml) 4-CBA, ppm:

$$0.0, 20.0 \times K \text{ and } 40.0 \times K$$

In case of five standards (0.00, 0.50, 1.00, 1.50, and 2.00 ml)

4-CBA, ppm:

$$0.0, 10.0 \times K, 20.0 \times K, 30.0 \times K \text{ and } 40.0 \times K$$

where

$$K = \text{weight of 4-CBA from H-2.5.3}/0.0250 \text{ g.}$$

In case of three standards (0.00, 1.00 and 2.00 ml) *p*-TA, ppm:

$$0.0, 160.0 \times J \text{ and } 320.0 \times J$$

In case of five standards (0.00, 0.50, 1.00, 1.50, and 2.00 ml)

p-TA, ppm:

0.0, 80.0 x J, 160.0 x J, 240.0 x J and 320.0 x J

where

J = weight of *p*-TA from H-2.5.4/ 0.020 0 g.

H-2.5.6 Procedure

Analyze the series of PTA spiked solutions according to the procedure given at H-2.7 and record the value of peak area of *p*-TA and 4-CBA. Each sample should be run repeatedly to obtain the average peak area.

H-2.5.7 Calculation

Plot a calibration curve of the spiked concentration *v/s* average peak area. The linear calibration curve with a correlation coefficient (r^2) greater than or equal to 0.995 is derived; if not, the whole procedure is to be repeated. To interpret the calibration, a computer or data system may also be used (*see* Fig 1).

The linear equation is as follows:

$$A = a + bC \quad \text{————— (i)}$$

where

C = spiked concentration of *p*-TA or 4-CBA in the PTA sample, ppm (w/w) (H-2.5.5);

A = average peak area value of *p*-TA or 4-CBA;

b = slope; and

a = intercept

The concentration of *p*-TA and 4-CBA in this PTA sample is calculated by the following equation:

$$C_0 = \frac{a}{b} \quad \text{————— (ii)}$$

where

C_0 = concentration of *p*-TA or 4-CBA in PTA sample, ppm (w/w);

b = slope obtained from (i); and

a = intercept obtained from (i)

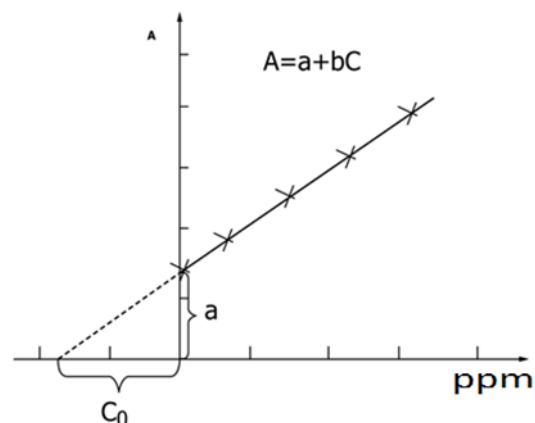

FIG. 1 STANDARD ADDITION METHOD FOR CALIBRATION OF *p*-TA OR 4-CBA IN PTA

H-2.6 Preparation of Apparatus

Set up the pump, sample injection system, column, oven, detector, and chromatography data system as mentioned in manufacturers manual. Adjust the instrument to the conditions given in Table 2. Equilibrium is indicated by a stable horizontal baseline and sufficient time is given to achieve it.

NOTES

1 Equilibration time of 4 to 6 h may be required for new column.

2 By carefully varying the aqueous-organic ratio and flow rate, separation of peaks of 4-CBA and PTA can be optimized.

3 Adding a certain amount of trifluoroacetic acid (TFA) in acetonitrile water solution as a mobile phase can improve separation between 4-CBA and PTA.

4 For improving chromatograph, a gradient mobile phase can also be used.

H-2.7 Calibration

In a 25 ml beaker, weigh around 0.5000 to the accuracy of 0.0001 g of PTA standard, add 3 ml ammonium hydroxide solution, and 7 ml water to completely dissolve PTA. Transfer the solution carefully to a 250 ml volumetric flask and dilute to the mark with water. For analysis, inject 20 l of the calibration standard solution into the chromatograph. With the data system, record the chromatogram and peak area values for *p*-TA and 4-CBA.

NOTES

1 To check the stability of chromatograph system, a calibration standard (quality control check) should be run after every ten samples.

2 Depending on the signal to noise ratio, the sample amount could vary up to 5.0 g.

H-2.8 Procedure

Weigh around 0.500 0 to the accuracy of 0.000 1 g of PTA standard and further follow steps as given in H-2.7. Record peak area values of *p*-TA and 4-CBA respectively. Rinse the column with mobile phase after each analysis until the baseline is stable for the next run. The representative chromatograms of a PTA sample is shown in Fig 2.

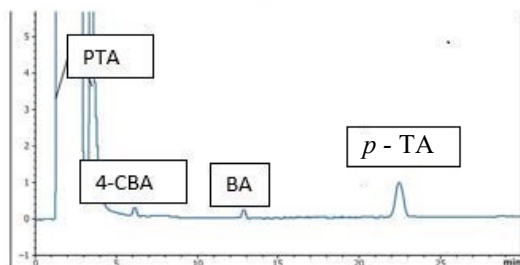

FIG. 2 TYPICAL CHROMATOGRAM OF A PTA SAMPLE (REVERSE PHASE HPLC)

H-2.9 Calculation

Concentration of *p*-TA/4-CBA in ppm (w/w) =

$$\frac{M \times A \times C_s}{m \times A_s}$$

H-2.11 Precision and Bias

Analyte	Average, ppm (w/w)	Repeatability limit, <i>r</i>	Reproducibility limit, <i>R</i>
<i>p</i> -TA	127.00	1.91	6.46
4-CBA	11.39	0.85	1.84

NOTE — Alternatively UHPLC may be used for determination of 4-carboxybenzaldehyde (4-CBA) and *p*-toluic acid (*p*-TA) content.

H-3 METHOD B DETERMINATION OF *p*-TOLUIC ACID (*p*-TA) IN PURE TEREPHTHALIC ACID BY GAS CHROMATOGRAPHIC METHOD

H-3.1 General

This method is used for the determination of *p*-toluic acid (*p*-TA) in terephthalic acid in the range of 0-200 ppm.

H-3.2 Summary of the Method

where

- X* = concentration in ppm (w/w) of *p*-TA or 4-CBA in PTA sample;
- A* = peak area of *p*-TA or 4-CBA in PTA sample;
- m* = weight of the PTA sample, g;
- A_s* = average peak area of *p*-TA or 4-CBA in PTA standard;
- C_s* = concentration in ppm (w/w) of *p*-TA or 4-CBA in PTA standard; and
- M* = weight of the PTA standard, g.

H-2.10 Report

H-2.10.1 Report *p*-TA and 4-CBA concentration in the PTA sample nearest to 1.0 ppm (w/w).

H-2.10.2 Report the following information in the report:

- The complete identification of the sample tested;
- Any deviation from the prescribed process (for example, detailed description of column and operating conditions);
- Results of the test; and
- Any unusual circumstances discovered throughout the test.

The sample is dissolved in tetramethylammonium hydroxide solution and injected into an injector (pyrolysis unit). The resulting esters are then separated by gas chromatography using a heart cut system for estimation of the *p*-toluic acid content.

H-3.3 Principle

Pure terephthalic acid dissolved in tetramethylammonium hydroxide (TMA) is injected in pyrolysis block maintained (400 ± 5)°C. All the acids get converted into respective esters. Thus, *p*-toluic acid gets converted to methyl-*p*-toluate (MPT).

This methyl-*p*-toluate (MPT) is determined by separation technique on GC column using heart cut system.

H-3.4 Apparatus

H-3.4.1 Gas Chromatography

Any suitable gas chromatography with flame ionization detector equipped with heart-cutting system with a pyrolysis unit heated to 400°C. Integrator A suitable computing integrator and syringe microliter syringe of 10 µl size.

H-3.4.1.1 Chromatographic Column

- a) Pre-column — 3.18 mm Stainless steel 1 m column packed with 10 percent SP-1000 on 80-100 mesh AW Chromosorb W or equivalent
- b) Main-column — 3.18 mm Stainless steel 2 m column packed with 10 percent SP-1000 on 80-100 mesh AW Chromosorb W or equivalent

H-3.4.1.2 Column Conditioning

Condition the column before use for 12 h having nitrogen carrier flow of 30 ml/min.

H-3.5 Reagents

H-3.5.1 Instrument air, pure with very low hydrocarbons.

H-3.5.2 Hydrogen, commercial grade.

H-3.5.3 Nitrogen, commercial grade.

H-3.5.4 *p*-toluic acid (*p*-TA), 99.0 percent purity.

H-3.5.5 Tetramethylammonium hydroxide, 25 percent aqueous solution.

H-3.5.6 Terephthalic acid (TA), pure containing known amount of *p*-toluic acid (*p*-TA).

NOTES

1 Tetramethylammonium hydroxide is corrosive and causes burns to the skin.

2 The gas chromatographic conditions are suggestive. However, any GC having different columns (packed/capillary having different length/diameter/film thickness) and different carrier gas (He, H₂ or N₂), with different calibration technique (internal standard, external standard, area normalization) may be used provided standardization/ calibrations are done after setting up chromatographic conditions for required resolution.

H-3.6 Method for Establishing GC for *p*-TA Analysis

H-3.6.1 Set the condition as follows:

Injector pyrolysis block	:	400 °C
Detector temperature	:	200 °C
Column/oven (isothermal) temperature	:	180 °C
Carrier gas	:	Nitrogen

H-3.6.2 Energize the solenoid valve manually via push buttons on flow switching unit (FSU) and set the primary nitrogen regulator (stream 1) to the 1.9 kg/cm² (27 psig). At this time secondary nitrogen regulator must be turned off and heart cut needle valve (in FSU) should be fully open. Allow the system to attain equilibrium that may take about 15-20 min and note the natural mid-point pressure (secondary nitrogen/stream 2 pressure gauge). Measure the carrier gas flow rate at FID vent (Air/H₂ off). It should be 5 ml in 14.0 ± 0.1 s by bubble flow meter. If it is not so, adjust the flow using PF (premium regulator 1). De-energize the solenoid valve manually by push bottom on FSU. Now the mid-point pressure will decrease gradually via the heart cut vent. Using secondary nitrogen pressure regulator (PR2), increase the mid-point pressure to 3.447 kPa (0.5 psig) greater than the noted natural mid-point pressure. With the solenoid valve energized, measure the flow rate at the FID vent (Air/H₂ off). Note this value. De-energize the solenoid valve and adjust the heart cut needle valve to give a flow rate equal to measured at FID vent that is 5 ml in 12.0 min.

NOTE — To achieve the above-mentioned rate, slight variation in pressure may be necessary, if pressure required to check for column leaks, septum leak, etc is higher.

H-3.6.3 Set the FID air and hydrogen to the flow rates below:

$$\text{Hydrogen pressure} = 0.75 \text{ kg/cm}^2 \text{ (10.5 psig)} = 31.3 \text{ ml/min} + 5.0$$

$$\text{Air pressure} = 0.45 \text{ kg/cm}^2 \text{ (6.5 psig)} = 258.6 \text{ ml/min} + 10.0$$

H-3.6.4 Light the flame and allow the system to stabilize overnight.

H-3.7 Calibration

H-3.7.1 Three-point Calibration

A certified terephthalic acid (TA) calibration standard with known amounts of *p*-TA is to be used for calibration blend preparation. In case of non-

availability of certified terephthalic acid (TA) calibration standard, the concentrations of *p*-TA in a TA sample may be prepared by using **H-3.7.2** and GC instrument may be calibrated.

H-3.7.2 Preparation of Standards

H-3.7.2.1 Solution A

Weigh accurately 0.50 g of *p*-toluic acid, dissolve in methanol and dilute to 100 ml in a volumetric flask, with methanol. Take 1.0 ml of this solution and dilute to 100 ml with distilled water.

Vial	1	2	3	4	5
TA, g	1.00	1.00	1.00	1.00	1.00
<i>p</i> -TA solution A, ml	NIL	1.0	NIL	3.0	NIL
<i>p</i> -TA solution B, ml	NIL	NIL	2.0	NIL	4.0
H ₂ O, ml	5.0	4.0	3.0	2.0	1.0
Tetramethylammonium hydroxide (TMA), ml	5.0	5.0	5.0	5.0	5.0
<i>p</i> -TA added, ppm	0	50	100	150	200

H-3.7.2.4 Plot a calibration graph of peak area (corrected for blank v/s *p*-TA added for preparing the standards.

H-3.7.2.5 Calculate the response factor for each standard using following formula:

Response factor

$$= \frac{\text{Peak area}}{p\text{-TA ppm of standard solution}}$$

H-3.8 Preparation of Sample

Weigh 1.0 ± 0.1 g *p*-toluic acid (*p*-TA) sample in paper boat. Transfer the sample in vial, add 100 ml 1:1 tetramethylammonium hydroxide (TMA) water solution and dissolve the sample. Inject 5.0 μ l of sample solution in GC using 10 μ l syringe.

H-3.9 Calculation

After getting the correct retention time of peak of interest and calculated response factor of standard, feed it in computing integrator. At the end of run,

H-3.7.2.2 Solution B

Weigh accurately 0.25 g of *p*-toluic acid, dissolve in methanol and dilute to 50 ml in a volumetric flask, with methanol. Take 1.0 ml of this solution and dilute to 100 ml with distilled water.

H-3.7.2.3 Take 5 vials numbered 1-5 and weigh 1.00 g of TA of low *p*-TA content (less than 100 ppm) into each vial. Then add solutions A and B, water and tetramethylammonium hydroxide (25 percent) as detailed in the table below:

integrator will automatically give the ppm of *p*-toluic acid present in sample or we can calculate as:

p-TA Acid, ppm

$$= \frac{\text{Peak area of sample} \times \text{standard concentration}}{\text{Peak area of standard}}$$

H-4 METHOD C DETERMINATION OF 4-CARBOXYBENZALDEHYDE IN PURE TEREPHTHALIC ACID USING POLORAGRAPHIC ANALYZER

H-4.1 General

This method is for the determination of 4-carboxy benzaldehyde (4-CBA) in pure terephthalic acid (PTA) in the range 0 to 50 ppm.

H-4.2 Summary of the Method

The sample is dissolved in 1 M potassium hydroxide solution and 0.01 percent polyethylene glycol 6 000 (PEG 6 000) is added. After deoxygenating with nitrogen, the differential pulse polarogram is

recorded and the height of the carbonyl reduction wave at -1.32 V (relative to a saturated calomel electrode) is measured. This peak height is proportional to the concentration of 4-CBA in the sample and from a calibration graph, constructed using standard solutions, the concentrations of 4-CBA is determined.

H-4.3 Principle

Polarographic technique is used for those components in solution that can be electrochemically oxidized or reduced. In this potential (voltage) is applied to sample via a conductive electrode that is dropping mercury electrode which is also called as working electrode. Potential is scanned over region of interest, much as the wavelength of light is scanned in spectroscopic measurements. When component is reduced/oxidized at particular potential current will flow at working electrode and the potential at which the current is one half the diffusion value is half wave potential $E^{1/2}$. This $E^{1/2}$ is characteristic of particular substance undergoing reaction and is useful in identifying the solution constituents. Table of $E^{1/2}$ values for various organic and inorganic species is available in reference books.

For determination of 4-CBA, differential pulse polarographic technique is used in which voltage is applied to the cell in pulses. Current produced after reduction of 4-CBA is measured twice for each drop, first just before pulse is applied and second just before pulse ends. The difference in two readings is signal which is fed to X-Y flatbed recorder and peak proportional to concentration of 4-CBA is recorded.

H-4.4 Interference

Dissolved oxygen is expelled from the test solution with inert gas such as argon or nitrogen or otherwise polarogram of dissolve oxygen will interfere with the sample. Polyethylene glycol 16 000 is added in test solution to suppress the polarographic maximum which normally interferes in peak of interest.

H-4.5 Apparatus

A suitable polarographic analyzer fitted with dropping mercury electrode and XY flatbed recorder.

H-4.6 Reagents

H-4.6.1 Potassium Hydroxide Solution, 1 M.

Dissolve 330 g of potassium hydroxide, AR grade in water and make up to 5 l.

H-4.6.2 Pure Terephthalic Acid (TA).

Containing less than 5 ppm 4-CBA is suitable.

H-4.6.3 Polyethylene Glycol 6 000 (PEG 6 000) solution, 1 percent (m/v)

Dissolve 1.0 g of PEG 6 000, GR grade in water and make up to 100 ml in standard flask shake well to ensure complete solution.

H-4.6.4 4-Carboxybenzaldehyde, AR Grade, 99 percent purity.

H-4.7 Calibration Standard

H-4.7.1 Weigh 0.100 0 g of pure 4-CBA into 50 ml beaker. Add approximately 30 ml of 1 M potassium hydroxide and stir to dissolve. Quantitatively transfer this solution to a 100 ml volumetric flask; and dilute to mark, with 1 M potassium hydroxide. Call this solution 'A'.

1 ml solution 'A' = 1 mg 4-CBA.

H-4.7.2 Pipette 10 ml of solution A into 100 ml volumetric flask and dilute to the mark with 1 M potassium hydroxide. Call this solution 'B'.

1 ml solution B = 100 μ g 4-CBA.

NOTES

1 Solution A and B are not stable and should be made as and when required.

2 If 4-CBA is dissolved in warm potassium hydroxide solution, yellow colour can occur, indicative of chemical reaction. If this occurs, 4-CBA solution should be discarded and cold potassium hydroxide solution should be used before making standard.

3 Argon/Nitrogen, approximately 10.342 kPa (1.5 psi) for 16 min to ensure absence of oxygen peak.

4 Mercury, polarographic grade or AR grade.

CAUTION — As mercury is very poisonous and its vapours are harmful, mercury should be handled very carefully. If any spillage occurs, mercury should be removed immediately using vacuum.

H-4.8 Calibration

H-4.8.1 Three-point Calibration

Into six 100 ml volumetric flasks weigh 5.00 g of pure terephthalic acid (TA). Pipette 1 ml of 1 percent (m/v) PEG 6 000 solution into each flask and add approximately 75 ml of 1 M potassium hydroxide. Stopper the flasks and shake vigorously, to dissolve terephthalic acid (TA). To series of 100 ml flasks add from pipette 0, 0.5, 1.0, 1.5, 2.0, 2.5 ml of solution B respectively. Make up to the mark with 1 M potassium hydroxide. Shake well to mix and then record the polarogram for each standard as described

in procedure. Plot a calibration curve of μg 4-CBA v/s peak height (corrected for blank). Calculate the mean factor as $F = 1/\text{Slope}$.

H-4.9 Procedure

H-4.9.1 Conditions

The following operating conditions for polarographic analyzer are given for guidance only.

H-4.9.1.1 Polarographic Analyzer

Initial potential	:	-0.90 V
Final potential	:	-1.40 V
Scan rate	:	-2 mv/s
Mode	:	Differential pulse
Pulse height	:	50 mV
Current range	:	10 μA
Equilibrium time	:	15 s
Drop time	:	1 s
Replication cycles	:	1
Scan rate multiplier	:	X_1
Filter (DC only)	:	OFF

H-4.9.1.2 Dropping Mercury Electrode

Drop size	:	large (out of large, medium, small)
Mode	:	DME/HMDE (out of SMDE, DME, HMDE)

H-4.9.1.3 XY Flat Bed Recorder

Var/cal 'X'	:	Cal 0.1 mv/cm
Var/cal 'Y'	:	Cal 01 mv/cm

H-4.9.2 Sample Preparation

Transfer quantitatively 5.0 ± 0.01 g of pure terephthalic acid into 100 ml volumetric flask. Pipette 1 ml of 1 percent (m/v) PEG 6 000 solution to the flask. Add 75 ml of 1 M potassium hydroxide and stopper the flask. Shake vigorously till all terephthalic acid (TA) is dissolved. Make up to the mark with 1 M potassium hydroxide and mix well. Pour approximately 12 ml of this solution into

olarographic cell and deoxygenate with nitrogen for 16 min with slow purging. Check all the operating conditions as given. Check that dropping mercury electrode, calomel electrode and platinum electrode are well immersed in the solution. Start the polarograph by pressing 'RUN' and start the recorder and lower the recorder pen. On completion of polarogram, switch 'OFF' the recorder. Remove the cell. Clean the cell, capillary and electrodes with distill water and refill the cell with distilled water and put it back. Measure the peak height in mm. Start the recorder and lower the recorder pen.

H-4.10 Calculation

$$4\text{-CBA, ppm } (m/m) = \frac{\text{Height (mm)} \times F}{\text{Mass of sample}}$$

where

F = factor from calibration curve.

NOTE — In place of polyethylene glycol other buffers as per OEM may also be used.

H-5 DETERMINATION OF P-TOLUIC ACID (*p*-TA) AND 4-CARBOXYBENZALDEHYDE (4-CBA) IN PURIFIED TEREPHTHALIC ACID (PTA) BY NORMAL VOLTAGE MODE CAPILLARY ELECTROPHORESIS

H-5.1 General

This method is used for the determination of *p*-toluic acid (*p*-TA) and 4-carboxybenzaldehyde (4-CBA) in purified terephthalic acid (PTA) by capillary electrophoresis (CE) with normal voltage mode and UV detection. It is applicable for *p*-toluic acid (*p*-TA) in the range of 10 to 400 ppm (w/w) and for 4-carboxybenzaldehyde (4-CBA) in the range of 5 to 400 ppm (w/w).

H-5.2 Summary of Test Method

The sample is dissolved in ammonium hydroxide solution. *p*-toluic acid, 4-carboxybenzaldehyde and terephthalic acid gets dissociate and become homologous ions under basic conditions. Using hydrodynamic sampling, a fixed amount of this solution is introduced into the capillary. A voltage is applied to the capillary to separate the impurities, *p*-TA and 4-CBA from PTA. External standard calibration is used for quantification.

H-5.3 Apparatus

H-5.3.1 Capillary Electrophoresis System (see Fig. 3 for components)

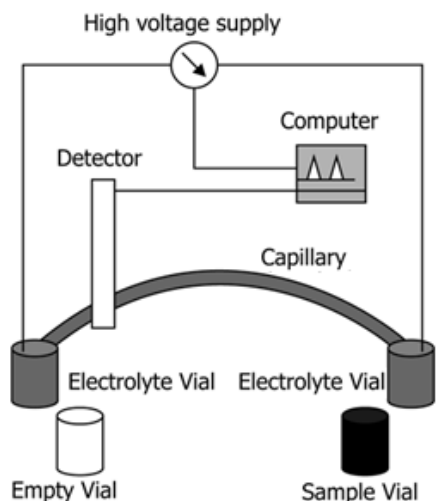

FIG. 3 INSTRUMENTAL SETUP

H-5.3.1.1 High voltage power supply, which can generate 0-30 kV voltage and has constant voltage working ability.

H-5.3.1.2 Covered sample carousel, to prevent environmental contamination of samples and electrolytes during a multi sample batch analysis.

H-5.3.1.3 Sample introduction mechanism, capable of hydrodynamic sampling technique.

H-5.3.1.4 Capillary purge mechanism, to purge the capillary with fresh electrolyte to eliminate any interference from the previous sample matrix and clean the capillary with sodium hydroxide solution and water, after each analysis.

H-5.3.1.5 UV detector, 200 nm.

H-5.3.2 Fused Silica Capillary Column.

With 50 to 100 μm (internal diameter) x 375 μm (outer diameter) x 60 cm (length), with polymer coating for flexibility, and with an uncoated part which act as a cell window for UV detection.

H-5.3.3 Constant Temperature compartment, keep the sample, capillary and electrolyte at a constant temperature.

H-5.3.4 Data System

A computer system that can collect data at a minimum speed of 20 points/s. The migration time is expressed in min to three decimal places.

H-5.3.5 Sample Filter

A disposable syringe filter made of cellulose acetate with a pore size of 0.22 to 0.45 μm . It is chemically inert to aqueous solutions and is recommended for removing particulate matter in sample solutions

H-5.3.6 pH Meter, composed of glass calomel double electrodes.

H-5.4 Reagents

Unless otherwise specified, AR grade chemicals shall be used.

H-5.4.1 1-Heptanesulfonic Acid Sodium Salt Monohydrate or Sodium 1-heptanesulfonate.

H-5.4.2 Sodium Phosphate Tribasic Dodecahydrate or trisodium phosphate (see IS 573).

H-5.4.3 Sodium Hydroxide.

H-5.4.4 Ammonium Hydroxide Solution, 25 percent (w/w).

H-5.4.5 PTA Standard for Calibration

A certified PTA calibration standard with known amounts of *p*-TA and 4-CBA is required. In case of non-availability of PTA calibrated standard, the concentrations of *p*-TA and 4-CBA in a PTA sample can be determined by calibration procedure mentioned at **H-5.5**. The calibrated PTA sample may be used as a PTA calibration standard.

H-5.4.6 Sodium Hydroxide Solution (0.5 mol/l sodium hydroxide).

Dissolve approximately 20 g of sodium hydroxide in a 1 l plastic volumetric flask and dilute to 1 l with water.

H-5.4.7 Ammonium Hydroxide Solution.

Dissolve approximately 50 ml of 25 percent ammonium hydroxide and dilute to 500 ml with water in 500 ml volumetric flask.

H-5.4.8 Electrolyte Solution: Working in normal voltage mode (50 mM 1-heptanesulfonic acid sodium salt monohydrate and 2.5 mM sodium phosphate tribasic dodecahydrate)

Dissolve approximately 11.012 g 1-heptanesulfonic acid sodium salt monohydrate and 0.9503 g sodium phosphate tribasic dodecahydrate in 1 000 ml volumetric flask and dilute to 1 000 ml with water. The solution is to be filtered and degassed before use.

H-5.5 Procedure for Calibration of PTA sample by individual components

H-5.5.1 To determine the concentrations of *p*-TA and 4-CBA, a PTA sample with granularity of 80 to 160 μm , containing 4-CBA and *p*-TA at concentrations of 10 to 25 ppm and 100 to 200 ppm, respectively, are to be analysed. This PTA sample

with calibrated concentrations of *p*-TA and 4-CBA can be used as the PTA standard for sample analysis.

H-5.5.2 Reagents

H-5.5.2.1 *p*-Toluic acid (*p*-TA), purity 98.0 percent, minimum.

H-5.5.2.2 4-Carboxybenzaldehyde (4-CBA), purity 98.0 percent, minimum.

H-5.5.3 4-CBA (10 µg/ml) Calibration Standard

Weigh about 0.0250 g (to nearest 0.000 1 g) of 4-CBA in a 25 ml beaker, add water and a few drops of ammonium hydroxide solution, and stir until 4-CBA is completely dissolved. Then accurately transfer the resulting solution to a 50 ml volumetric flask and dilute to the mark with water to make the concentration 500 ppm. Then dilute with water 50 times to 10 ppm.

H-5.5.4 *p*-TA (80 µg/ml) Calibration Standard.

Weight about 0.020 0 g (to nearest 0.000 1 g) of *p*-TA and prepare 400 ppm *p*-TA standard solution as prepared in H-5.5.3. Then dilute with water to 80 ppm.

H-5.5.5 PTA Spiked Solution

Add 0.5000 ± 0.001 g of PTA, 7 ml of ammonium hydroxide solution in five 25 ml beakers, heat and stir until PTA is completely dissolved. Transfer these solutions accurately to five 25 ml volumetric flasks. In the above-mentioned flasks add 0.00, 0.50, 1.00, 1.50 and 2.00 ml calibration standards of *p*-TA and 4-CBA and dilute to the mark with water. The concentrations of *p*-TA and 4-CBA added to these PTA are calculated as mentioned below:

NOTE — To dissolve PTA in ammonium hydroxide solution magnetic stirrer or ultrasonic bath can also be used.

4-CBA/BA, ppm:

0.0, 10.0 x K, 20.0 x K, 30.0 x K and 40.0 x K

where

K = weight of 4-CBA from H-5.5.4/ 0.0250 g.
p-TA, ppm:

0.0, 80.0 x J, 160.0 x J, 240.0 x J and 320.0 x J

where

J = weight of *p*-TA from H-5.5.5/0.020 0 g.

H-5.5.6 Procedure

Analyse the series of PTA spiked solutions according to the procedure given at H-5.7 and record the value of peak area of *p*-TA and 4-CBA. Each sample should be run repeatedly to obtain the average peak area.

H-5.5.7 Calculation

Plot a calibration curve of the spiked concentration v/s average peak area. The linear calibration curve with a correlation coefficient (*r*, known as Pearson's correlation coefficient) greater than or equal to 0.995 is derived; if not, the whole procedure is to be repeated. To interpret the calibration, a computer or data system may also be used (see Fig 4).

The linear equation is as follows:

$$A = a + bC \text{ ————— (i)}$$

where

C = spiked concentration of *p*-TA or 4-CBA in the PTA sample, ppm (w/w) [H-5.5.5];

A = average peak area value of *p*-TA or 4-CBA;

b = slope; and

a = intercept

The concentration of *p*-TA and 4-CBA in this PTA sample is calculated by the following equation:

$$C_0 = \frac{a}{b} \text{ ————— (ii)}$$

where

*C*₀ = concentration of *p*-TA or 4-CBA in PTA sample, ppm (w/w);

b = slope obtained from (i); and

a = intercept obtained from (i)

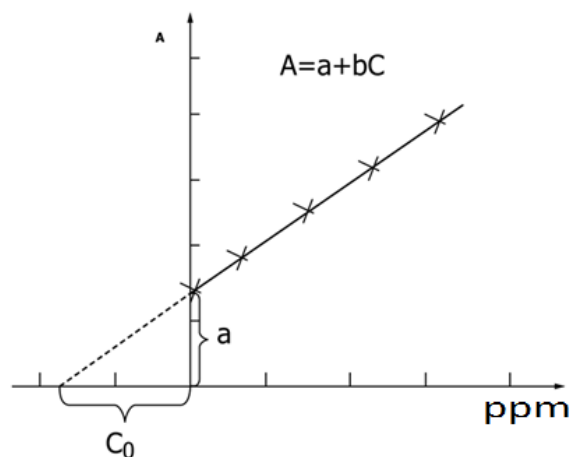

FIG. 4 STANDARD ADDITION METHOD FOR CALIBRATION OF *P*-TA OR 4-CBA IN PTA

H-5.6 Preparation of apparatus

H-5.6.1 Set up capillary electrophoresis system and data system as mentioned in manufacturer's manual. Adjust the instrument to the conditions given in Table 3.

Table 3 Suggested Operating Conditions *
(Clause H-5.6.1)

Normal Voltage Mode	
Electrolyte	50 mM 1-heptanesulphonic acid sodium salt monohydrate and 2.5 mM sodium phosphate tribasic dodecahydrate <i>or</i> 50 mM sodium 1-heptanesulfonate and 10 mM trisodium phosphate
Applied voltage	+ (15-25) kV
Injection technique	Hydrodynamic sampling, (3.3-5) kPa x (15-50) s
Capillary purge program	Water: 10 min; electrolyte: 6 min
Capillary	Inner diameter (50-100) μm ; length (40-70) cm
Detector	UV, 200 nm or equivalent
Capillary Cassette temperature	(20-30) $^{\circ}\text{C}$

* Instrumental conditions may vary to obtain optimum peak size and peak area based on manufacturer's instructions.

H-5.6.2 A constant temperature is to be maintained in capillary electrophoresis system. The electrolyte reservoir is filled with fresh electrolyte working solution and is allowed to stand for 10 min for obtaining thermal equilibrium. A new capillary prior to use is to be conditioned with 0.5 mol/l sodium hydroxide solution for 5 min, followed by water for 5 min. Then the capillary is purged with electrolyte for 3 min. Current is tested by applying 15 kV voltage. If there is no current, the capillary may have a bubble, a blockage, or both. Retry after degassing the electrolyte working solution. Replace the capillary if there is still no current. Set the UV detector to a detection wavelength of 200 nm, or equivalent and the absorbance value to 0.000. UV offset is less than 0.1 AU. For normal voltage mode, programme the CE system with a constant voltage of + (15-25) kV. Set up the CE system for a hydrodynamic sampling. Different sampling times are acceptable as long as the samples and standards are analyzed in the same way. Allow the CE system to run for 10 min and 6 min. Between each analysis,

purge with water and electrolyte in series. Set the data system's acquisition rate to at least 20 points/s. Program the data system such that analyte peaks are identified based on migration time, and peak area is used to quantify analyte peak response.

H-5.7 Procedure

H-5.7.1 Calibration

In a 100 ml volumetric flask, weigh 2.0 g of PTA standard (to the nearest 0.000 1 g), add 4 ml ammonium hydroxide solution (**H-5.4.7**) and 50 ml distilled water and stir until PTA is completely dissolved. Then dilute it to the mark with water. Inject a small amount of the calibration standard solution into the CE for analysis once steady operating conditions are achieved. Using the data system, record electropherograms and peak area values for *p*-TA and 4-CBA. Calculate the average peak area after analysing the calibration standard three times.

NOTE — To dissolve PTA in ammonium hydroxide solution magnetic stirrer or ultrasonic bath can also be used.

H-5.7.2 Analysis of samples

Weigh about 2.0 to 4.0 g PTA sample (to the nearest 0.000 1 g) and repeat other procedures given at H-

5.7.1. Record the peak area values of *p*-TA and 4-CBA. Run the sample. Rinse the capillary with water for 10 min and then with electrolyte for 6 min, after each assay. Electropherogram of a PTA sample is given in Fig. 5.

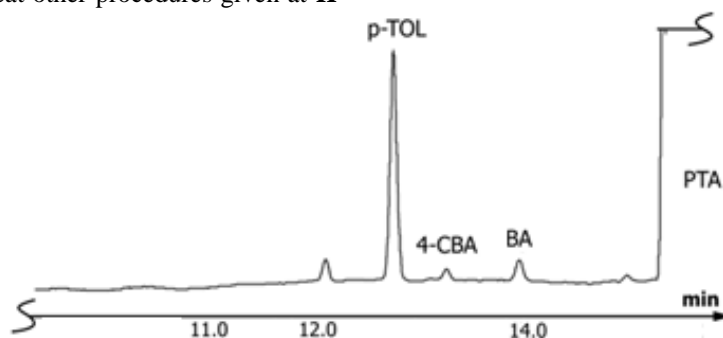

FIG. 5 ELECTROPHEROGRAM OF A PTA SAMPLE IN THE NORMAL VOLTAGE MODE

NOTE — It is recommended that a calibration standard be run after every ten samples to check the stability of the chromatograph system.

H-5.8 Calculation

Concentration of *p*-TA/4-CBA, ppm (*w/w*) (*X*) =

$$\frac{M \times A \times C_s}{m \times A_s}$$

where

- X* = concentration in ppm (*w/w*) of *p*-TA or 4-CBA in PTA sample;
- A* = peak area of *p*-TA or 4-CBA in PTA sample;
- m* = weight in g of the PTA sample;
- A_s* = average peak area of *p*-TA or 4-CBA in PTA standard;
- C_s* = concentration in ppm (*w/w*) of *p*-TA or 4-CBA in PTA standard; and
- M* = weight of the PTA standard, g.

H-5.9 Report

H-5.9.1 Report *p*-TA and 4-CBA concentration in the PTA sample nearest to 1.0 ppm (*w/w*, *mg/kg*).

H-5.9.2 Report the following information in the report:

- The complete identification of the sample tested;
- Any deviation from the prescribed process (for example, detailed description of column and operating conditions);
- Results of the test; and
- Any unusual circumstances discovered throughout the test.

H-5.10 Precision

Analyte	Average, ppm (<i>w/w</i>)	RSD percent
<i>p</i> -TA	209.8	0.36
4-CBA	31.3	1.00
BA	33.9	0.59

NOTE — Precision is derived based on the study conducted by Committee members.

ANNEX J
(Clauses E-2.1 and F-2.1)

**LIST OF INDIAN STANDARDS FOR DETERMINATION OF IMPURITIES USING ATOMIC
ABSORPTION SPECTROPHOTOMETRY**

<i>IS No.</i>	<i>Title</i>	<i>IS No.</i>	<i>Title</i>
10614 : 1983	Method for atomic absorption spectrophotometric determination of sodium and potassium	12122 : 1987	Method for determination of nickel by atomic absorption spectrophotometry
12046 : 1987	Method for determination of manganese by atomic absorption spectrophotometry	12491 : 1988	Method for determination of magnesium by atomic absorption spectrophotometry
12074 : 1987	Method for determination of lead by atomic absorption spectrophotometry	13319 : 1992	Determination of chromium by atomic absorption spectrophotometry —test method
		13320 : 1992	Determination of iron by atomic absorption spectrophotometry — Test method

ANNEX K
(Clause G-6.1)
(Informative Annex)

K-1 PRELIMINARY ICP INSTRUMENT CHECK

K-1.1 Check the following check points of the instrument ICP–OES before use

- | | |
|---|--|
| <ul style="list-style-type: none"> a) Ensure Argon cylinder pressure should be more than 40 kg/sq cm. b) Ensure that the radiofrequency coil (RF) coil is clean. Wipe out condensed water droplets, if any. c) Check the torch, aerosol injector tube for deposits. Clean, if required. d) Check that the nebulizer end cap is tightly secured to the spray chamber and the sample tubing is properly attached to it. | <ul style="list-style-type: none"> e) Check that the drain fitting is secured on the spray chamber drain. Loose fitting drain can cause pressure leaks and plasma instability. f) Check that the peristaltic pump tubing is in good condition, has no flat spots and is correctly installed around the pump head. g) Check that the spray chamber drain is properly set up on the pump so that waste is pumped out of the spray chamber. h) Check the spray chamber drain and the drain underneath the sample shelf lead to the drain bottle. Empty the drain - bottle if necessary. Dispose off waste properly. |
|---|--|

ANNEX L
(Foreword)

COMMITTEE COMPOSITION

Organic Chemicals, Alcohols and Allied Products Sectional Committee, PCD 09

<i>Organization</i>	<i>Representative(s)</i>
Chemical Engineering and Process Development Division, NCL, Pune	DR C. V. RODE (<i>Chairperson</i>)
Alkyl Amines Chemicals Limited, Mumbai	SHRI S. V. NIKUMBHE SHRI SAMEER KATDARE (<i>Alternate</i>)
All India Alcohol-Based Industries Development Association (AABIDA), Mumbai	SHRI K. L. RAPHAEL SHRI KIRTI GAJJAR (<i>Alternate</i>)
All India Distillers Association (AIDA), New Delhi	SHRI V. N. RAINA
BASF India Limited, Mumbai	SHRI KIRAN BHAT SHRI HEMAL (<i>Alternate</i>)
CSIR- Central Drug Research Institute (CDRI), Lucknow	DR SANJEEV KANOJIYA
Chemical And Petrochemicals Manufacturers Association (CPMA), New Delhi	SHRI MAHINDER SINGH
Deepak Fertilizer, New Delhi	DR L. B. YADAWA SHRI. SURESH AMLE (<i>Alternate</i>)
Deepak Phenolics Limited, Vadodara	SHRI DHARMESH SIDDHAPURIA SHRI SANDIP KUMAR PANDYA (<i>Alternate</i>)
Department of Chemicals and Petrochemicals, Ministry of Chemicals and Fertilizers, New Delhi	SHRI O. P. SHARMA SHRI VARUN SINGH POONIA (<i>Alternate</i>)
Dow Chemical International Private Limited, Mumbai	SHRI V. MOHANDOSS SHRI GOVIND GUPTA (<i>Alternate</i>)
Godavari Biorefineries, Mumbai	SHRI SHANUL LAXMANRAO PAGAR SHRI APPASAHEB J. WANI (<i>Alternate</i>)
Gujarat Narmada Valley Fertilizers Company Limited, Ahmedabad	DR R. M. PATEL SHRI C. S. PATEL (<i>Alternate</i>)
Hindustan Organic Chemicals Limited (HOCL), Mumbai	SHRI DELEEP KUMAR. K SHRI V. MOHAN (<i>Alternate</i>)
India Glycols Limited, Uttarakhand	DR R. K. SHARMA SHRI ALOK SINGHAL (<i>Alternate</i>)
Indian Chemical Council (ICC), Mumbai	DR MRITUNJAY CHAUBEY SHRI J SEVAK (<i>Alternate</i>)

<i>Organization</i>	<i>Representative(s)</i>
Indian Oil Corporation Limited, Panipat	DR Y. S. JHALA
Jubilant Life Sciences Limited, Noida	SHRI HARI MOHAN LOHANI
Laxmi Organic Industries, Mumbai	SHRI J. P. SURYAVANSHI DR VIJAY S. MISHRA (<i>Alternate</i>)
National Chemical Laboratory (NCL), Pune	DR RAVINDAR KONTHAM DR UDAYA KIRAN MARELLI (<i>Alternate</i>)
National Test House (NTH) , Kolkata	SHRI DEBASHIS SAHA DR GOPAL KRISHAN (<i>Alternate</i>)
Reliance India Limited (RIL), Mumbai	SHRI SREERAMACHANDRAN KARTHA SHRI. VASANT WARKE (<i>Alternate</i>)
United Phosphorus Limited (UPL), Mumbai	SHRI M D VACHHANI
In Personal Capacity (<i>37 Nandanvan Society, Near GNFC Township, Narmadanagar, Bharuch – 392015</i>)	DR. MAYUR J. KAPADIA
BIS Director General	SHRIMATI MEENAL PASSI, SCIENTIST 'E'/ DIRECTOR AND HEAD (PERTROLEUM, COAL AND RELATED PRODUCTS DEPARTMENT) [REPRESENTING DIRECTOR GENERAL (<i>Ex-officio</i>)]

Member Secretary
MS ADITI CHOUDHARY
SCIENTIST 'B' /ASSISTANT DIRECTOR
(PERTROLEUM, COAL AND RELATED PRODUCTS DEPARTMENT), BIS

Bureau of Indian Standards

BIS is a statutory institution established under the *Bureau of Indian Standards Act, 2016* to promote harmonious development of the activities of standardization, marking and quality certification of goods and attending to connected matters in the country.

Copyright

BIS has the copyright of all its publications. No part of these publications may be reproduced in any form without the prior permission in writing of BIS. This does not preclude the free use, in the course of implementing the standard, of necessary details, such as symbols and sizes, type or grade designations. Enquiries relating to copyright be addressed to the Head (Publication & Sales), BIS.

Review of Indian Standards

Amendments are issued to standards as the need arises on the basis of comments. Standards are also reviewed periodically; a standard along with amendments is reaffirmed when such review indicates that no changes are needed; if the review indicates that changes are needed, it is taken up for revision. Users of Indian Standards should ascertain that they are in possession of the latest amendments or edition by referring to the website-www.bis.gov.in or www.standardsbis.in.

This Indian Standard has been developed from Doc No.: PCD 09 (18966).

Amendments Issued Since Publication

Amend No.	Date of Issue	Text Affected

BUREAU OF INDIAN STANDARDS

Headquarters:

Manak Bhavan, 9 Bahadur Shah Zafar Marg, New Delhi 110002

Telephones: 2323 0131, 2323 3375, 2323 9402

Website: www.bis.gov.in

Regional Offices:

	Telephones
Central : 601/A, Konnectus Tower -1, 6 th Floor, DMRC Building, Bhavbhuti Marg, New Delhi 110002	{ 2323 7617
Eastern : 8 th Floor, Plot No 7/7 & 7/8, CP Block, Sector V, Salt Lake, Kolkata, West Bengal 700091	{ 2367 0012 2320 9474
Northern : Plot No. 4-A, Sector 27-B, Madhya Marg, Chandigarh 160019	{ 265 9930
Southern : C.I.T. Campus, IV Cross Road, Taramani, Chennai 600113	{ 2254 1442 2254 1216
Western : Plot No. E-9, Road No.-8, MIDC, Andheri (East), Mumbai 400093	{ 2821 8093

Branches : AHMEDABAD. BENGALURU. BHOPAL. BHUBANESHWAR. CHANDIGARH. CHENNAI. COIMBATORE. DEHRADUN. DELHI. FARIDABAD. GHAZIABAD. GUWAHATI. HIMACHAL PRADESH. HUBLI. HYDERABAD. JAIPUR. JAMMU & KASHMIR. JAMSHEDPUR. KOCHI. KOLKATA. LUCKNOW. MADURAI. MUMBAI. NAGPUR. NOIDA. PANIPAT. PATNA. PUNE. RAIPUR. RAJKOT. SURAT. VISAKHAPATNAM.