टेलीस्कोपिक बॉल बेयरिंग दराज़ की
स्लाइड — विशिष्ट

Telescopic Ball Bearing Drawer Slide
— Specification

ICS 91.1.90

© BIS 2023



भारतीय मानक ब्यूरो
BUREAU OF INDIAN STANDARDS
मानक भवन, 9 बहादुर शाह ज़फर मार्ग, नई दिल्ली - 110002
MANAK BHAVAN, 9 BAHADUR SHAH ZAFAR MARG
NEW DELHI - 110002
www.bis.gov.in www.standardsbis.in

FOREWORD

This Indian Standard was adopted by the Bureau of Indian Standards, after the draft finalized by the Builders' Hardware Sectional committee, had been approved by the Civil Engineering Division Council.

Drawer slides had initially been in the form of profiles of inner and outer members, and have recently evolved to multi-member complex shape profiles made with a variety of materials. The telescopic ball bearing slides provide smooth functioning of drawers resulting in ease of function with the help of folding channels and ball fittings. This standard has been formulated to ensure the consistency, reliability and durability of telescopic ball bearing drawer slides. It covers the classification, materials, manufacture, testing, sampling and criteria for conformity, packing and marking of the telescopic ball bearing slides.

This standard contributes to the sustainable development goal 9 'industry, innovation, and infrastructure : Built resilient infrastructure, promote inclusive and sustainable industrialization and foster innovation'.

The composition of the Committee responsible for the formulation of this standard is listed in Annex B.

For the purpose of deciding whether a particular requirement of this standard is complied with, the final value, observed or calculated, expressing the result of a test or analysis, shall be rounded off in accordance with IS 2 : 2022 'Rules for rounding off numerical values (*second revision*)'. The number of significant places retained in the rounded off value should be the same as that of the specified value in this standard.

*Indian Standard***TELESCOPIC BALL BEARING DRAWER SLIDE —
SPECIFICATION****1 SCOPE**

1.1 This standard lays down the requirements for materials, dimensions, finish and functional performance of telescopic ball bearing drawer slide and covers all types of extensions.

1.2 This standard does not cover requirements for soft closing drawer slides.

2 REFERENCES

The standards listed in Annex A contain provisions which through reference in this text, constitute provisions of this standard. At the time of publication, the editions indicated were valid. All standards are subject to revision and parties to agreements based on this standard are encouraged to investigate the possibility of applying the most recent edition of the standards indicated in Annex A.

3 CLASSIFICATION

Telescopic ball bearing drawer slide shall be of the following classes based on minimum loading capacity and usage as given in Table 1.

4 DIMENSIONS AND TOLERANCES

4.1 The size of the telescopic ball bearing slide shall be denoted by the length of the telescopic ball bearing slide (L) in mm. Telescopic ball bearing drawer slide shall be of the following sizes based on length of the outer channel: 250 mm, 300 mm, 350 mm, 400 mm, 450 mm, 500 mm, 550 mm, 600 mm, 650 mm and 700 mm.

4.2 Typical shape of telescopic ball bearing slide is as shown in Fig. 1. The leading dimensions of various size of telescopic ball bearing slide and tolerances thereon shall be as given in Table 2.

5 COMPONENTS AND MANUFACTURE**5.1 General**

All metal components of telescopic ball bearing slide shall be conforming to IS 513 (Part 1) or IS 513 (Part 2) or any other material conforming to relevant Indian Standards may be used.

Table 1 Classification of Drawer Slide
(Clause 3)

Sl No.	Class	Minimum Loading capacity kg	Recommended usage
(1)	(2)	(3)	(4)
i)	Light duty	30	Residential use
ii)	Medium duty	45	Institutional uses, hostels and colleges
iii)	Heavy duty	60	Industry or commercial uses
iv)	Super heavy duty	120	Tool cabinets and industrial work stations

5.2 Outer Channel

- Outer channel shall be straight, and there shall be no burr or scratch marks in ball groove area.
- Length of outer channel in telescopic ball bearing slide of different sizes shall be as specified in Table 2.
- Mounting holes shall be minimum 4 mm in diameter.

5.3 Internal Channel

- Internal channel shall be straight, and there shall be no burr or scratch marks in ball groove area.
- Length of internal channel in telescopic ball bearing slide of different sizes shall be specified in Table 2.

5.4 Track

- Track shall be straight, and there shall be no burr or scratch marks in ball groove area.
- Length of track in telescopic ball bearing slide of different sizes shall be as specified in Table 2.
- Mounting holes shall be minimum 4 mm in diameter.

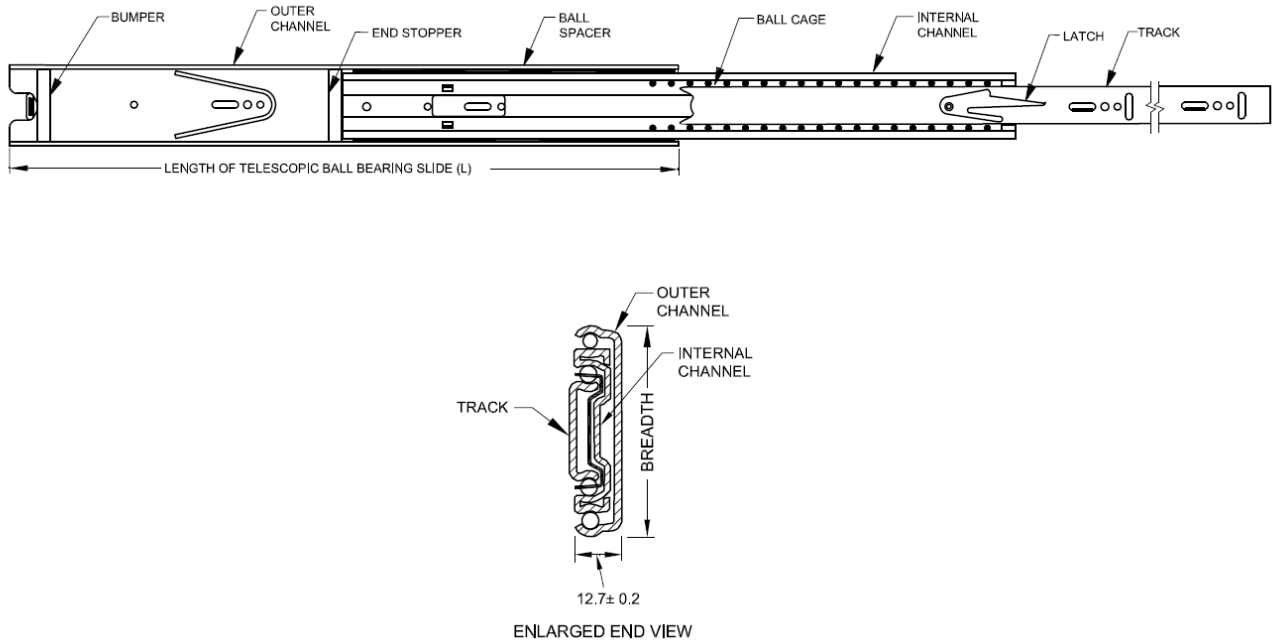

FIG. 1 TYPICAL SKETCH OF TELESCOPIC BALL BEARING SLIDE

5.5 Ball Cage

- a) Ball cage shall be straight, and there shall be no sharp edges or scratch marks in ball area.
- b) Length of ball cage in telescopic ball bearing slide of different sizes shall be as specified in Table 2.

5.6 Ball Spacer

- a) Plastic material may be used for manufacturing of ball spacer.
- b) Ball Spacer shall be straight with allowed deviation of length/100, without any sharp edges.
- c) Length of ball spacer in telescopic ball bearing slide of different sizes shall be specified in Table 2

5.7 End Stopper

- a) Plastic material may be used for manufacturing of end stopper.
- b) End stopper shall have no sharp edges on parts.
- c) End stopper fitment shall be with fixed rivet or shall have secondary locking.

5.8 Bumper

- a) Plastic material may be used for manufacturing of latch.

- b) Bumper shall have no sharp edges on parts.

- c) Bumper shall be capable of locking/unlocking the telescopic ball bearing slide by application of $18\text{ N} \pm 10\text{ N}$ force.

5.9 Latch

- a) Plastic material may be used for manufacturing of latch.
- b) Latch shall have no sharp edges on parts.
- c) Latch fitment shall have fixed riveting.

5.10 Rivets

- a) Rivets shall have no sharp edges on parts.
- b) Rivets shall be made from mild steel material conforming to IS 280 or any other material may be used conforming to relevant Indian Standards.
- c) Dimension of the rivets shall be as per manufacturer's design.

5.11 Ball

- a) The balls shall be as per IS 2898 (Part 1).
- b) Surface hardness of ball shall be $63 \pm 3\text{ HRC}$.
- c) Minimum quantity of ball shall be as specified in Table 3.
- d) No crack should be seen on surface.
- e) The ball shall have a minimum diameter of 4.2 mm.

Table 2 Dimensional Requirements of Telescopic Ball Bearing Slide

[Clauses 4.2, 5.2 (b), 5.3 (b), 5.4 (b), 5.5 (b) and 5.6 (c)]

All dimensions in millimetres

Sl No.	Component	Breadth	Thickness	Minimum Length of Size										Tolerance on Length
				250	300	350	400	450	500	550	600	650	700	
(1)	(2)	(3)	(4)	(5)	(6)	(7)	(8)	(9)	(10)	(11)	(12)	(13)	(14)	(15)
i)	Internal channel	-	1.2	232	282	332	382	432	482	532	582	632	682	± 1
ii)	Outer channel	≥ 45	1.2	250	300	350	400	450	500	550	600	650	700	± 1
iii)	Track up to 550 mm	≥ 24	1.0	247	297	347	397	447	497	547	-	-	-	± 1
iv)	Track from 600 mm onwards	≥ 24	1.5	-	-	-	-	-	-	-	597	597	697	+ 1
v)	Ball cage	≥ 27	0.6	73	99	124	150	175	200	226	251	251	302	± 1
vi)	Ball spacer	-	-	124	149	174	200	225	251	276	301	327	352	± 1

NOTE — Thickness of material mentioned may be modified as per the agreement between the purchaser and the manufacturer as long as the functional requirements as per this standard are met. The tolerance given in the respective Indian Standard shall apply on thickness.

Table 3 Minimum Number of Balls per Slide
[Clause 5.11 (c)]

All dimensions in millimetres

Sl No.	Positioning	Minimum No. of Ball for Telescopic Ball Bearing Slide Size									
		250	300	350	400	450	500	550	600	650	700
(1)	(2)	(3)	(4)	(5)	(6)	(7)	(8)	(9)	(10)	(11)	(12)
i)	Internal channel to ball cage	12	16	20	24	28	32	36	40	44	48
ii)	Outer channel to Ball spacer	8	8	12	16	16	16	22	22	28	28

5.12 Grease (Lubrication)

Food grade grease is applied in the ball movement area for smooth movement.

5.13 Mounting Holes

The number of mounting holes to be punched in different sizes of telescopic ball bearing slides may depend on the size of the slide but shall be a minimum of 3 holes. All type of holes (vertical, horizontal and round) shall be provided with arrangement for adjustment during fitment.

6 GENERAL TEST REQUIREMENTS

6.1 Preparatory Measures

Telescopic ball bearings, to be tested, shall be assembled according to the mounting instructions provided by the manufacturer. Where mounting instructions are not provided, the most unfavorable assembly method shall be selected. Before starting the test, the pullout shall be systematically examined by visual inspection. All detected defects/special features shall be recorded, in order to establish that the defects are not induced.

6.2 Limiting Deviations

The following deviations are applicable to the testing equipment and tests:

- a) Force : ± 5 percent
- b) Speed : ± 5 percent
- c) Weights : ± 3 percent
- d) Dimension : ± 3 mm

6.3 Application of Forces

The forces in the static load tests shall be applied sufficiently slowly to ensure that negligible dynamic force is applied. Each force shall be maintained for not less than 10 s and not more than 15 s. The forces in durability tests shall be applied at a rate to ensure that excessive heating does not occur. The force shall be positioned with an accuracy ± 5 mm.

6.4 Testing Equipment

The test equipment should not prevent any deformation of the pullout, which means that, the equipment should be so flexible that it adjusts itself to the deformation of the pull-out during the test.

6.5 Sequence of testing

The sequence of testing, which shall be done on the same sample for evaluating the performance of the telescopic ball bearing slide, shall be done as given below:

- a) Vertical load test
- b) Horizontal load test
- c) Durability test
- d) Deflection test
- e) Slam test

7 VERTICAL LOAD TEST

7.1 Test Set-Up

The vertical load test shall be conducted in a test jig as shown in Fig. 2. Loading of the drawer shall be done according to the loading capacity (weight of drawer + additional weight). The vertical load, F applied shall be given below:

<i>Loading Capacity</i>	<i>Vertical Load, F</i>
<i>kg</i>	<i>N</i>
(1)	(2)
30	100
45	150
60	200
120	200

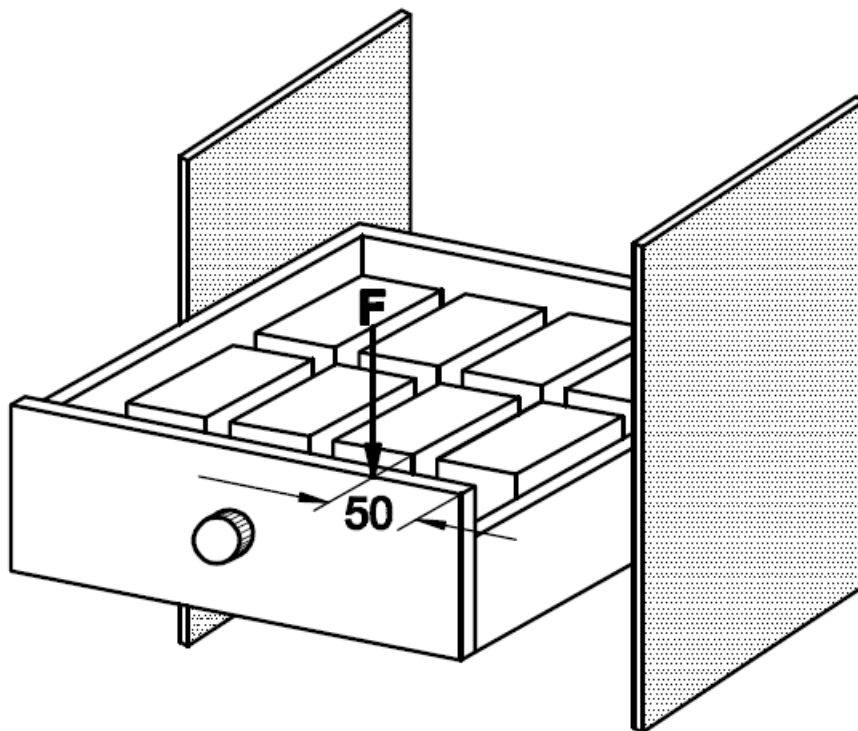

FIG. 2 TEST SET-UP FOR VERTICAL LOAD TEST

7.2 Procedure

The loading frequency shall be 5 times per side, each for 5 s with interim breaks of at least 15 s. The loading shall be applied at the upper edge of the drawer front panel, 50 mm from the side. The load

direction shall be vertically downwards, with the drawer in fully extended position.

7.3 Requirement

Telescopic ball bearing slide or parts of it shall not become detached.

8 HORIZONTAL LOAD TEST

8.1 Test Set Up

The test shall be conducted in a test jig as shown in the test shall be conducted in a test jig as shown in Fig. 3. Loading of the drawer shall be done according to the loading capacity (weight of drawer + additional weight). The horizontal load, F applied shall as per table given below:

<i>Loading Capacity</i>	<i>Horizontal Load, F</i>
<i>kg</i>	<i>N</i>
(1)	(2)
30	50
45	75
60	100
120	100

8.2 Procedure

The loading frequency shall be 5 times per side,

each for 5 s with interim breaks at least 15 s. The loading shall be applied at a point halfway on the front panel horizontally and perpendicular to the pull out direction. The load direction shall be horizontal inwards, with the drawer in fully extended position.

8.3 Requirement

Telescopic ball bearing slide or parts of it shall not become detached.

9 DURABILITY TEST

9.1 Test Set-Up

The durability test shall be conducted in the test jig as shown in Fig. 4. Drawer shall be loaded with typing paper or an equivalent alternative. In cases where it is not possible to achieve the loading capacity with paper, the additional mass shall be steel. Open and close the extension element gently for the number of cycles given below:

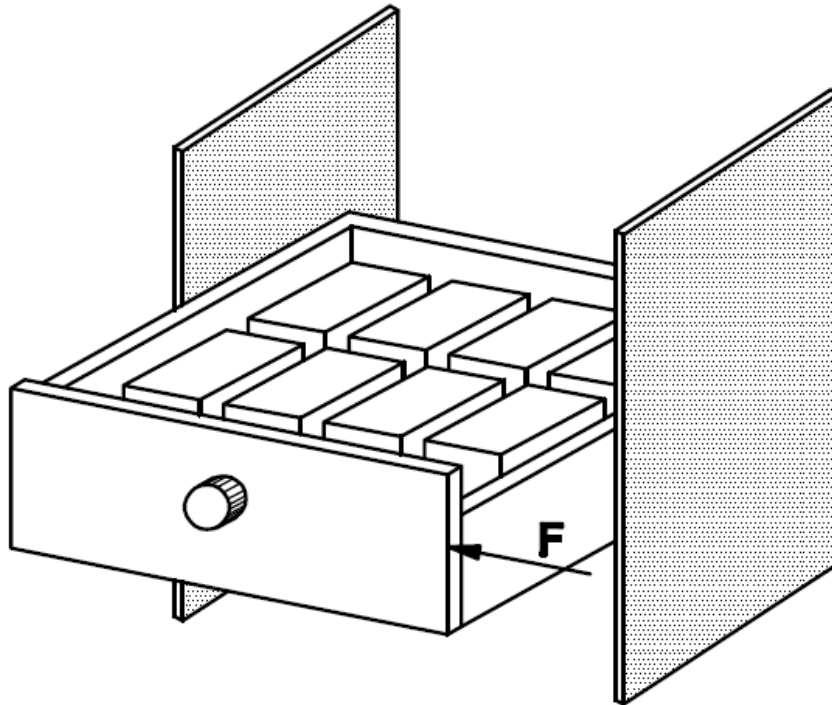

FIG. 3 TEST SET-UP FOR HORIZONTAL LOAD TEST

<i>Class</i>	<i>Number of Cycles</i>
(1)	(2)
Light duty	20 000
Medium duty	50 000
Heavy duty	75 000
Super Heavy duty	75 000

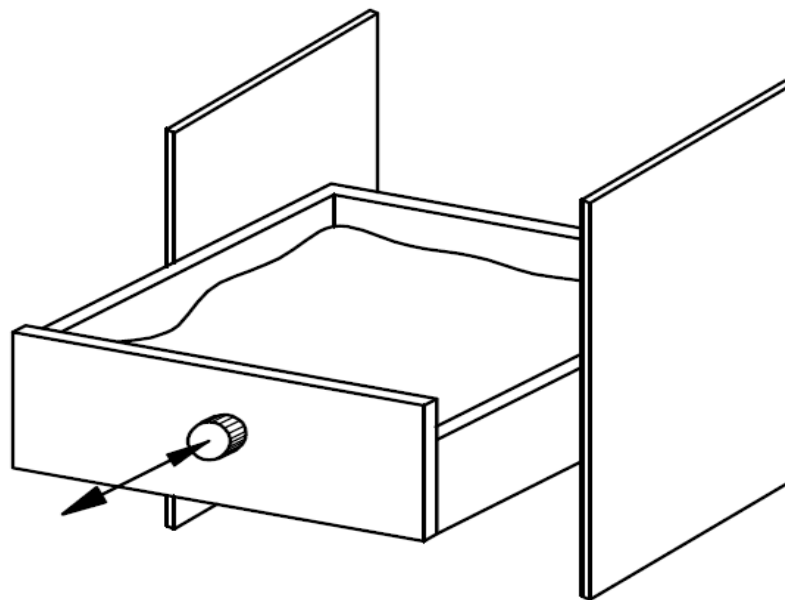

FIG. 4 TEST SET-UP FOR DURABILITY TEST

9.2 Procedure

Open and close the telescopic ball bearing slide via the force application with the speed v (in m/s) = $35 / (95 + \text{loading capacity in kg})$. The stroke length for this test is as given below:

- When opening — up to 50 mm before stopping in the open position.
- When closing — completely closed without hard impact or 15 mm before completely closed position.

9.3 Requirement

- Damages like ruptures and cracks shall not be observed after the test.
- Telescopic ball bearing slide or parts of it shall not become detached.
- The telescopic ball bearing slide shall fulfil its function without any malfunction.

10 DEFLECTION TEST

The deflection test is to be conducted after the sample has passed the durability test.

10.1 Test Set-Up

The deflection of front shall be measured as shown in Fig. 5.

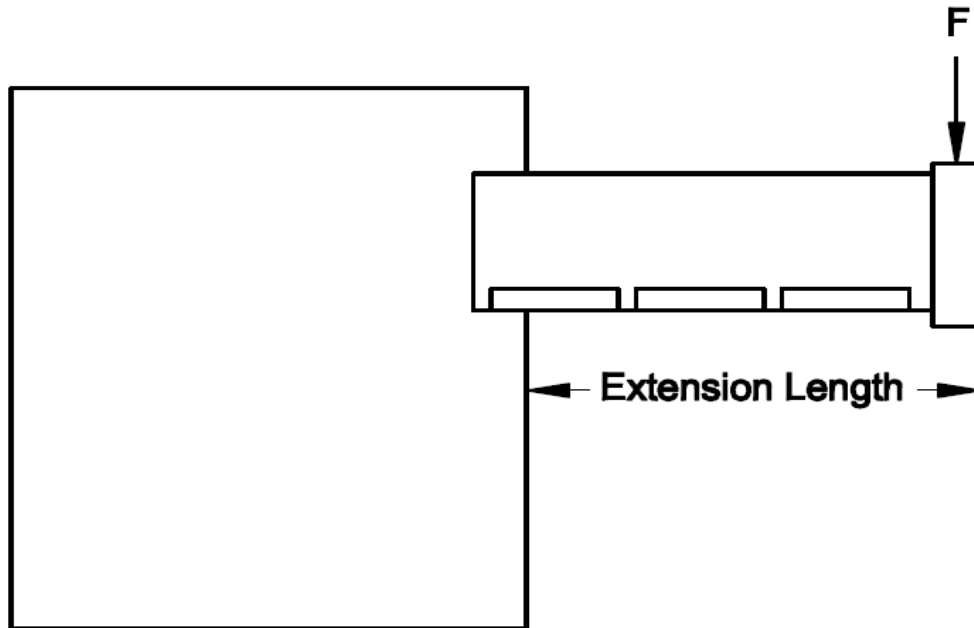

FIG. 5 TEST SET-UP FOR DEFLECTION TEST

10.2 Procedure

The net deflection of front shall measure to the vertical position at the middle of the top of the front in fully open condition.

Net deflection = Deflection with fully loaded condition - Deflection with empty condition.

10.3 Requirement

The deflection of front shall not exceed 5 percent of the extension length.

11 SLAM TEST

Before the slam test, the vertical load test as per 7 and horizontal load test as per 8 shall be performed on the same sample which has passed the deflection of front test.

11.1 Test Set-Up

The opening or closing movement shall be done in such a way that the drawer moves freely to open position and 10 mm before its shut position. Loading of the drawer shall be done according to the

loading capacity (weight of drawer + additional weight).

11.2 Test Procedure

The test may be repeated 3 times each with and without loading. The loading may be applied by an attachment at the height of intended handle or at the centre of the drawer on the front panel of the drawer. The test is conducted with the speed v (in m/s) = $80/(95 + \text{loading capacity in kg})$. After each impact cycle, the weight may be redistributed evenly across the surface of the drawer.

11.3 Requirement

The telescopic ball bearing slide shall fulfill its function and there shall not be visible damages such as ruptures and cracks after the test.

12 FINISH

Unless otherwise specified, telescopic ball bearing slide shall be finished bright with smooth surfaces and shall pass minimum 72 h salt spray test as per IS 9844. Minimum coating thickness shall be as

given below except for rivets, cutting edge of ball cage area where zinc coating is not present and ball movement area:

- a) Zinc Plating — 4 μ .
- b) Cathode electro-deposition coating (CED) or Black coating — 10 μ .

13 PACKING

Each set of telescopic ball bearing slide each set shall be packed in low density poly ethylene (LDPE) or laminate. Ten sets of telescopic ball bearing slide shall be packed in corrugated box or in any other approved packing as agreed to between the manufacturer and the purchaser. The manufacturer shall provide mounting instructions in a sheet, to be placed in the packing.

14 MARKING

14.1 Each set or box shall be legibly and indelibly marked with the following:

- a) Manufacturer's name and his registered trade-mark, if any;
- b) Net quantity, in numbers;
- c) Size;
- d) Declared load (load level) of the telescopic ball bearing drawer slide;
- e) Batch/lot number;

- f) Date of manufacture, and
- g) Address of the manufacturer.

14.2 BIS Certification Marking

Each unit shall also be marked with the Standard Mark.

14.2.1 The product(s) conforming to the requirements of this standard may be certified as per the conformity assessment schemes under the provisions of the *Bureau of Indian Standards Act, 2016* and the Rules and Regulations framed thereunder, and the product(s) may be marked with the Standard Mark.

15 SAMPLING AND CRITERION FOR CONFORMITY

15.1 Scale of Sampling

15.1.1 Lot

In any consignment, all the drawer slides of the same type, size and load level, manufactured from similar materials under similar conditions of manufacture in a shift, shall constitute a lot.

15.1.2 The number of drawer slides, to be selected from a lot, shall depend upon the size of the lot and shall be in accordance with Table 4.

Table 4 Scale of Sampling and Criterion for Conformity
(Clauses 15.1.2, 15.2.1 and 15.2.2)

Sl No.	Lot Size	Sample Size	Acceptance No.	Sample Size for Performance test
(1)	(2)	(3)	(4)	(5)
i)	Up to 1 000	5	0	1
ii)	1 001 to 3 000	8	0	1
iii)	3 001 to 5 000	13	1	2
iv)	5 001 and above	20	2	2

15.1.3 These drawer slides shall be selected at random. In order to ensure the randomness of selection, procedure given in IS 4905 may be followed.

15.2 Number of Tests and Criteria for Conformity

15.2.1 All the Telescopic Ball bearing drawer slide selected in accordance with col (2) and (3) of

Table 4 shall be subjected to tests for dimensional requirements. Any telescopic ball bearing drawer slide failing to meet one or more of the requirements shall be considered as 'defective'. If the number of defective telescopic ball bearing drawer slide among those tested does not exceed the corresponding number given in column 4) of Table 4, the lot shall be considered as conforming to the dimensional requirements.

IS 17954 : 2023

15.2.2 The lot which has been found as conforming to the dimensional requirements shall then be subjected to performance requirements (vertical load test, horizontal load test, durability test, deflection test, slam test and finish). For this purpose, the number of telescopic ball bearing drawer slides to be selected shall be in accordance with col (2) and col (5) of Table 4. If the number of defective telescopic ball bearing drawer slide among

those tested does not exceed the corresponding number given in column 4 of Table 4, the lot shall be considered as conforming to performance requirements.

15.2.3 A lot shall be considered as conforming to the requirement of this standard if **15.2.1** and **15.2.2** are satisfied.

ANNEX A
(Clause 2)

LIST OF REFERRED INDIAN STANDARDS

<i>IS No.</i>	<i>Title</i>	<i>IS No.</i>	<i>Title</i>
IS 513	Cold reduced carbon steel sheet and strips:	IS 4905 : 2015/ ISO 24153 : 2009	Random sampling and randomization procedures (<i>first revision</i>)
(Part 1) : 2016	Cold forming and drawing purposes (<i>sixth revision</i>)	IS 9844 : 1981	Method of testing corrosion resistance of electroplated and anodized aluminium coatings by neutral salt spray test
(Part 2) : 2016	High tensile and multi-phase steel (<i>sixth revision</i>)	IS 280 : 2006	Mild steel wire for general engineering purpose (<i>fourth revision</i>)
IS 2898	Rolling bearings — Balls		
(Part 1 : 2019/ ISO 3290-1 : 2014	steel balls (<i>second revision</i>)		

ANNEX B
(Foreword)

COMMITTEE COMPOSITION

Builder's Hardware Sectional Committee, CED 15

<i>Organization</i>	<i>Representative(s)</i>
In Personal Capacity (1421, Sector A, Pocket B & C, Vasant Kunj, New Delhi 110070)	SHRI B. MAJUMDAR (Chairperson)
Allied Anodisers, Kolkata	SHRI SUSHIL TAWAR
Appex Association of DDA Colonies (Regd), Delhi	SHRI R. P. AGRAWAL SHRI R. R. SHARMA (<i>Alternate</i>)
Argent Industries, New Delhi	SHRI ANIL CHADHA SRIMATI VANITA CHADHA (<i>Alternate</i>)
Builders' Association of India, New Delhi	SHRI NEERAV PARMAR SHRI H. S. PSRICHA (<i>Alternate</i>)
Central Public Works Department, New Delhi	SHRI M. K. MALLICK SHRI DIVAKAR AGRAWAL (<i>Alternate</i>)
CSIR - Central Building Research Institute, Roorkee	SHRI ASHOK KUMAR SHRI S. K. NEGI (<i>Alternate</i>)
D. P. Garg and Company Pvt Ltd, Noida	SHRI S. M. GARG SHRI R. C. MALHOTRA (<i>Alternate</i>)
Dormakaba India Pvt Ltd, New Delhi	SHRI MANAV GULATI SHRI MANOJ (<i>Alternate</i>)
Engineering Projects (India) Ltd, New Delhi	REPRESENTATIVE
Garnish Traders, New Delhi	SHRI H. S. SETHI MS HARMEET SETHI (<i>Alternate</i>)
Godrej and Boyce Mfg Co Limited, Mumbai	SHRI KSHITIJ R. GAIKAR SHRI VINAYAK G. NALGIRKAR (<i>Alternate</i>)
Hindalco Industries Ltd, Sonbhadra	SHRI JAYANTA RANASINGH DR SAIKAT ADHIKARI (<i>Alternate</i>)
Hettich India Pvt Ltd, Mumbai	SHRI VIRENDRA KUMAR DR PANKAJ PANCHAL (<i>Alternate</i>)
Intertek India Pvt Ltd, Gurugram	SHRI POORNESH KUMAR CHATURVEDI SHRI GARISH MALHOTRA (<i>Alternate</i>)
Jindal Stainless Ltd, New Delhi	SHRI RAJIV GUPTA MS NISHA GOEL (<i>Alternate</i>)
Kich Architectural Products Pvt Ltd, Rajkot	SHRI BHAVDEEP K. NAKUM SHRI ANIL VANJANI (<i>Alternate</i>)
LGF Sysmac (India) Pvt Ltd, Pune	SHRI ASHIM CHUGH

<i>Organization</i>	<i>Representative(s)</i>
M C Mowjee and Company Pvt Ltd, Kolkata	SHRI RUSHD MOWJEE SHRI SAJID MOWJEE (<i>Alternate</i>)
MECH (India) Industries, Delhi	SHRI SUDHIR BATRA SHRI SAMEER ARORA (<i>Alternate</i>)
MES Builders Association of India	REPRESENTATIVE
Metallurgical Services Pvt Ltd	SHRI NAGENDRA HEBBAR
Military Engineer Services, Engineer-in-Chief's Branch, Integrated HQ of MoD (Army), New Delhi	SHRI SOMESH KUMAR COL N. CHAKRAVORTY (<i>Alternate</i>)
Ministry of Micro, Small and Medium Enterprises, New Delhi	SHRI U. C. SHUKLA
Mukund Overseas, Mumbai	SHRI MUKUND THAKKAR SHRI DINESH M. THAKKAR (<i>Alternate</i>)
School of Planning and Architecture, New Delhi	REPRESENTATIVE
Shakti Hormann Pvt Ltd, Telangana	SHRI SYED MOHAMED SHRI MAHESH SINGH (<i>Alternate</i>)
South India Agencies	REPRESENTATIVE
Synergy Aluminium Pvt Ltd	REPRESENTATIVE
The Indian Institute of Architects, Mumbai	SHRI ABHIJIT RAY
BIS Directorate General	SHRI SANJAY PANT, SCIENTIST 'F' AND HEAD (CIVIL ENGINEERING) [REPRESENTING DIRECTOR GENERAL (<i>Ex-officio</i>)]

Member Secretary

DR MANOJ KUMAR RAJAK
SCIENTIST 'D'/JOINT DIRECTOR
(CIVIL ENGINEERING), BIS
AND
SHRI SINAM HUDSON SINGH
SCIENTIST 'D'/JOINT DIRECTOR
(CIVIL ENGINEERING), BIS

Bureau of Indian Standards

BIS is a statutory institution established under the *Bureau of Indian Standards Act, 2016* to promote harmonious development of the activities of standardization, marking and quality certification of goods and attending to connected matters in the country.

Copyright

BIS has the copyright of all its publications. No part of these publications may be reproduced in any form without the prior permission in writing of BIS. This does not preclude the free use, in the course of implementing the standard, of necessary details, such as symbols and sizes, type or grade designations. Enquiries relating to copyright be addressed to the Head (Publication & Sales), BIS.

Review of Indian Standards

Amendments are issued to standards as the need arises on the basis of comments. Standards are also reviewed periodically; a standard along with amendments is reaffirmed when such review indicates that no changes are needed; if the review indicates that changes are needed, it is taken up for revision. Users of Indian Standards should ascertain that they are in possession of the latest amendments or edition by referring to the website-www.bis.gov.in or www.standardsbis.in.

This Indian Standard has been developed from Doc No.: CED 15 (17622).

Amendments Issued Since Publication

Amend No.	Date of Issue	Text Affected

BUREAU OF INDIAN STANDARDS

Headquarters:

Manak Bhavan, 9 Bahadur Shah Zafar Marg, New Delhi 110002

Telephones: 2323 0131, 2323 3375, 2323 9402

Website: www.bis.gov.in

Regional Offices:

	Telephones
Central : 601/A, Konnectus Tower -1, 6 th Floor, DMRC Building, Bhavbhuti Marg, New Delhi 110002	{ 2323 7617
Eastern : 8 th Floor, Plot No 7/7 & 7/8, CP Block, Sector V, Salt Lake, Kolkata, West Bengal 700091	{ 2367 0012 2320 9474
Northern : Plot No. 4-A, Sector 27-B, Madhya Marg, Chandigarh 160019	{ 265 9930
Southern : C.I.T. Campus, IV Cross Road, Taramani, Chennai 600113	{ 2254 1442 2254 1216
Western : Plot No. E-9, Road No.-8, MIDC, Andheri (East), Mumbai 400093	{ 2821 8093

Branches : AHMEDABAD. BENGALURU. BHOPAL. BHUBANESHWAR. CHANDIGARH. CHENNAI. COIMBATORE. DEHRADUN. DELHI. FARIDABAD. GHAZIABAD. GUWAHATI. HIMACHAL PRADESH. HUBLI. HYDERABAD. JAIPUR. JAMMU & KASHMIR. JAMSHEDPUR. KOCHI. KOLKATA. LUCKNOW. MADURAI. MUMBAI. NAGPUR. NOIDA. PANIPAT. PATNA. PUNE. RAIPUR. RAJKOT. SURAT. VISAKHAPATNAM.