

विद्युत नियुक्ति के लिए केबल ट्रकिंग
प्रणालियाँ और केबल वाहिनी प्रणालियाँ
भाग 2 दीवारों पर अथवा सीलिंग पर लगाने के लिए
केबल ट्रकिंग एवं केबल वाहिनी प्रणालियाँ
अनुभाग 1 विवरणात्मक अपेक्षाएँ
(पहला पुनरीक्षण)

**Cable Trunking Systems and Cable
Ducting Systems for Electrical
Installations**

**Part 2 Cable Trunking Systems and
Cable Ducting Systems Intended for
Mounting on Walls and Ceilings**

Section 1 Particular Requirements

(*First Revision*)

ICS 29.060.01; 29.120.10

© BIS 2023

© IEC 2017



भारतीय मानक ब्यूरो

BUREAU OF INDIAN STANDARDS

मानक भवन, 9 बहादुर शाह ज़फर मार्ग, नई दिल्ली - 110002

MANAK BHAVAN, 9 BAHADUR SHAH ZAFAR MARG

NEW DELHI - 110002

www.bis.gov.in www.standardsbis.in

NATIONAL FOREWORD

This Indian Standard (Part 2/Sec 1) (First Revision) which is identical with IEC 61084-2-1 : 2017 'Cable trunking systems and cable ducting systems for electrical installations — Part 2-1: Particular requirements — Cable trunking systems and cable ducting systems intended for mounting on walls and ceilings' issued by the International Electrotechnical Commission (IEC) was adopted by the Bureau of Indian Standards on the recommendation of the Electrical Wiring Accessories Sectional Committee and approval of the Electrotechnical Division Council.

This standard was first published in 2001. The first revision of this standard has been undertaken to align it with the latest version of IEC 618084-2-1 to make pace with the latest developments that have taken place at international level.

The text of the IEC standard has been approved as suitable for publication as an Indian Standard without deviations. Certain conventions are, however, not identical to those used in Indian Standards. Attention is particularly drawn to the following:

- a) Wherever the words 'International Standard' appears referring to this standard, they should be read as 'Indian Standard'; and
- b) Comma (,) has been used as a decimal marker, while in Indian Standards the current practice is to use a point (.) as the decimal marker.

In this adopted standard, reference appears to International Standards for which Indian Standards also exists. The corresponding Indian Standards, which are to be substituted, are listed below along with their degree of equivalence for the editions indicated:

<i>International Standard</i>	<i>Corresponding Indian Standard</i>	<i>Degree of Equivalence</i>
IEC 60068-2-75 : 2014 Environmental testing — Part 2-75: Tests — Test Eh: Hammer tests	IS 9000 (Part 7/Sec 7) : 2020/IEC 60068-2-75 : 2014 Environmental testing: Part 7 Tests section 7 Test Eh: Hammer tests (<i>first revision</i>)	Identical
IEC 60228 : 2004 Conductors of insulated cables	IS 8130 : 2013/IEC 60228 : 2004 Conductors for insulated electric cables and flexible cords — Specification (<i>second revision</i>)	Identical
IEC 61084-1 : 2017 Cable trunking systems and cable ducting systems for electrical installations — Part 1: General requirements	IS 14927 (Part 1) : 2023/IEC 61084-1 : 2017 Cable trunking and ducting systems for electrical installations: Part 1 General requirements (<i>first revision</i>)	Identical
ISO 535 : 2014 Paper and board — Determination of water absorptiveness — Cobb method	IS 1060 (Part 5/Sec 4) : 2014/ISO 535 : 1991 Methods of sampling and test for paper and allied products: Part 5 Methods of test for paper and board, Section 4 Determination of water absorptiveness — Cobb method	Identical

(Continued on third cover)

CONTENTS

1	Scope	1
2	Normative references	1
3	Terms and definitions	1
4	General requirements	2
5	General conditions for tests	2
6	Classification	2
7	Marking and documentation	4
8	Dimensions	4
9	Construction	4
10	Mechanical properties	6
11	Electrical properties	11
12	Thermal properties	11
13	Fire hazard	11
14	External influences	12
15	Electromagnetic compatibility	12
	Annex A (informative) Types of cable trunking systems (CTS) and cable ducting systems (CDS).....	20
	Annex B (normative) CTS/CDS IK code	21
	Figure 101 – Types and application of CTS/CDS for wall or ceiling installation	12
	Figure 102 – Arrangement for cable support test according to 10.2.2	13
	Figure 103 – Arrangement for cable support test according to 10.2.3	13
	Figure 104 – Arrangement for cable support test according to 10.2.4	14
	Figure 105 – Arrangement for cable support test according to 10.2.5	14
	Figure 106 – Impact test for installation and application – Principles for arrangement	15
	Figure 107 – Impact test for installation and application – Examples for arrangement	17
	Figure 108 – Arrangement for linear deflection test	18
	Figure 109 – Example of arrangement for CDS compression test	19

Indian Standard

**CABLE TRUNKING SYSTEMS AND CABLE DUCTING
SYSTEMS FOR ELECTRICAL INSTALLATIONS**

**PART 2-1 PARTICULAR REQUIREMENTS CABLE TRUNKING
SYSTEMS AND CABLE DUCTING SYSTEMS INTENDED FOR
MOUNTING ON WALLS AND CEILINGS**

(First Revision)

1 Scope

This part of the IEC 61084 series specifies requirements and tests for cable trunking systems (CTS) and cable ducting systems (CDS) intended for the accommodation, and where necessary for the electrically protective separation, of insulated conductors, cables and possibly other electrical equipment in electrical and/or communication systems installations. The maximum voltage of these installations is 1 000 V AC and 1 500 V DC.

These systems are intended for mounting on walls and/or ceilings. They can be embedded, installed in a flush or semi-flush state, surface mounted or mounted away from the surface using fixing devices.

This document does not apply to conduit systems, cable tray systems, cable ladder systems, power track systems or equipment covered by other standards.

2 Normative references

This clause of Part 1 is applicable, except as follows:

Addition:

IEC 60068-2-75:2014, *Environmental testing – Part 2-75: Tests – Test Eh: Hammer tests*

IEC 60228:2004, *Conductors of insulated cables*

IEC 61084-1:2017, *Cable trunking systems and cable ducting systems for electrical installations – Part 1: General requirements*

ISO 535:2014, *Paper and board – Determination of water absorptiveness – Cobb method*

ISO 536:2012, *Paper and board – Determination of grammage*

3 Terms and definitions

This clause of Part 1 is applicable, except as follows:

3.1 Replace Note 1 to entry by:

Note 1 to entry: Different types of CTS are shown in Figure 101 and explained in Annexe A.

3.2 Replace Note 1 to entry by:

Note 1 to entry: Different types of CDS are shown in Figure 101 and explained in Annex A.

Addition:

3.101
type 2 CTS/CDS
distribution CTS/CDS

CTS/CDS which provides at least the following functions:

- in line junction between two trunking lengths or ducting lengths,
- internal and external changes of direction between two trunking lengths or ducting lengths,
- flat change of direction between two trunking lengths or ducting lengths with the exception of certain systems where such a function is not required e.g. skirting CTS/CDS,
- "T" function between three trunking lengths or ducting lengths with the exception of certain systems where such a function is not required e.g. bench CTS,
- termination of a trunking length or a ducting length

3.102
type 3 CTS/CDS
installation CTS/CDS

distribution CTS/CDS which provides in addition apparatus mounting function

3.103
type 1 CTS/CDS

CTS/CDS that cannot be defined as a type 2 CTS/CDS or as a type 3 CTS/CDS

3.104
surface mounting CTS/CDS

CTS/CDS intended for mounting on a surface

3.105
flush-mounting CTS/CDS

CTS/CDS intended for mounting flush with the surface so that at least 90 % of the product depth is recessed below the finished surface when installed according to manufacturer's instructions

3.106
semi-flush mounting CTS/CDS

CTS/CDS intended to fit within a mounting surface so that more than 10 % of the product depth projects from the finished surface

4 General requirements

This clause of Part 1 is applicable.

5 General conditions for tests

This clause of Part 1 is applicable.

6 Classification

This clause of Part 1 is applicable, except as follows:

Additional subclauses:

6.101 According to the intended installation positions

NOTE More than one classification can be declared.

6.101.1 CDS embedded in the wall or ceiling

6.101.2 CTS/CDS flush in the wall or ceiling

6.101.2.1 CTS/CDS flush in the wall

6.101.2.2 CTS/CDS flush in the ceiling

6.101.3 CTS/CDS semi-flush or surface-mounted on the wall or ceiling

6.101.3.1 CTS/CDS semi-flush or surface-mounted on the wall

6.101.3.2 CTS/CDS semi-flush or surface-mounted on the ceiling

6.101.3.3 CTS/CDS wall fixed and supported by the floor

6.101.3.4 CTS/CDS wall fixed and supported by a horizontal surface other than the floor

6.101.4 CTS/CDS mounted away from the wall or ceiling using fixing devices

6.102 According to the prevention of contact between liquids and insulated conductors and live parts in case of CTS/CDS mounted in a skirting position and wet-treatment of floor

6.102.1 Not declared

6.102.2 Relying completely on manufacturer's instructions restricting the installation position of the CTS/CDS

6.102.3 Relying on manufacturer's instructions allowing all installation positions of the CTS/CDS but restricting the position of insulated conductors and live parts in CTS/CDS

6.102.4 Relying on manufacturer's instructions allowing all installation positions of the CTS/CDS and all positions of insulated conductors and live parts in CTS/CDS

NOTE Installation position refers to the distance between CTS/CDS and the floor.

6.103 According to the type

6.103.1 Type 1 CTS/CDS

6.103.2 Type 2 CTS/CDS (distribution CTS/CDS)

6.103.3 Type 3 CTS/CDS (installation CTS/CDS)

6.104 According to resistance to compression for CDS

6.104.1 CDS for compression 125 N

6.104.2 CDS for compression 320 N

6.104.3 CDS for compression 750 N

6.104.4 CDS for compression 1 250 N

6.104.5 CDS for compression 4 000 N

7 Marking and documentation

This clause of Part 1 is applicable, except as follows:

7.3 Replacement:

7.3 The manufacturer shall provide in his documentation all information necessary for the proper and safe installation and use. It shall include:

- components of the system;
- function of the system components and their assemblies;
- classification of the system in accordance with Clause 6;
- for type 1 CTS/CDS the list of functions;
- linear impedance, in Ω/m , of trunking length or ducting length of system declared according to 6.5.1;
- rated voltage of CTS/CDS declared according to 6.6.2;
- usable cross sectional area, in mm^2 , for cables of the CTS/CDS;

NOTE Certain system components when mounted can reduce the usable cross sectional area for cables.

- instructions to reach the declared classification and functions of the system. These instructions shall include the recommended installation positioning for the CTS/CDS to ensure that the declared IP classification is maintained after installation.

Compliance is checked by inspection.

8 Dimensions

This clause of Part 1 is applicable, except as follows:

Addition:

There are no dimension requirements.

9 Construction

This clause of Part 1 is applicable, except as follows:

Additional subclauses:

9.101 Assembling

System components shall fit correctly.

Compliance is checked by inspection.

9.102 Contact between liquids and insulated conductors and live parts

CTS/CDS declared according to 6.102.2, 6.102.3 or 6.102.4 shall prevent liquids coming into contact with insulated conductors and live parts during wet-treatment of floor.

Compliance is checked by inspection and measurement when the area intended to accommodate insulated conductors is at least 10 mm above the floor due to the following reasons:

- design, or
- manufacturer's instructions restricting the installation position of the CTS/CDS, or
- manufacturer's instructions allowing all installation positions of the CTS/CDS but restricting the position of insulated conductors and live parts in CTS/CDS.

In all other cases, compliance is checked by the following test carried out on an assembly or assemblies.

An assembly is made of one or more trunking lengths or ducting lengths with the relevant system component, if any, to fulfil the various functions of the system and prepared according to the manufacturer's instructions. More than one assembly may be necessary to fulfil the various functions of the system. In each direction, the length L of trunking length or ducting length coming out of the functional area associated with the function of the system is as long as the width W of the trunking length or ducting length, or 250 mm, whichever is the greater. The tolerance of L is ± 25 mm.

NOTE 1 Functional area refers, for example, to a fitting, an apparatus mounting device, a junction as shown in Figure 106.

The assembly is fixed according to manufacturer's instructions to an appropriate support. The ends of the assembly are closed according to manufacturer's instructions.

A (5 ± 1) mm wide strip of absorbent paper is placed on the lowest internal surface of CTS/CDS intended for the accommodation of insulated conductors. If this lowest internal surface is horizontal, the strip is placed approximately on the centre line of the surface. The absorbent paper has a water absorptive height longitudinal of 75 mm per 10 min according to ISO 535 and a basis weight of 250 g/m² according to ISO 536. The length of the strip is such that it covers the whole length of the assembly.

NOTE 2 When the tested function of the system includes a change of direction, the length of paper can be made of more than one strip.

Provisions are made such that the absorbent paper makes contact with the lowest internal surface of CTS/CDS intended for the accommodation of insulated conductors along the whole length of the assembly. These provisions shall not influence absorption by the paper.

The assembly is carefully placed in a tray containing water to simulate a $(10, 0/-1)$ mm height of water on the floor.

NOTE 3 For easy measurement of wet area, coloured water can be used.

After (15 ± 1) s, the assembly is removed from the tray and the exterior of the assembly is immediately wiped.

After careful removal of the access covers, if any, the absorbent paper is removed. Within 5 min after the removal of the assembly from the tray, the lengths of the wet areas are measured on the centre line of the strips.

For each tested function, the length of any wet area in the strip of absorbent paper shall be shorter than 50 mm.

10 Mechanical properties

This clause of Part 1 is applicable, except as follows:

10.2 Cable support test

Replacement:

10.2 Cable support test

10.2.1 General test conditions

Each test is made on one new sample of trunking length or ducting length having a length of 250 mm \pm 5 mm.

Trunking length or ducting length having a usable cross sectional area lower than or equal to 500 mm² do not need to be tested.

The sample is securely fixed, using 10 mm external diameter flat metallic washers and metallic screws to a rigid smooth support such as a plywood board 16 mm thick. When 10 mm external diameter is too large, a suitable smaller washer is used. Fixing(s) are positioned at (200 \pm 5) mm centres along the length of the sample.

Within the width of the sample, the fixing is made as close as possible to each side wall. For triangular or similar cross section CTS/CDS, the sample is fixed only to the wall.

If the manufacturer's instructions require the use of cable retainers, the test is carried out using the cable retainers and if possible symmetrically fixed along the length.

The sample is subjected to an evenly distributed load of 1,0 g/mm² of the declared usable area for cables, per metre length. The load is distributed between the compartments proportionally to the declared usable area. The load consists of copper insulated conductors or cables complying with class 5, Table 3 of IEC 60228:2004 or flexible insulated conductors or cables of similar mass per meter.

To allow for settlement of the sample, a pre-load of 10 % of the load is applied and removed after 5 min \pm 30 s. The measurement apparatus is then calibrated to zero. No pre-load is necessary for CTS/CDS classified in accordance with 6.101.3.3.

Non-metallic and composite trunking lengths or non-metallic and composite ducting lengths are tested at the maximum application temperature declared by the manufacturer according to Table 3 of Part 1 with a tolerance of \pm 2 °C.

Insulated conductors or cables of 25 mm² nominal cross section are placed in the sample so that approximately 50 % of the load is achieved. If the dimensions of the compartment do not permit the accommodation of 25 mm² insulated conductor or cable, 2,5 mm² nominal cross section insulated conductors or cables are used. Insulated conductors or cables of 2,5 mm² nominal cross section are placed on top of the larger cables to achieve the total load within a tolerance of \pm 5 g.

The load is applied for 120 min (+5/0) min. After this period, the deflection is measured at approximately the middle of the length.

10.2.2 Test for wall fixed CTS/CDS

This test applies to CTS/CDS declared according to 6.101.3.1 and/or 6.101.3.3.

The trunking length or ducting length is mounted as shown in Figure 102, following 10.2.1.

The vertical deflection F is measured as follows:

- *for rectangular or similar cross section CTS/CDS, on the lower edge as shown in Figure 102a;*
- *for non-rectangular cross section CTS/CDS, as shown in Figure 102b.*

The vertical deflection F shall not exceed 10 % of the external horizontal dimension X , with a maximum of 10 mm. This deflection criteria does not apply to CTS/CDS classified according to 6.101.3.3.

Access covers of CTS, non-removable cable separators, cable retainers and the like shall remain adequately fixed so as to fulfil their intended function.

10.2.3 Additional test for wall fixed CTS/CDS with removable separator

This test applies to CTS/CDS provided with removable separator and declared according to 6.101.3.1 and/or 6.101.3.3.

The trunking length or ducting length is mounted as shown in Figure 103, with one separator inserted in the most unfavourable position, following 10.2.1.

NOTE The most unfavourable position of the separator is generally the lowest intended position.

Access covers of CTS, removable cable separators, cable retainers and the like shall remain adequately fixed so as to fulfil their intended function.

10.2.4 Test for ceiling fixed CTS/CDS

This test applies to CTS/CDS declared according to 6.101.3.2 and/or 6.101.2.2.

The trunking length or ducting length is mounted as shown in Figure 104, following 10.2.1.

The vertical deflection F is measured as follows:

- *for rectangular or similar cross section CTS/CDS, on the lower surface as shown in Figure 104a,*
- *for non-rectangular cross section CTS/CDS, as shown in Figure 104b.*

The vertical deflection F shall not exceed 10 % of the external horizontal dimension X , with a maximum of 10 mm.

Access covers of CTS, non-removable cable separators, cable retainers and the like shall remain adequately fixed so as to fulfil their intended function.

10.2.5 Additional test for ceiling fixed CTS/CDS with removable separator

This test applies to CTS/CDS provided with removable separator and declared according to 6.101.3.2 and/or 6.101.2.2.

The trunking length or ducting length is mounted as shown in Figure 105, with one separator inserted in the most unfavourable position, following 10.2.1.

NOTE The most unfavourable position of the separator is generally in the middle of the width.

Access covers of CTS, removable cable separators, cable retainers and the like shall remain adequately fixed so as to fulfil their intended function.

10.3 Impact test

10.3.2 Impact test for installation and application

Additional subclauses:

10.3.2.101 The test is carried out on an assembly made of one or more trunking lengths or ducting lengths with the relevant system component, if any, to fulfil the various functions of the system and prepared according to the manufacturer's instructions. More than one assembly may be necessary to fulfil the various functions of the system. In each direction, the length L of trunking length or ducting length coming out of the functional area associated with the function of the system is as long as the width W of the trunking length or ducting length, or 250 mm, whichever is the greater. The tolerance of L is ± 25 mm.

NOTE Functional area refers, for example, to a fitting, an apparatus mounting device, a junction as shown in Figure 106.

The samples are mounted on a rigid smooth support such as a plywood board 16 mm thick, with a 50 mm minimum spacing between the assembly and the edge of the support.

Other system components can be included to prevent movements. These system components are the system components to terminate the trunking length or ducting length, if any. When there is no such system component, a system component chosen by the manufacturer is used.

Examples for arrangement are shown in Figure 107.

Before the test non-metallic system components and composite components are aged at the temperature declared according to Table 3 of Part 1 with a tolerance of ± 2 °C for (168 ± 4) h continuously.

10.3.2.102 The impact test apparatus according to Clause 4 of IEC 60068-2-75:2014 is mounted on a solid wall or structure providing sufficient support.

The samples are placed in a cabinet at the temperature declared according to Table 2 with a tolerance of ± 2 °C.

10.3.2.103 After 2 h, each sample is, in turn, removed from the cabinet and immediately placed in position in the impact test apparatus.

At (12 ± 2) s after the removal of the sample from the cabinet, the hammer is allowed to fall so that an impact is applied as far as possible perpendicular to the accessible region of the sample likely to be the weakest. Compliance with impact applied before 10 s provides also compliance with this test of the standard.

NOTE 1 The region likely to be the weakest can be on the relevant system component but can also be on a trunking length or a ducting length.

No impact is applied to knockouts, membranes and the like.

No impact is applied within 50 mm of any open extremity of the sample.

NOTE 2 When another system component has been included at an extremity of the sample to prevent movements, this extremity is still considered open.

Instead of placing the samples in a cabinet and applying the impact at (12 ± 2) s after the removal of the sample from the cabinet, it is allowed to apply the impact in a climatic chamber at the temperature declared according to Table 2 with a tolerance of ± 2 °C on samples placed at this temperature at least for 2 h. Compliance in the climatic chamber is sufficient. In case of failure in the climatic chamber, compliance using the cabinet provides compliance with the standard.

10.3.2.104 After the test

- *the assemblies shall show no cracks or similar damage visible to normal or corrected vision without magnification and*
- *the assemblies shall remain intact*

such that safety is not impaired.

In case of doubt, the test of 14.1.3 of Part 1 is carried out on the impacted samples to check that the declared degree of protection against access to hazardous parts is maintained. The declared degree of protection against access to hazardous parts is either the additional letter directly declared by the manufacturer according 6.7.3 of Part 1, if any, or the degree of protection against access to hazardous parts indirectly declared by the manufacturer according 6.7.1 of Part 1.

NOTE Any cracks in internal dividers which are not likely to impair electrical safety or use are ignored. Electrical safety can be impaired when the impact creates a sharp edge on a partition which can damage insulated conductors or cables (see 9.1).

10.4 Linear deflection test

Replacement:

This test is only applicable to CTS/CDS declared according to 6.101.4.

Compliance is checked by the following test.

The test is carried out on a test sample made of one trunking length or ducting length or two jointed trunking lengths or ducting lengths complying with the following conditions:

- *the length of the assembly is the maximum distance between supports (D) according to the manufacturer's instructions increased by $200 \text{ mm} + 100 \text{ mm} / 0$,*
- *unless otherwise specified in the manufacturer's instructions, the joint is positioned at mid span.*

The test sample is placed on two parallel supports which are horizontal and level, with a distance D between the supports. If no supports are part of the CTS/CDS, supports with a width of (45 ± 5) mm are used.

If no manufacturer's instructions for the orientation of the test sample are provided, the test is carried out in the most unfavourable orientation.

If no manufacturer's instructions for the fixing to the supports are provided, the test sample is not fixed to the support.

The test sample is subjected to an evenly distributed load of $1,0 \text{ g/mm}^2$ per metre length of the declared usable area for cables.

The load consists of copper cables complying with class 5 Table 3 of IEC 60228:2004 or flexible insulated conductors or cables of similar mass per meter which are placed in the sample in the following manner as shown in Figure 108.

Cables of 25 mm^2 nominal cross section are placed in the samples so that approximately 50 % of the load is achieved.

Cables of $2,5 \text{ mm}^2$ nominal cross section are placed on top of the larger cables to achieve the total load within a tolerance of $\pm 100 \text{ g}$.

To allow for settlement of the sample, a pre-load of 10 % of the load is applied and removed after approximately 5 min. The measurement apparatus is then calibrated to zero.

After 1 h ($0/+5$ min), with the load still applied, the deflection is measured at mid span at the middle of the lower surface.

The deflection shall not exceed 1 % of the distance between supports.

Access covers of CTS and cable separators shall remain adequately fixed so as to fulfil their intended function and safety shall not be impaired.

In case of doubt, the test of 14.1.3 of Part 1 is carried out on the test sample with the load still applied, to check that the declared degree of protection against access to hazardous parts is maintained. The declared degree of protection against access to hazardous parts is either the additional letter directly declared by the manufacturer according 6.7.3 of Part 1, if any, or the degree of protection against access to hazardous parts indirectly declared by the manufacturer according 6.7.1 of Part 1.

10.6 System access cover retention

Addition after the fourth paragraph:

NOTE Functional area refers, for example, to a fitting, an apparatus mounting device, a junction as shown in Figure 106.

Addition after the sixth paragraph:

Examples for arrangement are shown in Figure 107.

Additional subclause:

10.101 Compression test for CDS

CDS shall have adequate resistance to compression to ensure that insulated conductors or cables can be drawn in.

Compliance is checked by the following test:

The test is carried out on a ducting length (250 ± 5) mm long. The sample is positioned on a flat and horizontal steel support simulating the mounting surface, in its most unfavourable stable position allowed by the manufacturer's instruction.

NOTE In case of doubt over the most unfavourable position, more than one position can be tested.

A steel cube of $(50 \pm 0,5)$ mm with an edge radius of approximately 1 mm is placed with one face horizontal approximately in the middle of the length of the sample and in the most unfavourable position in the width of the sample. The distance D (Figure 109) between the horizontal support and the face of the cube in contact with the sample is measured as $D1$.

An increasing vertical compression force reaching within (30 ± 3) s the value according to 6.104 with a tolerance of ${}^+4\%$ ₀ is applied through the cube. The cube is only allowed to move in the vertical direction without rotation.

After the force has been applied for (60 ± 2) s, the distance D between the horizontal support and the face of the cube in contact with the sample is measured as $D2$ without removing the force.

The difference between $D1$ and $D2$ shall not exceed 25 % of $D1$.

The force and the cube are removed.

Within (15 ± 1) min after the removal of the cube, it is placed on the sample in its original horizontal position and the distance D between the horizontal support and the face of the cube coming into contact with the sample is measured as $D3$.

The difference between $D1$ and $D3$ shall not exceed 10 % of $D1$.

After the test, the sample shall show no cracks visible to normal or corrected vision without additional magnification.

11 Electrical properties

This clause of Part 1 is applicable.

12 Thermal properties

This clause of Part 1 is applicable.

13 Fire hazard

This clause of Part 1 is applicable.

14 External influences

This clause of Part 1 is applicable.

15 Electromagnetic compatibility

This clause of Part 1 is applicable.

Addition:

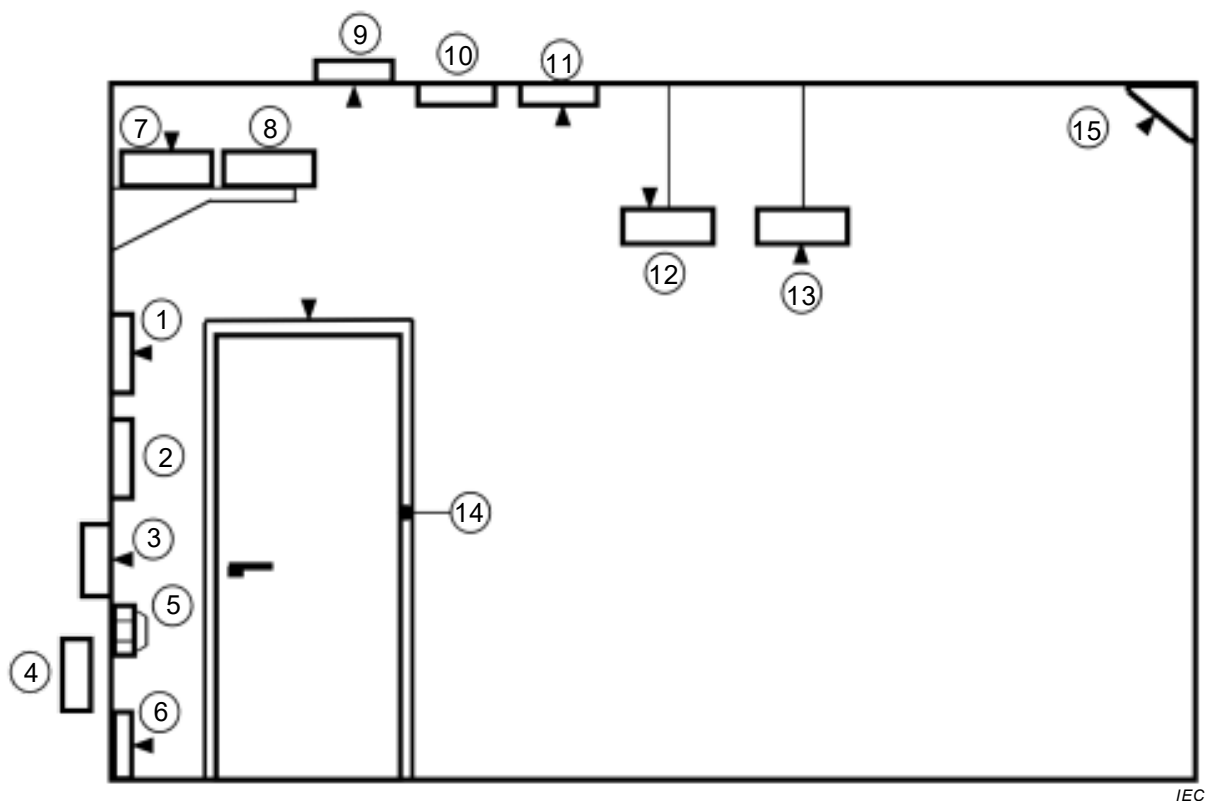

Key

▶ CTS cover position

NOTE An explanation of the numbers used in this figure is given in Annex A.

Figure 101 – Types and application of CTS/CDS for wall or ceiling installation

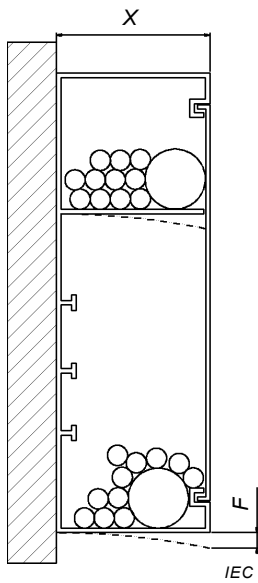

Figure 102a – Rectangular or similar cross section CTS/CDS

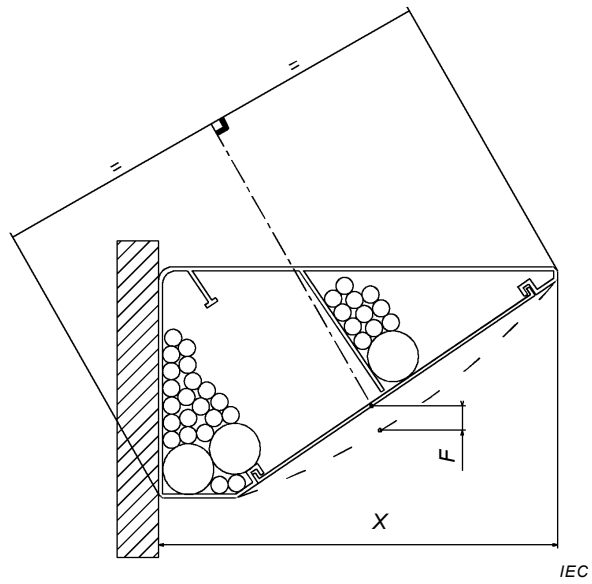

Figure 102b – Non rectangular cross section CTS/CDS

Key

- X external horizontal dimension
- F vertical deflection

Figure 102 – Arrangement for cable support test according to 10.2.2

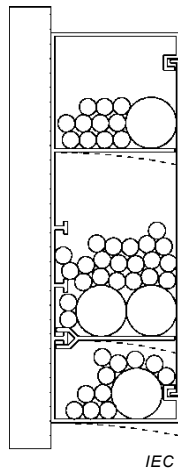

Figure 103a – Rectangular or similar cross section CTS/CDS

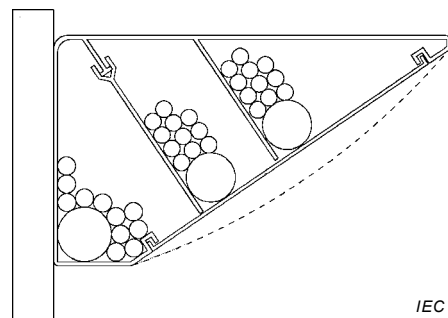

Figure 103b – Non rectangular cross section CTS/CDS

Figure 103 – Arrangement for cable support test according to 10.2.3

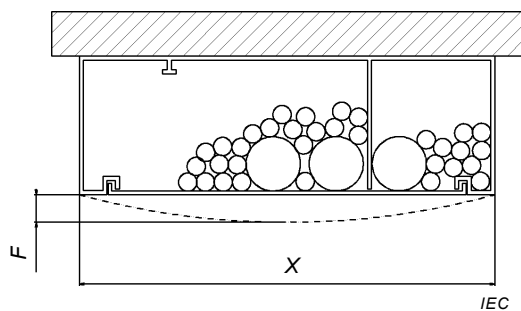

Figure 104a – Rectangular or similar cross section CTS/CDS

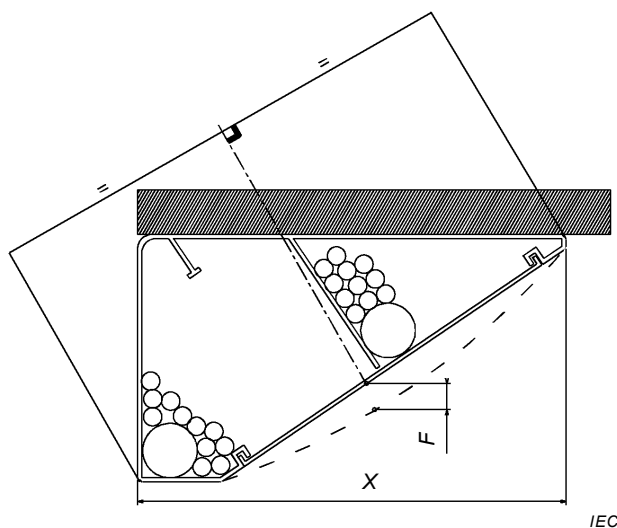

Figure 104b – Non rectangular cross section CTS/CDS

Key

X external horizontal dimension

F vertical deflection

Figure 104 – Arrangement for cable support test according to 10.2.4

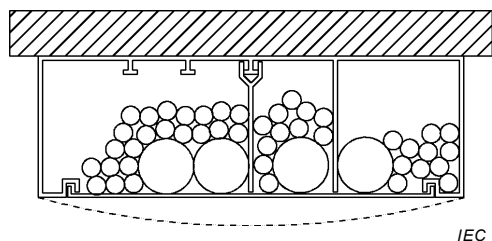

Figure 105a – Rectangular or similar cross section CTS/CDS

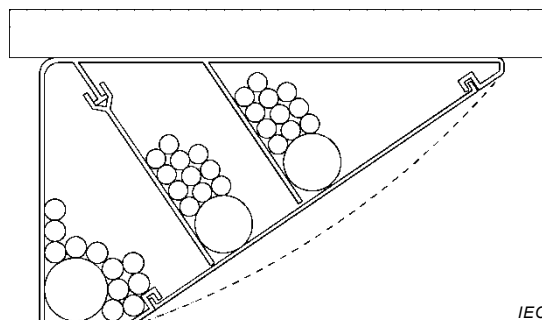

Figure 105b – Non rectangular cross section CTS/CDS

Figure 105 – Arrangement for cable support test according to 10.2.5

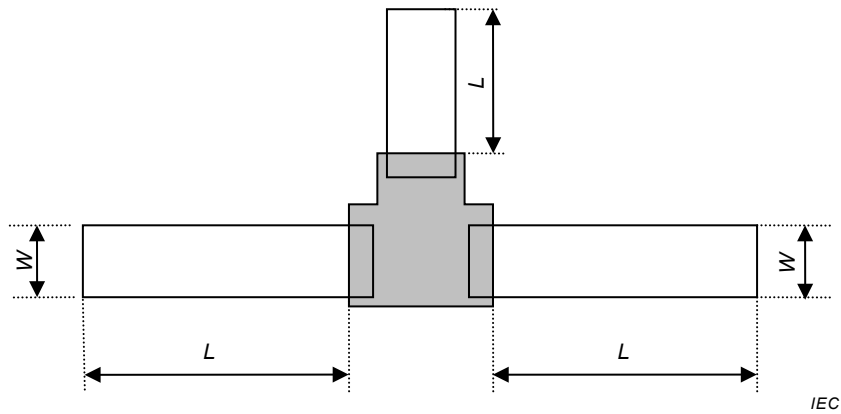

Figure 106a – Example with fitting

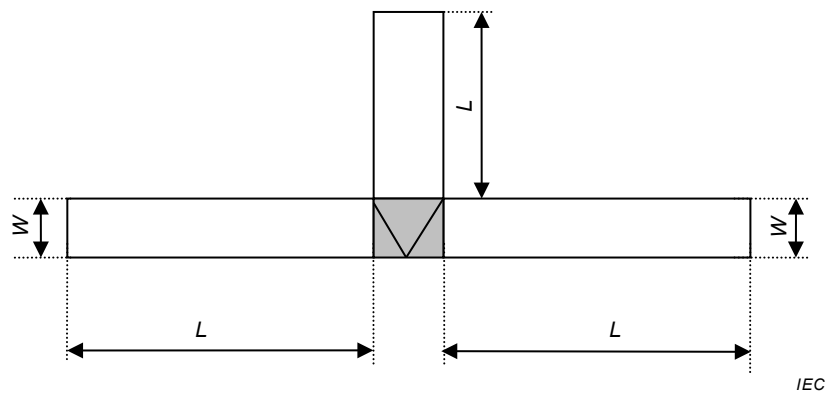

Figure 106b – Example without fitting

Key

-  Functional area associated with the function of the system (T derivation in this example)
- W width of the trunking length
- L maximum between W and 250 mm

Figure 106 – Impact test for installation and application – Principles for arrangement



IEC

With fitting

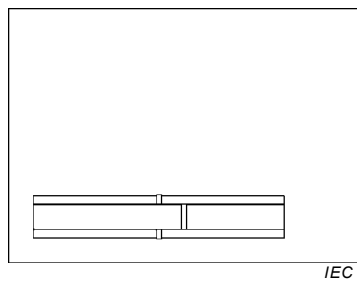
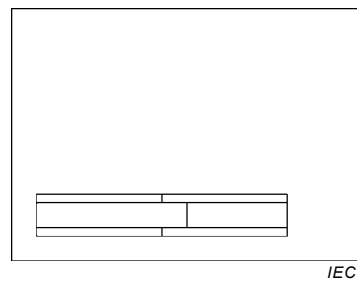

IEC

Without fitting

Figure 107a – Arrangement for connection

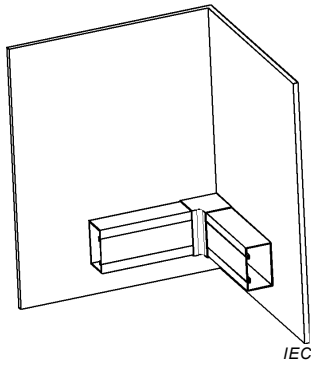

IEC

With fitting

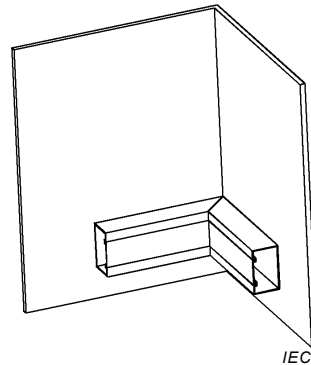

IEC

Without fitting

Figure 107b – Arrangement for internal angle

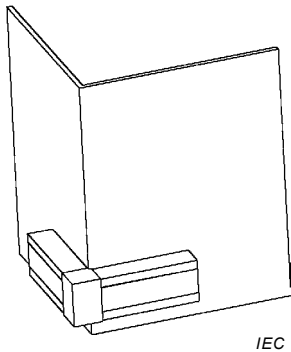

IEC

With fitting

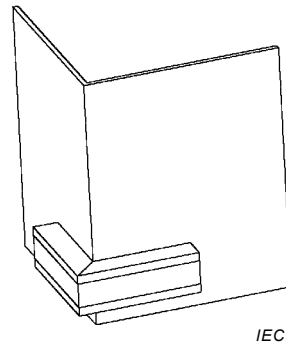

IEC

Without fitting

Figure 107c – Arrangement for external angle

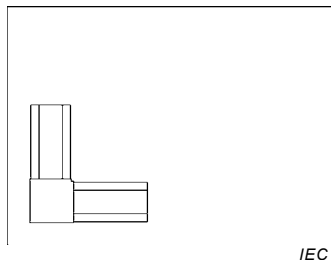

IEC

With fitting

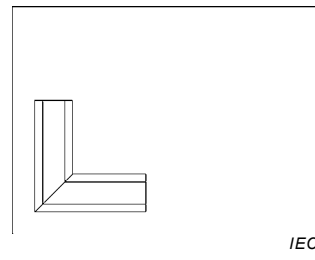

IEC

Without fitting

Figure 107d – Arrangement for flat angle

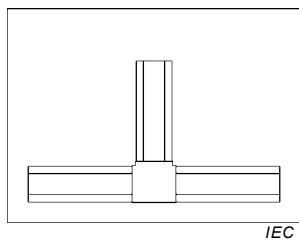

With fitting

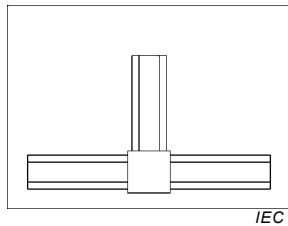

With fitting

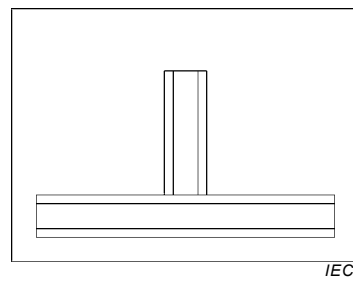

Without fitting

Figure 107e – Arrangement for diversion

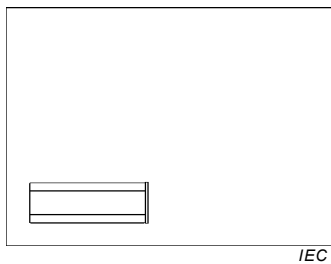
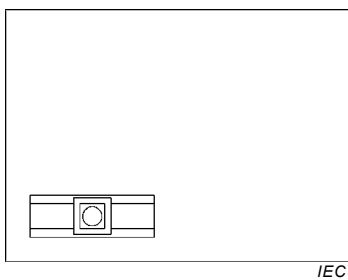
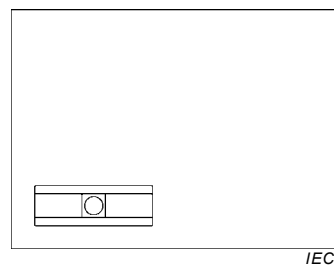

Figure 107f – Arrangement for terminating



With apparatus mounting device



With trunking length used as apparatus mounting device

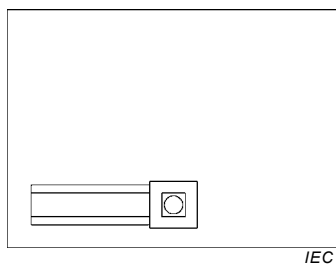

With apparatus mounting device mounted at the end of the trunking length

Figure 107g – Arrangement for apparatus mounting

Figure 107 – Impact test for installation and application – Examples for arrangement

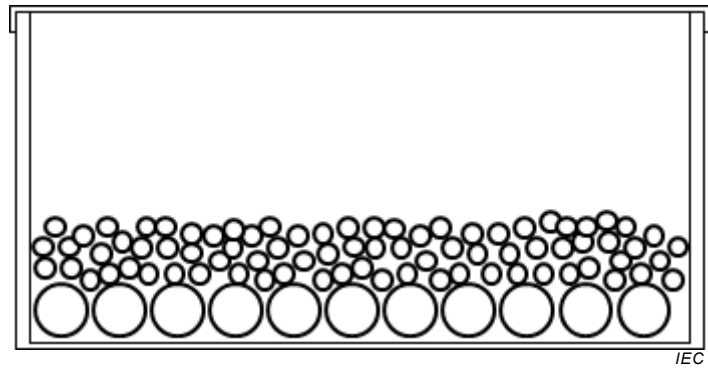
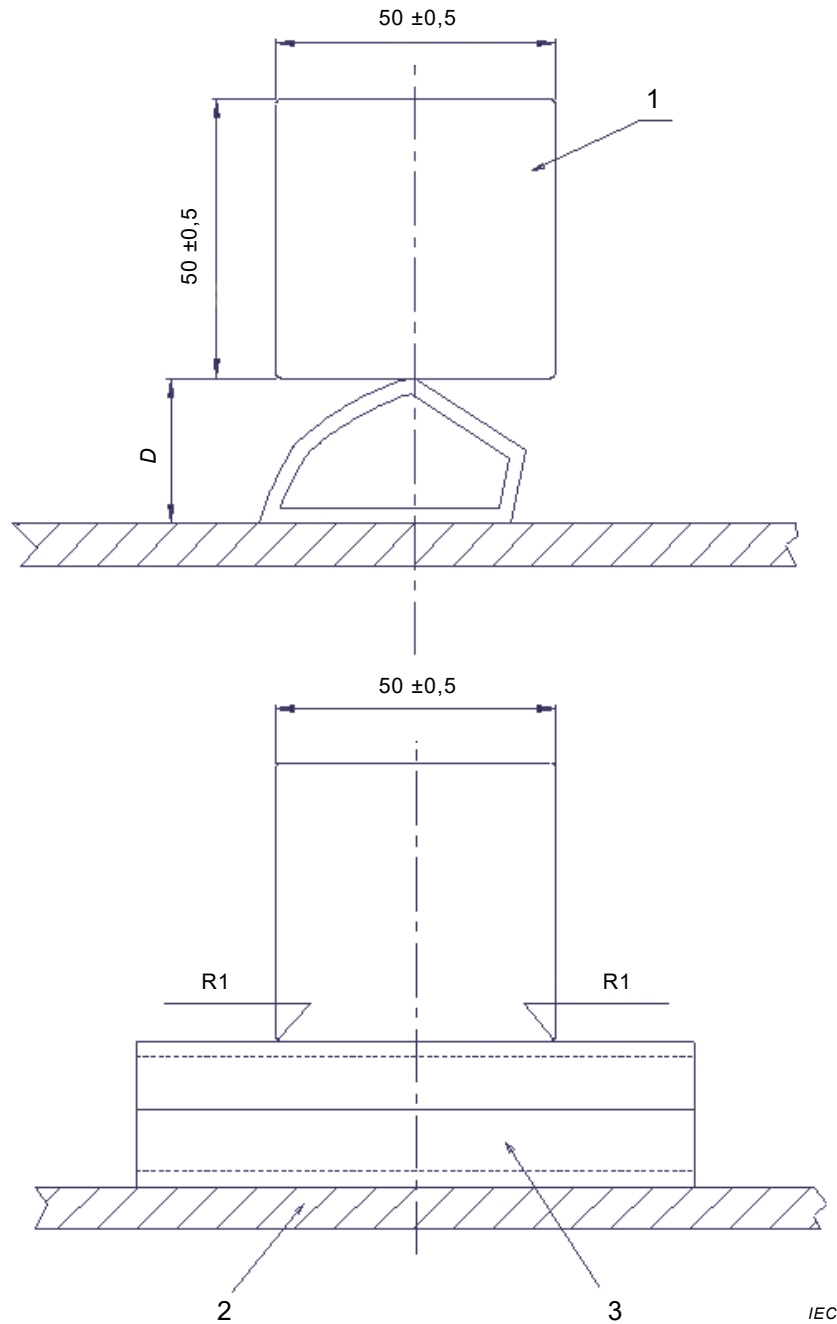

Figure 108 – Arrangement for linear deflection test

Dimensions in millimetres



Key

- 1 steel cube
- 2 flat steel support
- 3 sample
- D distance between the horizontal support and the face of the cube in contact with the sample

Figure 109 – Example of arrangement for CDS compression test

Annex A
(informative)

**Types of cable trunking systems (CTS)
and cable ducting systems (CDS)**

This annex of Part 1 is applicable, except as follows:

Table A.2 and Table A.3 are not applicable.

Annex B
(normative)

CTS/CDS IK code

This annex of Part 1 is applicable.

(Continued from second cover)

<i>International Standard</i>	<i>Corresponding Indian Standard</i>	<i>Degree of Equivalence</i>
ISO 536 : 2012 Paper and board — Determination of grammage	IS 1060 (Part 5/ Sec 5) : 2021/ISO 536 : 2019 Methods of sampling and test for paper and allied products: Part 5 Methods of test for paper and board, Section 5 Determination of grammage	Identical

For the purpose of deciding whether a particular requirement of this standard is complied with, the final value, observed or calculated expressing the result of a test, shall be rounded off in accordance with IS 2: 1960 'Rules for rounding off numerical values (*second revision*)'. The number of significant places retained in the rounded off value should be the same as that of the specified value in this standard.

Bureau of Indian Standards

BIS is a statutory institution established under the *Bureau of Indian Standards Act, 2016* to promote harmonious development of the activities of standardization, marking and quality certification of goods and attending to connected matters in the country.

Copyright

BIS has the copyright of all its publications. No part of these publications may be reproduced in any form without the prior permission in writing of BIS. This does not preclude the free use, in the course of implementing the standard, of necessary details, such as symbols and sizes, type or grade designations. Enquiries relating to copyright be addressed to the Head (Publication & Sales), BIS.

Review of Indian Standards

Amendments are issued to standards as the need arises on the basis of comments. Standards are also reviewed periodically; a standard along with amendments is reaffirmed when such review indicates that no changes are needed; if the review indicates that changes are needed, it is taken up for revision. Users of Indian Standards should ascertain that they are in possession of the latest amendments or edition by referring to the website-www.bis.gov.in or www.standardsbis.in.

This Indian Standard has been developed from Doc No.: ETD 14 (21092).

Amendments Issued Since Publication

Amend No.	Date of Issue	Text Affected

BUREAU OF INDIAN STANDARDS

Headquarters:

Manak Bhavan, 9 Bahadur Shah Zafar Marg, New Delhi 110002

Telephones: 2323 0131, 2323 3375, 2323 9402

Website: www.bis.gov.in

Regional Offices:

	Telephones
Central : 601/A, Konnectus Tower -1, 6 th Floor, DMRC Building, Bhavbhuti Marg, New Delhi 110002	{ 2323 7617
Eastern : 8 th Floor, Plot No 7/7 & 7/8, CP Block, Sector V, Salt Lake, Kolkata, West Bengal 700091	{ 2367 0012 2320 9474
Northern : Plot No. 4-A, Sector 27-B, Madhya Marg, Chandigarh 160019	{ 265 9930
Southern : C.I.T. Campus, IV Cross Road, Taramani, Chennai 600113	{ 2254 1442 2254 1216
Western : Plot No. E-9, Road No.-8, MIDC, Andheri (East), Mumbai 400093	{ 2821 8093

Branches : AHMEDABAD. BENGALURU. BHOPAL. BHUBANESHWAR. CHANDIGARH. CHENNAI. COIMBATORE. DEHRADUN. DELHI. FARIDABAD. GHAZIABAD. GUWAHATI. HIMACHAL PRADESH. HUBLI. HYDERABAD. JAIPUR. JAMMU & KASHMIR. JAMSHEDPUR. KOCHI. KOLKATA. LUCKNOW. MADURAI. MUMBAI. NAGPUR. NOIDA. PANIPAT. PATNA. PUNE. RAIPUR. RAJKOT. SURAT. VISAKHAPATNAM.