

रंग रोगन, वार्निश और संबंधित उत्पाद के  
लिए नमूने और परीक्षण की पद्धतियाँ

भाग 5 यांत्रिक परीक्षण

अनुभाग 6 अपघर्षक-कागज से ढके पहियों और घूर्णन  
परीक्षण नमूने द्वारा घर्षण के प्रतिरोध का निर्धारण

Methods of Sampling and Test for  
Paints Varnishes and Related  
Products

Part 5 Mechanical Tests

Section 6 Determination of Resistance to  
Abrasion by Abrasive-Paper Covered Wheels  
and Rotating Test Specimen

ICS 87.040

© BIS 2024

© ISO 2023



भारतीय मानक ब्यूरो

BUREAU OF INDIAN STANDARDS

मानक भवन, 9 बहादुर शाह ज़फर मार्ग, नई दिल्ली - 110002

MANAK BHAVAN, 9 BAHADUR SHAH ZAFAR MARG

NEW DELHI - 110002

[www.bis.gov.in](http://www.bis.gov.in) [www.standardsbis.in](http://www.standardsbis.in)

July 2024

Price Group 7

## NATIONAL FOREWORD

This Indian Standard (Part 5/Sec 6) which is identical to ISO 7784-1 : 2023 'Paints and varnishes — Determination of resistance to abrasion — Part 1: Method with abrasive-paper covered wheels and rotating test specimen' issued by the International Organization for Standardization (ISO) was adopted by the Bureau of Indian Standards on the recommendation of the Paints, varnishes and related products Sectional Committee and approval of the Chemical Division Council.

IS 101 'Methods of test for ready mixed paints and enamel', initially, was published as a unified standard in 1950. The standard was subsequently revised in 1961, 1964 and 1986. During the third revision, recognizing the need for clarity, the committee decided to restructure it by splitting into various parts based on type of tests. These parts included tests on liquid paints (general and physical), chemical examination, film formation, optical assessments, and mechanical tests on paint film formation. Each part was further subdivided into sections, addressing specific tests within those categories. Further, it was decided that whenever a new test method was introduced, it would be integrated into the relevant part of IS 101, ensuring that the standard remained comprehensive.

This document specifies a method for determining the resistance to abrasion of coatings, for which two loaded, freely rotatable but eccentrically arranged abrasive-paper covered wheels affect the coating of the rotating test specimen.

This Indian Standard (Part 5) is published in several sections. The other sections of this series are:

Sec 1 Hardness tests

Sec 2 Flexibility and adhesion

Sec 3 Impact resistance — Falling — Weight test, large — Area indenter

Sec 4 Print free test

Sec 5 Impact resistance — Falling — Weight test, small — Area indenter

Sec 7 Determination of resistance to abrasion by abrasive rubber wheels and rotating test specimen

Sec 8 Determination of resistance to abrasion by abrasive-paper covered wheel and linearly reciprocating test specimen

The text of ISO standard has been approved as suitable for publication as an Indian Standard without deviations. Certain conventions and terminologies are, however, not identical to those used in Indian Standards. Attention is particularly drawn to the following:

- a) Wherever the words 'International Standard' appear referring to this standard, they should be read as 'Indian Standard'; and
- b) Comma (,) has been used as a decimal marker in the International Standard, while in Indian Standards, the current practice is to use a point (.) as the decimal marker.

# Contents

Page

<b>Introduction</b> .....	<b>iv</b>
<b>1 Scope</b> .....	<b>1</b>
<b>2 Normative references</b> .....	<b>1</b>
<b>3 Terms and definitions</b> .....	<b>1</b>
<b>4 Principle</b> .....	<b>2</b>
<b>5 Apparatus and materials</b> .....	<b>2</b>
<b>6 Test specimens</b> .....	<b>4</b>
6.1 Preparation of the test specimens.....	4
6.2 Film thickness.....	4
6.3 Conditioning.....	4
<b>7 Procedure</b> .....	<b>5</b>
7.1 Agreements.....	5
7.2 Preparation of the abrasive wheels.....	5
7.3 Test conditions.....	5
7.4 Number of determinations.....	5
7.5 Test procedure.....	5
<b>8 Evaluation</b> .....	<b>6</b>
<b>9 Precision</b> .....	<b>6</b>
<b>10 Test report</b> .....	<b>6</b>
<b>Bibliography</b> .....	<b>8</b>

## Introduction

This document is one of the three parts of ISO 7784 dealing with test methods for the determination of the resistance to abrasion of coatings using abrasive wheels. The characteristics and differences of these methods are summarized in [Table 1](#).

**Table 1 — Types of method**

Standard	Abrasive wheel		Test specimen movement
	Type	Degree of freedom	
ISO 7784-1	Abrasive paper on rubber wheel	Freely rotatable	Rotation
ISO 7784-2	Abrasive rubber wheel		
ISO 7784-3	Abrasive paper on metal wheel	Rigid – with stroke-dependent rotation <sup>a</sup>	Linear reciprocation

<sup>a</sup> A mechanism rotates the abrasive wheel by a small angle after each double stroke so that a new area of the abrasive paper is effective.

It is preferable that the methods using abrasive-paper covered wheels (in this document and ISO 7784-3) are applied.

*Indian Standard*

**METHODS OF SAMPLING AND TEST FOR PAINTS VARNISHES  
AND RELATED PRODUCTS**

**PART 5 MECHANICAL TESTS**

**SECTION 6 DETERMINATION OF RESISTANCE TO ABRASION BY ABRASIVE-  
PAPER COVERED WHEELS AND ROTATING TEST SPECIMEN**

**1 Scope**

This document specifies a method for determining the resistance to abrasion of coatings, for which two loaded, freely rotatable but eccentrically arranged abrasive-paper covered wheels affect the coating of the rotating test specimen.

**2 Normative references**

The following documents are referred to in the text in such a way that some or all of their content constitutes requirements of this document. For dated references, only the edition cited applies. For undated references, the latest edition of the referenced document (including any amendments) applies.

ISO 1514, *Paints and varnishes — Standard panels for testing*

ISO 2808, *Paints and varnishes — Determination of film thickness*

ISO 3270, *Paints and varnishes and their raw materials — Temperatures and humidities for conditioning and testing*

ISO 4618, *Paints and varnishes — Terms and definitions*

ISO 48-4, *Rubber, vulcanized or thermoplastic — Determination of hardness — Part 4: Indentation hardness by durometer method (Shore hardness)*

ISO 48-5, *Rubber, vulcanized or thermoplastic — Determination of hardness — Part 5: Indentation hardness by IRHD pocket meter method*

FEPA Standard 43-1, *Grains of fused aluminium oxide, silicon carbide and other abrasive materials for coated abrasives Macrogrits P 12 to P 220<sup>1)</sup>*

FEPA Standard 43-2, *Grains of fused aluminium oxide, silicon carbide and other abrasive materials for coated abrasives Microgrits P 240 to P 5000<sup>1)</sup>*

**3 Terms and definitions**

For the purposes of this document, the terms and definitions given in ISO 4618 and the following apply.

ISO and IEC maintain terminology databases for use in standardization at the following addresses:

- ISO Online browsing platform: available at <https://www.iso.org/obp>
- IEC Electropedia: available at <https://www.electropedia.org/>

---

1) FEPA: Federation of European Producers of Abrasives.

**3.1**  
**test specimen**

specimen on which the test is to be carried out

**3.2**  
**abrasive wear**

wear, occurring due to laminar removal of coating material on the surface

**4 Principle**

Two rubber wheels, covered with agreed abrasive paper, are mounted to pivoting arms and pressed onto the coating of the rotating test specimen applying the agreed test load. The eccentric arrangement of the axes of the abrasive wheels relative to the axis of rotation causes a crosswise abrasive wear in a ring-shaped zone. The loss of mass of the coating caused by abrasive wear after the agreed number of cycles is determined.

[Figure 1](#) illustrates the test principle.

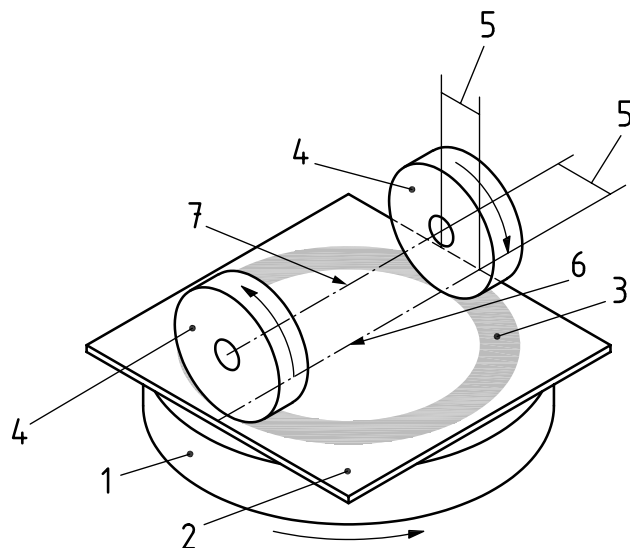

**Key**

- 1 turntable
- 2 test specimen
- 3 wear zone
- 4 abrasive wheels
- 5 offset ( $19,05 \pm 0,3$ ) mm
- 6 axis of rotation (turntable)
- 7 axis of rotation (abrasive wheel)

**Figure 1 — Principle of the abrasion test with rotating test specimen**

**5 Apparatus and materials**

**5.1 Turntable abrasion tester**, as exemplified in [Figure 2](#), with the following properties.

**5.1.1** The rotational speed of the turntable onto which the test specimen is fixed shall be  $(60 \pm 2) \text{ min}^{-1}$ . The number of cycles is pre-set on an operation counter.

5.1.2 Two arms are attached to the device, each with a mandrel, onto which the abrasive wheels (5.2) and, if necessary, the weights (5.3) are attached. Ball bearings are used for the mandrels for the abrasive wheels so they can rotate with low friction.

5.1.3 It shall be ensured that in lowered condition, the positions of the abrasive wheels relative to the axis of rotation comply with the dimensions indicated in Figure 2.

5.1.4 A suction device shall be available in order to remove abrasive dust generated during the test. The distance between the suction device and the test specimen shall be  $(3 \pm 1)$  mm.

Dimensions in millimetres

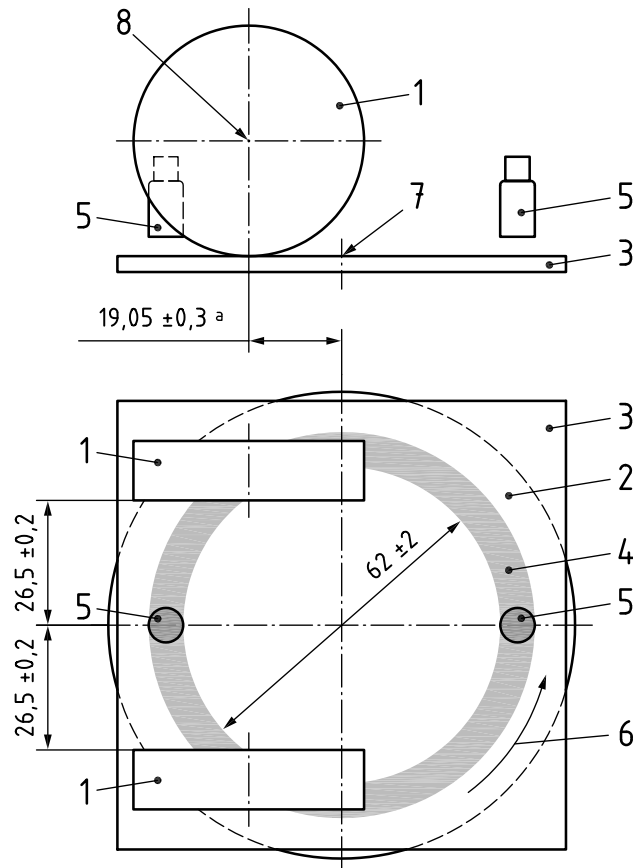

**Key**

- 1 abrasive wheels
- 2 turntable
- 3 test specimen
- 4 wear zone (about 13 mm wide)
- 5 vacuum nozzles
- 6 rotating direction
- 7 axis of rotation (turntable)
- 8 axis of rotation (abrasive wheel)
- a Offset.

**Figure 2 — Schematic diagram of the turntable abrasion tester**

**5.2 Abrasive wheel**, consisting of the rubber wheel ([5.2.1](#)) on which the abrasive paper ([5.2.2](#)) is adhered. Two abrasive wheels are required for the test.

**5.2.1 Rubber wheel**, cylindrical rubber disk equipped with an axial bore hole of  $(16,0 \pm 0,1)$  mm for attachment on the supported mandrel on the arm of the apparatus (see [5.1.2](#)). The diameter of the rubber wheel shall be  $(50,5 \pm 0,5)$  mm and the thickness  $(12,7 \pm 0,2)$  mm.

The hardness of the elastomer material shall be agreed, in Shore A in accordance with ISO 48-4, or in International Rubber Hardness Degree (IRHD) in accordance with ISO 48-5.

NOTE It is common to agree on the rubber wheel on the basis of the identification of the abrasive wheel manufacturer.

**5.2.2 Abrasive paper**, with agreed abrasive material and agreed grain size in accordance with FEPA Standard 43-1 or FEPA Standard 43-2, self-adhesive, and in strips with a width of  $(12,7 \pm 0,2)$  mm, as well as a minimum length of 160 mm.

If no self-adhesive abrasive paper is available, regular abrasive paper may be used together with double-sided adhesive tape.

In case the strips of abrasive paper are cut at an angle ( $45^\circ$ ) prior to adhering (see [Figure 3](#)), a minimum length of 173 mm is required.

NOTE It is common to agree on the abrasive paper on the basis of the identification of the abrasive wheel manufacturer.

**5.3 Weights**, to increase the test load up to about 10 N by attaching to each arm (see [5.1.2](#)).

NOTE For a common apparatus, the minimum test load which is exerted solely by the abrasive wheel and the arms without additional weights is 2,5 N and with the weights, the test load values 4,9 N and 9,8 N are additionally available for each abrasive wheel. Test load references are per each arm and do not include the mass of the abrasive wheel.

**5.4 Balance**, with a maximum permissible error of 0,1 mg.

## 6 Test specimens

### 6.1 Preparation of the test specimens

The test specimens shall be plane, have the minimum dimensions of 100 mm × 100 mm, and be prepared, coated, and dried/hardened in accordance with ISO 1514.

For the mentioned dimensions of the test specimen, the minimum distance between wear zone and edge of the test specimen shall be about 7 mm (see [Figure 2](#)).

For a common apparatus, the test specimen is fixed on the turntable by means of an axial screw. For this, the test specimen shall have a bore hole in the centre.

### 6.2 Film thickness

Determine the dry film thickness of the coating, in micrometres, in accordance with one of the methods specified in ISO 2808.

### 6.3 Conditioning

Prior to testing, condition the coated test specimen at a temperature of  $(23 \pm 2)$  °C and a relative humidity of  $(50 \pm 5)$  % in accordance with ISO 3270, if not agreed otherwise, for at least 16 h.



## 7 Procedure

### 7.1 Agreements

For the test procedure, the following shall be agreed:

- the type of abrasive wheel, i.e. the hardness of the rubber wheel (5.2.1), as well as the material and the grain size of the abrasive paper (5.2.2);
- the test load for each abrasive wheel, in newtons;
- the number of cycles, observing 7.5.4.

### 7.2 Preparation of the abrasive wheels

Condition the strips of abrasive paper (5.2.2) [and, if necessary, the adhesive tape (see 5.2.2, NOTE)] in accordance with 6.3 and adhere them to the circumference of the rubber wheels (5.2.1) without any gaps or overlapping. Subsequently, store the prepared abrasive wheels under the climatic conditions in accordance with 6.3 until using them during the test.

It is recommended that the strips of abrasive paper be cut at an angle of 45° and joined respectively when adhering (see Figure 3).

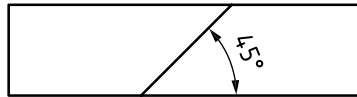

**Figure 3 — Recommended method for joining the ends of the abrasive paper strip**

The abrasive paper shall be replaced for each test (single determination in accordance with 7.5). See also 7.5.4.

### 7.3 Test conditions

Carry out the test at a temperature of  $(23 \pm 2)$  °C and measure the relative humidity during the test and state it in the test report.

Carry out the test as quick as possible, however, not later than 30 min after the conditioning phase.

### 7.4 Number of determinations

Carry out the determination in triplicate on three separate test specimens.

### 7.5 Test procedure

**7.5.1** Weigh the test specimen to 0,1 mg using the balance (5.4) and mount it to the turntable of the apparatus.

**7.5.2** Attach the abrasive wheels, which have been prepared in accordance with 7.2, to the arms of the apparatus and lower onto the coating.

**7.5.3** Load the abrasive wheels, if necessary, in accordance with the agreed test load using an additional weight on each arm (5.3).

**7.5.4** Set the counter to the agreed number of cycles (rotations), turn on the suction device, and start the rotation of the turntable.

The abrasive wheels can become very smooth when taking up coating material so that they lose their abrasive effect and, consequently, stop rotating (and begin to block). In this case, the test shall be interrupted and the abrasive wheels shall be covered with new abrasive paper in accordance with [7.2](#). In order to avoid blocking, it can be appropriate to agree on a lower number of cycles.

In case of wear through of the coating down to the substrate or down to a subjacent coating, a lower number of cycles shall be agreed.

**7.5.5** Clean the test specimen using a lint-free cloth and weigh to the nearest 0,1 mg.

**7.5.6** Repeat working steps [7.5.1](#) to [7.5.5](#) with two additional test specimens.

## **8 Evaluation**

**8.1** For each of the three test specimens, calculate the loss in mass of the coating as difference of the masses of the test specimen in accordance with [7.5.1](#) and [7.5.5](#), in milligrams. Calculate the mean value of the losses in mass of the three test specimens.

**8.2** As test result, report the mean value of the losses in mass in accordance with [8.1](#) and the three single values to the nearest 1 mg.

## **9 Precision**

No relevant precision data are currently available.

## **10 Test report**

The test report shall include at least the following information:

- a) all details necessary to identify and characterize the test specimen, i.e. details regarding
  - 1) coating (manufacturer, product identification, batch number, application method, drying/hardening/ageing conditions, etc.), and
  - 2) substrate (material, thickness, pre-treatment, etc.);
- b) the film thickness, in micrometres, in accordance with [6.2](#);
- c) a reference to this document, i.e. ISO 7784-1:2023;
- d) the agreed type of abrasive wheel in accordance with [5.2](#);
- e) the agreed test load for each abrasive wheel, in newtons;
- f) the agreed number of cycles;
- g) the relative humidity during testing;
- h) the test result in accordance with [8.2](#): the mean loss of mass and the single values, in milligrams;
- i) any deviation from the test method specified;
- j) any unusual features (anomalies) observed during the test;
- k) the name of the operator and the testing laboratory;

l) the date of the test.

## Bibliography

- [1] ISO 9352, *Plastics — Determination of resistance to wear by abrasive wheels*
- [2] ASTM D4060, *Standard Test Method for Abrasion Resistance of Organic Coatings by the Taber Abraser*
- [3] DIN 53754, *Testing of plastics — Determination of abrasion, abrasive disk method*
- [4] EN 13523-16, *Coil coated metals — Test methods — Part 16: Resistance to abrasion*





(Continued from second cover)

In this adopted standard, the reference appears to certain International Standards for which Indian Standards also exist. The corresponding Indian Standards, which are to be substituted in their respective places, are listed below along with their degree of equivalence for the editions indicated:

<i>International Standards</i>	<i>Corresponding Indian Standard</i>	<i>Degree of Equivalence</i>
ISO 48-4 Rubber vulcanized or thermoplastic — Determination of hardness — Part 4: Indentation hardness by durometer method (shore hardness)	IS 3400 (Part 2/Sec 4) : 2022 Methods of test for rubber vulcanized or thermoplastic: Part 2 Determination of hardness, Section 4 Indentation hardness by durometer method (shore hardness) ( <i>second revision</i> )	Identical
ISO 48-5 Rubber vulcanized or thermoplastic — Determination of hardness — Part 5: Indentation hardness by IRHD pocket meter method	IS 3400 (Part 2/Sec 5) : 2022 Methods of test for rubber vulcanized or thermoplastic: Part 2 Determination of hardness Section 5 Indentation hardness By IRHD pocket meter method ( <i>second revision</i> ).	Identical

The Committee has reviewed the provisions of the following International Standards/ documents referred in this adopted standard and has decided that they are acceptable for use in conjunction with this Standard:

<i>International Standards</i>	<i>Title</i>
ISO 1514 : 2016	Paints and varnishes — Standard panels for testing
ISO 2808 : 2019	Paints and varnishes — Determination of film thickness
ISO 3270 : 1984	Paints and varnishes and their raw materials — Temperatures and humidities for conditioning and testing
ISO 4618 : 2014	Paints and varnishes — Terms and definitions
FEPA-Standard 43-1 : 2006	Grains of fused aluminium oxide silicon carbide and other abrasive materials for coated abrasives Macrogrits P 12 to P 220
FEPA Standard 43-2 : 2017	Grains of fused aluminium oxide silicon carbide and other abrasive materials for coated abrasives Microgrits P 240 to P 5000

In this adopted standard, reference appears to certain International Standards/documents where the standard atmospheric conditions to be observed are stipulated which are not applicable to tropical/subtropical countries. The applicable standard atmospheric conditions for Indian conditions are  $(27 \pm 2) ^\circ\text{C}$  and  $(65 \pm 5)$  percent relative humidity and shall be observed while using this standard.

In reporting the result of a test or analysis made in accordance with this standard, if the final value, observed or calculated, is to be rounded off, it shall be done in accordance with IS 2 : 2022 'Rules for rounding off numerical values (*second revision*)'.

## Bureau of Indian Standards

BIS is a statutory institution established under the *Bureau of Indian Standards Act, 2016* to promote harmonious development of the activities of standardization, marking and quality certification of goods and attending to connected matters in the country.

### Copyright

BIS has the copyright of all its publications. No part of these publications may be reproduced in any form without the prior permission in writing of BIS. This does not preclude the free use, in the course of implementing the standard, of necessary details, such as symbols and sizes, type or grade designations. Enquiries relating to copyright be addressed to the Head (Publication & Sales), BIS.

### Review of Indian Standards

Amendments are issued to standards as the need arises on the basis of comments. Standards are also reviewed periodically; a standard along with amendments is reaffirmed when such review indicates that no changes are needed; if the review indicates that changes are needed, it is taken up for revision. Users of Indian Standards should ascertain that they are in possession of the latest amendments or edition by referring to the website-[www.bis.gov.in](http://www.bis.gov.in) or [www.standardsbis.in](http://www.standardsbis.in).

This Indian Standard has been developed from Doc No.: CHD 20 (23876).

### Amendments Issued Since Publication

Amend No.	Date of Issue	Text Affected

## BUREAU OF INDIAN STANDARDS

### Headquarters:

Manak Bhavan, 9 Bahadur Shah Zafar Marg, New Delhi 110002

Telephones: 2323 0131, 2323 3375, 2323 9402

Website: [www.bis.gov.in](http://www.bis.gov.in)

### Regional Offices:

	Telephones
Central : 601/A, Konnectus Tower -1, 6 <sup>th</sup> Floor, DMRC Building, Bhavbhuti Marg, New Delhi 110002	{ 2323 7617
Eastern : 8 <sup>th</sup> Floor, Plot No 7/7 & 7/8, CP Block, Sector V, Salt Lake, Kolkata, West Bengal 700091	{ 2367 0012 2320 9474
Northern : Plot No. 4-A, Sector 27-B, Madhya Marg, Chandigarh 160019	{ 265 9930
Southern : C.I.T. Campus, IV Cross Road, Taramani, Chennai 600113	{ 2254 1442 2254 1216
Western : Manakalya, 4 <sup>th</sup> Floor, NTH Complex (W Sector), F-10, MIDC, Andheri (East), Mumbai 400093	{ 283 25838

**Branches :** AHMEDABAD, BENGALURU, BHOPAL, BHUBANESHWAR, CHANDIGARH, CHENNAI, COIMBATORE, DEHRADUN, DELHI, FARIDABAD, GHAZIABAD, GUWAHATI, HARYANA (CHANDIGARH), HUBLI, HYDERABAD, JAIPUR, JAMMU, JAMSHEDPUR, KOCHI, KOLKATA, LUCKNOW, MADURAI, MUMBAI, NAGPUR, NOIDA, PARWANOO, PATNA, PUNE, RAIPUR, RAJKOT, SURAT, VIJAYAWADA.