

मृदु इस्पात की पानी की पाइपलाइनों के
लिए कोल्ड एप्लाइड
(पॉलीइथीलीन/पॉलीओलेफिन) पट्टिका
लेपन — विशिष्टि

**Cold Applied (Polyethylene/
Polyolefin) Tape Coating for Mild
Steel Water Pipelines — Specification**

ICS 25.220.01

© BIS 2024



भारतीय मानक ब्यूरो
BUREAU OF INDIAN STANDARDS
मानक भवन, 9 बहादुर शाह ज़फर मार्ग, नई दिल्ली - 110002
MANAK BHAVAN, 9 BAHADUR SHAH ZAFAR MARG
NEW DELHI - 110002
www.bis.gov.in www.standardsbis.in

November 2024

Price Group 10

FOREWORD

This Indian Standard was adopted by the Bureau of Indian Standards, after the draft finalized by the Corrosion Protection and Finishes Sectional Committee had been approved by the Metallurgical Engineering Division Council.

Cold applied polyethylene/polyolefin tape is an effective corrosion protection solution for mild steel water pipelines. This tape is designed for ease of application, requiring no heat or specialized equipment, which simplifies installation and maintenance. Its robust polyethylene/polyolefin composition provides a durable barrier against moisture, chemicals, and physical damage, ensuring long-term protection and extending the lifespan of pipelines. Ideal for various environmental conditions, this tape adheres securely to the pipe surface, preventing corrosion and preserving the integrity of water distribution systems.

This standard defines cold applied tape coating systems in terms of its performance or its ability to provide long terms corrosion protection. This standard is intended for use in exterior coating of steel pipelines for underground or underwater installation under normal conditions. This standard is based on best- known experience, but is not intended for unqualified use under all conditions. Cold applied tape coating systems usage for any installation must be reviewed by the purchaser.

If an extended period of aboveground storage of coated pipe is anticipated, the ability of coating to resist degradation by UV light and other atmospheric and environmental conditions should be considered.

The composition of the Committee responsible for the formulation of this standard is given in [Annex B](#).

For the purpose of deciding whether a particular requirement of this standard is complied with, the final value, observed or calculated, expressing the result of a test or analysis, shall be rounded off in accordance with IS 2 : 2022 'Rules for rounding off numerical values (*second revision*)'. The number of significant places retained in the rounded off value should be the same as that of the specified value in this standard.

Indian Standard

COLD APPLIED (POLYETHYLENE/POLYOLEFIN) TAPE COATING FOR MILD STEEL WATER PIPELINES — SPECIFICATION

1 SCOPE

This standard specifies the requirements for material and application of plant applied as well as hand wrapped polyethylene/polyolefin tape coating for external corrosion protection of MS water pipeline. Normally prefabricated polyethylene/polyolefin tapes are applied as a three-layer system consisting of:

- a) liquid adhesive;
- b) corrosion preventive tape; and
- c) mechanical protective tape.

2 REFERENCES

The standards listed in [Annex A](#) contain provisions, which through references in this text constitute provisions of this standard. At the time of publication, the editions indicated were valid. All standards are subject to revision and parties to agreements based on this standard are encouraged to investigate the possibility of applying the most recent edition of these standards.

3 MATERIAL

The total coating system shall consist of following components:

- a) Primer;
- b) Inner layer tape;
- c) Intermediate layer tape (optional for Type A coating system); and
- d) Outer layer tape.

3.1 Primer

The primer consists of butyl rubber-based adhesive which shall conform to the properties specified in [Table 1](#).

3.2 Inner Layer Tape

Inner layer tape shall have single side adhesive layer and shall have properties given in [Table 2](#). The inner layer tape shall be applied after the liquid adhesive/primer and before application of the intermediate or outer layer tape. The purpose of inner layer tape is to provide corrosion protection.

3.3 Intermediate Layer Tape and Outer Layer Tape

The intermediate layer tape and outer layer tape shall have single side adhesive layer and shall be compatible with the inner layer tape. The intermediate layer tape provides additional mechanical protection. The outer layer tape provides mechanical and outdoor weathering protection to the coating system and also overall corrosion protection to the system. Physical properties of intermediate and outer layer tape shall conform to values stated in [Table 3](#). The outer layer must contain UV stabilizers to provide UV stability.

3.4 Total Coating System

Properties of total coating system shall conform to the values given in [Table 4](#).

4 DIMENSIONS

4.1 Thickness of Coating System

There are two types of coating systems based on specified outside diameter of the pipe. Thickness of coating system shall conform to values specified in [Table 5](#).

4.2 Width

The recommended width of tapes used in coating system are specified in [Table 6](#). Tape shall be supplied in roll form wound on hollow core.

5 APPLICATION OF THE COATING SYSTEM

5.1 Initial Preparation

5.1.1 Mud, mill scale, wax, coal tar, asphalt, oil, grease, soluble salt or any other foreign material shall be removed prior to blast cleaning.

5.1.2 After removing foreign materials from the surface, the pipe shall be cleaned by blasting with sand, grit or shot to achieve surface cleanliness up to a level of Sa 2½ as per IS 9954 (near white metal). The blasted surface profile shall be 50 microns to 75 microns and it shall be measured by replica tape as per ISO 8503-5. The abrasive used shall be maintained clean, dry and free from contaminants not to contaminate the substrate.

Table 1 Properties of Primer(Clause [3.1](#))

SI No.	Property	Minimum	Maximum	Method of Test, Ref to
(1)	(2)	(3)	(4)	(5)
i)	Color	Black	–	Visual
ii)	Weight			
	a) Flammable	0.70 kg/l	0.95 kg/l	6.2
	b) Non-flammable	1.2 kg/l	1.40 kg/l	6.2
iii)	Flash point			
	a) Flammable	- 17 °C	–	6.3
	b) Non-flammable	Not applicable	–	6.3

Table 2 Property Requirements of Inner Layer Tape(Clauses [3.2](#), [6.4](#) and [8.2](#))

SI No.	Property	Minimum	Maximum	Method of Test, Ref to
(1)	(2)	(3)	(4)	(5)
i)	Width deviation	- 5 %	+ 5 %	6.4
ii)	Nominal thickness	480 microns	–	6.5
iii)	Ratio of adhesive to total inner layer tape thickness ' t_{inner} '	40 % of total t_{inner}	60 % of total t_{inner}	6.6
iv)	Tensile strength	3.5 N/mm width	–	6.8
v)	Elongation	100 %	–	6.8
vi)	Peel force or adhesion to prepared steel	2.2 N/mm width	–	6.9
vii)	Water absorption (24 h)	–	0.2 % by weight	6.10
viii)	Water vapour transmission	0	0.10 g/h.m ²	6.11
ix)	Dielectric strength	17 kV/mm	–	6.12
x)	Non-polyolefin material % by wt	1 %	3.5 %	6.13
xi)	Holiday test voltage	6 000 V/single layer	–	6.14

NOTE — The total inner layer tape thickness (t_{inner}) comprises thickness of adhesive layer and a polyethylene/polyolefin layer. The property ratio of adhesive to total inner layer tape thickness is to check the ratio of adhesive to the total inner layer thickness, that is checking the percentage of adhesive as thickness against the total inner layer.

Table 3 Property Requirements of Intermediate Layer Tape and Outer Layer Tape*(Clauses [3.3](#), [6.4](#), [6.9.6](#) and [8.2](#))*

SI No.	Property	Minimum	Maximum	Method of Test, Ref to
(1)	(2)	(3)	(4)	(5)
i)	Width deviation	- 5 %	+ 5 %	6.4
ii)	Nominal thickness	722 microns	–	6.5
iii)	Tensile strength	7 N/mm width	–	6.8
iv)	Elongation	100 %	–	6.8
v)	Peel force or adhesion to inner layer	0.2 N/mm width	–	6.9
vi)	Non-polyolefin material % by wt	3 %	7 %	6.13
vii)	UV resistance (outer tape only)	No visual cracks	–	6.17

Table 4 Property Requirements of Total Coating System*(Clause [3.4](#), [8.2](#) and [6.16.2](#))*

SI No.	Property	Minimum	Maximum	Method of Test, Ref to
(1)	(2)	(3)	(4)	(5)
i)	Thickness			
	a) Type A	1 202 microns	=	6.5
	b) Type B	1 924 microns		
ii)	Holiday test voltage			
	a) Type A	12 000 V	–	6.14
	b) Type B	12 000 V		
iii)	Impact resistance			
	a) Type A	2.8 Nm	–	6.15
	b) Type B	2.8 Nm		
iv)	Penetration resistance			
	a) Type A	–	25 % with no holiday	6.16
	b) Type B		25 % with no holiday	
v)	Cathodic disbondment	–	12 mm	6.18

Table 5 Thickness of Coating System

(Clause 4.1)

SI No.	Type of Coating System	Specified Outside Diameter of Pipe	Coating System	Minimum Total Coating Thickness, (mm)
(1)	(2)	(3)	(4)	(5)
i)	Type A	Up to 1 400 mm	Primer, 1 layer of inner layer tape and 1 layer of outer layer tape	1.17
ii)	Type B	1 400 mm and more	Primer, 1 layer of inner layer tape, 1 layer of intermediate layer tape and 1 layer of outer layer tape	1.85

NOTES

1 For extremely corrosive soil, Type B coating may be preferred even for pipe diameter less than 1 400 mm.

2 Coating system laid under severe physical conditions may be protected with an additional layer of rock shield material:

- a) Rock shield is a polymer roll or pad wrap that is used to wrap around the pipeline to protect the pipe coating surface from damage during and after backfill. It should have good impact resistance and compressive strength. It shall not interfere with the cathodic protection systems of pipeline.

Table 6 Width of Tape

(Clause 4.2)

SI No.	Nominal Pipe Diameter, (mm)	Recommended Width of Tape, (mm)
(1)	(2)	(3)
i)	100 to 150	100 ± 5
ii)	151 to 300	200 ± 5
iii)	301 and above	300 ± 5

5.1.3 Blast cleaned pipe surfaces shall be free from high humidity, rainfall or surface moisture. If pipe is flash rusted the same shall be re-blasted. To ensure a dry pipe surface at the time of liquid adhesive application, the minimum steel substrate temperature shall be 7 °C and at least 5 °C above dew point.

5.1.4 Only solvents that do not leave a residue shall be used. Preheating to remove oil, grease, and mill scale may be used, provided that all pipe is preheated in a uniform manner to avoid distortion.

5.1.5 Weld Seam

Before applying the inner layer tape, the weld seams shall be ground flush for a distance of 450 mm along the length on both sides. These weld seams shall be

coated with liquid adhesive and then covered with a strip of tape. Weld seam cover tape shall be compatible with liquid adhesive. For more than 1 500 mm pipe diameter stripping tape is required. The alternative is to grind the weld seam for the entire length of the pipe.

5.2 Application of Primer

The primer (liquid adhesive) shall be thoroughly mixed before application on pipe for 2 h to 3 h before usage. The liquid primer shall be free from floods, runs, sags, drips or bare spots and shall be applied by spray, roller, or by brushes in a manner so that it makes a uniform thin film. Before application of inner layer tape, the primer shall be touch dry.

5.3 Application of Inner Layer Tape

The inner layer tape shall be applied spirally on dry to touch dry primer by constant tension equipment. Minimum overlap shall be 25 mm or more. The overlap shall be smooth and shall maintain continuity of inner layer coating. When splicing the rolls of tape from one roll to the next, the minimum overlap shall be 150 mm. The inner layer tape should be applied at a minimum roll temperature of 21 °C. Follow the tape manufacturers guidelines for recommended temperatures for rolls above 21 °C.

5.4 Application of Intermediate Layer Tape and Outer Layer Tape

Intermediate layer tape and outer layer tape shall be applied by constant tension coating equipment. The overlap of inner layer tape, intermediate layer tape and outer layer tape shall not coincide with each other. Minimum overlap shall be 25 mm or more. When splicing the rolls of tape from one roll to the next, the minimum overlap shall be 150 mm. The intermediate and outer layer tape shall be applied at a minimum roll temperature of 21 °C. Follow the tape manufacturers guidelines for recommended temperatures for rolls above 21 °C.

5.5 Coating Repair in Plant and Field

5.5.1 All coated and wrapped pipes shall be tested with an approved high voltage holiday detector preferably equipped with an audio-visual signaling device to indicate any faults, holes, breaks or conductive particles in the protective coating. Holiday area is repaired by the following steps:

- a) Remove outer and inner layers from the damaged area;
- b) Apply primer;
- c) Apply inner layer tape by wrapping around the pipe around the damaged area; and
- d) Apply a layer of outer layer tape by wrapping around the pipe over the inner layer tape.

5.5.2 Minimum lap of inner layer tape at the damaged area is 100 mm all around. The area coated with inner layer tape shall then be tested for holidays. If holidays are not found, the repaired area shall be covered with the outer layer tape with a minimum overlap of 100 mm beyond the inner tape patch.

6 TESTS

The physical and electrical properties of the tape vary with temperature and moisture content. In order that, the test methods yield consistent and

reproducible results, control the temperature and moisture content of the sample or specimen as specified in individual tests as described in this standard.

6.1 Conditioning

Condition all the rolls of tape for a minimum of 24 h to a temperature of 23 °C ± 5 °C before taking samples.

Condition all the test specimens for a period of 1 h in a controlled atmosphere at 23 °C ± 5 °C and (50 ± 10) percent relative humidity prior to testing.

Unless otherwise specified, testing shall be conducted at 23 °C ± 5 °C and (50 ± 10) percent relative humidity.

6.2 Weight of the Adhesive Primer

Weight of the primer shall be measured in kg/l as per IS 101 (Part 1/Sec 7).

6.3 Flash Point of Adhesive Primer

Flash point of primer shall be measured as per IS 101 (Part 1/Sec 6).

6.4 Width of Tape

A test specimen of inner layer tape, intermediate layer tape and outer layer tape of length at least 0.9 m long shall be removed from each of the 3 randomly selected rolls from each lot. The width of the specimen shall be measured at several points along length of the sample using a standard calibrated scale having least count of 1 mm. The width deviation shall not exceed the limits provided in [Table 2](#) and [Table 3](#).

6.5 Thickness of Tape

A dead weight thickness gauge which consist of a presser foot with diameter of 6 mm, anvil with diameter of 6 mm to 50 mm and a weighted presser foot so that the total pressure applied to a specimen is equal to 50 kPa ± 5 kPa.

The gauge shall be calibrated for the actual load exerted by the presser foot by means of any device so arranged as to measure the total vertical force exerted by the presser foot at the several gauge readings or presser foot levels selected for calibration. The presser foot shall be brought to each calibration level from a higher one.

Any commercial instrument that, including a hand-held micrometer, which creates the total pressure

applied to a specimen equal to 50 kPa ± 5 kPa is permissible for the thickness measurement.

The least count of the tape thickness measuring instrument shall be 1 micron.

6.6 Ratio of Adhesive to Inner Layer Tape Thickness

Ratio of adhesive to inner layer tape thickness can be measured at the time of manufacturing of inner layer tape (see 6.6.1) and also after the inner layer tape is manufactured (see 6.6.2).

6.6.1 During the manufacturing of the inner layer tape, it can be done by measuring thicknesses of polyethylene/polyolefin tape (t_{PE}) and total inner layer tape (t_{inner}) separately as per 6.5.

Percent ratio of adhesive to total inner layer tape

$$= \frac{t_{inner} - t_{PE}}{t_{inner}} \times 100$$

where

t_{inner} = thickness of total inner layer comprising of adhesive and polyethylene/polyolefin layer; and

t_{PE} = thickness of polyethylene/polyolefin layer only.

6.6.2 After the inner layer tape is ready, measure the total inner layer tape thickness (t_{inner}), remove the adhesive layer from the tape by dissolving the adhesive layer completely into suitable solvent (generally petroleum material like petrol or diesel), clean the polyethylene/polyolefin tape and then measure the thickness of polyethylene/polyolefin tape (t_{PE}). Calculate the ratio as per formula given in 6.6.1.

6.7 Length of Tape in a Roll

The number of linear metres of tape wound into a roll as measured in accordance with the test method mentioned below. Measurement of the length of tape in a roll is necessary to ensure receiving correct quantities.

6.7.1 Apparatus

Balance capable of weighing with an accuracy of 1 percent of the weight.

6.7.2 Test Specimen

Test specimen of 1 metre long along the length of the tape should be removed from full roll of tape.

6.7.3 Procedure

Weigh each roll with accuracy of 1 percent. Remove a test specimen as mentioned in 6.7.2. After conditioning the test specimen for 1 h, measure the relaxed length of the specimen and weigh with 1 percent accuracy. Weigh the core of the roll after application to 1 percent accuracy.

Calculate the metres per roll as follows:

Metres per roll (m)

$$\frac{(\text{weight of roll in kg} - \text{weight of the core in kg}) \times \text{Length of test specimen (m)}}{\text{Weight of test specimen (kg)}}$$

6.8 Tensile Strength and Elongation

6.8.1 Test Specimens

Use test specimens that are the same width of the tape as received if possible. If it is necessary to trim the test specimens due to the machine or jaw width limitations, take extreme care since hand trimming has the potential to materially affect the test results. Cut the test specimen with a sharp razor blade or scissors along the length of tape, unless otherwise specified. Cut the length of test specimen to the nearest 0.1 m. Condition the specimen as per 6.1.

6.8.2 Testing Machine

The tensile testing machine should be a constant rate of extension type and should be capable for recording tensile load and amount of separation of grips. The apparatus must be capable of providing smooth, uniform jaw movement during testing and the rate adjustable in increments necessary to produce strain rates that are specified for the materials under test.

6.8.3 Extension Indicator

A suitable instrument for determining the distance between two fixed points located within the gauge length of the test specimen at any time during the test. It is desirable, but not essential, that this instrument automatically record this distance as a function of the load on the test specimen, or of the elapsed time from the start of the test, or both. If only the latter is obtained, also take load-time data. Generally, the extension indicator has a separation of 25 mm between points and be at minimum of 25 mm from both the top and bottom jaws.

6.8.4 Holding Fixture

The holding fixtures may be any of the following types provided that the fixture does not cut the specimen or cause slippage.

- a) Air jaws;
- b) Drum jaws; and
- c) Manual jaws.

6.8.5 Calculation

Record the tensile strength directly from recording chart (stress strain curve) or digital readout.

Record the distance between benchmarks at the instant of break or rupture and note the jaw separation or the distance between benchmarks at the instant of rupture and calculate the percent elongation as follows:

$$\text{Elongation percent} = \frac{d_2 - d_1}{d_1} \times 100$$

where

- d_2 = distance at instant of break or rupture between jaws or benchmarks; and
- d_1 = original distance between jaws or benchmarks.

6.8.6 Report

Following information should be included in the report:

- a) Temperature conditions;
- b) Average breaking strength expressed in newtons per 10 mm of width. The maximum and minimum breaking strength among the readings, if specified; and
- c) Average percent elongation. The maximum and minimum percent elongation among the readings, if specified.

6.9 Adhesion Test

6.9.1 The method for conducting pipe coating adhesion testing to steel surface in a coating plant is described below. The tests shall be performed between 21 °C and 24 °C to achieve proper values. Adhesion test should be carried out after 24 h of application of the coating.

6.9.2 Adhesion Test Area

The adhesion test area shall be prepared in four steps:

- a) A circumferential strip measuring 25 mm wide × 375 mm long shall be marked on the coated pipe surface;

- b) The marked area shall then be cut to the steel substrate along the marked area on three sides (top and sides);
- c) A 25 mm strip shall be pried away from the substrate at the top end and attached with a suitable clamp to a pulling tension scale capable of measuring 0 kg to 23 kg; and
- d) The coated pipe shall then be marked at 25 mm increments along the length of a cut side with numbers from 1 to 12.

6.9.3 Adhesion Test Procedure

The adhesion test shall be conducted and evaluated in the following manner:

- a) Pull the tension scale at an angle of 180° to the pipe surface at a rate of 25 mm per 5 s continuously for 1 min;
- b) The pull tension value shall be recorded for each 25 mm of pull. A minimum of twelve values shall be recorded; and
- c) The two highest and two lowest values shall be excluded and the remaining eight values shall be averaged and recorded.

6.9.4 Record the separation mode exhibited during peel test. Primer separation from the steel surface during peel test is not an acceptable separation mode.

6.9.5 Rejection

An adhesion value below the requirement shall be considered a non-satisfactory result. In this situation, if the result is at least 90 percent of the requirement, two additional tests shall be made at two different locations on the same pipe. If the initial result is less than 90 percent of the requirement, or if either of the additional two tests fail to meet the requirement, the coating shall be repaired or rejected. If the coating fails an adhesion test, the test shall be repeated for the pipe coated prior to and after the failed pipe. This process shall be repeated until satisfactory results are obtained. All coated pipe where the requirement is not met shall be repaired or rejected.

6.9.6 The adhesion or peel force of the outer tape to inner tape shall also be conducted as above. This test is a laboratory test and not a field test. The minimum peel force or adhesion shall be as specified in [Table 3](#).

6.9.7 Frequency of testing of adhesion shall be performed as agreed between supplier and user.

6.10 Water Absorption Test

6.10.1 Apparatus

- a) *Weighing scale* — an analytical balance capable of reading 0.000 1 g; and
- b) *Oven* — capable of maintaining uniform temperatures of 50 °C ± 3 °C.

6.10.2 Test Specimen

This test is only applicable to inner layer tape. The test specimen size shall be 60 mm × 60 mm. The test specimens shall have smooth edges free from cracks.

6.10.3 Procedure

Either of the following two procedures can be used:

- a) *Twenty-four-hour immersion* — The conditioned specimens shall be placed in a container of distilled water maintained at a temperature of 23 °C ± 1 °C and shall rest on edge and be entirely immersed for the period of 24 h. At the end of 24 h, the specimens shall be removed from the water one at a time, all surface water wiped off with a dry cloth, weigh to the nearest 0.001 g immediately. If the specimen is 1.5 mm or less in thickness, it shall be put in a weighing bottle immediately after wiping and weighed in the bottle; and
- b) *Two-hour boiling water immersion* — The conditioned specimens shall be placed in a container of boiling distilled water, and shall be supported on edge and be entirely immersed. At the end of 120 min ± 4 min, the specimens shall be removed from the water and cooled in distilled water maintained at room temperature. After 15 min ± 1 min, the specimens shall be removed from the water, one at a time, all surface water removed with a dry cloth, and the specimens weighed to the nearest 0.001 g immediately. If the specimen is 1.5 mm or less in thickness, it shall be weighed in a weighing bottle.

6.10.4 Calculation

Percentage increase in weight during immersion, calculated to the nearest 0.01 percent as follows:

$$\begin{aligned} & \text{Increase in weight percent} \\ & = \frac{\text{Wet Weight} - \text{Conditioned Weight}}{\text{Conditioned Weight}} \times 100 \end{aligned}$$

6.11 Water Vapor Transmission

6.11.1 Apparatus

6.11.1.1 Test dish

The test dish shall be of any non-corroding material, impermeable to water or water vapor. The mouth of the test dish shall be as large as practical.

6.11.1.2 Attach the specimen to the test dish in such a manner that the test dish mouth defines the area of the specimen exposed to vapor pressure in the test dish.

6.11.1.3 The sealant used for attaching the specimen to the dish shall be highly resistant to passage of water vapor. It must not affect the vapor pressure in water filled dish. Molten wax/equivalent shall be used as sealant material.

6.11.2 Test Chamber

The cabinet where the assembled test dishes are to be placed shall have a controlled temperature and relative humidity.

The temperature chosen shall be between 21 °C and 32 °C and shall be maintained constant within ± 1 °C. The temperature of chamber walls facing to the specimen over water should not be cooler than water to avoid condensation on the test specimen.

The relative humidity shall be maintained at (50 ± 2) percent. Both temperature and relative humidity shall be recorded continuously.

Air shall be continuously circulated throughout the chamber, with a velocity sufficient to maintain uniform conditions at all test locations. The air velocity over the specimen shall be between 0.02 m/s and 0.3 m/s.

6.11.3 Balance and Weights

Analytical balance shall be used for measuring weight change during the test period and shall be sensitive to a change smaller than 0.001 g of the weight during the period when a steady state is considered to exist.

6.11.4 Test Specimens

The sample shall be of uniform thickness. If the material is of nonsymmetrical construction, the two faces shall be designated by distinguishing marks (for example, on a one-side-coated sample, I for the coated side and II for the uncoated side). Test specimens shall be representative of the material tested. When a product is designed for use in only one

position, three specimens shall be tested by the same method with the vapor flow in the designated direction.

The overall thickness of each specimen shall be measured at the center of each quadrant and the results should be averaged. Measurement of specimens of 3 mm or less in thickness shall be made to three decimal digits.

6.11.5 Test Procedure

Fill the test dish with distilled water to a level $19 \text{ mm} \pm 6 \text{ mm}$ from the specimen. The air space thus allowed has a small vapor resistance, but it is necessary in order to reduce the risk of water touching the specimen when the dish is handled.

Attach the specimen to the dish and place it in the controlled chamber, specimen up, weighing it immediately.

Weight the dish assembly every hour over the 24 h test period to provide at least 20 data points during the test. A data point is the weight at a particular time. The time that the weight is made shall be recorded to a precision approximately 1 percent of the time span between successive weighing. Weighing shall be accomplished without removal of the test dishes from the controlled atmosphere.

Relative humidity and the temperature in the controlled chamber shall also be continuously recorded.

6.11.6 Calculation for Water Vapor Transmission (WVT) and Permeance (Perms)

The water vapor transmission (WVT) rate shall be calculated using the following formula:

$$\text{WVT} = \frac{G}{tA} = \left(\frac{G}{t}\right) / A$$

where

WVT = rate of vapor transmission, in g/h.m^2 ;

G = weight change, in g;

t = time during which G occurred, in h;

A = test area (cup mouth area), m^2 ; and

G/t = slope of the straight line, in g/h .

The permeance (perms) shall be calculated using the following formula:

$$\text{Permeance} = \frac{\text{WVT}}{\Delta p} = \frac{\text{WVT}}{S(R_1 - R_2)} \times 100$$

where

Δp = vapor pressure difference in mm Hg ($1.333 \times 10^2 \text{ Pa}$);

S = saturation vapor pressure at test temperature, mm Hg;

R_1 = relative humidity at the source (in the test dish) expressed as a fraction; and

R_2 = relative humidity at the vapor sink (controlled chamber) expressed as a fraction.

6.12 Dielectric Strength

6.12.1 Apparatus

6.12.1.1 Voltage source

Obtain the test voltage from a step-up transformer supplied from variable sinusoidal low-voltage source. The transformer, its voltage source, and the associated controls shall have the following capabilities: The ratio of crest to root-mean-square (rms) test voltage shall be equal to 1.34 to 1.48, with the test specimen in the circuit, at all voltages greater than 50 percent of the breakdown voltage. The capacity of the source shall be sufficient to maintain the test voltage until dielectric breakdown occurs.

6.12.1.2 Voltage measurement

A voltmeter must be provided for measuring the rms test voltage. The overall error of the voltage-measuring circuit shall not exceed 5 percent of the measured value. The voltmeter shall be such that its time lag is not greater than 1 percent of full scale at any rate-of-rise used.

6.12.1.3 Electrodes

Opposing cylinders; the lower one 75 mm in diameter, 15 mm thick; the upper one 25 mm in diameter, 25 mm thick; with edges of both rounded to 3 mm in radius. The entire flat area of the electrode should be in contact with test specimen. The flatness and surface finish of the electrode faces must be such that the faces are in close contact with the test specimen over the entire area of the electrodes.

6.12.2 Test Specimens

Take 5 samples from areas that are not immediately adjacent to obvious defects or discontinuities in the material. The outer few layers of roll material, or material immediately next to an edge of a sheet or roll should be avoided. When flat-faced electrodes

are to be used, the surfaces of the specimens which are in contact with the electrodes shall be smooth parallel planes.

The recommended test specimen type for this test is a 101 mm plaque or larger. Test specimens over 2 mm thick are typically tested in oil to decrease the chance of flashover before breakdown.

6.12.3 Procedure

Voltage is applied across the two electrodes and raised from zero to dielectric breakdown at one of the followingsuitable uniform rates of 100 V/s, 200 V/s, 500 V/s, 1 000 V/s and 2 000 V/s (generally 500 V/s), which gives an average time to breakdown of between 10 s and 20 s, until breakdown. Breakdown is when an electrical burn-through punctures the sample, or decomposition occurs in the specimen. The rate of voltage rise is determined by the time it takes the sample to reach dielectric breakdown. This test is done commonly in air because of adhesive layer at one side.

6.12.4 Calculation

- Calculate the dielectric strength in kV/mm at breakdown;
- Dielectric strength = Breakdown voltage/thickness of sample; and
- Calculate the average dielectric strength of 5 samples.

6.13 Non Polyolefinic Material, Percent by Weight

Polyolefin backing compound contained in a disposable aluminum weighing dish is pyrolyzed in a muffle furnace for a short period. During the pyrolysis of the polymer, the air in the muffle furnace becomes oxygen-deficient to prevent the combustion of the residual non-polyolefin content primarily carbon black.

6.13.1 Apparatus

- Muffle furnace with temperature controller, approximately 100 mm in the three internal dimensions;
- Desiccator with alumina or equivalent desiccant;
- Laboratory interval timer with alarm;
- Disposable aluminum weighing dish; and
- Analytical balance, capable of measuring up to 0.1 mg.

6.13.2 Sample and Test Specimen

Samples may originate from the manufacturers or purchasers sampling regimen.

The test specimens may be in the form of granules or pieces cut from an article such as pipe coating, jacket, film, molding, soiled samples must be washed, and printed articles, such as films, are wiped clean with a suitable solvent.

6.13.3 Procedure

- Set the controller indicator of the muffle furnace to 600 °C and let it stabilize from 600 °C to 610 °C;
- Mark an aluminum weighing dish with an identifying impression on the tab;
- Place the dish on the screen in the muffle furnace and burn off the surface oil for 2 min, as indicated by timer;
- Transfer the dish to the desiccator and let it cool for at least 2 min;
- Weigh the dish accurately on the analytical balance. Record the results as W_1 ;
- Add about 1 g of specimen and reweigh the dish and contents accurately. Record the results as W_2 ;
- Place the weighed dish and contents into the muffle furnace and set the interval timer for 3 min;
- After the elapsed time, remove the dish from the muffle furnace and place it in the desiccator to cool for at least 2 min;
- Reweight the dish and remaining content accurately. Record the results as W_3 ;
- If mineral fillers are suspected to be present in the compound, replace the dish and contents into the muffle furnace for a period of 10 min or longer until only light-colored ash remains;
- Transfer the dish and contents from the muffle furnace to the desiccator and let it cool for 2 min;
- Re-weigh the dish and ash accurately. Record the results as W_4 ; and
- A minimum of two determinations is made for each sample.

6.13.4 Calculation

Calculate the percent non-polyolefinic content as

follows:

$$\text{Non-polyolefinic content \%} = \frac{W_3 - W_1}{W_2 - W_1} \times 100$$

or

$$\text{Non-polyolefinic content \%} = \frac{W_3 - W_4}{W_2 - W_1} \times 100$$

6.14 Holiday Detection

Holiday test is for locating discontinuities in a coating. The instrument used for this test is pulse type holiday detector which supplies a high voltage pulse for very short duration.

6.14.1 Grounding

Grounding both the pipe metal and the ground terminal of the holiday detector is necessary to complete the circuit.

6.14.2 Electrode Travel Speed

Pulse type holiday detector allows higher speed of travel of electrode. The minimum speed shall be 0.3 m/s.

6.14.3 Voltage Measurements

Voltage measurements of pulse type detectors shall be made with kilovolt meter. The electrode must in normal operating position on coated surface in a holiday free area. The voltage shall be measured between the electrode and the pipe.

6.14.4 Condition of Coating Surface

If the coated surface has excessive moisture, the coating system can cause appreciable leakage currents and cause erroneous holiday indication. Drying and leaning of the coated surface must be necessary.

6.14.5 Testing Voltage Calculation

Minimum testing voltage of a coating is given by the

formula:

Testing voltage $V = 7\,900\sqrt{T}$ is the target; at $\pm 20\%$ of the target is the allowed range,

where

T = average total coating thickness, in mm.

6.15 Impact Resistance Test

The test method consists of measuring the resistance of the coating to impact damage by dropping a spherical impactor on to the applied coating with a determined impact energy.

Freedom from damage is assessed by testing the impact site using a high voltage holiday detector.

6.15.1 Apparatus

The apparatus (*see* [Fig. 1](#)) shall consist of a weighted impactor (13) with a calibrated vertical guide (14) aligned over a horizontal support (6) for the coated test specimen (5).

The 25 mm \pm 0.1 mm diameter hemispherical hardened steel impactor (4) shall be fixed centrally to the lower end of a cylindrical steel falling body (outside diameter 35 mm \pm 0.5 mm) (13). The impactor shall be free from damage or irregularities. Total falling weights are given in [Table 7](#).

Table 7 Impact Energy

(Clauses [6.15.1](#) and [6.15.5](#))

Sl No.	Impact Energy, J	Total Falling Weight, g	Drop Height, mm
(1)	(2)	(3)	(4)
i)	4	408 \pm 2	1 000 \pm 5
ii)	8	815 \pm 4	1 000 \pm 5
iii)	15	1 529 \pm 7	1 000 \pm 5
iv)	30	3 058 \pm 15	1 000 \pm 5

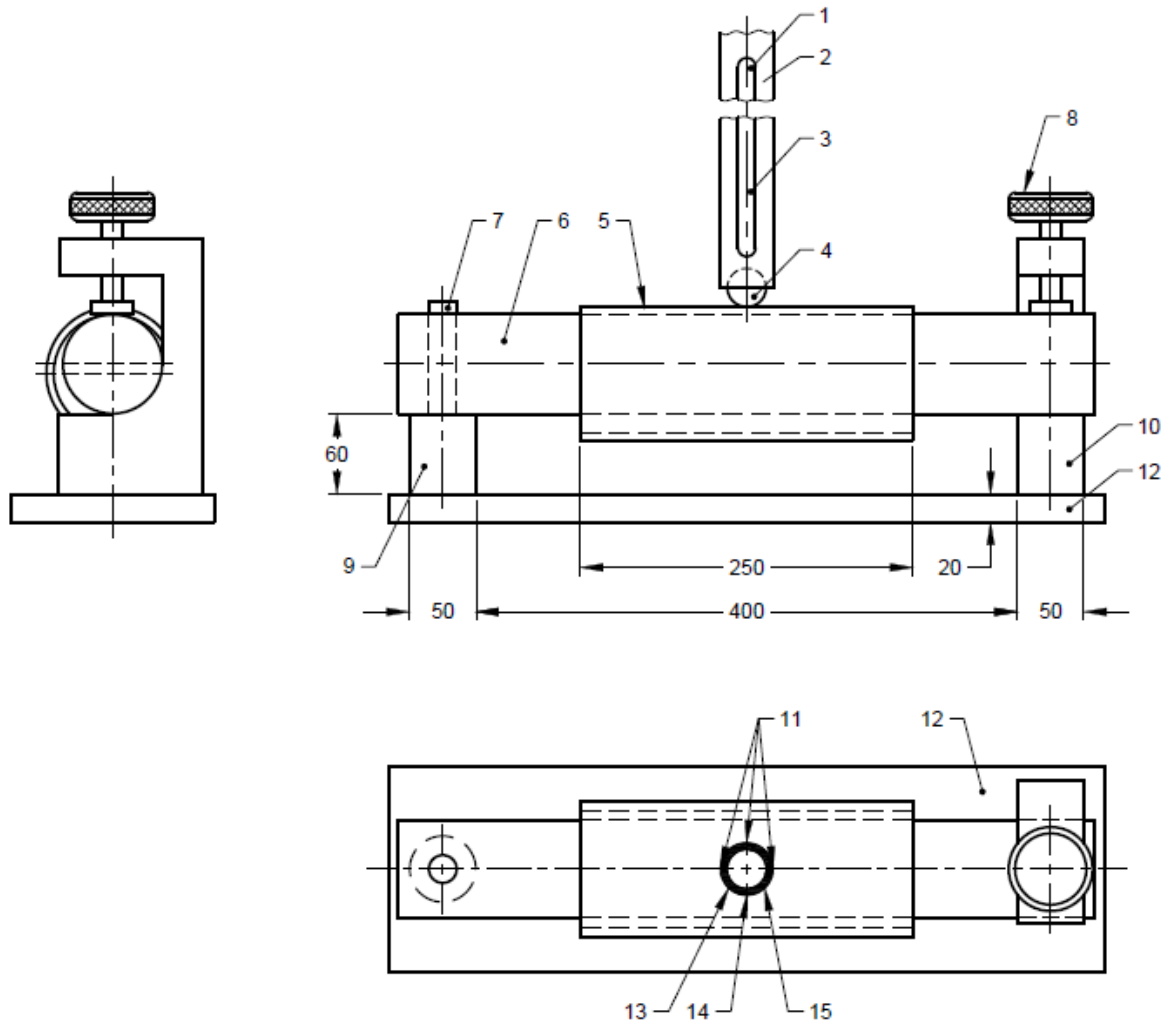

Key

- | | | | |
|---|---|----|---|
| 1 | Moving weight guide slot
(1 000 mm × 10 mm) | 9 | Gudgeon support (steel pillar) |
| 2 | Drop tube (40 mm) | 10 | Fixed support |
| 3 | Moving weight guide | 11 | Three air release slots
(10 mm × 1 000 mm) |
| 4 | Impactor (25 mm) | 12 | Support base (thickness 20 mm) |
| 5 | Specimen (coated steel pipe with 100 mm
nominal bore diameter) | 13 | Steel falling body (35 mm) |
| 6 | Support bar (75 mm) | 14 | Moving weight guide |
| 7 | Pintle (20 mm) | 15 | Drop tube |
| 8 | Support bar clamp | | |

All dimensions in millimetres.

FIG. 1 IMPACT TESTER

To determine intermediate values of impact resistance the drop height may be varied using the nearest higher falling weight.

The vertical guide consists of a vertical tube with internal diameter $40 \text{ mm} \pm 0.5 \text{ mm}$ (2), (15) with four 10 mm wide and 1 000 mm long slots (1), (11) [one for guide (3), (14) and three for air release (11)] or an equal device capable of guiding the fall of the weighted impactor with minimum friction on to the specimen from a predetermined height of up to 1 000 mm (impact energy *see* [Table 7](#)). A device for measuring the drop height with an accuracy of 5 mm shall be provided.

The horizontal specimen support (6) consists of a 75 mm diameter cylindrical steel bar supported at each end on steel pillars 60 mm high (9), (10). One end of the horizontal bar shall be hinged (7) and the other shall be clamped (8) (*see* [Fig. 1](#)). The length of the bar (6) between the pillars shall be $400 \text{ mm} \pm 5 \text{ mm}$.

- a) Length of 100 mm nominal bore diameter steel pipe shall be 250 mm and minimum wall thickness of 3 mm (5); and
- b) A high voltage holiday detector with a single probe capable of being set to a voltage of up to $15 \text{ kV} \pm 0.5 \text{ kV}$.

6.15.2 Preparation of Test Specimens

Prepare the surface of the pipe in accordance with the manufacturer's instruction.

6.15.3 Tapes

The required number of layers of each tape specified by the manufacturer shall be applied to the entire pipe length in accordance with the manufacturer's instruction except that they shall be applied spirally, edge to edge, without overlaps.

6.15.4 Shrinkable Materials

Shrinkable material coatings shall be applied to the entire pipe length in accordance with the manufacturer's instruction.

6.15.5 Procedure

Condition the coated test specimen for at least 2 h at $23 \text{ }^\circ\text{C} \pm 12 \text{ }^\circ\text{C}$. Support the coated test specimen on the horizontal support (6) (steel bar) of the test apparatus so that the impactor (4) shall fall vertically on to the crown.

Adjust the impact energy to the value specified in [Table 7](#) appropriate to the class of coating with an accuracy of 0.5 percent.

Allow the weighted impactor (13) to fall freely on the test specimen. Carefully raise the impactor (4) and test the impact site with high voltage holiday detector at a test voltage of 5 kV/mm of original thickness of the coating with a maximum of 15 kV.

Carry out 10 separate impacts on sites at least 30 mm apart.

Increase the impact energy by increments of 1 J and plot the impact energy against the number of perforations to obtain the maximum impact resistance.

6.15.6 Expression of Results

The coating shall pass the test at the specified impact energy if no holidays are recorded after 10 impacts. The maximum impact resistance shall be taken as the impact energy at the point of inflexion on the graph where the number of perforations increases rapidly.

6.16 Penetration Test

This accelerated test method is used to determine the relative resistance of steel pipeline coatings to penetration or deformation by a blunt rod under a specified load.

6.16.1 Apparatus

Test apparatus shall consist of:

- a) Chamber thermostatically controlled to $\pm 2 \text{ }^\circ\text{C}$ of the desired test temperature;
- b) Penetrometer comprising of dead weight tester that can press the flat tip of a rod against the coated pipe. The flat-tipped end of the rod contacting the coating shall have a diameter of $6.350 \text{ mm} \pm 0.025 \text{ mm}$ and together with supplementary weight and any other weight contributing parts shall have a total weight of 4.453 kg resulting in a unit pressure of 14.060 kg/cm^2 against the coating;
- c) Dial gauge or any other measurement system accurate to $\pm 0.01 \text{ mm}$;
- d) The test specimens shall be 150 mm long and prepared with its surface preparation and coating procedures equivalent to that of production coated pipe; and
- e) Thermometer, a temperature measurement device accurate to $\pm 0.5 \text{ }^\circ\text{C}$.

6.16.2 Procedure

The specimen shall be exposed to the test temperature for a period of 24 h before beginning the test. If the test temperature is the same as room temperature, it shall be carried out at a temperature of $23\text{ }^{\circ}\text{C} \pm 2\text{ }^{\circ}\text{C}$.

The test shall be performed three times on one coating sample and shall be completed on the installed coating system, as applied on the steel plate or pipe sample. The dimensions of the sample shall be agreed. Prior to conducting the penetration test, holiday test shall be conducted at the required holiday voltage as specified in [Table 4](#).

The test sample, held within the penetrometer assembly, shall be placed in the thermostatically controlled chamber and set to the test temperature $\pm 2\text{ }^{\circ}\text{C}$. The test sample shall be kept in the chamber for 1 h.

The following readings shall be made:

- a) t_0 is the reading on the dial gauge placed on an uncovered part of the steel plate or pipe;
- b) t_1 is the reading on the dial gauge with the indenter without the mass positioned centrally over the sample; and
- c) t_2 is the reading of the dial gauge after the mass has been applied, giving the total desired pressure on the indenter for a minimum duration of 24 h.

After the test is completed, the sample shall be subjected to holiday test at the required holiday voltage as specified in [Table 4](#).

6.16.3 Calculation

The quantities t_3 , the coating thickness; t_4 , the residual thickness of the coating; and t_5 , the penetration into the coating, can be calculated on the basis of the measurements described in E.3 using equations E.1 to E.3 respectively:

$$t_3 \text{ (coating thickness)} = t_1 - t_0 \quad (\text{E.1})$$

$$t_4 \text{ (residual coating thickness)} = t_2 - t_0 \quad (\text{E.2})$$

$$t_5 \text{ (penetration)} = t_1 - t_2 \quad (\text{E.3})$$

The arithmetic mean of the three individual determinations of each of the thicknesses t_3 , t_4 and t_5 shall be calculated and recorded.

The percentage penetration shall be calculated as follows: $\frac{t_5}{t_3} \times 100$

6.16.4 Result

The percentage penetration shall be recorded along with holiday voltage.

6.17 UV Resistance Test

The test method consists of measuring the effect of the outer tape to continuous irradiation of a xenon lamp under fixed temperature and humidity conditions. This test simulates weathering effect when the coating is subjected to sunlight, moisture, or rain during the outdoor storage of the coated pipes.

6.17.1 Apparatus

An irradiation chamber equipped with a xenon lamp.

6.17.2 Procedure

6.17.2.1 The test is carried out on outer layer tape designed for UV protection.

6.17.2.2 Cut one piece of sufficient size to prepare at least three test specimens required for the test.

6.17.2.3 The test should be conducted on specimen under the following conditions:

- a) artificial weathering;
- b) black standard temperature $65\text{ }^{\circ}\text{C} \pm 3\text{ }^{\circ}\text{C}$;
- c) relative humidity (65 ± 5) percent;
- d) spray cycle 18 min, 102 min dry;
- e) irradiance $60\text{ W/m}^2 \pm 2\text{ W/m}^2$ broadband (300 nm to 400 nm); and
- f) continuous exposure for 2 088 h (approx. 87 days).

6.17.2.4 The three irradiated test specimens taken from tested pieces under identical conditions within 8 h and evaluated according to [6.17.3](#).

6.17.3 Result

There shall be no visual cracks on the tape surface.

6.18 Cathodic Disbondment Test

The test consists of assessing the resistance to disbondment of damage polyethylene/polyolefin tape coating when exposed to cathodic polarization.

The test shall be performed on a test sample previously subjected to holiday detection and in which an artificial defect of a defined size has been created.

6.18.1 Apparatus

6.18.1.1 Electrical source, consisting of a controlled voltage d.c. power unit (potentiostat) capable of supplying 20 mA to each test area simultaneously.

Cathodic polarization potential (E) equivalent to $-1\ 500$ mV versus saturated calomel reference electrode shall be maintained. E equals to $-1\ 500$ mV when a saturated calomel reference electrode is used. The potentials are defined as follows:

- a) “ E ” is the potential of the “working electrode” with regard to the “reference electrode”; and
- b) “ V ” is the difference of potential between the “working electrode” and the “auxiliary electrode”.

6.18.1.2 Electrolytic cell, having a typical test-cell configuration as shown in Fig. 2. The electrolytic cell shall comprise of:

- a) a rigid plastic pipe with an internal diameter of minimum 50 mm. The height shall be such that the total volume of the electrolyte is equal to or greater than 150 cm^3 with a minimum height of the electrolyte of 70 mm; and
- b) a rigid plastic cover in which holes shall be drilled to allow the passage of the electrodes and any other measuring instruments deemed necessary, and to allow the escape of hydrogen.

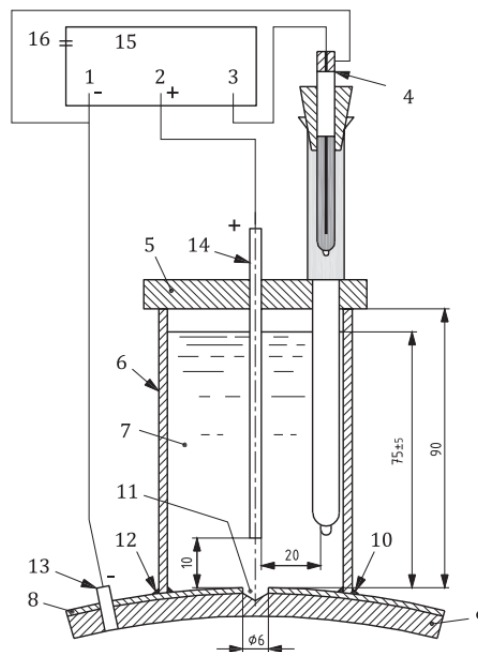

Key

- | | |
|--|--|
| 1 Connection to working electrode | 10 Sealing material |
| 2 Connection to auxiliary electrode (anode) | 11 Artificial defect, \varnothing 3 mm to 6 mm if coating thickness is less than 1 mm; \varnothing 6 mm in other cases |
| 3 Connection to reference electrode | 12 Sealing material |
| 4 Reference electrode | 13 Working electrode (cathode) |
| 5 Plastic cover | 14 Platinum electrode, \varnothing 0.8 mm to 1.0 mm (anode) |
| 6 Plastic pipe, minimum internal \varnothing 50 mm | 15 Potentiostat |
| 7 Electrolyte ≥ 150 ml | 16 220 V power supply |
| 8 Coating | |
| 9 Steel test piece | |

FIG. 2 ELECTROLYTIC CELL FOR LARGE-DIAMETER PIPE

6.18.1.3 Reference electrode shall be saturated calomel capable of measuring suitable potential – 1 500 mV and suitable for the test temperature required, placed in an electrode holder situated in a glass pipe with a porous end diaphragm. The end of this assembly shall be placed approximately 10 mm from the surface of the coating and approximately 20 mm from the coating defect.

6.18.1.4 Anode, consisting of an inert material, for example, platinum wire, 0.8 mm to 1.0 mm in diameter. It shall be immersed in the electrolyte to within approximately 10 mm over the coating defect. The ratio of the surface area of the anode to that of the cathode shall be greater than 1.

6.18.1.5 Cathode, represented by the artificial defect, 6 mm in diameter, with a maximum depth of 0.5 mm in the steel substrate.

6.18.1.6 Electrolyte, consisting of a 3 percent solution of NaCl in distilled or deionized water. The solution shall be made from technical grade sodium chloride. The pH at 23 °C ± 2 °C during the test shall be in the range of 6 to 9. The height of the electrolyte in the cell shall be at least 70 mm.

6.18.1.7 Heating equipment, suitable to establish and to maintain the test temperature of the sample. If not heated in an oven, the temperature shall be checked on the artificial defect by an appropriate means, for example a temperature sensor.

6.18.2 *Sampling*

The test shall be performed on a coated pipe and three cathodic disbondment tests shall be performed. The thickness of the area of the coating subject to the test shall be measured and recorded.

The integrity of the coating on all test samples shall be checked by holiday detection.

A 6 mm diameter hole through the coating shall be obtained by drilling. The depth of the hole in the steel substrate shall not exceed 0.5 mm. At the initiation of the test, the total surface area subject to the test shall be free from residual coating. The test area shall be degreased using a suitable solvent and then rinsed with potable water and subsequently dried.

6.18.3 *Procedure*

The plastic pipe forming the electrolytic cell shall be sealed using a suitable sealant, for example, a

chemically inert adhesive. The artificial defect shall be in the centre of the cell.

The cell shall be filled with the NaCl electrolyte. The test temperature shall be controlled within 23 °C ± 2 °C.

A negative cathodic potential – 1 500 mV ± 10 mV shall be measured between the reference electrode and cathode (pipe).

The test shall be performed for the test period of 30 days. The level of the electrolyte shall be readjusted with distilled or deionized water, if necessary.

6.18.4 *Investigation Procedure*

After the test, the cell with the electrolyte shall be removed. The test sample shall be rinsed with water and dried. After drying, the area of the coating subjected to the test shall be examined in accordance with the following method:

- a) Inspect and assess each coating immediately after the test period;
- b) Make about 6 radial incisions using a sharp knife, through the coating to the substrate, extending outwards from the holiday for a distance of at least 40 mm. Make these incisions at an angle of approximately 60° from each other;
- c) Insert the knife point into the center portion of the holiday down to the metal substrate. Using a gentle levering action, peel away slowly a radial section of coating continuing until firm adhesion is encountered;
- d) Repeat with each radial segment; and
- e) Measure the length from the edge of the holiday area to the furthest extent for each segment.

6.18.5 *Results*

The result of the cathodic disbondment test shall be defined as the arithmetic mean value of the 6 single values. The mean value shall be recorded.

7 *Inspection and Testing*

Inspection and testing are to be carried out as per [Table 8](#).

Table 8 Requirements for Inspection and Testing

(Clause 7)

SI No.	Properties	Test Method	Requirements	Frequency for Qualification Test	Frequency During Production
(1)	(2)	(3)	(4)	(5)	(6)
i)	a) Surface condition before blasting	Visual inspection	Free of contamination from oil, grease and chlorides	Each pipe	Each pipe
	b) Surface condition after blasting	Conductive measurement	20 mg/m ² , <i>Max</i> as per ISO 8502-9	Each pipe	5 pipes at start of production and 1 pipe/shift
ii)	Environmental conditions (dew point)	Calculation	RH 85 %, <i>Max</i>	Once	Every 4 h
iii)	Pipe temp before blasting	Thermocouple	3 °C, <i>Min</i> , above dew point	Once	Every 4 h
iv)	Size, shape and properties of abrasive	Visual + Certification to ISO 11124-1 and ISO 11126-1	Conformity to certificate provided by the manufacturer	Once	1/day
v)	Water soluble contaminants of abrasives	ISO 11127-6	Salt content 20 mg/m ² , <i>Max</i> as per ISO 8502-9	Once	1/shift
vi)	Surface roughness of blasted steel	ISO 8503-4	50 microns to 75 microns	Each pipe	Each pipe
vii)	Visual inspection of blasted surface	ISO 8501-1	Grade Sa 2.5	Each pipe	Each pipe
viii)	Presence of dust after dust removal	ISO 8502-3	Class 2, <i>Max</i>	5 pipes	Every 1 h
ix)	Elapsed time between blasting and coating	Monitoring	No rust, Pipe temp at least 3 °C above dew point	Continuously	Continuously
x)	Liquid adhesive application	Visual	Total coverage and wetting of pipe surface, without runs and sags (dry to touch)	Each pipe	Each pipe

Table 8 (Continued)

SI No.	Properties	Test Method	Requirements	Frequency for Qualification Test	Frequency During Production
(1)	(2)	(3)	(4)	(5)	(6)
xi)	Liquid adhesive thickness	DFT	50 microns to 75 microns	10 locations/pipe	5 locations/pipe
xii)	Application of inner tape using manufacturer recommended wrapping machine	Visual	Coating free of air pocket sand wrinkles	Each pipe	Each pipe
xiii)	Neck-down tension on the inner tape while wrapping	Measurement	2 % of tape width	Random; 10 measurement/pipe	Random; 5 measurement/pipe
xiv)	Check overlap of the inner tape	Measurement	25 mm, <i>Min</i>	Random; 10 measurement/pipe	Random; 5 measurement/pipe
xv)	Holiday test on inner tape	Testing by holiday machine	Passes at 6 kV	Each pipe	Each pipe
xvi)	Application of middle layer tape using manufacturer recommended wrapping machine	Visual	Staggered on the inner layer tape by 25 % the width of the tape	Each pipe	Each pipe
xvii)	Neck-down tension on the middle layer tape while wrapping	Measurement	2 % of tape width	Random; 10 measurement/pipe	Random; 5 measurement/pipe
xviii)	Check overlap of the inner pipe	Measurement	25 mm, <i>Min</i>	Random; 10 measurement/pipe	Random; 5 measurement/pipe
xix)	Installed coating-holiday test	Testing by holiday machine	Passes at 12 kV	Each pipe	Each pipe
xx)	Installed coating-adhesion test of the inner layer to steel	Measurement	2 200 N/m width	5 per pipe	One in every 10 pipes
xxi)	Installed coating-adhesion test of the outer layer to inner layer	Measurement	200 N/m (600 N/m) width	5 per pipe	One in every 10 pipes
xxii)	Installed coating-thickness test (minimum)			4 locations/pipe	4 locations/pipe
	a) Type A	Measurement	1.17 mm, <i>Min</i>		
	b) Type B	Measurement	1.85 mm, <i>Min</i>		

Table 8 (Concluded)

SI No.	Properties	Test Method	Requirements	Frequency for Qualification Test	Frequency During Production
(1)	(2)	(3)	(4)	(5)	(6)
xxiii)	Installed coating-coating cutback	Measurement	150 ± 20 mm	Each pipe	Each pipe
xxiv)	Coating repairs	Visual, holiday detection	No holidays	Once for demonstration	Each defect

8 SAMPLING AND CRITERIA FOR CONFORMITY

8.1 The scale of sampling shall be as per 3 of IS 8402.

8.2 Number of Tests

Tests for the determination of all the requirements of the specification given in [Table 2](#) shall be performed on inner layer tape, [Table 3](#) shall be performed on outer layer tape and [Table 4](#) shall be performed on total coating system.

8.3 Criteria for Conformity

The lot shall be declared as conforming to the requirements of the specification if test results as obtained meets the corresponding requirements given in the standard.

8.4 Coating Materials Acceptance Testing

For acceptance of coating materials, one of the following methods shall be used:

- a) Test report from manufacturer/supplier;
- b) Test report from by third party lab certified as per IS/ISO/IEC 17025; and
- c) Acceptance as agreed between the purchaser and the supplier.

9 PACKAGING AND MARKING

9.1 Packaging

A suitable film separator shall be applied to the finished tape to prevent different layers of tape in a roll from sticking to each other. The film separator shall however be removed prior to application of tape. Packaging should be as agreed between the purchaser and supplier.

9.2 Marking

9.2.1 Each tape shall be marked with following information:

- a) Trademark or brand name;
- b) Product name/type; and
- c) Batch or lot number.

9.2.2 Each packaging shall be marked legibly with the following information:

- a) Name and type of material;
- b) Indication of source of manufacture;
- c) Month and year of manufacture;
- d) Length and width of the tape;
- e) Batch number of manufacture;
- f) Directions for storage and use; and
- g) Any other information relating to retention of quality of the tape at the customer's end including guidelines regarding storage of the tapes and primer.

9.3 BIS Certification Marking

The product(s) conforming to the requirements of this standard may be certified as per the conformity assessment schemes under the provisions of the *Bureau of Indian Standards Act, 2016* and the Rules and Regulations framed thereunder, and the products may be marked with the Standard Mark.

9.4 Handling, Transportation and Storage of Coated Pipes

The care shall be taken to load, unload, transport and stock pile the coated pipes within the coating plant using suitable means to avoid damage to the pipe and coating. It shall be agreed prior to commencement of work.

Coated pipes may be handled by means of slings of belts of proper width (minimum 60 mm) made of non-abrassive/non-metallic materials. The pipes shall be stacked completely clear from the ground at least 300 mm so that bottom row of pipes remain free from any surface water. The pipes shall be stacked at a slope so that draining rain does not collect inside the pipe. The lorries used for transportation shall be equipped with adequate pipe supports having as many round hollow beds as there are pipes to be placed on the bottom of the lorry bed. Total width of supports shall be at least 5 percent of the pipe length and minimum 3 in number support shall be provided.

ANNEX A

(Clause 2)

LIST OF REFERRED STANDARDS

<i>IS No./Other Standards</i>	<i>Title</i>	<i>IS No./Other Standards</i>	<i>Title</i>
IS 101 (Part 1/Sec 6) : 1987	Method of sampling and test for paints, varnishes and related products: Part 1 Tests on liquid paints (general and physical), Section 6 Flash point (<i>third revision</i>)	ISO 8502-3 : 2017	substrates after overall removal of previous coatings Preparation of steel substrates before application of paints and related products — Tests for the assessment of surface cleanliness — Part 3: Assessment of dust on steel surfaces prepared for painting (pressure-sensitive tape method)
IS 101 (Part 1/Sec 7) : 2020/ ISO 2811-1 : 2016	Methods of sampling and test for paints, varnishes and related products: Part 1 Test on liquid paints (general and physical), Section 7 Mass per 10 litres — Determination of density — Pycnometer method (<i>fourth revision</i>)	ISO 8502-9 : 2020	Preparation of steel substrates before application of paints and related products — Tests for the assessment of surface cleanliness — Part 9: Field method for the conductometric determination of water-soluble salts
IS 3589 : 2001	Steel pipes for water and sewage (168.3 to 2 540 mm outside diameter) — Specification (<i>third revision</i>)		
IS 8402 : 1987	Methods of sampling and test for pressure sensitive adhesive tapes (<i>first revision</i>)	ISO 8503-4 : 2012	Preparation of steel substrates before application of paints and related products — Surface roughness characteristics of blast-cleaned steel substrates — Part 4: Method for the calibration of ISO surface profile comparators and for the determination of surface profile — Stylus instrument procedure
IS 9954 : 1981	Pictorial surface preparation standards for painting of steel surfaces		
IS 10810 (Part 6) : 1984	Methods of test for cables: Part 6 Thickness of thermoplastic and elastomeric insulation and sheath		
IS/ISO/IEC 17025 : 2017	General requirements for the competence of testing and calibration laboratories (<i>second revision</i>)	ISO 8503-5 : 2017	Preparation of steel substrates before application of paints and related products — Surface roughness characteristics of blast-cleaned steel substrates — Part 5: Replica tape method for the determination of the surface profile
ISO 8501-1 : 2007	Preparation of steel substrates before application of paints and related products — Visual assessment of surface cleanliness — Part 1: Rust grades and preparation grades of uncoated steel substrates and of steel		

IS 18910 : 2024

<i>IS No./Other Standards</i>	<i>Title</i>	<i>IS No./Other Standards</i>	<i>Title</i>
ISO 11124-1 : 2018	Preparation of steel substrates before application of paints and related products — Specifications for metallic blast-cleaning abrasives — Part 1: General introduction and classification	ISO 11127-6 : 2022	abrasives — Part 1: General introduction and classification Preparation of steel substrates before application of paints and related products — Test methods for non-metallic blast-cleaning abrasives — Part 6: Determination of water-soluble contaminants by conductivity measurement
ISO 11126-1 : 2018	Preparation of steel substrates before application of paints and related products — Specifications for non-metallic blast-cleaning		

To access Indian Standards click on the link below:

https://www.services.bis.gov.in/php/BIS_2.0/bisconnect/knownyourstandards/Indian_standards/isdetails/

ANNEX B

(Foreword)

COMMITTEE COMPOSITION

Corrosion Protection and Finishes Sectional Committee, MTD 24

<i>Organization</i>	<i>Representative(s)</i>
Homi Bhabha National Institute, Mumbai	DR U. KAMACHI MUDALI (<i>Chairperson</i>)
Bhabha Atomic Research Centre, Mumbai	SHRI SUPRATIK ROYCHOWDHARY SHRI PARAG AHMEDBADI (<i>Alternate I</i>) SHRI SARADI GUMMA (<i>Alternate II</i>)
Bharat Heavy Electrical Limited, Hyderabad	DR A. K. MAITI SHRI RAHUL KASHYAP (<i>Alternate</i>)
Confederation of Indian Industry, New Delhi	DR JASPREET KAUR SHRI NITIN KUMAR (<i>Alternate</i>)
CSIR - Central Electrochemical Research Institute, Karaikudi	DR RAKESH C. BARIK DR C. ARUNCHANDRAN (<i>Alternate</i>)
CSIR - National Aerospace Laboratories, Bengaluru	DR J. N. BALARAJU DR PRAKASH B. (<i>Alternate</i>)
CSIR - National Metallurgical Laboratory, Jamshedpur	DR S. K. TIWARI DR RAGHUVIR SINGH (<i>Alternate</i>)
Directorate General of Quality Assurance, Ministry of Defence, Ichapur	SHRI K. YADAV SHRI T. K. PRUSTY (<i>Alternate</i>)
Engineers India Limited, New Delhi	SHRI ARIJIT ROY SHRI PRABHAKAR CHOWDHARY (<i>Alternate</i>)
GAIL (India) Limited, New Delhi	SHRI SHIV SHANKER VERMA SHRI UPENDRA NATH BHASKAR (<i>Alternate I</i>) SHRI MOHAMMAD SHUMS ABBAS (<i>Alternate II</i>)
Indian Lead Zinc Development Association, New Delhi	SHRI K. SRIDHAR SHRI L. PUGAZHENTHY (<i>Alternate</i>)
Indira Gandhi Centre for Atomic Research, Kalpakkam	DR S. NINGSHEN DR S. C. VANITHA KUMARI (<i>Alternate</i>)
Lalita Infraprojects Private Limited, Kolkata	DR BUDDHADEB DUARI SHRI KAUSHIK DUARI (<i>Alternate I</i>) SHRI SUBHAJIT BHATTACHARYA (<i>Alternate II</i>)
Ministry of Railways, (RDSO), Lucknow	SHRI C. SENGUPTA DR P. K. BALA (<i>Alternate</i>)
National Thermal Power Corporation Limited, New Delhi	SHRI SUDHAKAR PANJALA SHRI CHANDER SHEKHAR (<i>Alternate</i>)
Naval Materials Research Laboratory, Thane	DR G. GUNASEKARAN DR CHINTA SRINIVASA RAO (<i>Alternate</i>)
Oil and Natural Gas Corporation Limited, Mumbai	SHRIMATI MAUSHUMI K.

IS 18910 : 2024

<i>Organization</i>	<i>Representative(s)</i>
Steel Authority of India Limited (SAIL), Research & Development Centre for Iron & Steel, Ranchi	DR P. SARAVANAN SHRIMATI B. KHALKHO (<i>Alternate</i>)
Tata Steel Limited, Jamshedpur	DR A. N. BHAGAT DR TAPAN KUMAR ROUT (<i>Alternate</i>)
BIS Directorate General	SHRI SANJIV MAINI, SCIENTIST 'F'/SENIOR DIRECTOR AND HEAD (METALLURGICAL ENGINEERING) [REPRESENTING DIRECTOR GENERAL (<i>Ex-officio</i>)]

Member Secretary
SHRI DUSHYANT HAWELIKAR
SCIENTIST 'C'/DEPUTY DIRECTOR
(METALLURGICAL ENGINEERING), BIS

Working Group Composition

Working Group 1 on Cold Applied (Polyethylene/Polyolefin) Tape Coating

<i>Organization</i>	<i>Representative(s)</i>
Lalita Infraprojects Private Limited, Kolkata	DR BUDDHADEB DUARI (<i>Convener</i>) DR KAUSHIK DUARI
Seal for Life India Private Limited, Vadodara	SHRI ABHISHEK KAPUR SHRI JENISH TRIVEDI (<i>Alternate</i>)

Bureau of Indian Standards

BIS is a statutory institution established under the *Bureau of Indian Standards Act, 2016* to promote harmonious development of the activities of standardization, marking and quality certification of goods and attending to connected matters in the country.

Copyright

BIS has the copyright of all its publications. No part of these publications may be reproduced in any form without the prior permission in writing of BIS. This does not preclude the free use, in the course of implementing the standard, of necessary details, such as symbols and sizes, type or grade designations. Enquiries relating to copyright be addressed to the Head (Publication & Sales), BIS.

Review of Indian Standards

Amendments are issued to standards as the need arises on the basis of comments. Standards are also reviewed periodically; a standard along with amendments is reaffirmed when such review indicates that no changes are needed; if the review indicates that changes are needed, it is taken up for revision. Users of Indian Standards should ascertain that they are in possession of the latest amendments or edition by referring to the website-www.bis.gov.in or www.standardsbis.in.

This Indian Standard has been developed from Doc No.: MTD 24 (22071).

Amendments Issued Since Publication

Amend No.	Date of Issue	Text Affected

BUREAU OF INDIAN STANDARDS

Headquarters:

Manak Bhavan, 9 Bahadur Shah Zafar Marg, New Delhi 110002

Telephones: 2323 0131, 2323 3375, 2323 9402

Website: www.bis.gov.in

Regional Offices:

Central : 601/A, Konnectus Tower -1, 6th Floor,
DMRC Building, Bhavbhuti Marg, New
Delhi 110002

Telephones

{ 2323 7617

Eastern : 8th Floor, Plot No 7/7 & 7/8, CP Block, Sector V,
Salt Lake, Kolkata, West Bengal 700091

{ 2367 0012
2320 9474

Northern : Plot No. 4-A, Sector 27-B, Madhya Marg,
Chandigarh 160019

{ 265 9930

Southern : C.I.T. Campus, IV Cross Road, Taramani, Chennai 600113

{ 2254 1442
2254 1216

Western : 5th Floor/MTNL CETTM, Technology Street, Hiranandani Gardens, Powai
Mumbai 400076

{ 25700030
25702715

Branches : AHMEDABAD, BENGALURU, BHOPAL, BHUBANESHWAR, CHANDIGARH, CHENNAI, COIMBATORE, DEHRADUN, DELHI, FARIDABAD, GHAZIABAD, GUWAHATI, HARYANA (CHANDIGARH), HUBLI, HYDERABAD, JAIPUR, JAMMU, JAMSHEDPUR, KOCHI, KOLKATA, LUCKNOW, MADURAI, MUMBAI, NAGPUR, NOIDA, PARWANOO, PATNA, PUNE, RAIPUR, RAJKOT, SURAT, VIJAYAWADA.