

लचीले शाफ्ट्स — विशिष्टि
(पहला पुनरीक्षण)

Flexible Shafts — Specification
(First Revision)

ICS 21.120.10

© BIS 2024



भारतीय मानक ब्यूरो
BUREAU OF INDIAN STANDARDS
मानक भवन, 9 बहादुर शाह ज़फर मार्ग, नई दिल्ली - 110002
MANAK BHAVAN, 9 BAHADUR SHAH ZAFAR MARG
NEW DELHI - 110002

www.bis.gov.in www.standardsbis.in

July 2024

Price Group 7

FOREWORD

This Indian Standard (First Revision) was adopted by the Bureau of Indian Standards after the draft finalized by the Transmission Devices Sectional Committee had been approved by the Production and General Engineering Division Council.

This standard was first published in 1968. This revision has been taken up to keep pace with the latest technological developments and international practices.

This standard has been prepared with a view to achieve uniformity in the manufacture and easy inter changeability of parts of flexible shafts.

Flexible shafts make it possible to transmit power or to provide remote control between any two points with a single self-contained element, regardless of the relative position of the two points or obstacles on the path between them.

Flexible shafts are mechanical power-transmission devices used to transmit rotary motion through bends and curves. They can be routed over, under, and around obstacles which would be otherwise impossible for a solid shaft and costly for universal joints.

A flexible shaft system uses a motor to rotate a flexible shaft. The end of the shaft contains a hand piece, which contains the desired-shape. It is operated by an adjustable power source. Flexible shaft hand piece accessories include burs, drill bits, polishing wheels, or brushes.

The composition of the Committee responsible for formulation of this standard is given in [Annex A](#).

For the purpose of deciding whether a particular requirement of this standard is complied with, the final value, observed or calculated, expressing the result of a test or analysis, shall be rounded off in accordance with IS 2 : 2022 'Rules for rounding off numerical values (*second revision*)'. The number of significant places retained in the rounded off value should be the same as that of the specified value in this standard.

Indian Standard

FLEXIBLE SHAFTS — SPECIFICATION

(*First Revision*)

1 SCOPE

This standard covers the requirements and principal dimensions of flexible shafts for industrial purposes.

2 REFERENCES

The standard given below contain provisions, which through reference in this text, constitute provisions of this standard. At the time of publication, the editions indicated was valid. All standards are subject to revision and encouraged to investigate the possibility of applying the most recent edition of this standard:

<i>IS No.</i>	<i>Title</i>
IS 4454 (Part 1): 2001	Steel wire for mechanical springs — Specification Part 1: Cold drawn unalloyed steel wire (<i>third revision</i>)

3 TERMINOLOGY

For the purpose of this standard, the following definitions shall apply:

3.1 Direction of Rotation — The direction which tightens up the outer layer of the inner shaft.

3.2 End Stiffener — A member helically wound and slipped over either end of the outer casing to prevent excessive bend of the shaft near the ends.

3.3 Flexible Shaft Assembly — A combination of inner shaft assembly and co-ordinated outer casing assembly. Practically all applications of the flexible shaft require a flexible shaft assembly.

3.4 Inner Shaft — The bare working element without end fittings.

3.5 Inner Shaft Assembly — The inner shaft with end fittings attached or one with integrally formed squares.

3.6 Outer Casing — A flexible covering in the form of tube which acts as a runway or guide for the inner shaft, protects it from dirt and injury, assists in retaining lubrication and prevents formation of loops in operation.

3.7 Outer Casing Assembly — The outer casing with end fittings attached.

3.8 Outer Casing end Fittings — Parts used for fastening to the ends of the outer casing, by means of which the outer casing is connected or coupled to the driving and driven elements (*see Fig. 1*).

3.9 Lay of the Shaft — The pitch direction of the outer layer of shaft. Depending upon the direction of lay, shaft shall be specified as right lay or left lay.

3.10 Shaft end Fittings — Parts for fastening to the ends of the inner shaft by means of which the flexible shaft assembly is connected to the driving and driven elements.

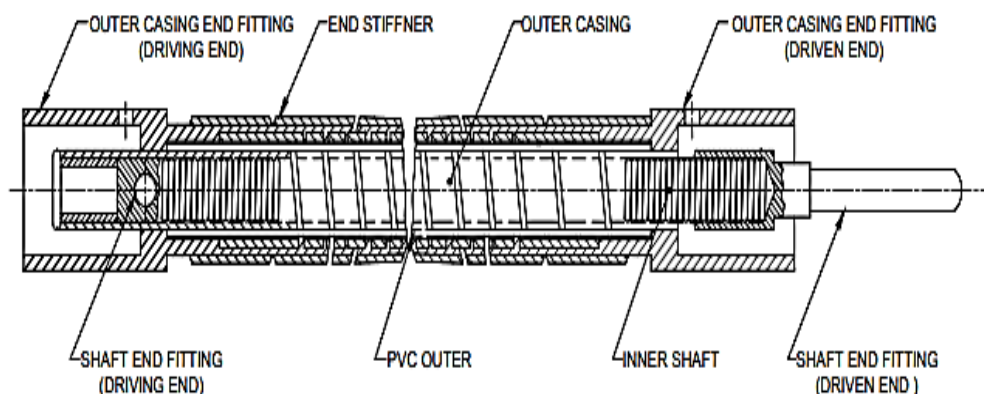

FIG. 1 FLEXIBLE SHAFT ASSEMBLY

4 MATERIALS AND MECHANICAL PROPERTIES

4.1 Inner Shaft — The inner shaft shall be made of spring steel according to IS 4454 (Part 1).

4.2 Outer Casing — The outer casing shall have an inner liner of suitable steel having a minimum tensile strength of 120 kgf/mm² with rolled rounded edge.

5 DIMENSIONS

The dimensions of flexible shaft assembly covered

in this standard are of two types, namely, Type A and Type B as given below:

- a) Type A — Threaded shaft end fittings on both ends with the outer casing sliding at the driving end. The dimensions of Type A flexible shaft assembly and their parts shall be as given in [Table 1](#) and [Table 2](#).
- b) Type B — Fixed outer casing end fittings on both ends and sliding shaft end fittings at the driven end. The dimensions of Type B flexible shaft assembly and their parts shall be as given in [Table 3](#).

Table 1 Dimensions for Flexible Shafts

[[Clause 5 \(a\)](#)]

All dimensions are in millimeters.

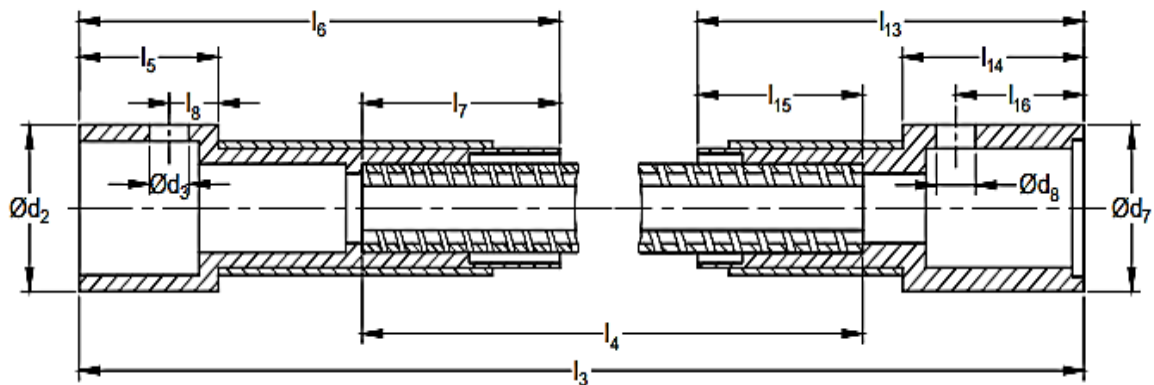

OUTER CASING ASSEMBLY

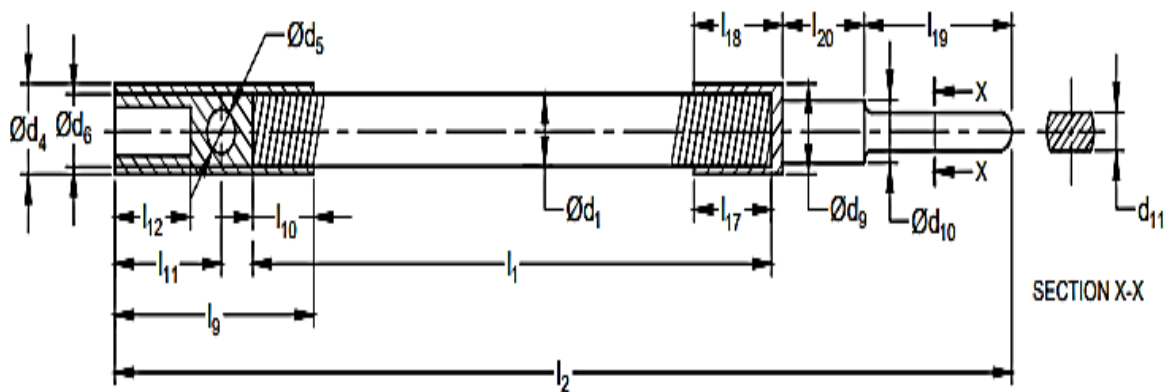

INNER SHAFT ASSEMBLY

Table 1 (Concluded)

SI No.	Designation	d ₁	d ₂	d ₃	d ₄	d ₅	d ₆	d ₇	d ₈	d ₉	l ₁	l ₂	l ₃	l ₄	l ₅	l ₆	l ₇	l ₈	l ₉	l ₁₀	l ₁₁	l ₁₂	l ₁₃	l ₁₄	l ₁₅	l ₁₆
(1)	(2)	(3)	(4)	(5)	(6)	(7)	(8)	(9)	(10)	(11)	(12)	(13)	(14)	(15)	(16)	(17)	(18)	(19)	(20)	(21)	(22)	(23)	(24)	(25)	(26)	(27)
i)	7 × 1 500	7	22	12.0	5	M10	8.5	5.0	3.9	7.5	1 500	1 590	1 547	1 463	30	75	33	40	11	24	18	20	15	20	18	38
ii)	7 × 2 000	7	22	12.0	5	M10	8.5	5.0	3.9	7.5	2 000	2 090	2 047	1 963	30	75	33	40	11	24	18	20	15	20	18	38
iii)	10 × 1 500	10	28	12.0	5	M10	12.0	7.5	5.9	7.5	1 500	1 605	1 548	1 448	40	90	40	47	15	25	18	28	20	23	18	52
iv)	10 × 2 000	10	28	12.0	5	M10	12.0	7.5	5.9	7.5	2 000	2 105	2 048	1 948	40	90	40	47	15	25	18	28	20	23	18	52
v)	12 × 1 500	12	28	14.0	5	M10	14.0	7.5	5.9	11.0	1 500	1 607	1 550	1 450	40	95	40	50	18	25	18	28	25	30	18	52
vi)	12 × 2 000	12	28	14.0	5	M10	14.0	7.5	5.9	11.0	2 000	2 107	2 050	1 950	40	95	40	50	18	25	18	28	25	30	18	52
vii)	15 × 2 000	15	35	17.5	7	M14	17.5	10.0	8.9	11.0	2 000	2 109	2 059	1 959	50	95	45	64	26	33	23	34	25	28	13	55
viii)	15 × 3 000	15	35	17.5	7	M14	17.5	11.0	8.9	11.0	3 000	3 109	3 059	2 959	50	95	45	64	26	33	23	34	25	28	13	55
ix)	20 × 2 000	20	40	23.0	7	M14	—	—	—	—	2 000	2 086	2 110	1 960	43	110	35	73	30	33	23	27	—	—	—	—
x)	20 × 3 000	20	40	23.0	7	M14	—	—	—	—	3 000	3 086	2 110	2 960	43	110	35	73	30	33	23	27	—	—	—	—

NOTE — The dimensions given for 20 mm shaft are for the type where the shaft has a threaded (fixed) connection at both aides and not sliding at the tool holder.

Table 2 Dimensions of Type A Flexible Shaft Assembly and Parts

[Clause 5(a)]

All dimension are in millimeters.

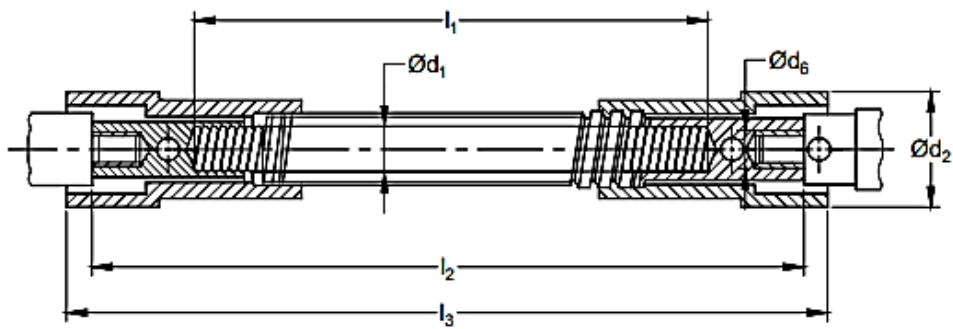
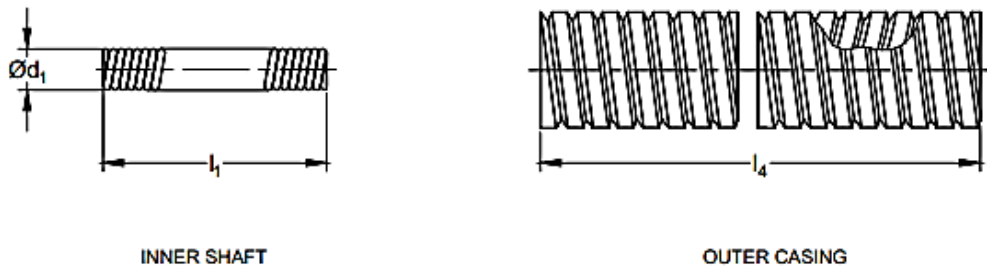
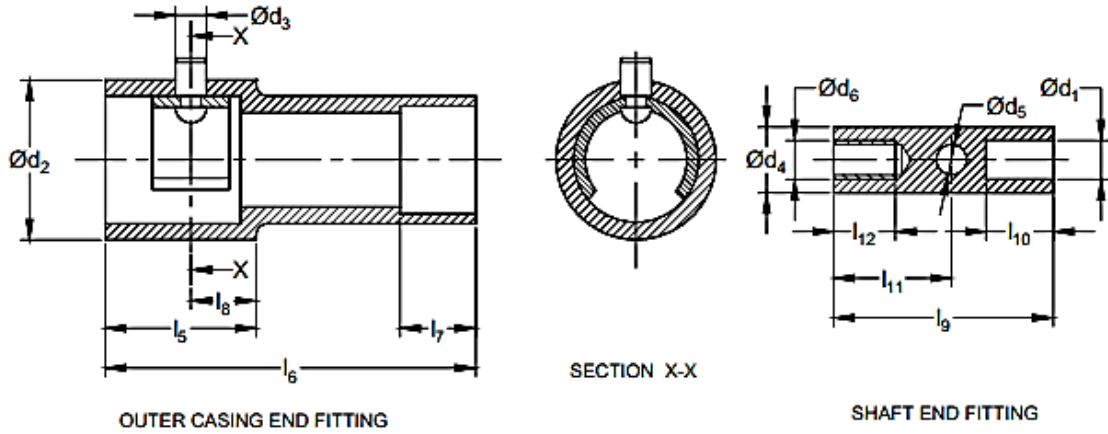

FLEXIBLE SHAFT ASSEMBLY

Table 2 (Concluded)

SI No.	Designation	d ₁	d ₂	d ₃	d ₄	d ₅	d ₆	L ₁	L ₂	L ₃	L ₄	L ₅	L ₆	L ₇	L ₈	L ₉	L ₁₀	L ₁₁	L ₁₂
(1)	(2)	(3)	(4)	(5)	(6)	(7)	(8)	(9)	(10)	(11)	(12)	(13)	(14)	(15)	(16)	(17)	(18)	(19)	(20)
i)	7 × 1 500	7	20	6	9	3	M6	1 500	—	—	1 470	40	133	36	13	35	10	19	12
ii)	7 × 2 000	7	20	6	9	3	M6	2 000	—	—	1 220	40	133	36	13	35	10	19	12
iii)	10 × 1 500	10	28	8	12	4.5	M10	1 500	1 570	1 610	1 460	40	133	36	13	50	15	27	17
iv)	10 × 2 000	10	26	8	12	4.5	M10	2 000	2 070	2 110	1 960	40	133	36	13	50	15	27	17
v)	12 × 1 500	12	28	8	14	4.5	M10	1 500	1 570	1 590	1 450	40	133	36	13	55	20	27	17
vi)	12 × 2 000	12	28	8	14	4.5	M10	2 000	2 070	2 090	1 950	40	133	36	13	55	20	27	17
vii)	13 × 2 000	13	34	8	18	6.5	M10	2 000	2 090	2 114	1 930	40	133	36	13	70	25	35	22
viii)	15 × 3 000	15	34	8	18	6.5	M10	3 000	3 090	3 114	2 930	40	133	36	13	70	25	35	22
ix)	20 × 2 000	20	40	8	23	6.5	M14	2 000	2 090	2 114	1 920	40	133	36	13	75	30	35	22
x)	20 × 3 000	20	40	8	23	6.5	M10	3 000	3 090	3 114	2 920	40	133	36	13	75	30	35	22

Table 3 Dimensions for Type B Flexile Shaft

[*Clause 5(b)*]

All dimensions are in millimeters.

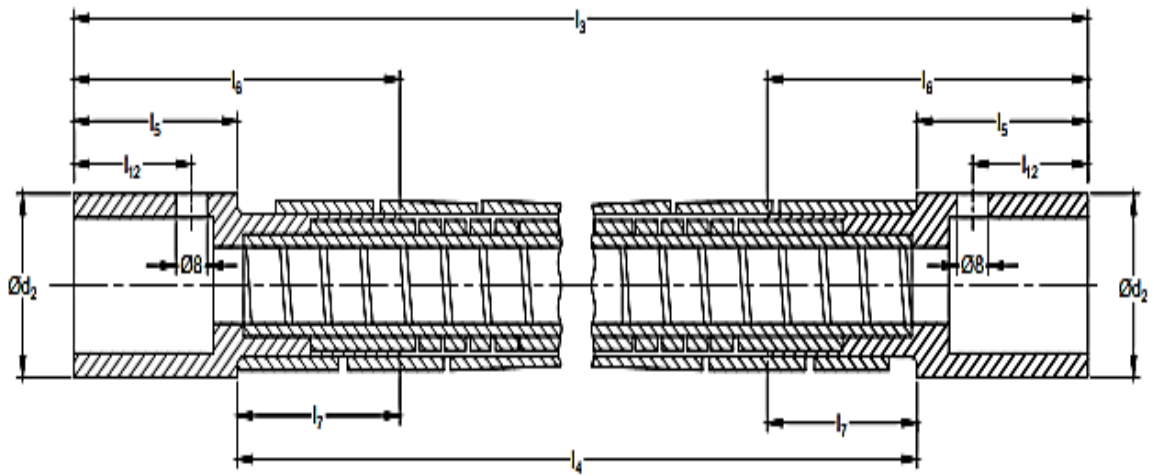

OUTER CASING ASSEMBLY

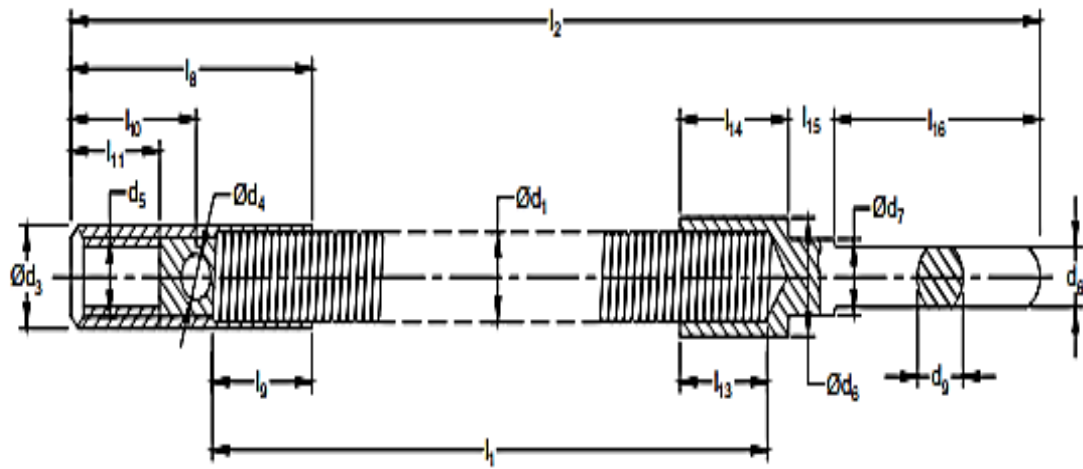

INNER SHAFT ASSEMBLY

Table 3 (Concluded)

Sl No.	Designation	d ₁	d ₂	d ₃	d ₄	d ₅	d ₆	d ₇	d ₈	d ₉	d ₁₀	d ₁₁	L ₁	L ₂	L ₃	L ₄	L ₅	L ₆	L ₇	L ₈	L ₉	L ₁₀	L ₁₁	L ₁₂	L ₁₃	L ₁₄	L ₁₅	L ₁₆	L ₁₇	L ₁₈	L ₁₉	L ₂₀
(1)	(2)	(3)	(4)	(5)	(6)	(7)	(8)	(9)	(10)	(11)	(12)	(13)	(14)	(15)	(16)	(17)	(18)	(19)	(20)	(21)	(22)	(23)	(24)	(25)	(26)	(27)	(28)	(29)	(30)	(31)	(32)	(33)
i)	7 × 1 500	7	30	8	120	5	M 10	22	8	8.5	5.0	3.9	1 500	1 590	1 547	1 452	30	86	33	10	40	11	24	18	75	31	33	20	15	20	38	18
ii)	7 × 2 000	7	30	8	120	5	M 10	22	8	8.5	5.0	3.9	2 000	2 090	2 047	1 952	30	96	33	10	40	11	24	18	75	31	33	20	15	20	38	18
iii)	10 × 1 500	10	30	8	120	5	M 10	28	8	12.5	7.5	5.9	1 500	1 605	1 548	1 436	30	102	40	10	47	15	25	18	90	40	40	28	20	23	52	18
iv)	10 × 2 000	10	30	8	120	5	M 10	28	8	14.0	7.5	5.9	2 000	2 105	2 048	1 936	30	102	40	10	47	15	25	18	90	40	40	28	20	23	52	18
v)	12 × 1 500	12	30	8	140	5	M 10	28	8	14.0	7.5	5.9	1 500	1 607	1 550	1 430	33	105	40	13	50	18	25	18	95	40	40	28	25	30	52	18
vi)	12 × 2 000	12	30	8	140	5	M 10	28	8	14.0	7.5	5.9	2 000	2 107	2 050	1 930	33	105	40	13	50	18	25	18	95	40	40	28	25	30	52	18
vii)	15 × 2 000	15	40	8	175	7	M 14	35	8	17.5	11.0	8.9	2 000	2 109	2 059	1 959	40	95	45	13	64	26	33	23	95	50	45	34	25	28	55	13
viii)	15 × 3 000	15	40	8	175	7	M 14	35	8	17.5	11.0	8.9	3 000	3 109	3 059	2 059	40	95	45	13	64	26	33	23	95	50	45	34	25	28	55	13
ix)	20 × 2 000	20	40	8	23.0	7	M 14	40	8	—	—	—	2 000	2 086	2 110	1 960	43	110	35	16	73	30	33	23	110	43	35	27	—	—	—	—
x)	20 × 3 000	20	40	8	23.0	7	M 14	40	8	—	—	—	3 000	3 086	3 110	2 960	43	110	35	16	73	30	33	23	110	43	35	27	—	—	—	—

NOTE — The dimensions given for 20 mm shaft are for the type where the shaft has a threaded (fixed) connection at both sides and not sliding at the tool holder.

6 DESIGNATION

Flexible shaft assembly shall be designated by the commonly known name, a letter 'L' or 'R' representing left lay or right lay of the outer layer of the inner shaft, by the diameter of the inner shaft, length of the inner shaft and the number of this standard.

Example:

A flexible shaft having left lay as the outer layer of the inner shaft with inner shaft diameter of 12 mm and length 2 000 mm shall be designated as:

Flexible shaft L 12 × 2 000 (IS 4600)

7 TESTS

7.1 Visual Inspection

The shaft shall be free from obvious flaws, kinks, bends, looseness, etc.

7.2 Roll Test

A length of about 1 000 mm or more is taken, and is laid on the floor in a slight curve of about 10 m diameter and rolled back and forth at the center by foot the shaft shall roll smoothly throughout its length without offering resistance and without jerking or flapping about. The extreme ends may flap a little.

7.3 Locking Diameter Test

The flexible shaft assembly is looped and the junction is held in hand. One end of the flexible shaft

is pulled, so as to reduce the diameter of the loop until the shaft assembly is felt to offer considerable resistance. The diameter of the loop is then measured. It shall be within 20 times the diameter of the inner shaft. The loop shall be as nearly circular as possible and there shall not be any obvious difference in the radius of curvature at two adjacent points.

8 MARKING

All the shafts shall be marked with the designation and manufacturer's name or trademark. Cartons or the packages for the shaft shall be marked with the following:

- a) Type and designation of the shaft;
- b) Length of shaft;
- c) Direction of shaft;
- d) Manufacturer's name or trade-mark; and
- e) Date of manufacturing.

9 BIS CERTIFICATION MARKING

The product(s) conforming to the requirements of this standard may be certified as per the conformity assessment schemes under the provisions of the *Bureau of Indian Standards Act, 2016* and the Rules and Regulations framed thereunder, and the product(s) may be marked with the Standard Mark.

10 PACKING

The flexible shaft shall be suitably packed to avoid damage during handling and transportation.

ANNEX A

(Foreword)

COMMITTEE COMPOSITION

Transmission Devices Sectional Committee, PGD 33

<i>Organization</i>	<i>Representative(s)</i>
Maruti Suzuki India Limited, Gurugram	SHRI VIKAS CHOPRA (<i>Chairperson</i>)
Elecon Engineering Company Limited, Anand	SHRI VRAJLAL SENJALIYA SHRI VILAS B. KALYAN (<i>Alternate</i>) SHRI PRAYASVIN B. PATEL (<i>Alternate II</i>)
Honda Motorcycle and Scooter India Private Limited, Gurugram	SHRI ARPAN SHUKLA
Indian Institute of Technology, Indore	SHRI NEELESH KUMAR JAIN DR P. P. CHATTARAJ (<i>Alternate I</i>) PROF I. A. PALANI (<i>Alternate II</i>)
Kirloskar Pneumatic Company Limited, Pune	SHRI KANNAN LOGANATHAN
Forech India Limited, Sonipat	SHRI I. K. BAHL SHRI TIMIR BHATTACHARYYA (<i>Alternate</i>)
LG Balakrishnan and Bros Limited, Coimbatore	SHRI PRABAKARAN P. SHRI SUBBIAH P. (<i>Alternate I</i>) SHRI PANNERSELVAN M. (<i>Alternate II</i>)
Lohia Corp Limited, Kanpur	SHRI PRAKASH KUMAR SHRI MAHENDRAN M. (<i>Alternate I</i>) SHRI DEV KANTH (<i>Alternate II</i>) SHRI AMIT JAISWAL (<i>Alternate III</i>)
Mahindra and Mahindra Limited, Mumbai	SHRI JIBIN K. PAUL
Maruti Suzuki India Limited, Gurugram	SHRI AMIT TALWAR SHRI GURURAJ RAVI (<i>Alternate</i>)
Research Designs and Standards Organization (RDSO), Lucknow	SHRI VJAY KUMAR GOEL SHRI C. K. BHATT (<i>Alternate I</i>) SHRI S. PANWAR (<i>Alternate II</i>)
Shanthi Gears Limited, Coimbatore	SHRI MUTHUMADHAVAN V.
Suzlon Energy Limited, New Delhi	SHRI MOHAMED NASEERUDDIN
TIDC India Limited, Chennai	SHRI B. SRINIVAS DR K. KRISHNA KUMAR
VE Commercial Vehicles Limited, Dewas	SHRI ARVIND MANOHAR SHRI MAHENDRAN MOHAN (<i>Alternate I</i>) SHRI SAPTHARISHI IYER (<i>Alternate II</i>)
In Personal Capacity (20/2, At Rabindra Nagar Near Sikshan Bhaban, West Midnapore)	SHRI ASHISH KUMAR KHANRA
In Personal Capacity (D-1, Kailashpuri Complex, Kusum Vihar. Phase-2, Koylanagar, Dhanbad)	SHRI K. K. S. SINHA

IS 4600 : 2024

BIS Directorate General

SHRI R. R. SINGH, SCIENTIST 'F'/SENIOR
DIRECTOR AND HEAD (PRODUCTION AND
GENERAL ENGINEERING) [REPRESENTING
DIRECTOR GENERAL (*Ex-officio*)]

Member Secretary

SHRI VICHITRA VIR SINGH
SCIENTIST 'D'/JOINT DIRECTOR
(PRODUCTION AND GENERAL ENGINEERING), BIS

Bureau of Indian Standards

BIS is a statutory institution established under the *Bureau of Indian Standards Act, 2016* to promote harmonious development of the activities of standardization, marking and quality certification of goods and attending to connected matters in the country.

Copyright

BIS has the copyright of all its publications. No part of these publications may be reproduced in any form without the prior permission in writing of BIS. This does not preclude the free use, in the course of implementing the standard, of necessary details, such as symbols and sizes, type or grade designations. Enquiries relating to copyright be addressed to the Head (Publication & Sales), BIS.

Review of Indian Standards

Amendments are issued to standards as the need arises on the basis of comments. Standards are also reviewed periodically; a standard along with amendments is reaffirmed when such review indicates that no changes are needed; if the review indicates that changes are needed, it is taken up for revision. Users of Indian Standards should ascertain that they are in possession of the latest amendments or edition by referring to the website-www.bis.gov.in or www.standardsbis.in.

This Indian Standard has been developed from Doc No.: PGD 33 (22814).

Amendments Issued Since Publication

Amend No.	Date of Issue	Text Affected

BUREAU OF INDIAN STANDARDS

Headquarters:

Manak Bhavan, 9 Bahadur Shah Zafar Marg, New Delhi 110002

Telephones: 2323 0131, 2323 3375, 2323 9402

Website: www.bis.gov.in

Regional Offices:

Central : 601/A, Konnectus Tower -1, 6th Floor,
DMRC Building, Bhavbhuti Marg, New
Delhi 110002

Telephones

{ 2323 7617

Eastern : 8th Floor, Plot No 7/7 & 7/8, CP Block, Sector V,
Salt Lake, Kolkata, West Bengal 700091

{ 2367 0012
2320 9474

Northern : Plot No. 4-A, Sector 27-B, Madhya Marg,
Chandigarh 160019

{ 265 9930

Southern : C.I.T. Campus, IV Cross Road, Taramani, Chennai 600113

{ 2254 1442
2254 1216

Western : Manakalya, 5th Floor/MTNL CETTM, Technology Street, Hiranandani Gardens, Powai
Mumbai 400076

{ 25700030
25702715

Branches : AHMEDABAD, BENGALURU, BHOPAL, BHUBANESHWAR, CHANDIGARH, CHENNAI, COIMBATORE, DEHRADUN, DELHI, FARIDABAD, GHAZIABAD, GUWAHATI, HARYANA (CHANDIGARH), HUBLI, HYDERABAD, JAIPUR, JAMMU, JAMSHEDPUR, KOCHI, KOLKATA, LUCKNOW, MADURAI, MUMBAI, NAGPUR, NOIDA, PARWANOO, PATNA, PUNE, RAIPUR, RAJKOT, SURAT, VIJAYAWADA.