

घरेलु प्रशीतन साधित्र — विशेषताएँ और  
परीक्षण पद्धतियाँ  
भाग 1 सामान्य अपेक्षाएँ  
( पहला पुनरीक्षण )

Household Refrigerating  
Appliances — Characteristics and  
Test Methods  
Part 1 General Requirements  
( First Revision )

ICS 97.030; 97.040.30

© BIS 2024



भारतीय मानक ब्यूरो  
BUREAU OF INDIAN STANDARDS  
मानक भवन, 9 बहादुर शाह ज़फर मार्ग, नई दिल्ली - 110002  
MANAK BHAVAN, 9 BAHADUR SHAH ZAFAR MARG  
NEW DELHI - 110002  
[www.bis.gov.in](http://www.bis.gov.in) [www.standardsbis.in](http://www.standardsbis.in)

## FOREWORD

This Indian Standard (Part 1) (First Revision) was adopted by the Bureau of Indian Standards, after the draft finalized by the Refrigeration and Air Conditioning Sectional Committee had been approved by the Mechanical Engineering Division Council.

This standard was first published in 2021.

The household refrigerating appliances, which are factory-assembled and cooled by internal natural convection including mechanical and absorption type (direct cool) or forced air circulation (frost-free) was earlier covered in two separate standards that is, IS 1476 (Part 1) and IS 15750 respectively.

In the light of the development taken place at the international level, the Committee had decided to make a composite standard on refrigerators to cover the requirements of both direct cool and frost-free refrigerators in IS 17550 (Part 1 to Part 3) published in 2021.

The standards were largely rewritten and updated to cope with new testing requirements, new product configurations, the advent of electronic product controls and computer-based test-room data collection, and processing equipment.

This standard is published in three parts. The other parts in this series are:

Part 2 Performance requirements

Part 3 Energy consumption and volume determination

The first revision has been brought out to keep pace with the latest technological developments and international practices. In this revision following major changes have been made:

- a) The scope has been revised;
- b) The terminologies have been further clarified;
- c) The opening sequence of external door for durability test has been revised;
- d) The requirement of the variable temperature compartments has been modified;
- e) The composition of test package has been revised;
- f) The requirement of M-packages has been modified;
- g) The location of sensors for determination of compartment average air temperatures have been revised; and
- h) Items that may be included in a test report have been revised (*see [Annex G](#)*).

This standard is based on IEC 62552-1 : 2015 issued by International Electrotechnical Commission (IEC) except for the following deviations:

- a) Only climate class T refrigerating appliances are covered in this standard;
- b) Following additional tests have been incorporated:
  - 1) Materials, design, and manufacture;
  - 2) Testing the air tightness of door or lid seal(s);
  - 3) Testing the opening force of door(s) or lid(s);
  - 4) Testing the durability of hinges and handles of door(s) and lid(s);
  - 5) Testing the mechanical strength of shelves and similar components;
  - 6) Water-vapour condensation test;

*(Continued on third cover)*

*Indian Standard*HOUSEHOLD REFRIGERATING APPLIANCES —  
CHARACTERISTICS AND TEST METHODS**PART 1 GENERAL REQUIREMENTS***( First Revision )***1 SCOPE**

**1.1** This Indian Standard (Part 1) specifies the essential characteristics of household and similar refrigerating appliances, cooled by internal natural convection or forced air circulation, their rated voltage not exceeding 250 V, 50 Hz a.c., and establishes test methods for checking the characteristics.

**1.2** The tests defined in this standard are meant to assess the fundamental design and operation of a refrigerating appliance.

NOTE — [Annex G](#) lists the items that can be included in a test report.

**1.3** For the verification of the performance of a refrigerating appliance of a given type it is preferable, wherever practicable, that all the tests specified are applied to a single unit. The tests can also be made individually for the study of a particular characteristic.

**1.4** Refrigerating appliances conforming to this standard are classified into T class instead of four climate class. The range of ambient temperatures in which the appliances are intended to be used, and for which the required storage temperatures are to be met is specified in [Table 1](#).

NOTE — The climate class in India is considered a T Class.

**1.5** This standard shall be read in conjunction with the requirements given in Part 2 and Part 3 of this standard.

**1.6** The requirement of ECO-Mark criteria is given in [Annex J](#) of this standard. The requirement of ECO-Mark is optional.

**2 REFERENCES**

The standards listed in [Annex A](#) contain provisions which, through reference in this text, constitute provisions of this standard. At the time of publication, the editions indicated were valid. All standards are subject to revision, and parties to agreements based on this standard are encouraged to investigate the possibility of applying the most recent edition of these standards.

**3 TERMINOLOGY AND SYMBOLS**

For the purpose of this standard, the following definitions shall apply.

**3.1 General Terms and Definitions**

**3.1.1 Refrigerating Appliance** — Insulated cabinet with one or more compartments that are controlled at specific temperatures and are of suitable size and equipped for household use, cooled by natural convection or a forced convection system whereby the cooling is obtained by one or more energy-consuming means.

NOTE — From the point of view of installation, there are various types of household refrigerating appliance (free-standing, wall-mounted, built-in, etc).

**3.1.2 Refrigerator** — Refrigerating appliances intended for the storage of foodstuff, with at least one fresh food compartment.

**3.1.3 Refrigerator-Freezer** — Refrigerating appliance having at least one fresh food compartment and at least one freezer compartment.

**3.1.4 Refrigerating Appliance Technology**

**3.1.4.1 Frost-free refrigerating appliance** — Refrigerated appliances in which all compartments are automatically defrosted with automatic disposal of the defrosted water and at least one compartment is cooled by a frost-free system.

**3.1.4.2 Direct cool refrigeration** — Refrigerated appliances in which cooling is provided by internal natural convection and the evaporator(s) is (are) defrosted by manual defrost.

**3.1.5 Freezer** — Refrigerating appliance with only frozen compartments, and at least one of which is a freezer compartment.

**3.1.6 Wine Storage Appliances** — Refrigerating appliance that has no compartment other than one or more wine storage compartment(s).

NOTE — An appliance containing any compartments which do not fulfil all requirements as specified for wine storage compartments under [Annex H](#) shall not be categorized as a wine storage appliance.

**3.1.7 Built-in Appliance** — Refrigerating appliances intended to be used whilst fastened in an enclosure or secured in a prepared recess in a wall or similar location.

**3.1.8 Foodstuff** — Food and beverages intended for consumption.

**3.1.9 Rated** — Value declared by the manufacturer (for example volume, energy consumption, usage etc).

**3.1.10 Normal Use** — Operation when the refrigerating appliance is subject to a range of different conditions that could occur during use including operation in a range of:

- a) Indoor temperature including those defined in the storage test specified in Part 2 of this standard;
- b) Different humidity levels; and
- c) User related actions, such as door openings which may be regular, infrequent, or a mixture there off and the additions and removal of foodstuff or other stored items.

## 3.2 Definitions Related to Refrigerating System

**3.2.1 Refrigerant** — Fluid used for heat transfer in a refrigerating system, which absorbs heat at a low temperature and at a low pressure of the fluid and rejects heat at a higher temperature and at a higher pressure of the fluid, usually involving changes of state of the fluid.

**3.2.2 Condenser** — Heat exchanger from which heat in the refrigerant is rejected to an external cooling medium (usually the air surrounding the appliance).

**3.2.3 Evaporator** — Heat exchanger which absorbs heat from the compartment to be refrigerated and transfers this to the refrigerant.

## 3.3 Compartments and Sections

**3.3.1 Compartment** — Enclosed space within a refrigerating appliance, which is directly accessible through one or more external doors, which may itself be divided into sub-compartments.

### NOTES

**1** The requirements for the compartment types are specified in Table 2 of IS 17550 (Part 2) and Table 1 of IS 17550 (Part 3).

**2** Throughout this standard, unless otherwise specified, 'compartment' shall be taken to mean compartment and/or sub-compartment as appropriate for the context.

**3** A non-enclosed space in the refrigerating appliance having one or more external doors, which are only used to access this space, is considered to be a compartment.

**3.3.2 Sub-compartment** — Permanent enclosed space within a compartment which has a different operating temperature range from the compartment within which it is located.

**3.3.3 Convenience Feature** — Enclosure, or a container (either fixed or removable by the user), in which suitable storage conditions are provided for designated types of foodstuff.

NOTE — These conditions may be different from those of the compartment in which it is located.

**3.3.4 Variable Temperature Compartment** — Compartment intended for use as two (or more) alternative compartment types, for example a compartment that can be either a fresh food compartment or freezer compartment and which is capable of being set by a user to continuously maintain the operating temperature range applicable for each compartment type claimed.

### NOTES

**1** A compartment intended for use as a single type but that can also meet additional types, for example, a chill compartment that may also fulfil zero-star requirements is not a variable temperature compartment.

**2** See [C-2.5.2](#) for requirements regarding energy consumption declarations for products with variable temperature compartments.

**3.3.5 Freezer Compartment** — Compartment that meets three-star or four-star requirements.

NOTE — Two-star sections and/or sub-compartments are permitted within the compartment.

**3.3.6 Fresh Food Compartment** — Compartment for the storage and preservation of unfrozen foodstuff.

**3.3.7 Cellar Compartment** — Compartment for the storage of foodstuff at a temperature that is warmer than that of a fresh food compartment.

**3.3.8 Pantry Compartment** — Compartment for the storage of foodstuff at a temperature that is warmer than that of a cellar compartment.

**3.3.9 Chill Compartment** — Compartment for the storage of highly perishable foodstuffs.

**3.3.10 Ice Making Compartment** — Compartment specifically for the making and storage of ice.

NOTE — An ice-making compartment is classified as a zero-star compartment or a frozen compartment.

**3.3.11 Ice-mould** — Form in an automated icemaker which is automatically filled with water and from which the ice cubes are manually ejected.

**3.3.12 Ice Cube Tray** — Removable tray which is manually filled with water and from which ice cubes are manually ejected.

**3.3.13 Zero Star Compartment** — Compartment in which the temperature is not warmer than 0 °C that can be used for the making and storage of ice but is not suitable for the preservation of highly perishable foodstuff.

**3.3.14 Wine Storage Compartment** — Compartment specifically for the storage and maturation of wine.

NOTE — Temperature requirements for wine storage compartment are specified in [Annex H](#).

**3.3.15 Unfrozen Compartment** — Any of the following compartment types: zero-star, chill, fresh food, cellar, wine storage, or pantry.

NOTE — Although ice making compartments and zero-star compartments operate below zero, they are configured as uniform compartments for energy and performance tests in this standard.

**3.3.16 Frozen Compartment** — Any of the following compartment types: one-star, two-star, three-star, four-star.

NOTE — Frozen compartments are classified according to temperature (see [3.3.16.1](#) to [3.3.16.4](#)).

**3.3.16.1 One-star** — Compartment where the storage temperature is not warmer than  $-6\text{ }^{\circ}\text{C}$ .

**3.3.16.2 Two-star** — Compartment where the storage temperature is not warmer than  $-12\text{ }^{\circ}\text{C}$ .

**3.3.16.3 Three-star** — Compartment where the storage temperature is not warmer than  $-18\text{ }^{\circ}\text{C}$ .

NOTE — Two-star sections and/or sub-compartments are permitted within the compartment.

**3.3.16.4 Four-star** — Compartment where the storage temperature meets three-star conditions and where the minimum freezing capacity meets the requirements of 8 of Part 2 of this standard.

#### NOTES

1 Two-star sections and/or sub-compartments are permitted within the compartment.

2 Any two-star section in the compartment shall not exceed 20 percent of the total compartment volume.

**3.3.17 Two-star Section** — Part of a three-star or four-star compartment, which is not self-contained, that is, which does not have its own individual access door or lid and which meets two-star requirements.

NOTE — Any two-star section in the compartment shall not exceed 20 percent of the total compartment volume.

**3.3.18 Vegetable Drawer or Crisper** — Convenience feature provided primarily to retard dehydration of fruits and vegetables.

NOTE — A vegetable drawer is usually considered as a removable convenience feature but is normally left in situ for testing purposes.

### 3.4 Physical Aspects and Dimensions

**3.4.1 Top-Opening Type** — Refrigerating appliance in which the compartment(s) are accessible from the top (usually via a lid).

**3.4.2 Upright Type** — Refrigerating appliance in which the compartment(s) are accessible from the front.

**3.4.3 Overall Dimensions** — Space taken up by the refrigerating appliance that is height, width, and depth with doors or lids closed.

**3.4.4 Space Required in Use** — Space taken up by the refrigerating appliance (height, width, and depth) necessary for normal use with doors or lids closed, including space necessary for air circulation and any handles as shown in [Fig. 5](#).

**3.4.5 Overall Space Required in Use** — Total space taken up by the refrigerating appliance (height, width, and depth) necessary for normal use with doors or lids open as shown in [Fig. 5](#).

**3.4.6 Volume** — Space within the inside liner of the refrigerating appliance, or a compartment or sub-compartment as determined in Part 3 of this standard.

**3.4.7 Shelf** — Horizontal surface on which foodstuff can be placed.

NOTE — A shelf can be formed by one component or by components fitted side by side, which can be fixed or removable.

**3.4.8 Load Limit** — Surface enveloping a storage space and intended for the storage of foodstuff or other items.

NOTE — A load limit may be a natural obvious feature or a marked line.

**3.4.9 Storage Plan** — Arrangement of test packages within a refrigerating appliance when testing specific aspects of performance in accordance with this standard.

**3.4.10 H-Line** — Vertical line through a compartment used to measure the effective height and to define the height positions of sensors in a compartment.

### 3.5 Terms and Definitions Related to Performance Characteristics

**3.5.1 Energy Consumption** — Energy used by a refrigerating appliance over a specified period of time or for a specified operation as determined in accordance with Part 3 of this standard and is measured in watt hours (Wh) or kilowatt hours (kWh).

**3.5.2 Average Power Consumption** — Average rate of energy consumption of a refrigerating appliance as determined in accordance with Part 3 of this standard and is measured in watts (W).

**3.5.3 Storage Temperature** — Temperature which the refrigerating appliance is capable of maintaining in accordance with the stipulation given in 6.5 of Part 2 of this standard.

**3.5.4 Target Temperature** — Reference compartment temperature which is used for determining energy and average power consumption defined in Part 3 of this standard.

NOTE — Target temperatures are air temperature as explained in [Annex E](#).

### 3.5.5 Defrosting

**3.5.5.1 Automatic defrost** — Defrosting where no action is necessary by the user to initiate the removal of frost accumulation at all temperature-control settings or to restore normal operation, and the disposal of the defrost water is automatic.

NOTE — Automatic defrost can be achieved by active heating of the evaporator (typically using a resistive heater) or by other means, such as stopping the cooling function of the evaporator without active heating, reverse cycle defrost, or hot gas bypass defrosting.

**3.5.5.2 Manual defrost** — Defrosting that is not an automatic defrost.

**3.5.5.3 Cyclic defrost** — Automatic defrost system where the refrigerated surfaces which cool a compartment, usually an unfrozen compartment in an appliance, are automatically defrosted and defrosting occurs during each cycle of the refrigeration system.

NOTE — Cyclic defrost systems do not have a defrost control cycle.

**3.5.5.4 Variable defrost** — Automatic defrost system designed to minimize energy consumption which adjusts the time intervals between successive defrosts under normal use to better match the actual frost load on the evaporator by assessment of an operating condition or conditions other than, or in addition to, elapsed time or compressor run time.

NOTE — Demand defrost, (directly measuring the frost on the evaporator and defrosting accordingly) is a form of variable defrost.

**3.5.6 Stable Operating Conditions** — Conditions in which a refrigerating appliance mean temperatures and energy consumption comply with the relevant stability requirements as defined in Part 2 or Part 3 of this standard as applicable.

**3.5.7 Steady State** — Stable operating conditions that meet the criteria as specified in Annex C of Part 3 of this standard.

**3.5.8 Ambient Temperature** — Measured temperature in the space surrounding the refrigerating appliance under test.

NOTE — The ambient temperature for each test type is measured as specified in [Annex B](#) of this part and its value is as specified in Part 2 and Part 3 of this standard as applicable for the particular test.

**3.5.9 Control Event** — A change in the operating conditions which include but are not limited to:

- a) Starts, stops, or speed changes of compressors;
- b) Changes of baffle position, fan operation, or other modulating control or device;
- c) Changes in operation of the refrigerant circuit;
- d) Defrost heater on and off; and

e) Icemaker operation.

**3.5.10 Frost Free** — Automatic defrost system to prevent the permanent formation of frost on a remote evaporator or evaporators.

**3.5.11 Temperature Control** — Device that is intended to automatically regulate the temperature within one or more compartments.

**3.5.12 User-Adjustable Temperature Control** — Temperature control intended for adjustment by the user to vary the temperature within one or more compartments within a refrigerating appliance.

**3.5.13 Temperature Control Setting** — Setting of a user adjustable temperature control selected for the measurement of energy or performance in accordance with this standard.

**3.5.14 Cooling Time** — Time taken for a specified load in a fresh food compartment to be cooled as defined in 7 of Part 2 of this standard.

**3.5.15 Cooling Capacity** — Rate at which a specified load in a fresh food compartment can be cooled as defined in 7 of Part 2 of this standard.

**3.5.16 Freezing Time** — Time to freeze in a freezer or freezer compartment a set amount of load as defined in 8 of Part 2 of this standard.

**3.5.17 Freezing Capacity** — Rate of heat extraction by the refrigeration system from a load in a freezer or freezer compartment as defined in 8 of Part 2 of this standard.

**3.5.18 Ice Making Capacity** — Quantity of ice the refrigerating appliance is capable of producing in an automatic icemaker in accordance with 9 of Part 2 of this standard.

**3.5.19 Temperature Rise Time** — Time taken, after the operation of the refrigerated system has been interrupted, for the temperature to increase a defined amount when tested as specified in Annex C of Part 2 of this standard.

**3.5.20 Ballast Load** — Combination of test and M-packages already at storage temperature and in the freezer or freezer compartment when the light load is added during the freezing capacity tests.

**3.5.21 Light Load** — Combination of test and M-packages at ambient temperature that are loaded into a freezer compartment during the freezing capacity test.

**3.5.22 Load Processing Efficiency Test** — Test in which a specified water load is introduced to the appliance to determine how much extra energy is needed to cool it down (and, in a frozen compartment, freeze it).

NOTE — See Annex G of Part 3 of this standard.



**3.5.23 Processing Load** — Energy equivalent of a user processing load in Wh/day.

**3.5.24 Load Processing Efficiency** — Ratio of additional energy used by the refrigerating appliance to cool a specified processing load to the calculated heat energy removed from that processing load.

### 3.6 Operating States (See [Fig. 1](#))

**3.6.1 Temperature Control Cycle** — Definite repetitive swings in temperature caused by operation of a temperature control device (on/off or otherwise).

**3.6.2 Defrost Control Cycle** — Period commencing at the end of stable operating conditions prior to the initiation of an automatic defrost and terminating at a like point prior to the next automatic defrost.

#### NOTES

1 The commencement and finish points of the defrost control cycle prior to automatic defrosting shall be:

- For a refrigerating system with on/off cycles, the period commencing at the end of the last regular temperature control cycle, for example the end of last off period;
- For a refrigerating system without on/off cycles but with regular temperature cycles, at the last power/speed/cooling change that relates to a regular temperature maximum; and
- For a refrigerating system without on/off cycles and without regular temperature cycles, at the end of stable temperature operation.

2 Cyclic defrost systems do not have a defrost control cycle.

**3.6.3 Defrosting Operation** — Period from the initiation of a defrost control cycle until the initiation of the refrigeration system cooling after defrosting.

**3.6.4 Defrost and Recovery Period** — Period from the initiation of a defrost control cycle until stable operating conditions are established.

NOTE — For products that do not reach operating conditions for example that have a temperature that is continually decreasing after a defrosting operation, the defrost and recovery period could be equal to the defrost control cycle.

**3.6.5 Recovery Period** — Period from the end of the defrosting operation until the end of the defrost and recovery period.

**3.7 Symbols** — For the purpose of this standard, the following letter symbols have the meaning indicated against each, other symbols used in this standard have been explained at appropriate places.

TMP	—	Temperature measurement point
T	—	Temperature
t	—	Time
i	—	Subscript representing a certain sensor location

NOTE — Components of refrigerator operation depicted in this figure are illustrative only and are intended to be representative of common products. Not all products exhibit all the features, and some products can operate in a different manner. Written definitions have precedence over depictions in this [Fig. 1](#).

**3.8 Temperature Classification** — The temperature classification for refrigeration appliances are defined as SN, N, ST, and T as per the temperature ranges given below for each class:

- SN (Subnormal/Extended temperate) suitable for use under ambient temperature range of 10 °C to 32 °C;
- N (Normal) suitable for use under ambient temperature range of 16 °C to 32 °C;
- ST (Subtropical) suitable for use under ambient temperature range of 16 °C to 38 °C; and
- T (Tropical) suitable for use under ambient temperature range of 16 °C to 43 °C.

NOTE — These abbreviations are conventional because they are regulated by international standards for the refrigeration equipment and do not depend on a market or a country of production.

## 4 CLASSIFICATION

Refrigerating appliances conforming to this standard are classified into one (or more) of four climate classes. The range of ambient temperatures in which the appliances are intended to be used, and for which the required storage temperatures are to be met [see Table 2 of IS 17550 (Part 2)], shall be as specified in [Table 1](#).

## 5 MARKING

### 5.1 Rating Information

The following information shall be marked in a permanent and legible manner on the appliance:

- Manufacturer's name or trademark, or brand or identification mark;
- Type of refrigerating appliance (for example, 'refrigerator', with the designation being prefixed by the term 'frost-free' if applicable);
- Serial number and/or date of manufacture, which may be coded;
- Total volume (alternatively, the volume for each compartment type may be listed);
- Country of manufacture/origin;
- Designation and mass, in gram, of the refrigerant (see IS 16656);
- Information relating to the energy source; and
- Letters indicating the climatic class or classes (SN, N, ST, T).

Items (a) to (h) should be visible when the refrigerating appliance is in its position of normal use. Other markings should either be readily visible in normal use or when the refrigerating appliance is away from a wall or after the

removal, without any tool, of a flap or grille, etc. Climate classes that are wholly covered by other climate classes do not need to be noted.

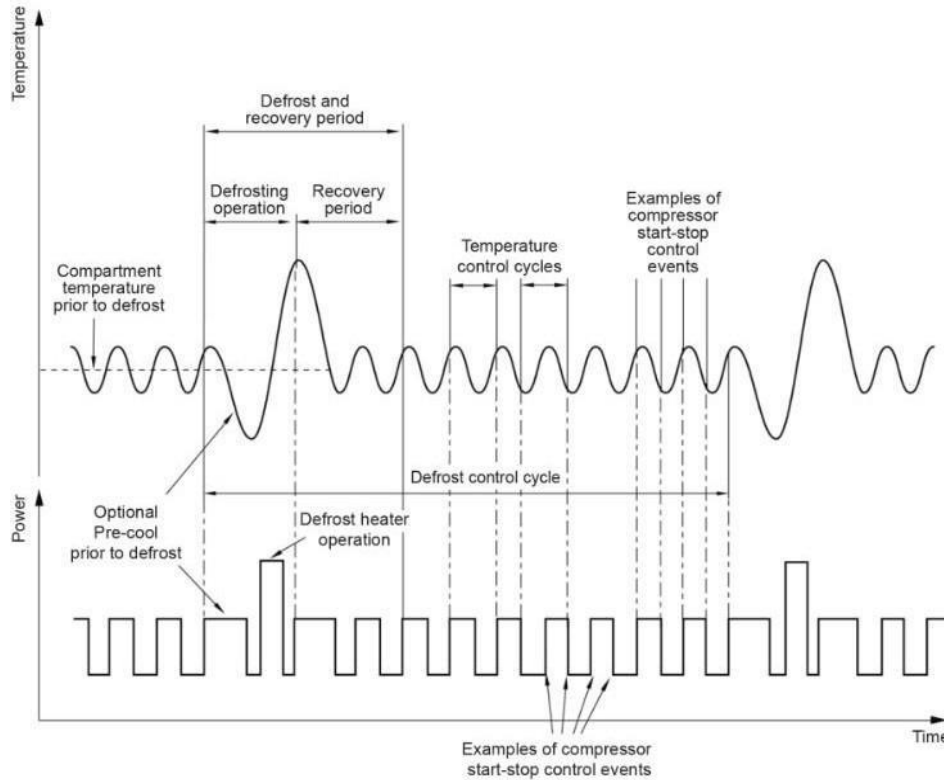

SI No.	Requirement	Instantaneous Temperature Value	Integrated Time Average Temperature <sup>1)</sup>	Instantaneous Average Compartment Temperature <sup>2)</sup>	Time Averaged Compartment Temperature <sup>3)</sup>	Maximum Compartment Temperature <sup>4)</sup>
(1)	(2)	(3)	(4)	(5)	(6)	(7)
i)	Fresh food	$T_i$	$T_{im}$	$T_a$	$T_{ma}$	—
ii)	Frozen food ( <i>f</i> )	$T_{fi}$	$T_{fim}$	$T_{fa}$	$T_{fma}$	$T^{***}, T^{**}, T^*$
iii)	Zero star ( <i>z</i> )	$T_{zi}$	$T_{zim}$	$T_{za}$	$T_{zma}$	—
iv)	Pantry ( <i>p</i> )	$T_{pi}$	$T_{pim}$	$T_{pa}$	$T_{pma}$	—
v)	Cellar ( <i>c</i> )	$T_{ci}$	$T_{cim}$	$T_{ca}$	$T_{cma}$	—
vi)	Chill ( <i>cc</i> )	$T_{cci}$	$T_{ccim}$	$T_{cca}$	$T_{ccma}$	—
vii)	Wine ( <i>w</i> )	$T_{wi}$	$T_{wim}$	$T_{wa}$	$T_{wma}$	—
viii)	Ambient ( <i>a</i> )	$T_{ai}$	$T_{aim}$	$T_{aa}$	$T_{ama}$	—

FIG. 1 ILLUSTRATION OF SELECTED TYPICAL REFRIGERATOR OPERATIONS

<sup>1)</sup> The integrated time average temperature is obtained by integrating the instantaneous temperature values over time and dividing it by the time period.

<sup>2)</sup> The instantaneous average compartment temperature is the arithmetic average of all instantaneous temperature values measured in the compartment at one time.

<sup>3)</sup> The time averaged compartment temperature is the integrated time average of the instantaneous average compartment temperature or the arithmetic average of the integrated time averaged temperatures (both methods give the same result).

<sup>4)</sup> The maximum compartment temperature is the maximum temperature of any M-package during the test period (for performance requirements, see Part 2 of this standard).

T\*\*\*.....defines the maximum compartment temperature for 3-star compartment.

T\*\* \_\_\_ defines the maximum compartment temperature for 2-star compartment.

T\* \_\_\_ defines the maximum compartment temperature for 1-star compartment.

So, No need to put in footnote as these stars are symbols.



**Table 1 Climate Classes**(Clauses [1.4](#) and [4](#))

Sl No.	Description	Class	Ambient Temperature Range °C
(1)	(2)	(3)	(4)
i)	Extended temperate	SN	+ 10 to + 32
ii)	Temperate	N	+ 16 to + 32
iii)	Subtropical	ST	+ 16 to + 38
iv)	Tropical	T	+ 16 to + 43

## 5.2 Identification of Frozen Compartments

When identified, four-star compartments shall be identified by a symbol readily visible from the front, externally or internally, in accordance with that shown in [Fig. 2](#).

Additionally, in the case of a two-star section in an identified freezer compartment, the standard two-star symbol (see [Fig. 3](#)) shall be placed to clearly indicate this section.

When identified, one, two, or three-star frozen compartments or cabinets shall be identified by a symbol as shown in [Fig. 3](#), readily visible from the front,

internally. In the case of a two-star section in an identified three-star or four-star compartment, the two-star symbol shall be located so that it clearly identifies the two-star section.

The symbols shown in [Fig. 2](#) and [Fig. 3](#) shall not make use of more than two colours or exhibit more than two contrasting surface finishes. The colour (or surface finish) of the large star shall be different from that of the three other stars. For the purpose of this requirement, white and black are considered as colours. There shall be no marking or decoration anywhere on the refrigerating appliance which could be confused with the four-star compartment identification symbol shown in [Fig. 2](#).

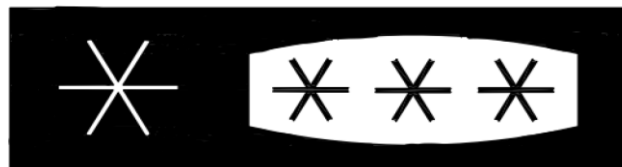

(For further details, see [Fig. 20](#)) (see [Annex F](#))

FIG. 2 IDENTIFICATION SYMBOL FOR A FOUR-STAR COMPARTMENT



### Key

- 1 One-star compartment symbol
- 2 Two-star compartment symbol
- 3 Three-star compartment symbol

(For further details, see [Fig. 21](#)) (see [Annex F](#))

FIG. 3 STAR IDENTIFICATION SYMBOLS FOR FROZEN COMPARTMENTS (EXCEPT FOUR-STAR)

**5.3 Load Limit Lines**

Load limit lines are permitted only in relation to freezer volumes and three-star frozen storage space in cabinets or compartments with an independent external door.

No load-limit line is necessary within the space of any cabinet or compartment suitable for three-star storage if:

- a) No space is acknowledged as being unsuitable for three or four-star storage;
- b) The load limits are determined by the particular construction (baskets, containers, flaps, etc); and
- c) The load limits are determined by natural load limits (see Fig 2B given in Part 2 of this standard) and the loading conditions are specially described in the instructions.

In all other cases, the limits of three or four-star storage space shall be indicated in a conspicuous and permanent way by a load-limit line or lines in the form shown in Fig. 4.

The manufacturer should avoid, as far as possible, the provision of storage spaces outside the load limits and outside any two-star compartment or sections.

**5.4 BIS Certification Marking**

The product(s) conforming to the requirements of this standard may be certified as per the conformity assessment schemes under the provisions of the Bureau of Indian Standards Act, 2016 and the Rules and Regulations framed thereunder, and the product(s) may be marked with the Standard Mark.

**5.5 ECO Mark**

The product conforming to the requirements of this standard (Part 1) may be marked with an ECO-Mark

provided it meets all the requirements given in Annex J of this standard (Part 1).

**6 TECHNICAL AND COMMERCIAL PRODUCT INFORMATION**

**6.1 General**

Whenever technical and commercial product information is supplied, all declared performance data (together with the relevant measurement units) shall be in accordance with this standard.

**6.2 Determination of Linear Dimensions**

Linear dimensions shall be measured to the nearest millimetre.

The overall dimensions shall be measured as the height, width, and depth of the rectangular parallelepiped, whose base is horizontal, within which the refrigerating appliance is inscribed to include the complete appliance except for the handle, the protrusion of which, if any, is to be specified separately (see Fig. 5). The height shall exclude the feet if these are fitted at the time of installation.

The space required in use shall be measured as the height, width, and depth, including the handle, increased by the space necessary for free circulation of the cooling air when the refrigerating appliance is in service (see Fig. 5).

The overall space required in use shall be measured as the height, width, and depth, including the handle, increased by the space necessary for free circulation of the cooling air when the refrigerating appliance is in service, plus the space necessary to allow the opening of the means of access to that minimum angle permitting removal of all removable parts such as containers and shelves, including a drip tray that has to be removed and any water container that has to be emptied manually (see Fig. 5).

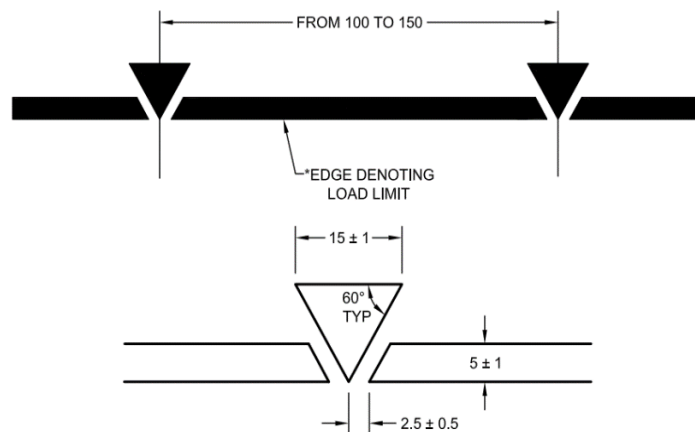

All dimensions in millimetres.  
FIG. 4 MARKING OF LOAD LIMIT

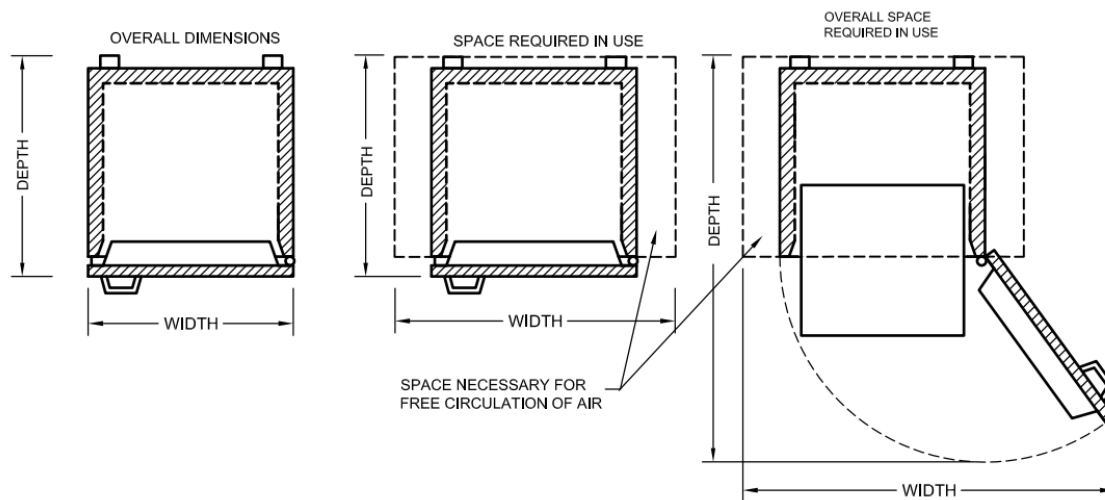

FIG. 5 LINEAR DIMENSIONS (EXAMPLE: TOP VIEW FOR UPRIGHT TYPE)

## 7 INSTRUCTIONS

Every refrigerating appliance shall be accompanied on delivery by instructions for its installation, use, user maintenance, and safe disposal.

Instructions should include the following where applicable:

- a) The installation requirements (best location, levelling, connections to energy source, connection – if required – for water supply or for defrost water);
- b) The space required in use and the overall space required in use with sketches showing the refrigerating appliance dimensions and minimum clearances required with the means of access (open and closed);
- c) For a refrigerating appliance which is intended to be built-in, the recess dimensions together with any additional ventilation requirements;
- d) The limit values of the range of ambient temperature for the rated climate classes and a warning that if the refrigerator operates outside the climate class (ambient temperature range) for which it is rated then it may not be able to maintain satisfactory internal temperatures;
- e) Operating instructions (starting and stopping procedures, use of the various controls – temperature-control devices, fast-freeze switch, indicator lights, air circulation and defrosting control, water and ice dispensers etc);
- f) The care required for best performance, such as:
  - 1) Loading the refrigerating appliance, especially when there are sections with different star ratings within the same compartment and when no load-limit lines exist;
  - 2) The arrangement of food for storage, in particular the need to avoid cross-contamination;
  - 3) The arrangement of food for storage and for freezing, where applicable, particularly including advice that food to be frozen is not to be placed in direct contact with food in storage and, if appropriate, that it could be necessary to reduce the quantity to be frozen if freezing every day is anticipated;
  - 4) In the case of refrigerating appliances with chill compartment, a statement to the effect that some types of fresh vegetables and fruits are sensitive to cold, and that therefore they are not suitable for storage in this kind of compartment; and
  - 5) The placing of ice-cube tray(s) in order to achieve optimal ice-freezing.
- g) The user maintenance and cleaning of the refrigerating appliance;
- h) For manual defrost products, any precautions with respect to defrosting and damage to stored food during this process;
- j) The action to be taken when the refrigerating appliance is switched off and taken out of service temporarily or for an extended period (examples, emptied, cleaned, and dried and the door(s) or lid(s) propped ajar);
- k) The necessity that, for doors or lids fitted with locks and keys, the keys be kept out of the reach of children and not in the vicinity of the refrigerating appliance, in order to prevent children from being locked inside;

- m) Removal of doors and lids on disposal to prevent entrapment; and
- n) Recovery of refrigerant and recycling of components on disposal of the refrigerating appliance.

## 8 MATERIALS, DESIGN, AND MANUFACTURE

### 8.1 General

Appliances shall be constructed in such a manner as to ensure adequate performance and durability in use. Their performance in use is checked by applying a series of relevant tests. This clause defines some characteristics which are not tested but to which the attention of the manufacturer is drawn.

### 8.2 Materials and Finishes

Materials used inside appliances shall not transmit odours or taste to food. When tested in accordance with [15](#), the mean value of the individual results during each evaluation for odour and taste shall not exceed mark 1. Materials used inside appliances shall not contaminate food placed in contact with them nor transmit poisonous substances to food. They shall be resistant to the action of moisture and food acids.

All surface finishes shall, for the purpose intended, be resistant to impact, sufficiently hard, colourfast, smooth, easily washable, and resistant to damage by moisture and by food acids.

### 8.3 Thermal Insulation and Air Tightness

The thermal insulation of the appliance should be efficient and permanently maintained. In particular, the insulating material shall not be subject to shrinkage and shall not allow, under normal working conditions, an excessive accumulation of moisture.

No running water shall appear externally when the appliance is subjected to the water vapour condensation test (see [13](#); and Annex D of Part 2 of this standard).

When the door or lid is closed, there shall be no abnormal ingress of air into the interior.

A strip of paper shall not slide freely when door or lid seals are subjected to the air tightness test specified in [9](#).

### 8.4 Doors, Lids, and Fittings

Hinges and handles shall be strong and resistant to corrosion.

External doors and lids of fresh food storage compartments and chill compartments cellar compartments shall withstand 10 000 openings and closings without deterioration which may be prejudicial to the air tightness of the appliance when subjected to the durability test specified in [11](#).

In the case of frozen food storage cabinets, food freezers, and appliances with the food freezer compartment and the frozen food storage compartment, if any, having a separate access door or lid, the hinges and handles of the door or lid of that compartment (or cabinet) shall withstand 10 000 openings and closings.

The fastening system shall be such as to enable the door or lid to be easily closed and opened. It shall be efficient and capable of maintaining its proper function.

For appliances having any compartment or section with a volume equal to or greater than 60 litre, it shall be possible to open the door or lid of that compartment from the inside with a force not exceeding 70 N when subjected to the test specified in [10](#). The volume of any compartment (or cabinet) or section shall be determined when all shelves, partitions, and other internal components removable without the aid of a tool have been removed.

### 8.5 Shelves and Containers

Shelves, containers, and similar components shall have adequate mechanical strength. Those used for storing food shall withstand the loading test specified in [12](#) without showing such distortion that they could no longer fulfil their intended function. In particular, sliding, or revolving components shall be capable of their full movement when loaded.

Shelves, containers, and similar components which are intended to be removable should be easily removable.

### 8.6 Disposal of Defrost Water

A means shall be provided for completely collecting the defrost water in an external receptacle wherein the defrost water is evaporated.

The defrost water receptacle should have adequate volume and should have adequate evaporating means.

Any drainage system shall be designed to ensure its proper function. It shall be easily accessible for the clearing of any blockage, and shall be designed so as to prevent any undue ingress of air into the food storage compartment(s) (or cabinets).

### 8.7 Refrigerating System

**8.7.1** The mechanical operation of the appliance should not give rise to undue noise or vibration.

**8.7.2** The design of the condenser should be such as to reduce to a minimum the accumulation of dust.

**8.7.3** The evaporator shall be so designed or protected so that it will not suffer any damage during the normal use of the appliance.

The heat exchange surfaces shall be made of corrosion-resistant material, or shall be finished with a corrosion-proof, non-poisonous coating, resistant to temperature changes and alternating frosting and defrosting.

**8.7.4** The means of adjustment of temperature control devices, if intended to be adjusted by the user, should be readily accessible, and their function shall be, such as to enable the appliance to meet the requirements of the performance tests.

**8.7.5** Pipes and connections to moving or resiliently mounted parts should be arranged so as not to generate noise, not to touch nor to transmit vibrations to other parts, and should be so designed as to prevent failure due to fatigue. All other pipes and connections should be securely anchored, where necessary.

**8.7.6** Suitable means should be provided to prevent water condensed on cold parts from affecting the operation of the unit or its controls, or from causing any other damage to the appliance and its surroundings.

### 8.8 Supply Cord

The length of the supply cord shall be at least 1.5 m when measured from the entry point of the refrigerator to the point of entry of the cord into the plug. It shall conform to IS 694.

### 8.9 Compressor

The compressor shall comply with IS 10617.

### 8.10 Temperature Sensing Controls (Thermostat)

The temperature sensing controls shall comply with IS/IEC 60730-2-9.

### 8.11 Temperature Sensing Controls (Thermostat) Setting

The temperature sensing controls (thermostat) setting should be such that when set at any one point, it should not cut-in before the system is balanced under any operating conditions.

### 8.12 Ice Cube Tray

The ice cube tray shall be made of food grade plastic or similar material as per relevant Indian Standards.

## 9 TESTING THE AIR TIGHTNESS OF DOOR OR LID SEAL(S)

**9.1** The purpose of this test is to ensure that the gasket(s) of the door(s) or lid(s) of the appliance adequately prevent(s) any abnormal ingress of the surrounding air.

### 9.2 Procedure

The ambient temperature shall be between + 16 °C and + 43 °C. The appliance shall be switched off and shall be in equilibrium with the ambient temperature before carrying out the test.

A strip of paper 50 mm wide and 0.08 mm thick and of suitable length shall be inserted at any point of the seal, and the door or lid shall be closed normally on it. The verification of the thickness of the paper used shall be in accordance with IS 1060 (Part 1).

The seal shall be assessed by checking that the strip of paper does not slide freely.

The most unfavourable points may be found by inspecting the area around the seal with the appliance closed and illuminated from the inside. This test shall be carried out both before and after the mechanical durability test (*see* [11](#)).

### 9.3 Test Report

The test report shall indicate whether the tightness of the door or lid seal(s) meets the requirements of [8.3](#).

## 10 TESTING THE OPENING FORCE OF DOOR(S) OR LID(S)

The purpose of this test is to check that the door(s) or lid(s) can be opened from the inside. Compliance shall be checked by inspection and by the following test.

### 10.1 Procedure

The ambient temperature shall be between + 16 °C and + 43 °C. The appliance shall be switched off and be in equilibrium with the ambient temperature. The door or lid shall be closed for a period of 1 h, after which an 'opening' test shall be carried out under the following conditions:

The opening force of 70 N shall be considered as being applied to the inside of the door or lid of the appliance at the midpoint of the edge furthest from the hinge axis in a direction perpendicular to the plane of the door or lid.

The method of measurement shall be one of the following:

- a) By applying the force at a point on the outer surface of the door or lid corresponding to the internal measuring point (for example, with the aid of a suction pad); and
- b) If the handle of the door or lid is at the midpoint of the edge farthest from the hinge axis, by applying a force to the handle, the value of the force required to open the door or lid from the inside being determined by proportional calculation from the distances of the handle and of the internal measuring point from the hinge axis.

This test shall be carried out both before and after the mechanical durability test (*see* [11](#)).

**10.2** The test report shall indicate whether the opening force of the door(s) or lid(s) meets the requirements of [8.4](#).

## 11 TESTING THE DURABILITY OF HINGES AND HANDLES OF DOOR(S) AND LID(S)

The purpose of this test is to check the durability of the hinges and handles of door(s) and lid(s).

### 11.1 External Door(s)

#### 11.1.1 Test Conditions/Preparation

The ambient temperature shall be between + 16 °C and + 43 °C. The appliance shall be switched off. The inner door(s) shall be loaded as specified in [12.1.2](#). The door shall be opened at least 45° from the cabinet reference wall before it starts closing.

##### 11.1.1.1 Opening sequence (see [Fig. 6](#))

The movement of the door shall be controlled from an angle of 0° to an angle of opening between 5° and 45°, without applying any appreciable jerk. The opening of the door shall take place in the first quarter of the period of the cycle.

##### 11.1.1.2 Closing sequence (see [Fig. 6](#))

The movement of the door shall be controlled from the angle of opening of 45° to an angle between 40° and 35°,

followed by the free movement of the door and its closing as in normal use.

The number of cycles per minute shall be 10 to 25.

- a) For compartments with an internal temperature  $T > - 6 \text{ °C}$ , external doors and lids shall withstand 100 000 opening and closing operations without deterioration which could be prejudicial to the air tightness of the door or lid; and
- b) For compartments with an internal temperature  $T \leq - 6 \text{ °C}$ , external doors and lids shall withstand 30 000 opening and closing operations without deterioration, which could be prejudicial to the air tightness of the door or lid.

### 11.2 Test Report

The test report shall also indicate whether the hinges and handles meet the requirements of [8.4](#) and whether the seals meet the requirements of [8.3](#). At the end of the test, there shall be no visible damage to the hinge, doors, or lids of refrigerator/refrigerator compartments.

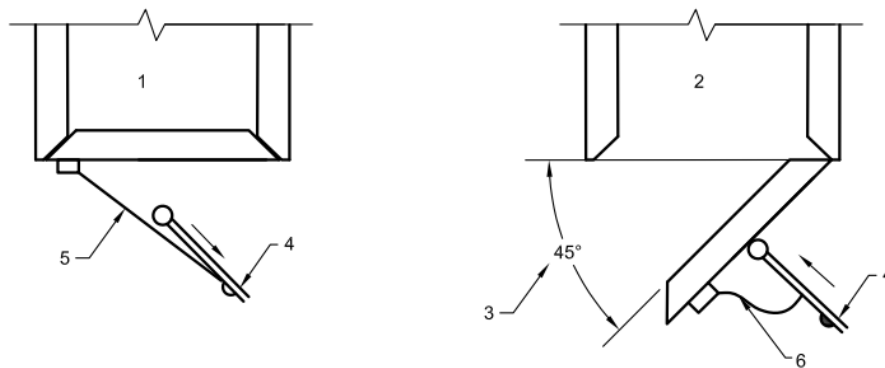

#### Key

- 1 Door Opening
- 2 Door Closing
- 3 Angle of Opening
- 4 Pusher
- 5 Taut Cable
- 6 Slack Cable

FIG. 6 EXAMPLE OF OPENING AND CLOSING OF EXTERNAL DOORS



## 12 TESTING THE MECHANICAL STRENGTH OF SHELVES AND SIMILAR COMPONENTS

The purpose of this test is to check the mechanical strength of the components used for storing food (shelves, containers) (see 8.5).

### 12.1 Procedure

The ambient temperature shall be between + 16 °C and + 43 °C.

#### 12.1.1 Food Freezer Compartment (or Cabinet), Frozen Food Storage Cabinet and Low Temperature Compartments (if Applicable)

After the storage test (see 6 of Part 2 of this standard), and with the appliance switched off, the behaviour of all loaded shelves, baskets, and containers and their supports shall be examined.

All sliding or revolving shelves and containers shall be moved, without modification of their load, to the halfway position,  $A/2$ , of their permissible course (see Fig. 7), except that if stops are provided which limit the movement to less than the half-way position the components shall be moved to their stop. They shall be left in this position for 1 h then returned to their initial position.

If the manufacturer has stated in the instructions for use that some shelves or containers slide out for maintenance or transportation, but must remain in a definite position in normal use, they shall be considered as fixed and the checking shall be carried out in the position as for the storage test.

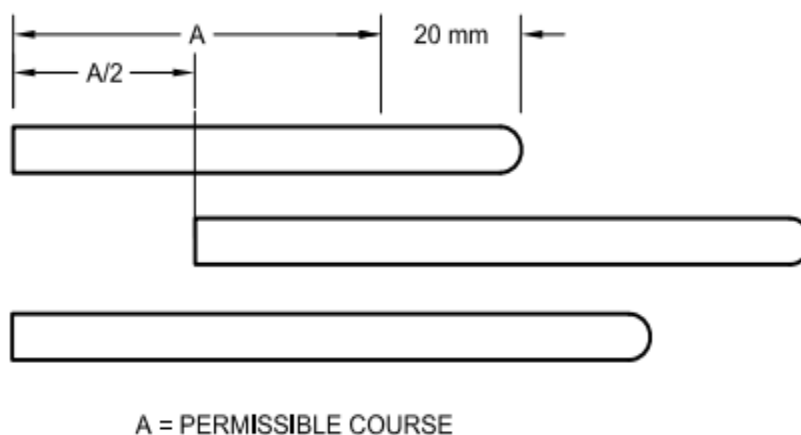

FIG. 7 TEST POSITION FOR SLIDING COMPONENTS WHICH HAVE NO LIMITING STOP

#### 12.1.2 Fresh Food Storage, Chill and Cellar Compartments (if Applicable)

The appliance shall be switched off, with the door(s) open.

The components to be tested shall be loaded in turn with 80 mm diameter cylindrical weights of 1 000 g, but of only 500 g in the case of components above which the clear height in normal service cannot exceed 150 mm. Components that are specially designed to hold eggs shall not be loaded.

The weights shall be placed with their axes vertical and in such a way that the maximum possible number is accommodated without one weight being placed over another and without overlapping the edge of the component under test.

In the case of door shelves, the diameter of the weights may be changed, if necessary, to adapt them to the shape of the shelves, provided the load per unit area is the same.

The applied loads shall remain in position for 1 h.

## 13 WATER VAPOUR CONDENSATION TEST

The purpose of this test is to determine the extent of condensation of water on the external surface of the cabinet under specified ambient conditions.

The test method, test conditions, and the compliance are given in Annex D of Part 2 of this standard.

## 14 ICE-MAKING TEST (IF APPLICABLE)

The purpose of this test is to check the claim, if any, for the ice making capability of the appliance.

NOTE — This test does not apply to automatic ice makers.

### 14.1 Procedure

#### 14.1.1 Ambient Temperature

The ambient temperature shall be + 43 °C and shall be controlled within the tolerances specified in [Annex B](#).

#### 14.1.2 Preparation of the Appliance

The appliance shall be installed in the test room in accordance with [Annex B](#) and set up as in service in accordance with the manufacturer's instructions. The means of access (doors or lids) shall be kept closed during the test.

The temperature sensing controls (thermostat) shall be set in accordance with the manufacturer's instructions. When no instructions are given, the thermostat position shall be the same as that for the storage test specified in Part 2 of this standard.

The cellar compartment, if any, shall be as small as possible (if the volume is adjustable), with temperature control devices (flaps, etc) set in the position in accordance with the manufacturer's instructions or the same as that for the storage test.

#### 14.1.3 Measurements

After stable operating conditions have been attained, the ice tray(s) shall be filled with water up to 5 mm from the top and placed in the appliance at the position recommended by the manufacturer at the commencement of a defrosting cycle.

If a sub-division is provided specifically for making and storing ice and is not removable without the use of tools, the ice trays shall be placed in that sub-division. The water temperature at the moment of placing the ice tray(s) in the appliance shall be + 30 °C ± 1 °C.

The ice tray(s) shall be examined for complete freezing of the water after an interval equal to the ice making time stated by the manufacturer has elapsed or as estimated from the stated ice making capabilities of the appliance.

### 14.2 Test Report

The test report shall contain the following information:

- a) Quantity, in kilograms, of ice produced in a 24 h period or the time, expressed in hour and minute, necessary to freeze the water in the ice tray(s) supplied with the appliance; and
- b) Whether the requirements in accordance with Part 3 of this standard are met with regard to ice making tests.

## 15 TEST FOR ABSENCE OF ODOUR AND TASTE

The purpose of this test is to check that materials used for the internal components of the fresh food storage compartments and cellar and chill compartments, if any, will not impart either taste or odour to food.

### 15.1 Procedure

#### 15.1.1 Ambient Temperature

The ambient temperature shall be between + 16 °C and + 32 °C.

#### 15.1.2 Cleaning

The appliance shall be cleaned prior to the test in accordance with the manufacturer's instructions and afterwards with pure water.

#### 15.1.3 Temperature Sensing Controls Setting

The appliance shall first be operated for 48 h, with the temperature sensing controls (thermostat) and other control devices set in a position which will give the following temperatures:

- a) Fresh food storage compartment:

$$t_{am} = + 4 \text{ °C} \pm 2 \text{ °C};$$

- b) Cellar compartment:

$$+ 8 \text{ °C} \leq t_{em.a} \leq + 14 \text{ °C}; \text{ and}$$

- c) Chill compartment:

$$- 3 \text{ °C} \leq t_{ec} \leq + 3 \text{ °C}.$$

#### 15.1.4 Samples

The analytical samples and check samples respectively for each compartment shall be:

- a) 100 ml potable water; and
- b) A slice of fresh unsalted butter of dimensions 75 mm × 35 mm × 5 mm.

From each of (a) and (b), at least six samples are necessary to serve as analytical samples and at least six to serve as check samples.

The analytical samples shall be placed in petri dishes and the check samples in glass containers, the latter being hermetically sealed. Prior to the test, all petri dishes and containers which are used for the test shall be cleaned with timing nitric acid and subsequently washed with distilled water until the complete absence of odour is obtained.

The analytical samples of water and butter shall be placed uncovered in the fresh food storage, cellar, and chill compartments.

The check samples in the hermetically sealed glass containers shall be placed close to the analytical samples.

**15.1.5 Test Period**

The analytical samples and the check samples shall be left in the operating appliance with the door(s) closed and at the specified temperature conditions for 48 h.

After 48 h, the analytical samples shall be covered. Then the analytical samples and check samples shall be removed and warmed up to approximately 20 °C by leaving them in the test room.

**15.2 Examination of Samples****15.2.1 Conditions**

Examination shall be made about 2 h after removal of the samples from the appliance and shall be carried out by at least three expert assessors familiar with the test method. Each expert assessor shall receive:

- a) Two analytical samples of water;
- b) Two check samples of water;
- c) Two analytical samples of butter; and
- d) Two check samples of butter.

The identity of the samples shall not be made known to the expert assessors. Examination for odour shall be carried out before examination for taste.

The samples of water shall be examined prior to the samples of butter unless a separate examination by different expert assessors takes place.

The examiners shall record their remarks, independently of each other, in writing.

**15.2.2 Evaluation**

The evaluation of the analytical samples shall be carried out with reference to the following scale:

- a) Mark 0: No foreign odour or foreign taste;
- b) Mark 1: Slight foreign odour or foreign taste;
- c) Mark 2: Definitely perceptible foreign odour or foreign taste; and
- d) Mark 3: Distinct foreign odour or foreign taste.

If the requirement in accordance with [8.2](#) is not clearly met, the test shall be repeated. The following provisions shall be made for the second test:

- a) Cleaning of the compartments;
- b) Operation of the empty appliance for one week; and
- c) Temperature adjustment in the fresh food storage, cellar, and chill compartment for the second test for absence of odour and taste.

**16 SAFETY REQUIREMENTS**

The refrigerator shall comply with the safety requirement given as per the following of IS 302-1:

- a) Protection against access to live parts (*see 8*);
- b) Power input and current (*see 10*);
- c) Heating (*see 11*);
- d) Leakage current and electric strength at operating temperature (*see 13*);
- e) Moisture resistance (*see 15*); and
- f) Leakage current and electric strength (high voltage after humidity) (*see 16*).

**17 PACKING**

The refrigerator shall be packed in such packages, which are made of recyclable or biodegradable materials. At least 80 percent by weight of the packaging material to be recyclable or biodegradable and identified by proper symbol.

**18 DESIGNATION**

The refrigerator shall be designated according to:

- a) Type (for example, single door or double door, frost-free refrigerator, food freezer, etc);
- b) Operating principle (compression);
- c) Class (tropical *T*);
- d) Rated total volume, either in cubic decimetre or in litre;
- e) Rated total storage volume, either in cubic decimetre or in litre, together with the rated;
- f) Rated total volume of the food freezer compartment, and the star classifications(s);
- g) Rated total volume(s) of any frozen food, storage compartment(s), and any 'two-star' section(s), if applicable; and
- h) Pull down time, in min.

**19 INSTRUCTIONS FOR USE AND MAINTENANCE**

Every appliance shall be accompanied on delivery by the manufacturers' instruction manual for its use and maintenance. The instructions shall include, in particular, the following information.

- a) Installation requirements (best location, levelling, connection - if required for defrost water, connections to energy source);
- b) Overall space required in use (*see 3.4.5*), with sketches showing the appliance with the means of access open and closed;

- c) For appliances which are intended to be built in, the recess dimensions together with any additional ventilation requirements;
- d) Operating conditions (starting and stopping procedures);
- e) Instructions for use of the various controls [such as temperature sensing controls (thermostat) (s), fast freeze switch, indicator lights, air circulation, and defrosting control(s)];
- f) Limit values of the range of ambient temperature for the climate class for which the appliance is designed and the fact that the internal temperatures may be affected by such factors as the location of the appliance, ambient temperature and the frequency of door opening. If appropriate, a warning shall be given that the setting of the thermostat or other temperature control devices might have to be varied to allow for these factors;
- g) Care required for best performance, such as:
  - 1) Loading the appliance [especially when the storage volume of the food freezer compartment (or cabinet) or any 'three-star' compartment(s) (or cabinet) is smaller than the corresponding gross volume and when no load limit lines exist];
  - 2) The use of baskets and where appropriate, a warning on the risk of poor performance when the baskets are not used;
  - 3) The arrangement of food for storage, in particular the need to avoid cross contamination;
  - 4) The arrangement of food for storage and for freezing, where applicable, including, in particular, advice that food to be frozen shall not be placed in direct contact with food in storage and if appropriate, that it may be necessary to reduce the quantity to be frozen if freezing every day is anticipated; and
  - 5) In the case of appliances with chill compartments, it should be stated that some types of fresh vegetables and fruit are sensitive to cold; therefore, they are not suitable for storage in this kind of compartment.
- h) Maintenance and cleaning of the appliance;
- j) Fact that effervescent drinks should not be stored in food freezer compartments (or cabinets) or in low-temperature compartments (or cabinets), and that some products such as water ices should not be consumed too cold;
- k) Need to not exceed the storage time(s) recommended by the food manufacturers for commercially quick-frozen food in food freezer and frozen food storage compartments (or cabinets);
- m) Care required with regard to frozen food in storage in the event of an extended non-running of the appliance (interruption of power supply or failure of the refrigerating system);
- n) Action to be taken when the appliance is switched off and taken out of service temporarily or for an extended period, for example, emptied, cleaned and dried, and the door(s) or lid(s) propped a jar; and
- p) Necessity that, for doors or lids fitted with locks and keys, the keys should be kept out of the reach of children and not in the vicinity of the appliance, in order to prevent children from being locked inside.

Manufacturers are free to provide any additional instructions if required.

## 20 SCHEDULE OF TESTS

### 20.1 Type Tests

The tests specified in [Table 2](#) shall constitute the type tests and shall be carried out on a sample selected preferably at random from regular production or from the finished stock. Before commencement of the tests, the refrigerator shall be visually examined and inspected of components, parts and their assembly, constructions, mechanical hazards, marking provision of suitable terminals for supply connections, earthing and the effectiveness of screws and connection. The external surface finish shall be even and free from finishing defects.

**20.2** The acceptance tests shall be as provided in the [Table 3](#).

### 20.3 Production Routine Test

Each refrigerator shall be subjected to the routine tests at the manufacturer's works which shall be carried out without loading the refrigerator. The following shall constitute as routine test as per IS 302-1:

- a) Leakage current test — The leakage current shall not exceed 3.5 mA at rated voltage (*see 13.2*);
- b) Earth continuity test (*see B-1*); and
- c) Electric strength (*see B-2*).

**Table 2 Type Tests**(Clause [20.1](#))

SI No. (1)	Tests (2)	Clause Reference (3)
i)	Marking	<a href="#">5</a>
ii)	Design and construction	<a href="#">8</a>
iii)	Air tightness of doors or lid seals	<a href="#">9</a>
iv)	Force of opening of doors and lids	<a href="#">10</a>
v)	Durability of hinges and handles of doors and lids	<a href="#">11</a>
vi)	Mechanical strength of shelves and similar components	<a href="#">12</a>
vii)	Ice making test	<a href="#">14</a>
viii)	Test for absence of odour and taste	<a href="#">15</a>
ix)	Safety requirements	<a href="#">16</a>
x)	Storage test	6 of Part 2 of this standard
xi)	Cooling capacity test	7 of Part 2 of this standard
xii)	Freezing capacity test	8 of Part 2 of this standard
xiii)	Automatic ice making capacity test	9 of Part 2 of this standard
xiv)	Pull down test	4.6 a) of Part 2 of this standard
xv)	Wine storage test	4.6 b) of Part 2 of this standard
xvi)	Temperature rise test	4.6 c) of Part 2 of this standard
xvii)	Water vapour condensation test	13 and 4.6 d) of Part 2 of this standard
xviii)	Measurement of volume	4.8 and Annex H of Part 3 of this standard
xix)	Determination of energy consumption	6 of Part 3 of this standard

**Table 3 Acceptance Tests**(Clause [20.2](#))

SI No. (1)	Tests (2)	Clause Reference (3)
i)	Marking	<a href="#">5</a>
ii)	Air tightness of doors or lid seals (door seal test)	<a href="#">9</a>
iii)	Force of opening of doors and lids	<a href="#">10</a>
iv)	Durability of hinges and handles of doors and lids	<a href="#">11</a>
v)	Mechanical strength of shelves and similar components	<a href="#">12</a>
vi)	Water vapour condensation test	<a href="#">13</a>
vii)	Ice making test	<a href="#">14</a>
viii)	Test for absence of odour and taste	<a href="#">15</a>
ix)	Storage test	6 of Part 2 of this standard

Table 3 (Concluded)

SI No. (1)	Tests (2)	Clause Reference (3)
x)	Cooling capacity test	7 of Part 2 of this standard
xi)	Freezing capacity test	8 of Part 2 of this standard
xii)	Automatic ice making capacity test	9 of Part 2 of this standard
xiii)	Pull down test	4.6 a) of Part 2 of this standard
xiv)	Temperature rise test	4.6 c) of Part 2 of this standard
xv)	Measurement of volume	4.8 of Part 3 of this standard
xvi)	Determination of energy consumption	6 of Part 3 of this standard
xvii)	Door seal test	<a href="#">9</a>
xviii)	Thermostat function test	<a href="#">8.11</a>
xix)	Protection against electric shock	8 of IS 302-1
xx)	Input and current	10 of IS 302-1
xxi)	Temperature rise	11 of IS 302-1
xxii)	Electrical insulation and leakage current at operating temperature	13 of IS 302-1
xxiii)	Moisture resistance	15 of IS 302-1
xxiv)	Insulation resistance and electric strength (after humidity treatment)	16 of IS 302-1



## ANNEX A

(Clause 2)

## LIST OF REFERRED STANDARDS

<i>IS No./Other Standards</i>	<i>Title</i>	<i>IS No./Other Standards</i>	<i>Title</i>
IS 2 : 2022	Rules for rounding off numerical values ( <i>second revision</i> )	IS/ISO/IEC 17025 : 2017	General requirements for the competence of testing and calibration laboratories ( <i>second revision</i> )
IS 302 (Part 1) : 2008	Safety of household and similar electrical appliances: Part 1 General requirements ( <i>sixth revision</i> )	IS 17550 (Part 2) : 2021	Household refrigerating appliances — Characteristics and test methods: Part 2 Performance requirements
IS 694 : 2010	Polyvinyl chloride insulated unsheathed and sheathed cables/cords with rigid and flexible conductor for rated voltages up to and including 450/750 V ( <i>fourth revision</i> )	IS 17550 (Part 3) : 2021	Household refrigerating appliances — Characteristics and test methods: Part 3 Energy consumption and volume
IS 1060 (Part 1) : 2022	Methods of sampling and test for paper and allied products: Part 1 Test methods for general purpose ( <i>second revision</i> )	IS/IEC 60730-2-9 : 2011	Automatic electrical controls for household and similar use: Part 2 Particular requirements, Section 9 Temperature sensing controls
IS 10617 : 2018	Hermetic compressors — Specification ( <i>second revision</i> )	IEC 62552-1 : 2015	Household refrigerating appliances — Characteristics and test methods: Part 1 General requirements
IS 16656 : 2017/ ISO 817 : 2017	Refrigerants — Designation and safety classification		

To access Indian Standards click on the link below:

[https://www.services.bis.gov.in/php/BIS\\_2.0/bisconnect/knowyourstandards/Indian\\_standards/isdetails/](https://www.services.bis.gov.in/php/BIS_2.0/bisconnect/knowyourstandards/Indian_standards/isdetails/)

## ANNEX B

(Clauses [3.5.8](#), [14.1.1](#), [14.1.2](#), [C-2.3.1](#), and [G-7.1](#))

## TEST ROOM AND INSTRUMENTATION

**B-1 SCOPE**

This Annex specifies instrumentation accuracies and test room characteristics required to carry out measurements and tests for the determination of the performance and energy consumption of refrigerating appliances in accordance with the procedures in Part 2 and Part 3 of this standard.

**B-2 INSTRUMENTS, ACCURACY, AND PRECISION OF MEASUREMENTS****B-2.1 General**

Laboratories shall have procedures in place to ensure that all measurement instruments are operating correctly and are regularly calibrated in accordance with good laboratory practice laid down in IS/ISO/IEC 17025. Rounding off shall not be done other than as and where specified in the relevant parts of this standard as per IS 2.

**B-2.2 Electrical Energy Consumption**

Measurements of energy consumption shall be made with an expanded uncertainty ( $k = 2$ ) of less than 2 percent or 8 Wh whichever is the larger value. Daily energy consumption shall be recorded to the nearest 1 Wh or better. Energy shall be recorded at least each minute or at each control event. Recording of instantaneous power and power factor in addition to energy is recommended.

NOTE — For a normal distribution this coverage factor  $k$  corresponds to a 95 percent confidence level.

**B-2.3 Humidity**

The humidity of the test room shall be measured and recorded at a point which is representative. Where a humidity range is specified the accuracy of the measuring instruments shall be such that the result, expressed as percent relative humidity, shall have an overall uncertainty of measurement of not greater than 5 percent. Where a one-sided humidity limit is specified, the accuracy of the equipment shall be sufficient to establish that the permitted limit has been met.

**B-2.4 Length**

Measurements of length shall have an expanded uncertainty ( $k = 2$ ) less than 1 m or 0.5 percent whichever

is greater. All lengths shall be recorded to the nearest 1 mm.

**B-2.5 Mass**

The measured mass shall have an expanded uncertainty ( $k = 2$ ) less than 5 g.

**B-2.6 Temperature**

Temperature data shall be recorded at equal measuring intervals not greater than 1 min.

Unless otherwise specified, the expanded uncertainty of measurement ( $k = 2$ ) shall not be greater than 0.5 K. All temperature measurements shall be recorded to the nearest 0.1 K or better.

Temperature transducers shall be inserted either into M-packages (*see* [Annex D](#)) or into the centre of solid masses made of brass or tin-covered copper having masses of  $25 \text{ g} \pm 5$  percent and a maximum dimension of 18 mm. Reference to a temperature sensor in this standard means the metal mass.

The masses should be kept clean to keep the emissivity coefficient low.

Connections from the temperature sensors shall be arranged to minimize additional air leakage into the compartments.

**B-2.7 Time**

Calculated values of test duration, made up of the difference between time recorded at each sampling period, shall have an expanded uncertainty ( $k = 2$ ) not more than 10 s or 0.1 percent, whichever is the greater. The time recorded for each sampling point shall have a resolution of 1 s or better. It is not a requirement of this standard to identify events that occur during (within) each sampling interval. However, use of an event recorder to identify the time of events within a sampling interval may improve data quality, especially where the product has relatively short control cycles.

**B-2.8 Voltage and Frequency**

The measured voltage and frequency shall have an expanded uncertainty ( $k = 2$ ) smaller than 0.5 percent. Energy data shall be recorded at equal measuring intervals not greater than 1 min.

### B-3 GENERAL TEST CONDITIONS

#### B-3.1 General

A number of parameters shall be kept constant as well as be kept close to a target value during the test, for example, ambient temperature or supply voltage as required in [B-3.2.2](#) and [B-3.3](#). Verification of these parameters involves the following (see [Fig. 8](#)):

- a) The average value over the time period of interest shall be determined and shall be within a first given tolerance of the target value:  $\text{Target} - \text{Tol 1} < \text{Average} < \text{Target} + \text{Tol 1}$ ; and
- b) The standard deviation over the time period of interest shall be determined and shall be smaller than a second given tolerance:  $2\sigma < \text{Tol 2}$ .

#### B-3.2 Ambient Temperatures

##### B-3.2.1 Sensors

Ambient temperatures are measured using copper

or brass masses (see [B-2.6](#) and [B-4.5](#)).

##### B-3.2.2 Temperature Stability

During any period to obtain product stabilisation and during the subsequent test period, the following shall be valid for each of the recorded ambient temperatures sensors  $T_{a1}$  and  $T_{a2}$ :

- a) The time averaged value shall be within  $\pm 0.5$  K of the test ambient temperatures specified in [B-3.2.3](#); and
- b) Two times the standard deviation shall be smaller than 0.5 K.

The vertical ambient temperature gradient as specified in [B-4.5](#) shall not exceed 1 K/m.

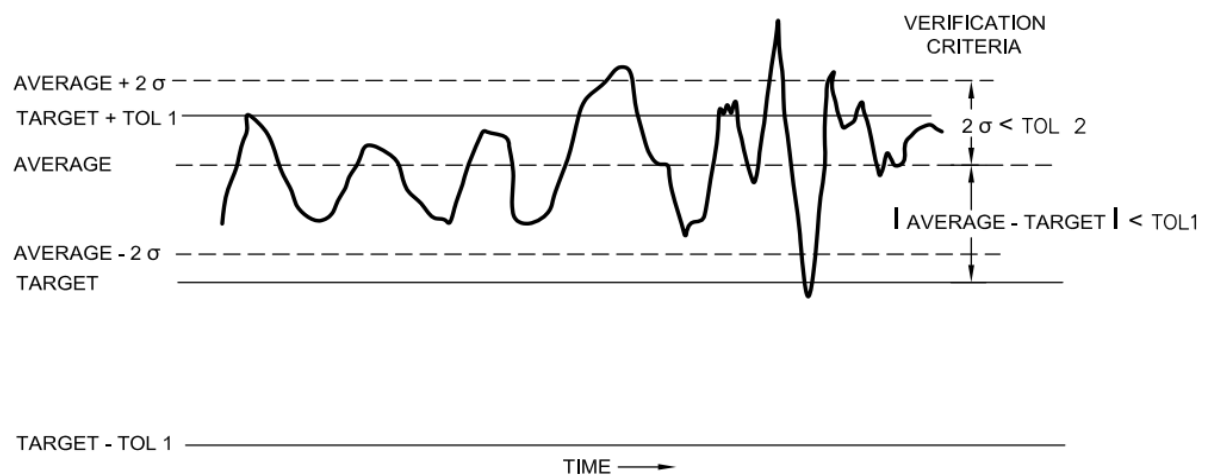

#### Key

$\sigma$  — Standard deviation

Tol 1 — Tolerance from the target value

Tol 2 — Parameter fluctuations are constrained by requiring that 2 times the standard deviation is smaller than a given tolerance (Tol 2) which means that 95 percent of the measurement data points have to be within this tolerance (assuming a normal distribution of the parameter of interest). This is independent of sampling frequency.

FIG. 8 VERIFICATION OF PARAMETERS TO BE KEPT CONSTANT

### B-3.2.3 Temperature Values

Tests shall be carried out under the following ambient temperature conditions:

- a) For assessing the storage temperatures:  
+ 16 °C and + 43 °C for class T refrigerating appliances.

For products rated for multiple climate classes, tests need to be performed at the extreme ambient temperatures only of all the relevant rated classes. Testing details are specified in 6 of Part 2 of this standard. In addition, verification tests may be carried out at any ambient temperature between the minimum and maximum temperature defined by the climate class in order to confirm compliance with the storage temperature requirements at any ambient temperature.

*Example:*

For refrigerating appliances rated T, tests are performed at + 16 °C and at + 43 °C.

- a) For determination of energy consumption as specified in 6 of Part 3 of this standard:  
+ 32 °C for all refrigerating appliances.

NOTE — This test at + 16 °C is under consideration.

- b) For assessing the temperature rise time, freezing capacity, cooling capacity, and automatic ice making capacity of all refrigerating appliances, as applicable and specified in 7 to 9 and Annex C of Part 2 of this standard:

+ 25 °C for all classifications of refrigerating appliances.

- c) For assessing the pull-down performance test as specified in Annex A of Part 2 of this standard: at the maximum ambient temperature in accordance with the climate class specified; and

- d) For assessing the water vapour condensation test as specified in Annex D of Part 2 of this standard:

+ 32 °C for class T refrigerating appliances.

NOTE — In India climate class T has been considered.

### B-3.3 Electricity Supply

The test voltage and the test frequency shall be:

- a) The rated voltage not exceeding 250 V and rated frequency of 50 Hz; and

- b) Where a voltage and frequency range are specified, the refrigerating appliance shall be tested at the mean of the rated voltage range and the highest rated frequency.

For check testing purposes the total harmonic distortion in the voltage supply shall be not more than 3 percent and its value shall be included in the test report. The source of the electricity supply shall be described in the test report.

During each test the following shall be valid for the recorded voltage sampled at each sampling period at the point of connection:

- a) The time averaged value shall be the test voltage  $\pm$  1 percent; and
- b) Two times the standard deviation shall be smaller than 1 percent of the time averaged value.

During each test the following shall be valid for the recorded instantaneous supply frequencies at the point of connection:

- a) The time averaged value shall be the test frequency  $\pm$  1 percent; and
- b) Two times the standard deviation shall be smaller than 1 percent of the time averaged value.

### B-3.4 Power Supply Other than Electricity

Refrigerating appliances other than those for electric power supply shall be tested under supply conditions corresponding to the information marked on the appliance.

### B-3.5 Multiple Power Supply

Refrigerating appliances that are equipped for operation on energy sources other than or in addition to mains power should be tested at each of the supply conditions indicated on the appliance.

### B-3.6 Humidity

Unless otherwise specified for specific performance or energy tests, the relative humidity shall not exceed 75 percent. For tests at 10 °C ambient temperature this relative humidity limit does not apply. For energy tests at an ambient temperature of 16 °C, the test result is invalid if the measured ambient relative humidity exceeds 75 percent during the test and condensation is visible as droplets or running water (as interpreted in accordance with Annex D of Part 2 of this standard).

## B-4 TEST ROOM CONFIGURATION

### B-4.1 General

The appliance shall be installed in a test room setup as follows:

### B-4.2 Platform

Each refrigerating appliance shall be placed on a wood or wood product, for example, plywood or reconstituted wood sheeting solid-top platform painted dull black and open for free air circulation under the platform. A suspended floor meeting the other specifications of a platform is considered to be a platform. As an alternative to black paint, a wooden platform or floor may be covered with a low emissivity dark coloured, non-glossy, smooth, impermeable surface, such as linoleum.

The bottom of the platform shall not be less than 0.05 m above the test room floor and shall extend at least 0.3 m beyond all sides of the refrigerating appliance under test, except at the rear where the platform shall extend to the rear wall or partition.

A raised platform is not required where the test room floor is made of wood or wood product, where there is insulation below the floor and the surface temperature of the floor remains within 1.5 K times of the lower test room temperature gradient sensor. The floor surface temperature shall be recorded at a representative position throughout the test to check the validity of this requirement.

### B-4.3 Rear Wall or Partition

The surface behind the appliance shall be rigid, vertical and made of wood, or wood product and painted dull black. This surface shall be continuous, extend not less than 0.3 m to each side of, and above the appliance. The surface may be fixed to the wall of the test room with a gap of at least 0.03 m or be in the form of a fixed partition within the test room.

### B-4.4 Side Partitions

Where the unit under test has a fan forced condenser, shielding shall be included, where applicable to ensure that hot condenser exhaust does not directly affect any adjacent product under test. Side partitions are not required for testing units with a front exhaust.

Where a product has any type of hot wall condenser at the back and/or side, a continuous wood or wood product partition painted dull black, parallel to each side of the appliance and fixed on the platform at least 0.3 m from the sides of the appliance shall be used. The partitions shall extend at least 0.3 m above

the appliance and shall be at least 0.3 m deep. Where necessary, for example, where there are side-wall condensers, the side partitions shall be extended so they are deep enough to shield any adjacent appliance under test from direct radiation from the condenser.

Some products may have both wall condensers and fan forced condensers, so both of the above rules need to be applied in this case. Products with fan forced condensers may have side partitions fitted for testing if the test laboratory chooses to do so.

### B-4.5 Sensor Location

The ambient temperature sensors shall be located at two positions,  $TMPa_1$  and  $TMPa_2$  on each side of the appliance under test. The height of the temperature sensors above the platform shall be  $0.9 \text{ m} \pm 0.1 \text{ m}$  or the height of the appliance under test  $\pm 0.1 \text{ m}$ , whichever is lower. The depth of the temperature sensors from the rear partition shall be  $0.3 \text{ m} \pm 0.1 \text{ m}$ . The side clearance of the temperature sensors shall be  $0.3 \text{ m} \pm 0.1 \text{ m}$  from the refrigerating appliance. In the case where a side partition extends forward of the ambient temperature sensor position or where an external wall forms the side partition, the relevant ambient temperature sensor shall be located on the appliance side of the partition and, where necessary, shielded from any radiation from the appliance. The clearance of the ambient temperature sensor to any partition or fixture shall be at least 25 mm.

To assess the temperature gradient, two additional sensors in the test room shall be located at a height of 0.05 m above the platform and at a height of 2 m above the platform (not shown in [Fig. 9](#)) in a position that is representative of ambient conditions in the test room.

Ambient temperature sensors shall be shielded from any sources or sinks of radiant heat which differ from the measured air temperature in the test room by more than 5 K, including conditioning equipment, external windows, or appliances under test.

### B-4.6 Test Room General Configuration

The refrigerating appliance shall be placed or shielded from any sources or sinks of radiant heat which differ from the measured air temperature in the test room by more than 5 K. Sources or sinks of radiant heat could include conditioning equipment, external windows or other appliances under test.

Air circulation in the test room shall be such that the specified ambient temperatures are obtained within the limits of the specified tolerances. The

refrigerating appliance under test shall be shielded from any air currents with a velocity above 0.25 m/s. During test room operation, after installation of the appliance but without it necessarily running, a check of the air velocity measurement at the centre of all accessible appliance walls, including the top at 0.3 m distance would satisfy this requirement.

The air circulation in the test room shall not interfere with the normal air circulation created by the refrigerating appliance.

The test room configuration for a single appliance is illustrated in [Fig. 9](#).

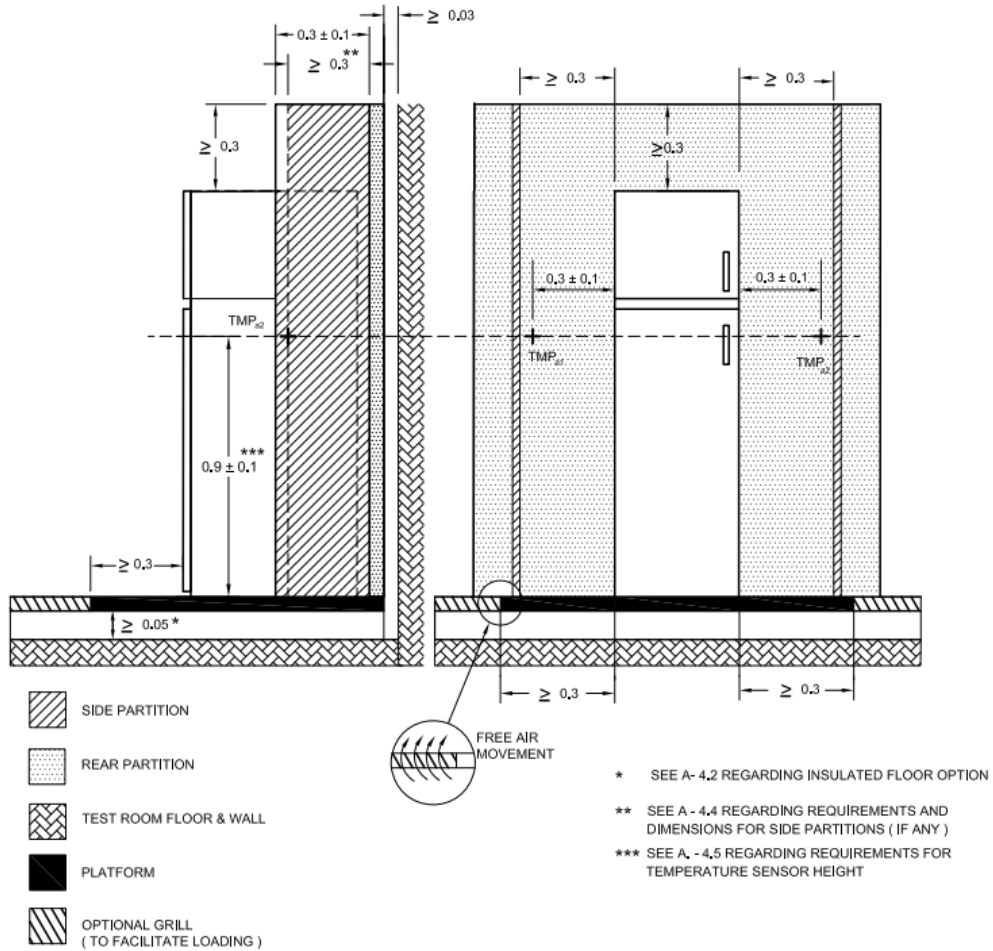

All dimensions in metres.

FIG. 9 PARTITIONS TO RESTRICT AIR CIRCULATION AND AMBIENT TEMPERATURES SENSOR POSITIONS



## ANNEX C

(Clauses [G-7.1](#) and [G-9.2](#))**PREPARATION OF AN APPLIANCE FOR TESTING AND GENERAL MEASUREMENT PROCEDURES****C-1 SCOPE**

This Annex specifies requirements for preparing an appliance for testing and test conditions to be complied with when determining its performance and energy consumption in accordance with Part 2 and Part 3 of this standard, as applicable.

**C-2 PREPARATION AND SET-UP OF APPLIANCE****C-2.1 General**

The following requirements for preparation of an appliance for measurement or testing shall be met, except where specifically varied in Part 2 or Part 3 of this standard.

**C-2.2 Running in of New Appliances**

For verification testing, prior to commencement of its first average power consumption measurement, the appliance shall have been run in for at least 12 h compressor run time. Non-compressor based appliances shall be operated for at least 12 h prior to energy consumption measurements. The 'run-in' may be made at any convenient room temperature or it may be part of any temperature stabilisation section of an average power consumption measurement.

**C-2.3 Installation of the Appliance in the Test Room**

**C-2.3.1** The appliance shall be installed in a test room with measuring instruments as specified in [Annex B](#).

**C-2.3.2 Rear Clearance**

For the determination of rear clearance, the following dimensions are defined as illustrated in [Fig 10](#):

- a) *Dimension A* — The distance from the rearmost projection of the appliance (including any spacer fitted) to the test room wall (or simulated wall behind the appliance); and
- b) *Dimension B* — The distance from the rear plane of the appliance to the test room wall (or simulated wall behind the appliance). The measurement shall be taken at the

lowest point of the rear plane whether or not the rear plane is vertical.

The rear plane of the appliance is the largest flat surface at the rear of the cabinet shell excluding any local features, namely stack condensers or protrusions associated with brackets or the compressor.

The appliance shall be assembled and located in the test room in accordance with the following rules:

- a) The appliance shall be assembled in accordance with the instructions (including any spacers that are to be fitted, assembled, or activated at the time of installation);
- b) In plan view, the rear of the appliance shall be positioned parallel to the test room wall or simulated wall behind it;
- c) If rear clearance is not specified, the appliance shall be located with the rearmost projection against the test wall (Dimension A = 0 mm); and
- d) If clearance is specified, the appliance shall be placed in the test bay in accordance with the rear clearance instructions except where the distance from the rear plane of the appliance to the test wall (Dimension B) specified is > 51 mm. In this case the distance shall be adjusted such that either Dimension A = 0 mm or Dimension B = 51 mm.

If spacers that are to be fitted, assembled, or activated at the time of installation result in the distance from the rear plane of the appliance to the test wall (Dimension B) being equal to or more than 80 mm, then the spacers shall not be used. Where fitting rear spacers conflicts with any relevant dimensions in the manufacturer's literature, the smallest clearance specified shall be used. Where spacers are fitted, they shall be treated in accordance with the above rules.

Where no clearance is specified for appliances that require space behind for the lid operation, etc. such as a chest freezer, the rearmost position of the lid during opening to a vertical position shall be considered the rearmost projection of the appliance.

For portable refrigerating appliances and freestanding absorption-type appliances in which

refrigeration is affected by an absorption process using heat as an energy source, the manufacturer's specification for the rear clearance shall be followed. If no spacers are defined, the distance between the rearmost projection and the wall shall be 20 mm or less.

**C-2.3.3 Built-in Appliances**

Appliances intended to be built-in shall be built-in in accordance with the instructions provided and in accordance with the requirements set out below.

Rear clearances shall be as set out in [C-2.3.2](#).

Refrigerating appliances intended only to be built-in or placed under a counter or under a worktop, or between cabinets (under-counter types), shall be built-in or placed in a test enclosure painted dull black. The enclosure shall be made of wood or wood product (for example, plywood, or reconstituted wood sheeting) in the range 15 mm to 25 mm thick. If a manufacturer requires a fascia door, it shall be fitted.

The inner dimensions of the test enclosure shall comply with the instructions. If a range of dimensions are given, then the smallest values shall be used. If this data is not given, the inner dimensions of the test enclosure shall be as follows:

- a) The inner depth shall exceed by 20 mm to

22 mm the overall depth of the refrigerating appliance;

- b) The inner width shall exceed by 4 mm to 6 mm the overall width of the refrigerating appliance; and
- c) The inner height shall exceed by 2 mm to 4 mm the overall height of the refrigerating appliance.

If necessary, the test enclosure shall be provided with ventilating openings according to the instructions.

The refrigerating appliance shall be built-in or placed in the test enclosure according to the instructions.

If the refrigerating appliance is provided with spacers, strips, or other special means of solid or resilient material for closing the gap between the contours of the refrigerating appliance and the cabinet or enclosure, these means shall be used accordingly. If such means are not provided, the gaps between the test enclosure and the refrigerating appliance shall be left open.

To prevent airflow, the junction between the sides and back of the test enclosure shall be in close contact and sealed if necessary.

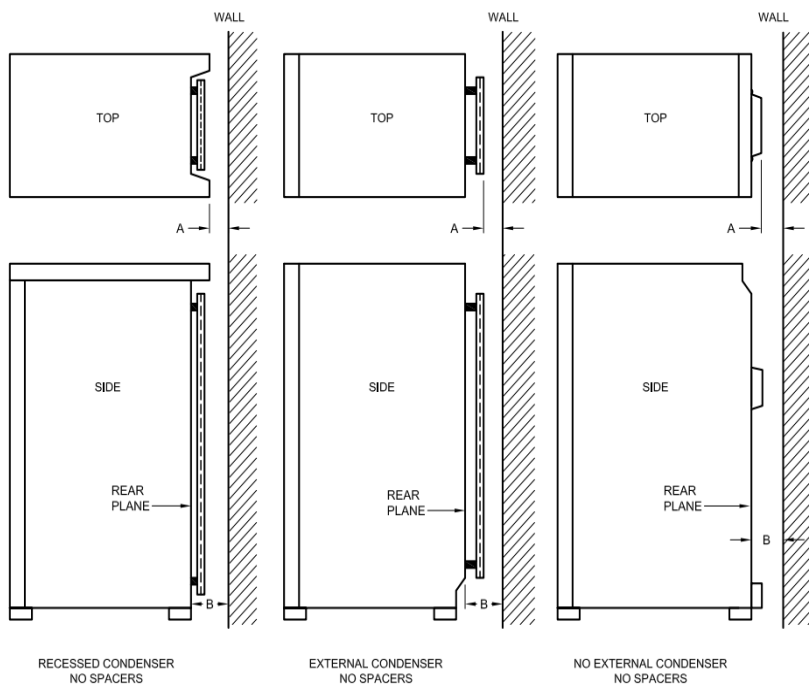

FIG. 10 EXAMPLES OF APPLIANCES WITH NO SPACERS WHERE REAR CLEARANCE IS SPECIFIED

**C-2.3.3 Built-in Appliances**

Appliances intended to be built-in shall be built-in in accordance with the instructions provided and in accordance with the requirements set out below.

Rear clearances shall be as set out in [C-2.3.2](#).

Refrigerating appliances intended only to be built-in or placed under a counter or under a worktop, or between cabinets (under-counter types), shall be built-in or placed in a test enclosure painted dull black. The enclosure shall be made of wood or wood product (for example, plywood, or reconstituted wood sheeting) in the range 15 mm to 25 mm thick. If a manufacturer requires a fascia door, it shall be fitted.

The inner dimensions of the test enclosure shall comply with the instructions. If a range of dimensions are given, then the smallest values shall be used. If this data is not given, the inner dimensions of the test enclosure shall be as follows:

- a) The inner depth shall exceed by 20 mm to 22 mm the overall depth of the refrigerating appliance;
- b) The inner width shall exceed by 4 mm to 6 mm the overall width of the refrigerating appliance; and
- c) The inner height shall exceed by 2 mm to 4 mm the overall height of the refrigerating appliance.

If necessary, the test enclosure shall be provided with ventilating openings according to the instructions.

The refrigerating appliance shall be built-in or placed in the test enclosure according to the instructions.

If the refrigerating appliance is provided with spacers, strips, or other special means of solid or resilient material for closing the gap between the contours of the refrigerating appliance and the cabinet or enclosure, these means shall be used accordingly. If such means are not provided, the gaps between the test enclosure and the refrigerating appliance shall be left open.

To prevent airflow, the junction between the sides and back of the test enclosure shall be in close contact and sealed if necessary.

**C-2.4 Combined Appliances**

An appliance combined with an appliance other than a refrigerating appliance shall be subjected to the tests and measurement while they are combined, but with the other appliance operating at the lowest

possible user selectable energy consuming conditions, including 'off' or not functioning.

**C-2.5 Setting Up****C-2.5.1 General**

The appliance shall be set up in accordance with the instructions, except where these conflict with the requirements of this standard. All packing materials such as skid boards, base packers, pallets, etc are to be removed.

Except as follows, all internal fittings including drawers, bins, and containers supplied with the appliance shall be put in position. Any specific variations in any test procedure specified in Part 2 or Part 3 of this standard may override a), b), c), or d) of [C-2.5.1](#).

- a) In the case of a frozen compartment, any ice cube trays having no specific subdivision to accommodate such trays shall be removed. All other ice cube trays shall be placed in position;
- b) Where a shelf has a convenience feature that attaches to it, the shelf and convenience feature shall be located in a position that is anticipated to have the least impact on temperature sensor positioning and result;
- c) Any trays, bins, or containers that have no dedicated position(s) shall be removed; and
- d) For requirements for shelves in relationship to temperature sensor locations (*see* [Annex E](#)).

**C-2.5.2 Variable Temperature Compartments**

Where the compartment is a variable temperature compartment type (that spans the operating range of several compartment types), it shall be classified:

- a) For the storage test [IS 17550 (Part 2)] : Each variable temperature compartment shall be capable of maintaining specified internal temperatures for each claimed compartment type at ambient temperatures across the rated range;
- b) For the cooling capacity test [IS 17550 (Part 2)] : If the variable temperature compartment can be used as a fresh food compartment, it shall be operated as a fresh food compartment type where this test is performed;
- c) For the freezing capacity and temperature rise time tests [IS 17550 (Part 2)] : If the variable temperature compartment can be

## IS 17550 (Part 1) : 2024

used as a three-star or four-star compartment, it shall be operated as a three- star or four-star compartment type where this test is performed; and

- d) For the energy consumption, water vapour condensation and ice making capacity tests [IS 17550 (Part 2) and IS 17550 (Part 3)], as applicable: the variable temperature compartment shall operate as the compartment type, which has the highest energy consumption for the energy test.

Additional requirements regarding each compartment type are specified in Table 1 of IS 17550 (Part 3), during the energy consumption test. In the energy consumption test, where a refrigerating appliance has variable temperature compartments that can operate as more than one compartment type, additional compartment classifications may be tested, if required, in addition to the primary classification specified above.

### C-2.5.3 User-Adjustable Features

User-adjustable features shall be treated as follows:

- a) Where provision is made for the user of an appliance to alter the balance of the volume of one type of space in relation to another, except where otherwise specified, this balance shall be set so that the volume of the colder space is maximised;
- b) Where an appliance is fitted with user-operated selectors or switches for functions which change operating temperatures for a period of limited duration, examples, fast freeze devices, each shall, except where otherwise specified, be set so that these functions are inoperative;
- c) Where user-operated switches are provided for items such as displays, butter conditioner, network connections, or secondary functions, for example screens that are intended to operate on a continuous basis, each shall be set in accordance with instructions. Accessories not necessary for the normal operation of the refrigerating appliance and not intended to operate on a continuous basis shall remain non-operational during testing;
- d) Where user-operated controls are provided for anti-condensation heaters, they shall be set as specified for the specific test in IS 17550 (Part 2) and IS 17550 (Part 3);
- e) Where user-operated baffles or controls are provided for adjustment of temperatures in convenience features, and these have not been classified as sub-compartments, each

shall be set so that the energy consumption is maximized except where specified otherwise for operating temperature performance tests;

- f) Where user-adjustable directional air ducts, vents, or outlets are present, these shall be set as per instructions providing they are not directed within 30° of the centre line of any temperature sensor positions. If no specific instructions are provided, they shall be fully open and set to the mid or central position or as close as possible to it providing they are directed at least 30° away from any temperature sensor positions. Where there is no mid or central position, the flow shall be adjusted to the most upward direction or where this is not possible, towards the door. Where ducts have an option for spreading or narrowing the airflow stream, these shall be set on the most divergent setting. If options are provided in the instructions, the option closest to the above shall be selected;
- g) Unless otherwise directed in the instructions, any manually controlled air circulation fans shall be switched on for power measurements;
- h) When the refrigerating appliance is not fitted with a user-adjustable temperature control, the refrigerating appliance shall be tested in the condition as shipped; and
- j) Where the settings of available controls on an appliance are not fully specified above, appliance control settings should be selected so as to demonstrate concurrent conformance with test requirements in all compartments during each test.

### C-2.6 Automatic Ice Makers

For all tests the storage bin shall remain in place.

For all tests, whether or not there is ice in the storage bin, the ice delivery mechanism shall remain functional, that is all chutes and throats required for the delivery of ice shall be free of packing, covers, or other blockages that may be fitted for shipping or when the automatic icemaker is not in use.

### C-2.7 Pre-Test Condition

Unless specified otherwise in Part 2 or Part 3 of this standard, on commencement of testing, compartments shall be empty, free of surface frost, and free of moisture. Means of access such as doors, drawers and lids etc, shall be kept closed except as specified in IS 17550 (Part 2) and IS 17550 (Part 3).

## ANNEX D

(Clauses [B-2.6](#) and [G-7.1](#))

## TEST PACKAGES

## D-1 DIMENSIONS AND TOLERANCES

The test packages used in the tests shall be in the form of rectangular parallelepipeds. Their size, prior to freezing, shall be  $50 \text{ mm} \pm 2.0 \text{ mm} \times 100 \text{ mm} \pm 3.0 \text{ mm} \times 100 \text{ mm} \pm 3.0 \text{ mm}$ . Their mass, packaging included, shall be  $500 \text{ g} \pm 10 \text{ g}$ .

To assist handling, test packages may be bound with a single tape layer to provide stacks with bases of  $100 \text{ mm} \times 100 \text{ mm}$ . Where stacks greater than 200 mm high are required they may be made by strapping 1 kg packs having dimensions of  $200 \text{ mm} \times 100 \text{ mm} \times 50 \text{ mm}$  so that they have a  $100 \text{ mm} \times 100 \text{ mm}$  footprint.

NOTE — In IEC 62552-1, 1 kg packs were defined ( $200 \text{ mm} \times 100 \text{ mm} \times 50 \text{ mm}$ ) that can be reused under this document by combining 2 packages vertically to form stacks with a footprint of  $100 \text{ mm} \times 100 \text{ mm}$ .

Test packages shall be checked regularly and shall not present visible holes or cracks on the wrapper. When any package is found to exceed the above-mentioned tolerances, it shall be replaced by a new package.

## D-2 COMPOSITION

The packages shall consist of the following:

- a) A suitable filling material containing, per 1 000 g:
  - 1) 230 g of oxyethylmethylcellulose;
  - 2) 764.2 g of water;
  - 3) 5 g of sodium chloride; and
  - 4) 0.8 g of 6-chloro-m-cresol. The freezing point of this material is  $-1 \text{ }^\circ\text{C}$ .
- b) The following alternative composition of test packages with a freezing point near  $-5 \text{ }^\circ\text{C}$  may be used:
  - 1) 232 g of oxyethylmethylcellulose;

- 2) 725 g of water;
  - 3) 43 g of sodium chloride; and
  - 4) 0.6 g of 6-chloro-m-cresol.
- c) Where test packages are required, packages of type a) or b) can be used, except:
    - 1) For unfrozen compartments, only packages (b) shall be used, for example:
      - i) During the freezing capacity test;
      - ii) For a chill compartment during the storage temperature test; and
      - iii) For a fresh food compartment during the cooling capacity test.
    - 2) For the light load during the freezing capacity test, only packages (a) shall be used;
    - 3) For one-star compartments, only packages (a) shall be used; and
    - 4) For the temperature rise time test, only packages (a) shall be used.

## D-3 M-PACKAGES

Some of the 500 g packages ( $50 \text{ mm} \times 100 \text{ mm} \times 100 \text{ mm}$ ) shall be equipped for temperature measurement and shall be known as M-packages. These shall be fitted with thermocouples or other temperature-measuring transducers, which shall be inserted in the geometric centre of the packages in direct contact with the filling material. All precautions shall be taken to minimize extraneous conduction of heat. All M-packages located close to the compartment door's gasket shall be oriented such that the sensor enters the package from the side furthest away from the door's gasket. The composition and the limitations of their use shall be in accordance with [D-1](#) and [D-2](#).

## ANNEX E

(Clauses [3.5.4](#), [C-2.5.1](#), [G-7.1](#), and [G-9.6](#))

## DETERMINATION OF COMPARTMENT AVERAGE AIR TEMPERATURES

## E-1 SCOPE

This Annex describes the required locations of sensors for measuring air temperatures in all compartments. It also describes the method of calculating the average air temperature at a point and within a compartment for various test procedures. The intent of this standard is to select positions that are representative of the compartment temperature where foodstuff is likely to be stored.

## E-2 LOCATION OF SENSORS

## E-2.1 General

The position specified for a temperature sensor is the geometric centre of the sensor (metal mass), except where minimum clearances are specified, in which case, clearance is to the outer surface of the metal mass.

Temperature sensor positions are specified in the following paragraphs. Clearances or heights specified are determined from the surface of the compartment at the specified positions. The surface may be the compartment liner or the surface of a convenience feature or a sub-compartment. Any fixed feature shall be treated as a surface.

The full height of a compartment ( $h_1$ ) is defined as the height at the front of the compartment or sub-compartment in accordance with [E-2.4.2](#). When the liner at the door seal is curved, the inner radius shall be taken as reference (see [Fig. 16](#)). The full height is used to define the number of sensors and to classify compartments as small or low-height compartments.

The effective height of a compartment ( $h$ ), which is used to define the height of sensors in a compartment, is defined as the height along a vertical line through temperature measurement point  $TMP_3$  for unfrozen compartments ([E-2.2](#)) and  $TMP_{14}$  for frozen compartments ([E-2.3](#)). This vertical line is defined as the h-line. The measurement is taken from the point where the h-line reaches the bottom surface of the compartment to the point where the h-line reaches the top surface of the compartment. Partitions or shelves are ignored when calculating the effective height. Where the surface of the compartment has a step change (edge) exactly at the h-line, the surface that is furthest away from the door is used to determine measurements.

NOTE — Where the position of  $TMP_3$  or  $TMP_{14}$  is shifted to meet clearance requirements, the h-line passes through the new position.

For frozen compartments having a partial width convenience feature where the side gap to the liner is 100 mm or greater and where the h-line is limited by this

convenience feature, the convenience feature shall be considered not in place for the determination of the h-line.

NOTE — This case applies, for example, to ice makers placed inside a frozen compartment, which can be placed on the left or right top side. As  $TMP_{14}$  is defined on the right side, this would result in different sensor positions in height whether the icemaker is placed on the left or the right. Using mirrored positions, as mentioned in [E-2.4.1](#), does not resolve this inconsistency.

Items such as controls and vent housings shall be ignored, as shall other features or protrusions with a volume of less than 2 l.

## E-2.2 Unfrozen Compartments

Except as set out in [E-2.4](#), three air temperature sensors in unfrozen compartments shall be located at the following vertical positions defined by the h-line (from the bottom):

- a) At  $3/4 h$  ( $TMP_1$ );
- b) At  $1/2 h$  ( $TMP_2$ ); and
- c) At 50 mm ( $TMP_3$ ).

These positions are illustrated in [Fig. 11](#), [Fig. 12](#), [Fig. 13](#) and [Fig. 17 \(a\)](#), and with reference to [E-2.4](#), as applicable.

A box evaporator of any shape within an unfrozen compartment where the evaporator is not configured to provide a separate storage space (that is, not a sub-compartment) shall be treated as if it were a convenience feature [see [Fig. 12 \(c\)](#)].

## E-2.3 Frozen Compartments

Except as set out in [E-2.4](#), either five or seven air temperature sensors in frozen compartments shall be located in vertical positions as follows:

- a) Two at 50 mm from the top surface of the compartment ( $TMP_{12}$  front and  $TMP_{13}$  rear);
- b) At  $3/4 h$  from the bottom defined by the h-line if  $h_1$  exceeds 1 000 mm ( $TMP_{16}$ );
- c) At  $1/2 h$  from the bottom defined by the h-line ( $TMP_{11}$ );
- d) At  $1/4 h$  from the bottom defined by the h-line if  $h_1$  exceeds 1 000 mm ( $TMP_{17}$ ); and
- e) Two at 50 mm from the bottom surface of the compartment ( $TMP_{14}$  front and  $TMP_{15}$  rear).



For TMP<sub>12</sub>, TMP<sub>13</sub>, TMP<sub>14</sub>, and TMP<sub>15</sub>, the vertical distance is measured at the local position of the sensor in the horizontal plane.

Eliminate TMP<sub>13</sub> if the clearance between TMP<sub>12</sub> and TMP<sub>13</sub> is less than 25 mm and eliminate TMP<sub>15</sub> if the clearance between TMP<sub>14</sub> and TMP<sub>15</sub> is less than 25 mm. These positions are illustrated in Fig. 14, Fig. 15, Fig. 16, Fig. 17, and Fig. 18, and with reference to E-2.4, as applicable.

## E-2.4 Equivalent Positions and Other Requirements for all Compartment Types

### E-2.4.1 General

The equivalent sensor locations for special configurations (or features) and other requirements for all compartment types are set out below.

If it is not possible to place sensors in the positions shown in Fig. 11 to Fig. 18, the first option is to use a mirror image of the positions, as applicable, as illustrated in Fig. 19.

Where it is not possible to place the temperature sensors in one of these positions, they shall be positioned as near as practicable to the specified locations in a position which will provide an equivalent result, taking note of the intent above. The position of such locations shall be recorded in the test report.

### E-2.4.2 Compartment Full Height

The full height of a compartment ( $h_1$ ) is defined as the height at the front of the compartment or sub-compartment adjacent to the door seals from the bottom to the top. When the liner at the door seal is curved, the inner radius shall be taken as reference (see Fig. 16). For top-opening compartments, the full height is taken from the lowest bottom surface to the gasket sealing surface.

### E-2.4.3 Compartment Depth

TMP<sub>1</sub>, TMP<sub>2</sub>, and TMP<sub>3</sub> for unfrozen compartments, except for small or low-height compartments, and TMP<sub>11</sub>, TMP<sub>16</sub>, and TMP<sub>17</sub> for frozen compartments, shall be located at the midpoint between the front and back of the compartment at the given vertical position. For all front opening compartments, the front of the compartment is the gasket sealing surface. The back of the compartment is defined as the rear surface at the vertical position of the sensor.

### E-2.4.4 Compartment Width

TMP<sub>1</sub>, TMP<sub>2</sub>, and TMP<sub>3</sub> for unfrozen compartments, except for small or low height compartments, and TMP<sub>11</sub>, TMP<sub>16</sub>, and TMP<sub>17</sub> for frozen compartments, shall be located at the midpoint between the left and right surface of the compartment at the given vertical position.

### E-2.4.5 Small Compartments, Sub-Compartments, or Convenience Features

For a compartment/sub-compartment or convenience feature

where the full height ( $h_1$ ) of the compartment/sub-compartment /convenience feature is not more than 150 mm or the volume is not more than 25 l and where temperature measurements are required, two temperature sensors shall be used. Each shall be located 50 mm from the lower surface of the compartment/sub-compartment/convenience feature, one at the front left and the other at the right rear at  $d/4$  and  $w/4$  (see Fig. 13A).

### E-2.4.6 Low Height Compartments, Sub-Compartments, or Convenience Features

For unfrozen compartments, sub-compartment, or convenience features where the full height ( $h_1$ ) is 300 mm or less, and this is less than 0.7 of either the width (measured at the door sealing surface) or the maximum depth (between the door sealing surface and back wall), the temperature sensors shall be located in positions as shown in Fig. 13B. In cases where the width or depth is greater than 700 mm, the positions shown in Fig. 13B shall also be used if the ratio of full height ( $h_1$ ) to either depth or width is less than 0.6.

For frozen compartments where the full height ( $h_1$ ) is 200 mm or less and the volume is 40 l or less, the temperature sensors shall be located in positions as shown in Fig. 13B.

### E-2.4.7 Clearance from Internal Fittings (Other Than Shelves)

Except where otherwise specified, the clearance of temperature sensors shall be at least 25 mm from any internal fittings, walls, or features. Clearance in this context means the distance from the surface of the internal fitting, wall, or feature to the closest external surface of the temperature sensor (metal mass).

Where a temperature sensor would have less than 25 mm clearance from a fixed sub-compartment/feature that is not full width, the sensor shall be moved so that the specified height is maintained while a clearance of 25 mm is maintained from the surface of the sub-compartment/feature. Where a temperature sensor has to be placed next to a convenience feature that has a gap on each side, the sensor shall be placed in the gap that is the larger. Where the gap sizes are equal, the sensor shall be placed in the left gap for sensor positions that are above the centre of the effective height and on the right gap for sensor positions that are at or below the centre of the effective height. Refer also to Fig. 11 and Fig. 12.

### E-2.4.8 Shelf and Temperature Sensor Placement

The following rules regarding shelf placement shall be applied:

- Shelves shall be installed in accordance with the manufacturer's instructions (where available); and
- Where no positions are specified in manufacturer instructions, where possible, one shelf in the



largest unfrozen compartment type (where applicable) shall be located below temperature sensor position  $TMP_1$  (while maintaining a minimum clearance of 25 mm) and above  $TMP_2$ , and one shelf shall be located below temperature sensor position  $TMP_2$  (while maintaining a minimum clearance of 25 mm) and above  $TMP_3$ . As far as possible, any remaining shelves shall be evenly spaced through the compartment.

The following rules regarding temperature sensor placement shall be applied:

- a) Where the shelves positions are specified or where there is limited adjustability, temperature sensors that have less than 25 mm clearance from the shelf shall be relocated to a position above the shelf with a clearance of 25 mm; and
- b) Where a temperature sensor would have less than 50 mm clearance above or below a refrigerated shelf surface, or any evaporator surface (such as plate or box evaporator) that temperature sensor shall be relocated to a position with 50 mm clearance above the relevant refrigerated shelf, where possible, and shall maintain 50 mm clearance in all horizontal directions.

Door shelves, drawers, bins, sliding baskets, or items with dedicated but interchangeable positions shall all be kept in place but organized to minimize their interference with temperature sensors.

Items which are not intended to be in place during normal use, as specified in the instructions, are removed.

#### **E-2.4.9 Convenience Feature and Temperature Sensor Placement**

Where a convenience feature interferes with the position of a temperature sensor, the same rules as for part width compartments (see [E-2.4.7](#)) and for shelves (see [E-2.4.8](#)) apply. If the sensor in the compartment lies in the convenience feature, it shall be moved to the nearest position outside it.

#### **E-2.4.10 Frozen Compartment Sensors and Door Shelves**

Where a deep door shelf interferes with or encloses the location for sensor positions  $TMP_{12}$  or  $TMP_{14}$ , (refer to [Fig. 15](#) and [Fig. 16](#)) or the air space clearance is less than 25 mm, then the centre line of the sensor shall be moved by up to 50 mm further into the compartment (that is, a maximum depth of 150 mm from the door gasket) in order to satisfy the clearance. If this does not satisfy the requirements, the sensor shall be located inside the door shelf as close as possible to the original position while maintaining a clearance of 30 mm from the centre of the sensor to the wall and 50 mm from the centre of the sensor to the floor of the door shelf.

Where a two-star section only comprises door shelves, three sensors shall be positioned diagonally, similar to the low-height compartments (see [Fig. 13A](#)). The h-line is to be determined from the bottom surface of the two-star section to the top surface using  $TMP_{23}$  as reference. In the absence of top and/or bottom surfaces, the door or volume borders (see **H-4** of Part 2) shall be taken as the limit for the h-line and sensor positions. The sensor positions shall be:

- a)  $TMP_{21}$  at 50 mm from the top surface;
- b)  $TMP_{22}$  at  $1/2 h$  defined by the h-line; and
- c)  $TMP_{23}$  at 50 mm from the bottom surface.

The sensor positions shall be in width direction (if these positions are not available, the sensors shall be shifted to the nearest position at the given height level that maintains minimum clearances):

- a)  $TMP_{21}$  at 50 mm from the section border closest to the hinge;
- b)  $TMP_{22}$  at the midpoint measured at the height level  $1/2 h$ ; and
- c)  $TMP_{23}$  at 50 mm from the section border at the opposite side from  $TMP_{21}$ .

In the depth direction, the three sensors shall be placed at the midpoint where the depth is measured from the door surface to the volume border, this for each sensor at its corresponding height level.

If a three-star or four-star compartment has multiple doors, a two-star section contained in it shall not cover multiple doors. If required, a two-star section can be defined in each door.

#### **E-2.4.11 Placement of Temperature Sensors within Drawers and Bins**

Where a drawer or bin is located at the top of the compartment, the effective height ( $h$ ) shall be taken from the lowest fixed point above the drawer or bin as it slides in and out (effectively equal to the top of the tallest object that could be placed into the drawer or bin without catching).

Where a temperature sensor is required within or in the vicinity of a drawer or bin, the sensor shall be located inside the drawer or bin, and the drawer or bin shall be treated as the inside of the liner ([Fig. 18](#)). Effectively, this means that the effective height ( $h$ ) shall be taken from the bottom of the lowest drawer or bin.

When drawers and/or bins wholly or predominantly occupy the space within a compartment, sensors shall be placed within these drawers or bins in positions specified in [E-2.2](#) or [E-2.3](#), as applicable. In the case of solid drawers or bins, temperature sensors shall lie inside the relevant drawer or bin (see [E-2.4](#)) while maintaining all clearances (see [E-2.4.7](#)) and treating the base of the bin as a shelf (see [E-2.4.8](#)).

Where the available space is so small that the clearances specified cannot be achieved, the clearance from the temperature sensor to the bin bottom (25 mm) shall be maintained as far as possible while reducing the clearance to the compartment top.

The positions of temperature sensors within drawers and bins are illustrated in [Fig. 18](#).

If a space within the compartment or sub-compartment is covered with an inner door (flap), the placement of the sensors shall follow the procedure as given for bins or drawers.

### **E-2.5 Consideration of Convenience Features**

For the purposes of the tests in this document, a convenience feature is not subject to the temperature measurement requirements that apply to sub-compartments. However, this is conditional upon the requirement that the sum of the volumes of:

- a) Fixed convenience features in a compartment shall not exceed 25 percent of the compartment volume; and
- b) The sum of fixed and removable convenience features in a compartment shall not exceed 40 percent of the compartment volume.

Where the volume of convenience features in any compartment exceeds these limits, a sufficient number of fixed convenience features shall be selected and deemed to be sub-compartments (and therefore classified and tested accordingly) until the above volume requirement on convenience features is met according to the following rules:

- a) Firstly, those with separate temperature controls (including those with 2 position controls) in decreasing size order; and
- b) Those without separate temperature controls in decreasing size order.

Where the above rules give two or more convenience features an equal ranking, the first selected shall be the one farthest from the centre of the space in which compartment temperature sensors are located.

Details of temperature-control setting for convenience features are set out in [C-2.5.3](#).

Where a compartment consists wholly or mainly of drawers and/or bins, these generally would not all be considered as convenience features.

## **E-3 COMPARTMENT AVERAGE AIR TEMPERATURES DETERMINATION**

### **E-3.1 General**

For each compartment, the average air temperature at each sensor location is determined. These temperatures are then combined to determine the compartment temperature.

### **E-3.2 Determination of the Average Temperature of a Sensor over a Period**

The average temperature of a sensor over a period shall be determined by integration. More frequent sampling for selected periods during the test may be used. For example, higher frequency sampling may be useful for short duration events. If it is necessary to combine data with dissimilar sampling rates, each data point shall be weighted in proportion to its relevant sampling period.

### **E-3.3 Determination of the Temperature of a Compartment**

The temperature of a compartment shall be determined over the applicable temperature determination period.

### **E-3.4 Calculation of Temperature Average**

The compartment temperature shall be the arithmetic mean of the temperatures for all temperature sensors in the compartment

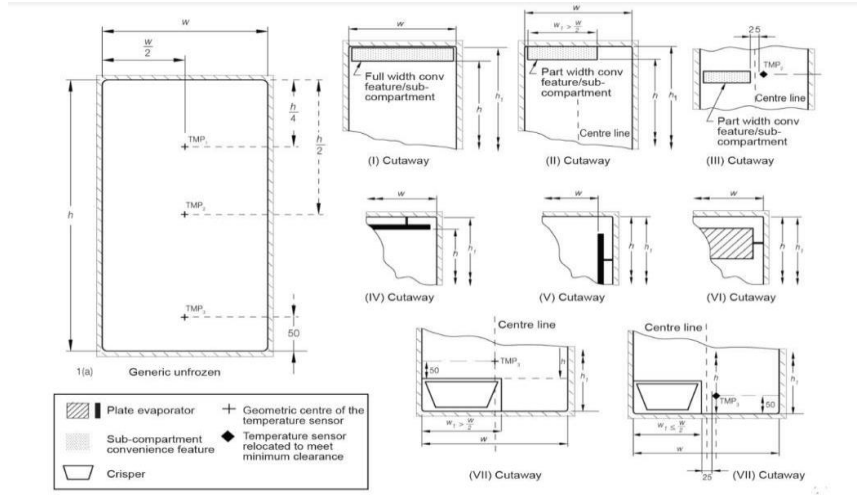

All dimensions are in millimetres.

FIG. 11 AIR-TEMPERATURE MEASURING POINTS – UNFROZEN COMPARTMENTS WITH PLATE OR CONCEALED EVAPORATORS AND EFFECTIVE HEIGHT AND WIDTH EXAMPLES (ALL FRONT VIEWS)

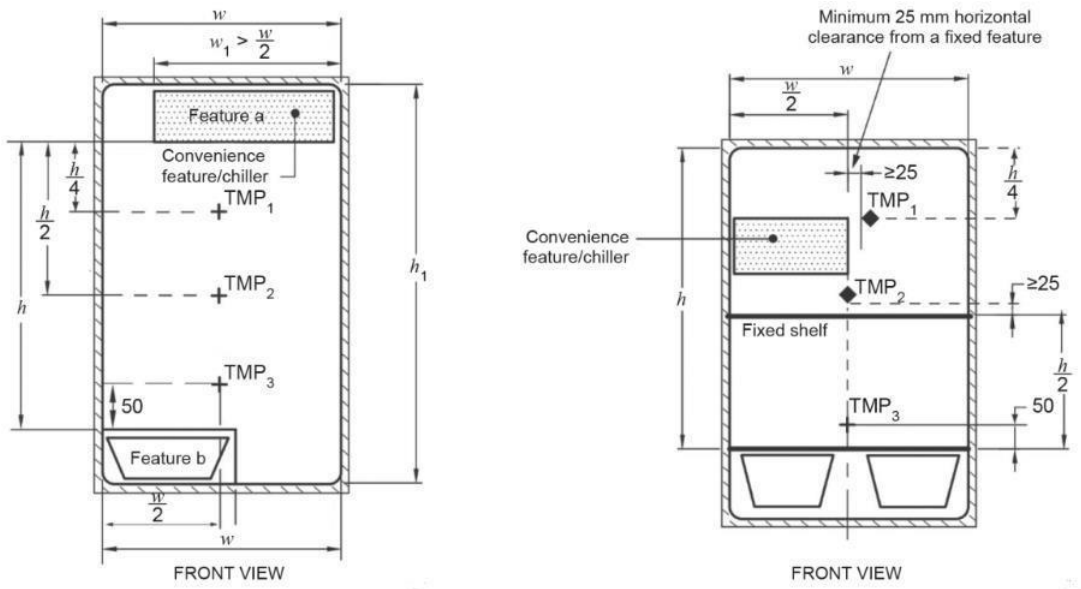

Example 1 Generic with part width crisper, Chiller at top

Example 2 Generic with crisper – relocation of temperature sensors to maintain clearances

All dimensions are given in millimetres.

12A EXAMPLES OF GENERIC COMPARTMENTS WITH CRISPER AND CONVENIENCE FEATURES

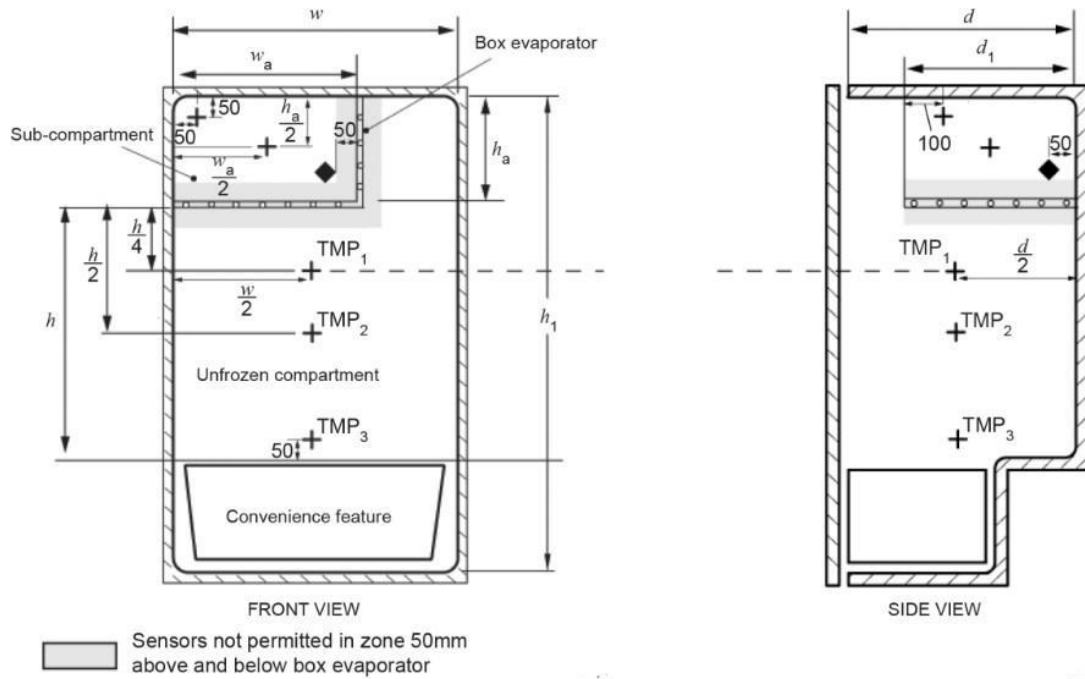

This example shows where the inside of the box evaporator is a sub-compartment, so the temperature is separately measured. This example is a low height compartment.

12B BOX EVAPORATOR AS A SUB-COMPARTMENT

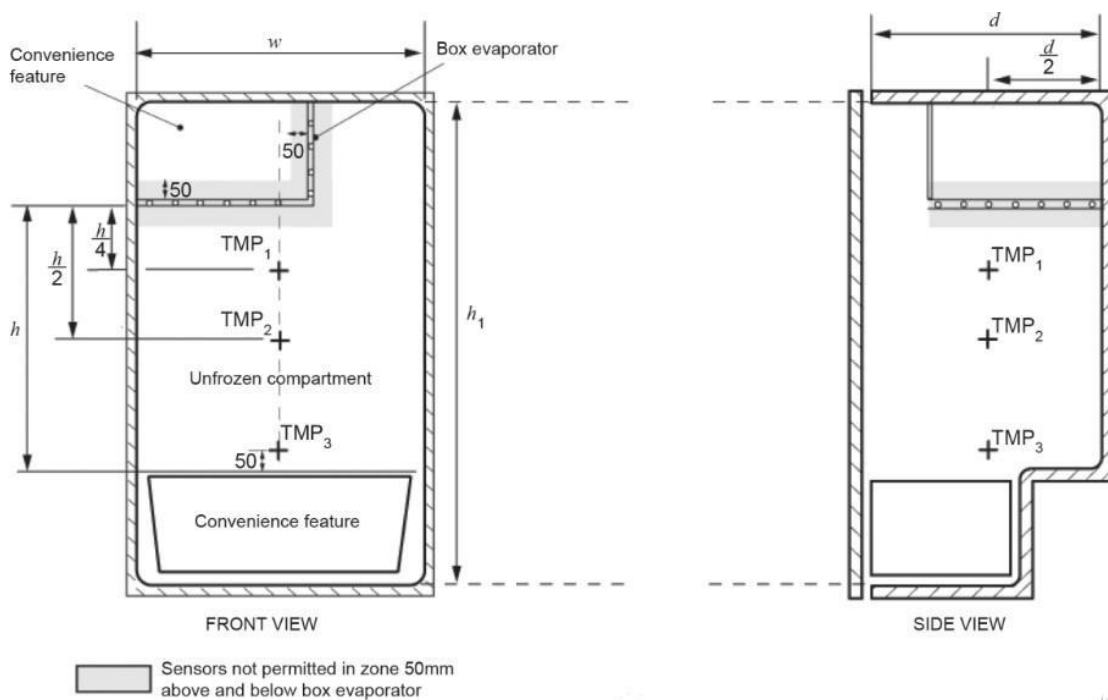

This example shows where a box evaporator is a convenience feature, so the temperature of the convenience is not separately measured unless required to meet the requirement of E-2.5.

12C BOX EVAPORATOR TREATED AS A CONVENIENCE FEATURE

FIG. 12 AIR-TEMPERATURE MEASURING POINTS – UNFROZEN COMPARTMENTS

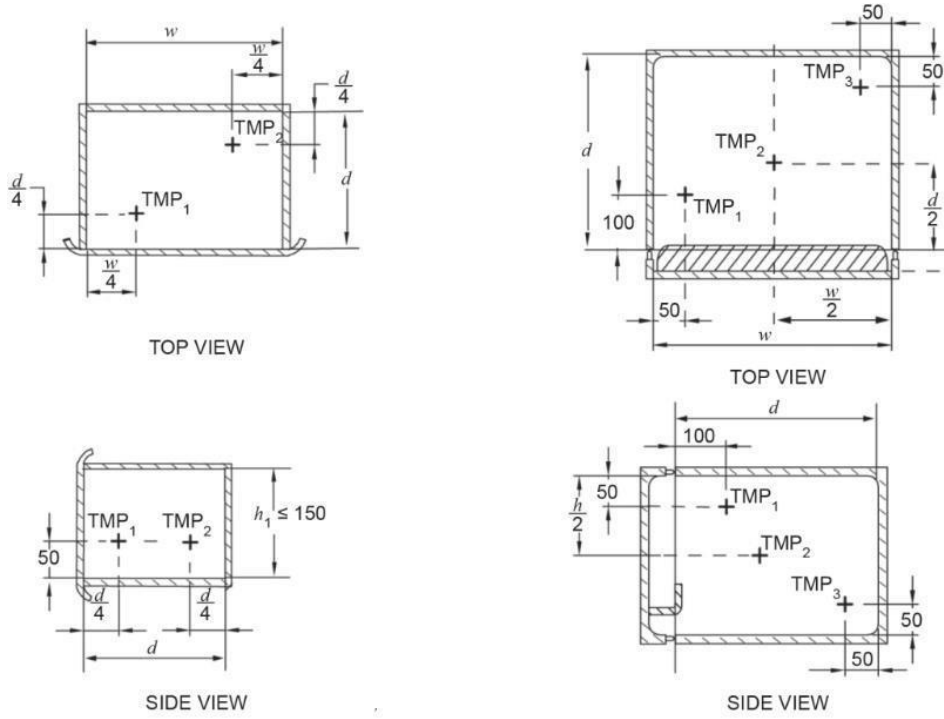

13A SMALL SUB COMPARTMENTS (See [E-2.4.5](#)) 13B LOW HEIGHT COMPARTMENT (See [E-2.4.6](#))  
 FIG. 13 AIR-TEMPERATURE MEASURING POINTS – SMALL (SUB-) COMPARTMENTS AND LOW-HEIGHT (SUB) COMPARTMENTS

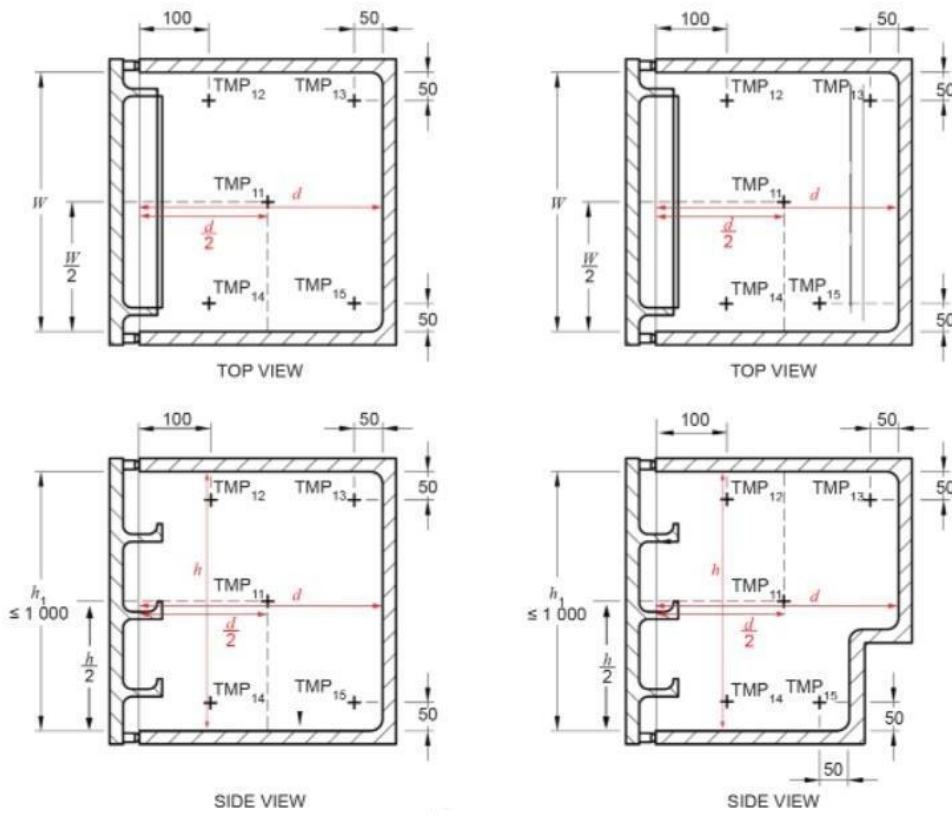

All dimensions in millimetres.

FIG. 14 LOCATION OF TEMPERATURE SENSORS WITHIN UPRIGHT FROZEN COMPARTMENTS WITHOUT REFRIGERATED SHELVES AND WITH HEIGHT EQUAL TO OR LESS THAN 1 000 mm

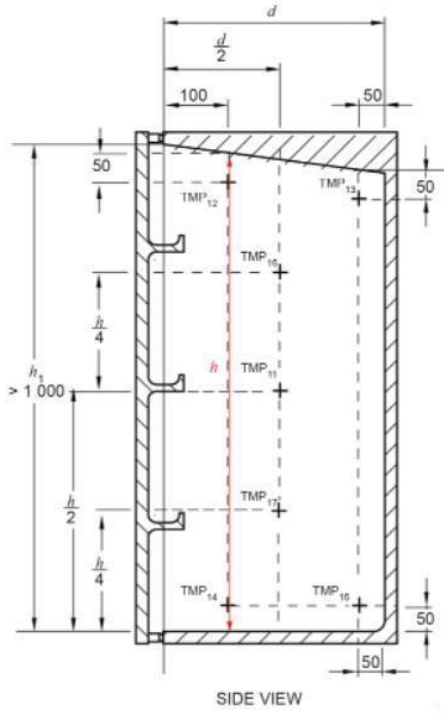

15A TYPE 1 – WITHOUT COMPRESSOR STEP  
PARALLEL FRONT AND BACK, SLOPING TOP

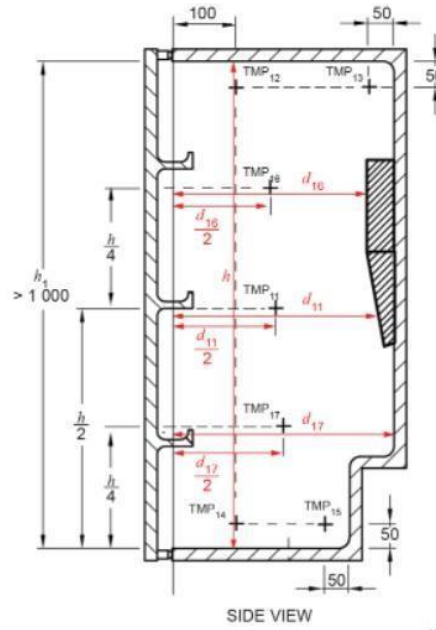

15B TYPE 2 – WITH COMPRESSOR STEP  
UNEVEN SHAPE AT BACK, FLAT TOP

FIG. 15 LOCATION OF TEMPERATURE SENSORS WITHIN UPRIGHT FROZEN COMPARTMENTS  
WITHOUT REFRIGERATED SHELVES AND WITH HEIGHT GREATER THAN 1 000 mm

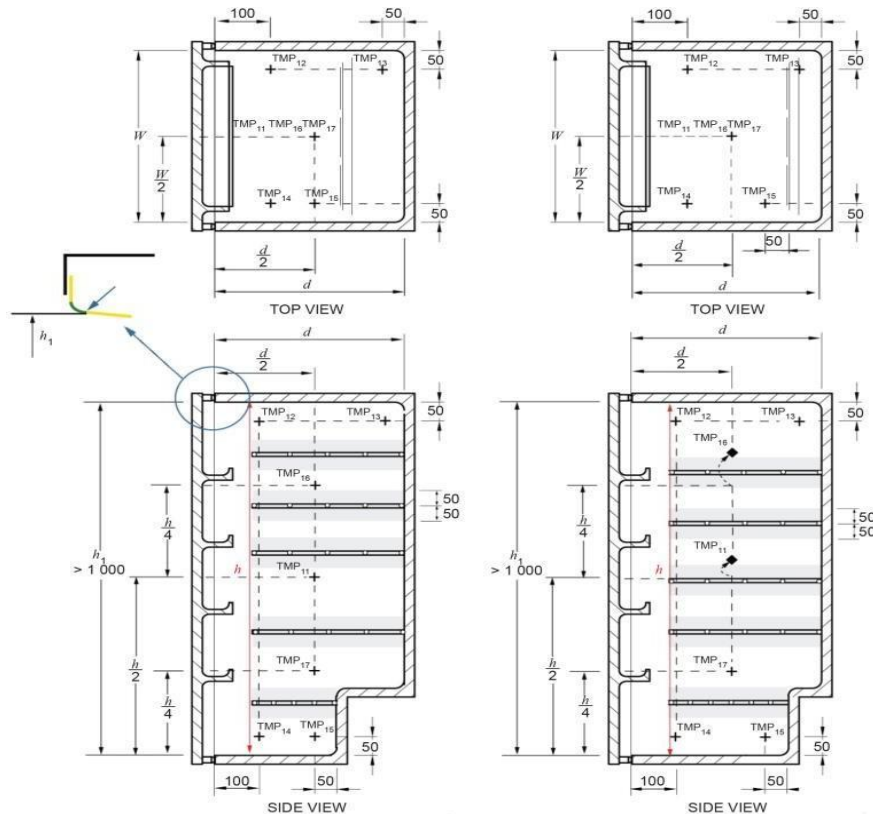

16A REFRIGERATED SHELVES – SPACING DOES  
NOT AFFECT SENSOR LOCATION

16B REFRIGERATED SHELVES – SPACING AFFECT  
SENSOR LOCATION

Moved sensor position – original position not permitted within 50 mm of refrigerated shelves. Sensors not permitted in zone 50 mm above and below refrigerated shelves.

FIG. 16 LOCATION OF TEMPERATURE SENSORS WITHIN UPRIGHT FROZEN COMPARTMENTS  
WITH REFRIGERATED SHELVES AND WITH HEIGHT GREATER THAN 1 000 mm

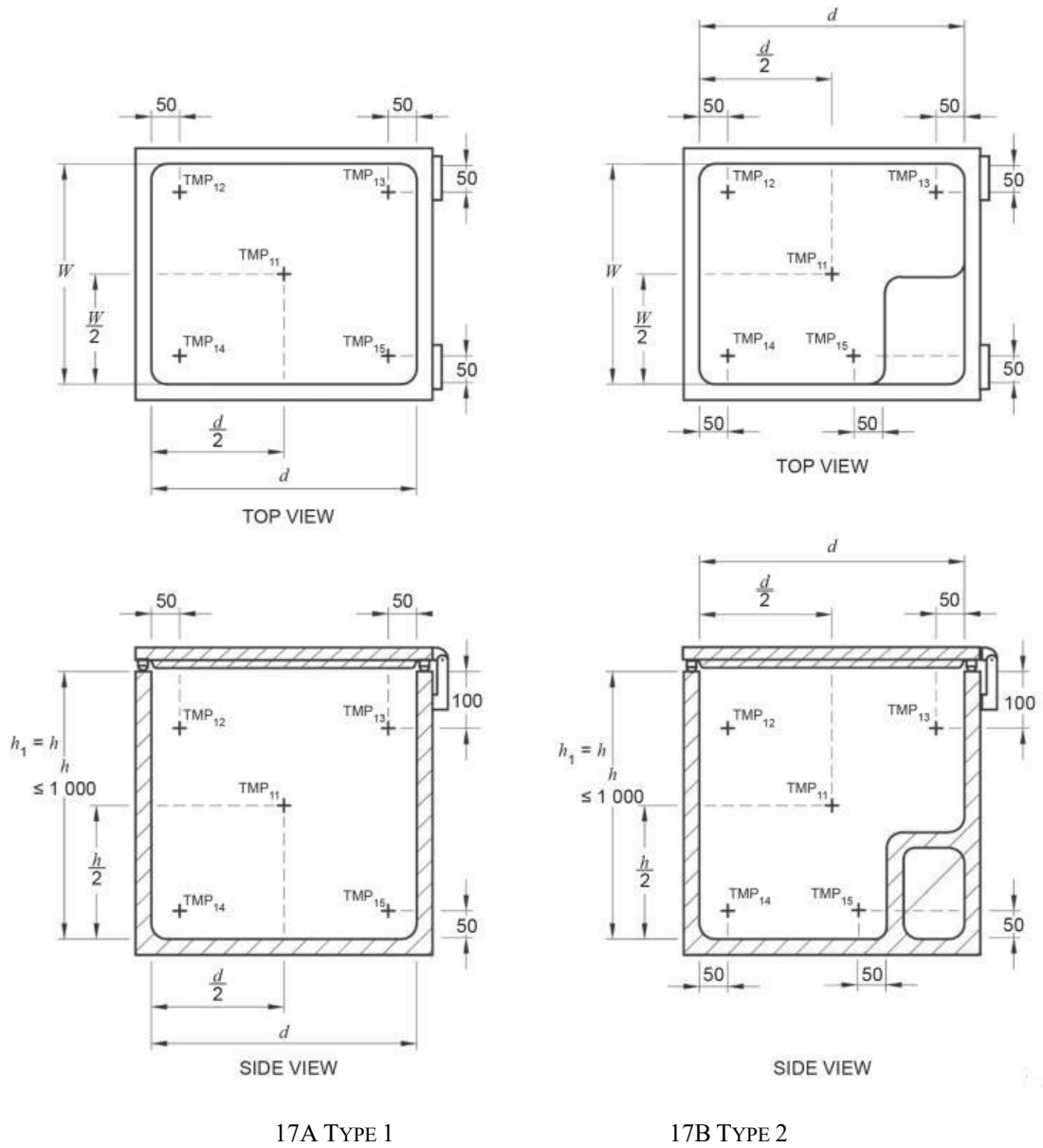



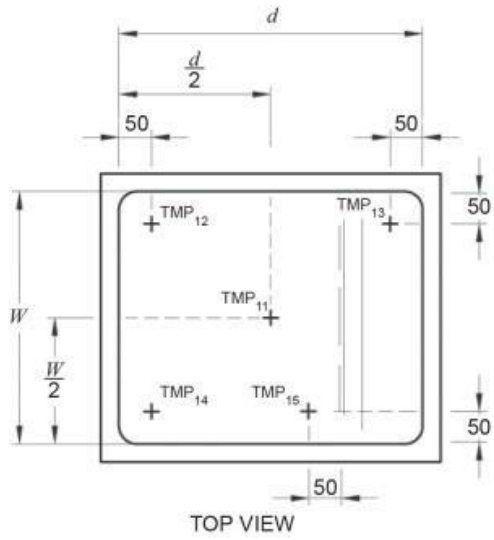

17C TYPE 1

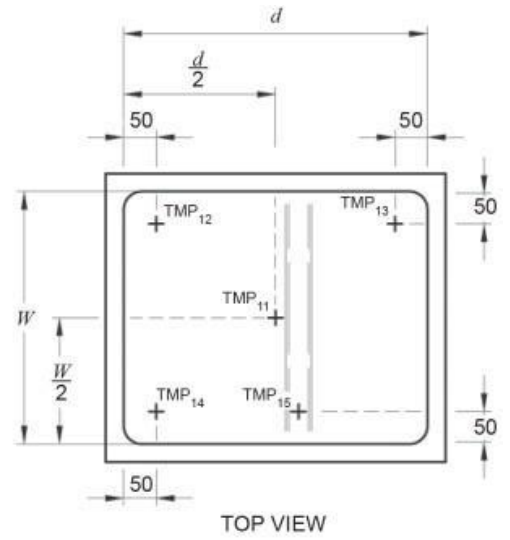

17D TYPE 2

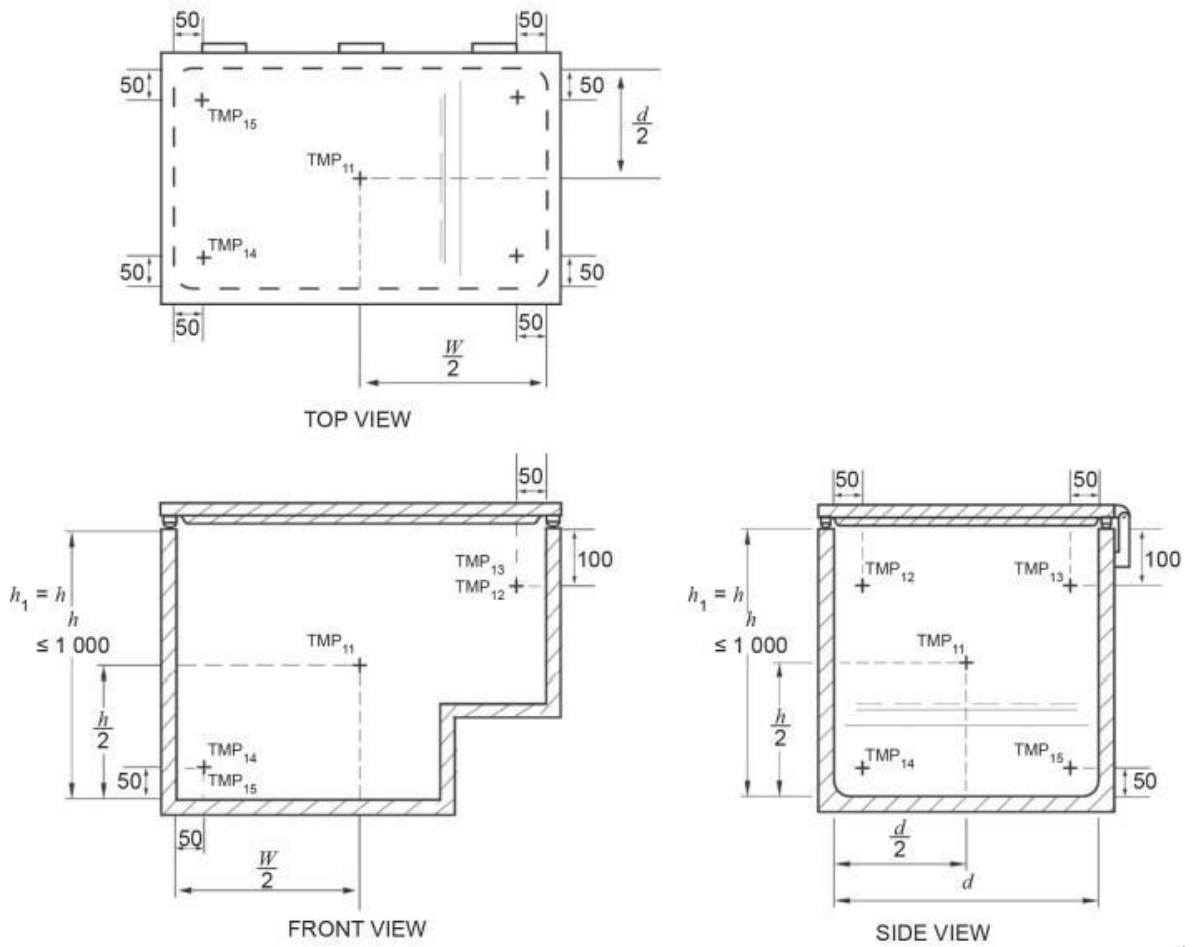

17E TYPE 5

Mirror positions are used because the compressor step is on the right-hand side.

FIG. 17 LOCATION OF TEMPERATURE SENSORS WITHIN CHEST FREEZERS

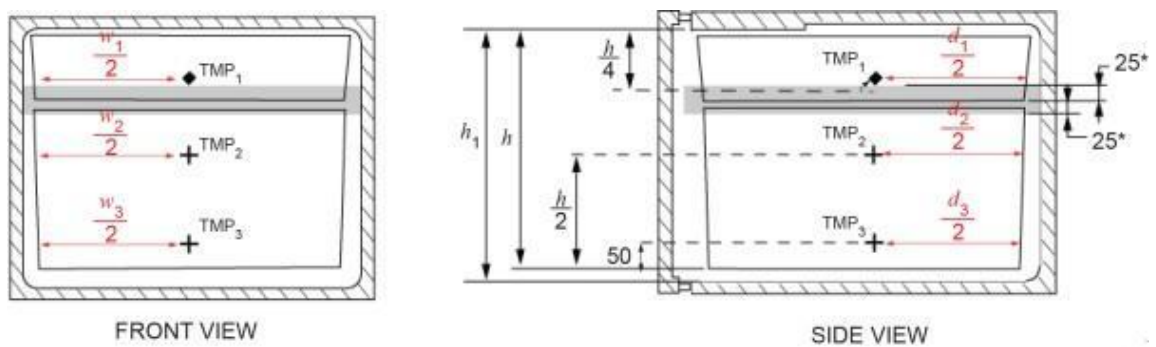

18A SENSOR TMP1 RELOCATED CLEARANCE TO DRAWER LINER (UNFROZEN)

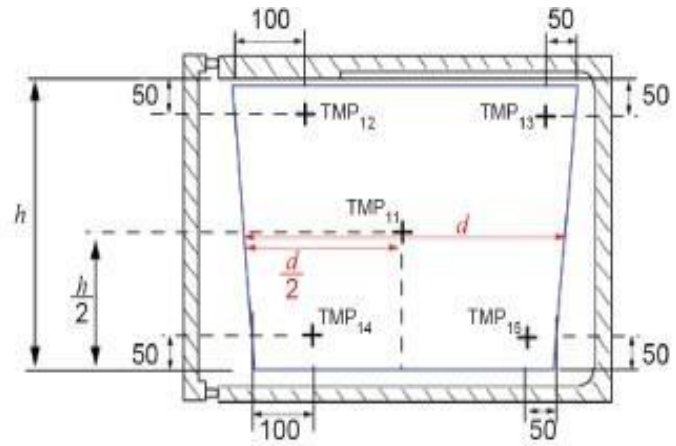
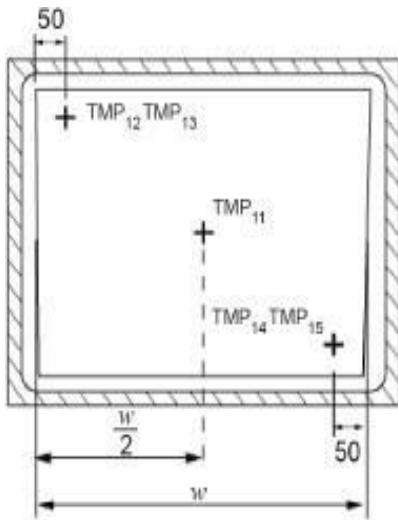

18B TEMPERATURE SENSOR POSITIONS INSIDE A DRAWER OR BIN (FREEZER)

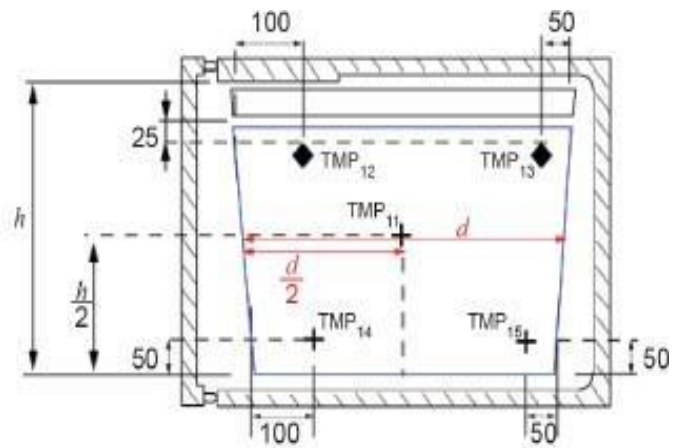
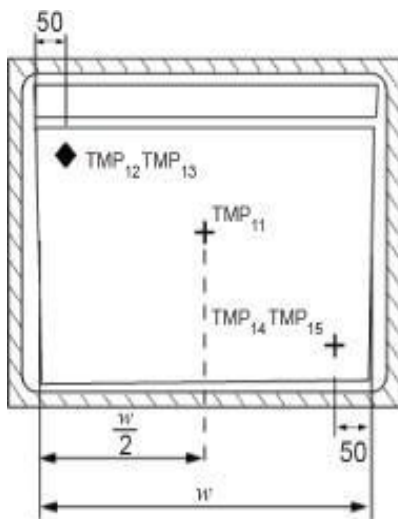

18C LOCATION OF TOP TEMPERATURE SENSORS WHERE UPPER DRAWER HEIGHT IS SUCH THAT THE CLEARANCE OF THE TEMPERATURE SENSOR CANNOT BE MET

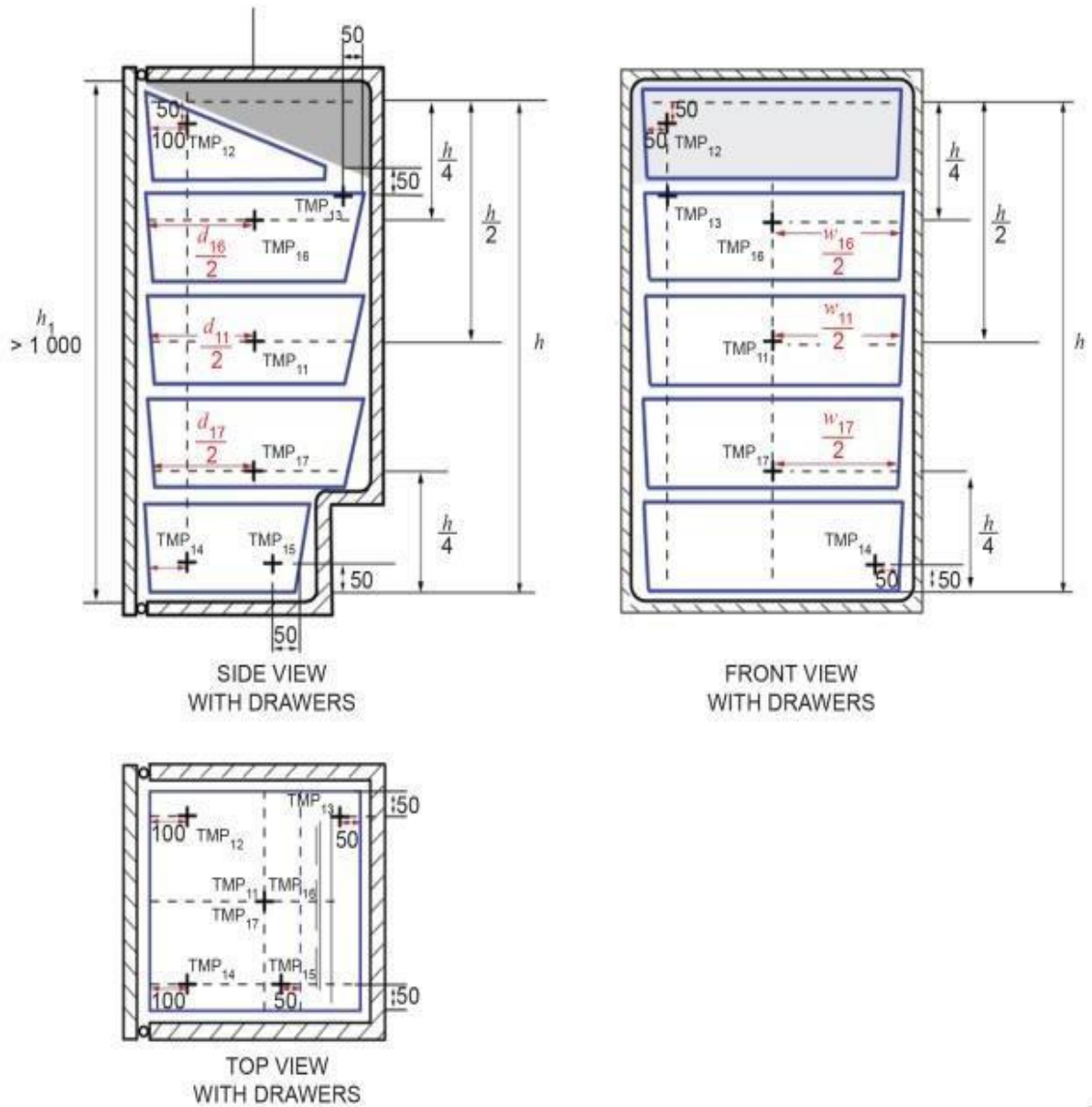

18D UPRIGHT FREEZER WITH INCLINED TOP

FIG. 18 LOCATION OF TEMPERATURE SENSORS WITHIN DRAWERS AND BINS

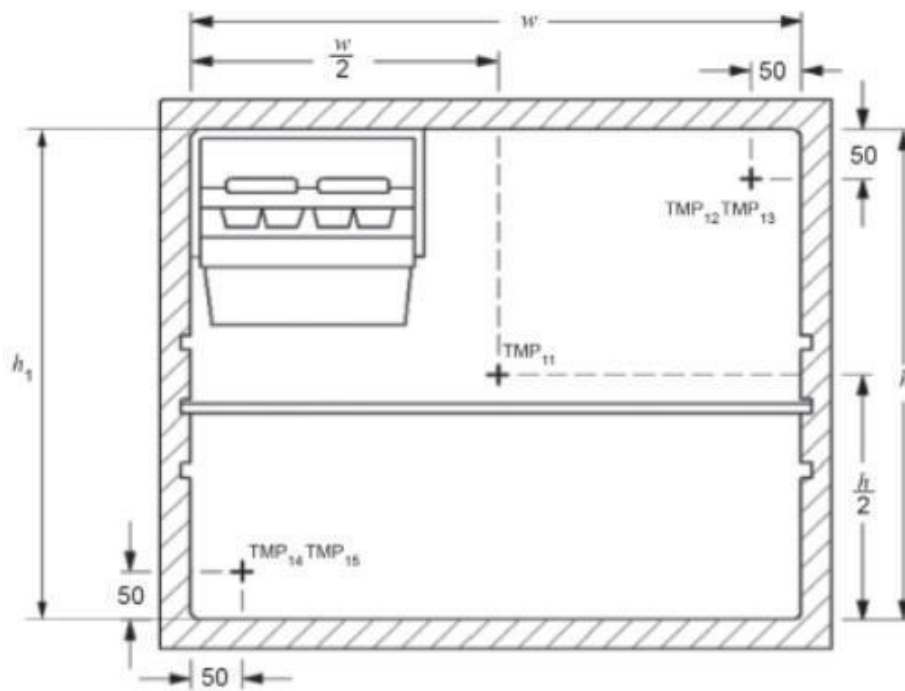

FIG. 19 LOCATION OF TEMPERATURE SENSORS WHEN MIRROR IMAGE IS APPLICABLE

ANNEX F

(Clause 5.2)

DETAILS OF IDENTIFICATION SYMBOLS

The details of identification symbols for frozen compartments are given in Fig. 20 and Fig. 21.

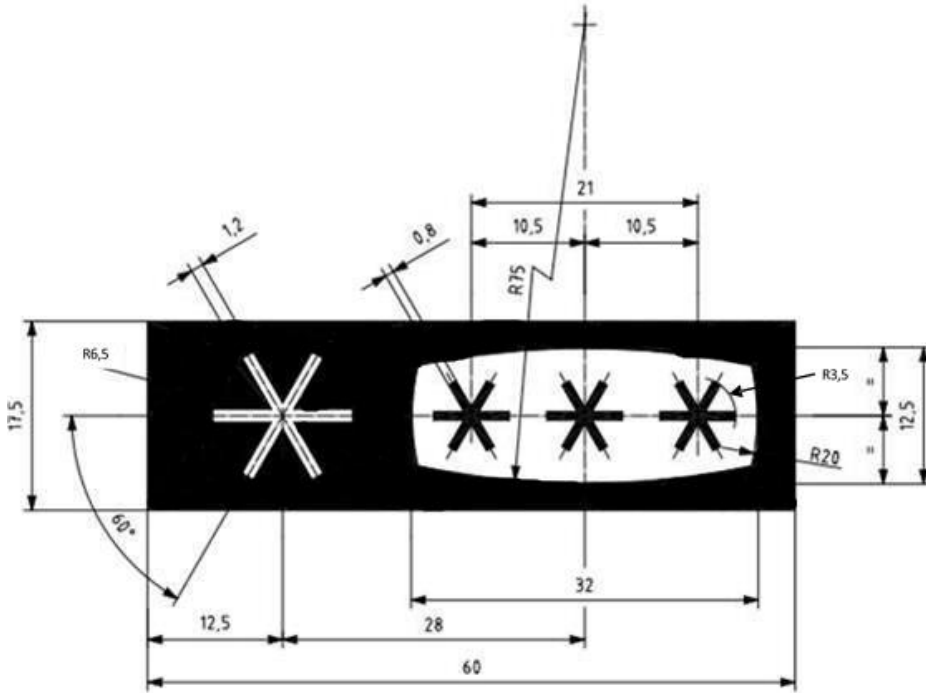

All dimensions in millimetres.

Dimensions are given for information; they may be reduced, while maintaining the same proportions, but the symbol height shall not be less than 5 mm.

FIG. 20 DETAILS OF IDENTIFICATION SYMBOLS FOR FOUR-STAR COMPARTMENTS

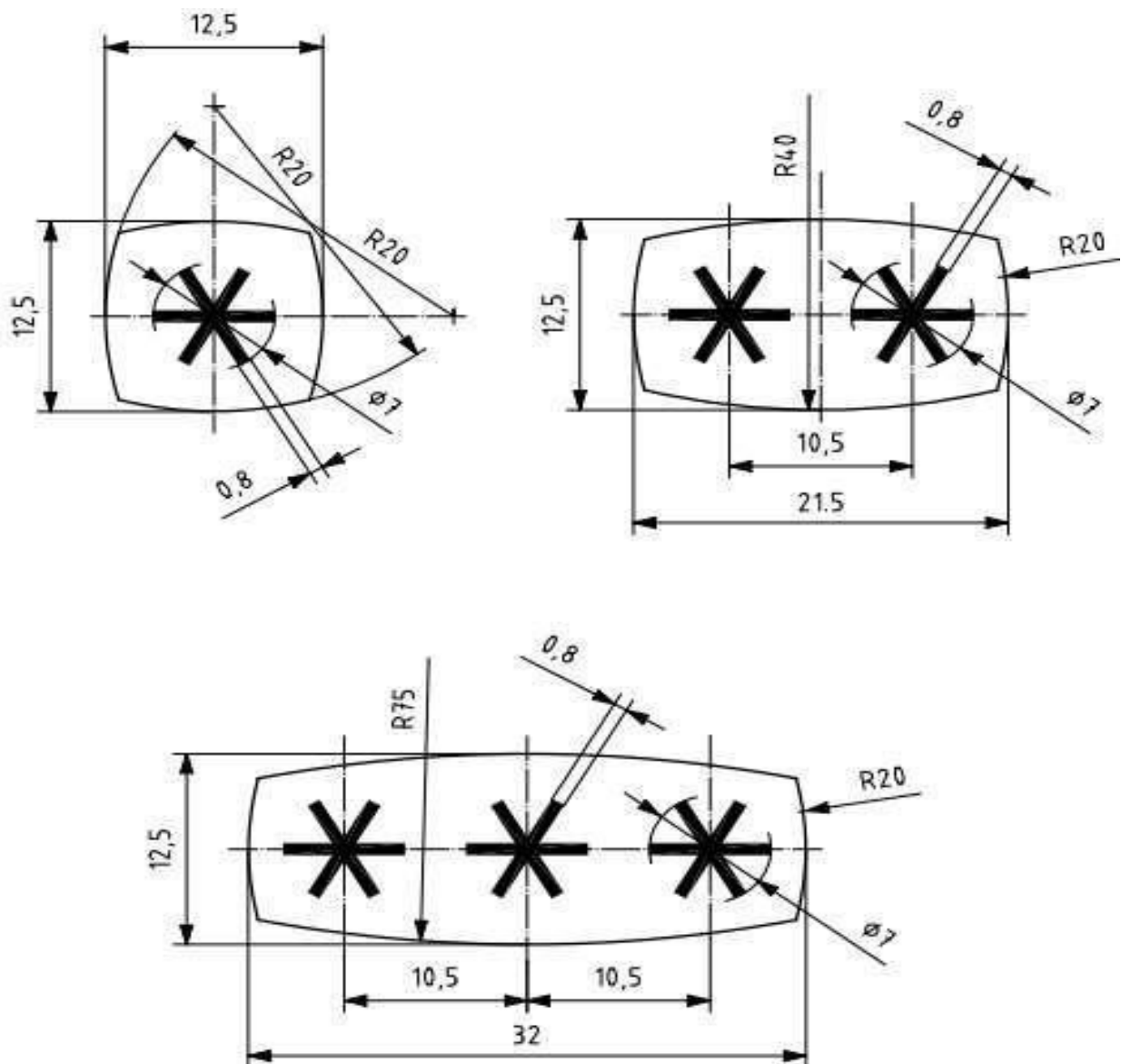

All dimensions in millimetres.

Dimensions are given for information; they may be reduced, while maintaining the same proportions, but the symbol height shall not be less than 5 mm.

FIG. 21 DETAILS OF IDENTIFICATION SYMBOLS FOR FROZEN COMPARTMENTS (EXCEPT FOUR-STAR)



## ANNEX G

*(Foreword and Clause 1.2)*

## ITEMS THAT MAY BE INCLUDED IN A TEST REPORT

The purpose of this Annex is to provide test laboratories, regulators, and consumers groups a comprehensive check list of items that could be included in formal test reports for refrigerating appliances, as well as information that could be included in other sorts of reporting. It also suggests information that should be held by test laboratories after testing. This Annex lists every possible test in the relevant standards that is (Part 1 to Part 3), and the information in this Annex has been extracted from the relevant parts of these standards for easy reference.

Under normal circumstances, only a limited subset of tests would be conducted on a specific appliance when testing to meet the requirements of a particular country, region or client. Only the tests that are required and undertaken for a specific country, region, or client should be included in a test report. Countries or regions are also likely to have different requirements with respect to the test elements that are to be included in formal test reports, so the content of a specific test report needs to reflect both the range of tests undertaken and the specific requirements regarding the local content of the test report.

**G-1** to **G-5** below would normally be included in most test reports as these describe the test laboratory, the relevant standards and details of the product being tested. It is also expected that the relevant test results summary included in numbered item 6 (summary of testing) would be included in most test reports, noting that most countries or regions may only require a limited sub-set of these tests.

It is expected that **G-7** (detailed test results) would be held by the test laboratory in most circumstances. The raw data used to derive the test results would normally also be retained.

**G-1 TESTING LABORATORY**

- a) Laboratory address;
- b) Contact details;
- c) Test officer;
- d) Date(s) of specific tests; and
- e) Relevant accreditation(s) (where applicable).

**G-2 CLIENT****G-3 TEST STANDARDS**

- a) Test standards and editions used;
- b) Document any permitted variations;

- c) Document any non-conformance or deviations; and
- d) Regional or regulatory standard applicable.

**G-4 REFRIGERATING APPLIANCE**

- a) Test item description;
- b) Brand (trademark);
- c) Manufacturer;
- d) Model;
- e) Serial number(s);
- f) Rated voltage and frequency;
- g) Climate class;
- h) Ratings and marking plates, including photographs;
- j) Refrigerant; and
- k) Product characteristics:
  - 1) Type of refrigerating appliance (refrigerator/refrigerator-freezer/freezer/wine storage/other);
  - 2) Built-in appliance or not;
  - 3) Frost-free or not;
  - 4) Defrost controller type (variable, run-time, fixed time, other);
  - 5) Compressor details (single speed, variable speed, multiple compressors);
  - 6) Condenser type [grill (stack)/skin (smooth wall)/fan forced (including direction of the exhaust)/other, as applicable];
  - 7) Condenser location (back/side/underneath, as applicable);
  - 8) Features (chill compartment/automatic icemaker/through the door ice and/or water dispenser/other);
  - 9) For variable defrost controls, min and max defrost interval (where known);
  - 10) For ambient controlled anti-condensation heater, operation map as per Annex G of Part 2 of this standard;
  - 11) For user controlled anti-condensation heaters, describe the switch and any associated controls; and

- 12) Rated linear dimensions (mm) (width × depth × height):
- i) Overall dimensions;
  - ii) Space required in use; and
  - iii) Overall space required in use.

### G-5 LIST OF COMPARTMENTS

List of all compartments and sub-compartments, including:

- a) Compartment type as specified in [3.3](#) (in the case of a variable temperature compartment, also specify the warmest and coldest compartment type that can be selected and the compartment type selected for the primary configuration);
- b) Rated volume in litres;
- c) Defrost type (manual defrost/cyclic defrost/frost-free);
- d) Number of external doors;
- e) Access (top/front/drawer/internal);
- f) Temperature control description (where applicable); and
- g) Total rated volume of all compartments.

### G-6 SUMMARY OF TESTING

- a) Storage test results — For each ambient temperature tested, indicate whether the product complies;
- b) Cooling capacity test — Where applicable, indicate cooling time (hours) for each fresh food compartment;
- c) Freezing capacity test — Where applicable, indicate freezing capacity (kg/12 h) for each three-star or four-star compartment tested and whether four-star requirements are achieved;
- d) Ice making capacity test — Where applicable, indicate ice making capacity (kg/24 h) for an automatic ice maker;
- e) Pull down test — Where applicable, indicate the time for each compartment to reach the specified pull-down temperatures and the ambient temperature for the test;
- f) Energy consumption — Values at 16 °C:
  - 1) Daily energy consumption daily (Wh/day);
  - 2) Defrost interval used to determine each daily energy consumption value, where applicable and how this was determined;
  - 3) Where interpolation has been used to determine daily energy consumption,

indicate the method used. Additional energy for ice making  $\Delta E_{\text{kg-ice}}$  (Wh/kg ice), where applicable;

- 4) Load processing energy input  $E_{\text{input-nominal}}$  (Wh), where applicable;
  - 5) Load processing efficiency load, ambient (W/W), where applicable;
  - 6) Regional values can be reported where applicable;
  - 7) Days at each ambient temperature;
  - 8) Mass of ice to be made (in kg);
  - 9) Load processing factors (load in Wh or factor 'a');
  - 10) Load processing energy;
  - 11) Additional power associated with ambient controlled anti-condensation heaters (noting that this requires use of a regional humidity-temperature distribution) including climate profile adopted for calculations; and
  - 12) Total energy consumption, E (total).
- g) Dimensions and volume;
- 1) Measured linear dimensions (mm) (width × depth × height):
    - i) Overall dimensions;
    - ii) Space required in use; and
    - iii) Overall space required in use.
  - 2) List of all compartments and sub-compartments including:
    - i) Compartment type; and
    - ii) Measured volume in litres.
  - 3) Total measured volume (sum of all compartments).

### G-7 DETAILED TEST RESULTS

#### G-7.1 Instrumentation, Setup, and Temperature Sensors

Provide relevant information on the following items:

- a) Instruments and measurement equipment in accordance with [Annex B](#) of IS 17550 (Part 1);
- b) Test room and appliance set-up in accordance with [Annex C](#) of IS 17550 (Part 1);
- c) Test packages used in accordance with [Annex D](#) of IS 17550 (Part 1);
- d) Location of air temperature sensors in accordance with [Annex E](#) of IS 17550 (Part 1); and

## IS 17550 (Part 1) : 2024

- e) Specific setup and configuration for energy testing in accordance with [Annex B](#) of IS 17550 (Part 1).

All test results should be in accordance with the standard specifications. Any deviation from the requirements specified in the standard in terms of testing conditions or product performance shall be reported against the relevant result, where applicable.

### G-8 IS 17550 (PART 2) PERFORMANCE REQUIREMENTS

#### G-8.1 Storage Tests (See 6 of Part 2)

Indicate ambient temperatures in which storage tests have been undertaken (10 °C, 16 °C, 32 °C, 38 °C, 43 °C).

For each ambient temperature, include information on:

- a) Setting(s) of any user-adjustable control device(s) and any other user-adjustable control(s), damper(s);
- b) For each unfrozen compartment [except chill compartment(s)], the temperature of each air temperature sensor and the average temperature in the compartment;
- c) For each chill compartment, the warmest, and coldest value of each sensor and the average temperature in the compartment (M-packages); and
- d) For each frozen compartment (M-packages):
  - 1) The highest maximum temperature (°C);
  - 2) The duration of the temperature deviation above – 18 °C (or – 12 °C as applicable) (hours);
  - 3) The duration of the defrost control cycle (hours);
  - 4) For period E, the average and maximum of  $T_{fi}$  for each sensor; and
  - 5) For period S, the average and maximum of  $T_{fi}$  for each sensor.
- e) A diagram of the storage plan showing location of test packages and M-packages; and
- f) A diagram or tabulation of the location of the M-package with the highest maximum temperature in each of these compartment, and the location of the M-package with the highest maximum temperature during any temperature deviation as a result of the defrost control cycle.

#### G-8.2 Cooling Capacity Test (See 7 of Part 2)

- a) Load mass (kg);
- b) Volume of the fresh food compartment (litres);

- c) Cooling time (hours);
- d) Any shelf, drawer, or bin positions that differ from those specified;
- e) Any package positions which differ from those specified; and
- f) Settings of any ‘quick cooling’ functions used.

#### G-8.3 Freezing Capacity Test (See 8 of Part 2)

- a) Total mass of the ballast load (kg);
- b) Mass of the light load (kg);
- c) Freezing time (hours);
- d) Volume of the relevant compartments (litres);
- e) For ballast load of frozen compartment, the maximum temperature (°C) and duration of the deviation (hours);
- f) For fresh food compartment and/or cellar compartment, the highest and lowest value of each sensor;
- g) Settings of all temperature-control devices, include timer(s), if any;
- h) A diagram of the storage plan for the refrigerating appliance showing the location of the M-packages and the location of the warmest M-package(s) for both the ballast load and the light load;
- j) If the refrigerating appliance is fitted with a device intended to set the refrigeration of the freezer compartment into continuous operation when freezing and then to revert to steady state operation automatically, the time that elapsed before it reverted to normal steady state operation;
- k) The freezing time achieved with the light load being at least 3.5 kg of test packages per 100 litres of its volume and in no case less than 2.0 kg;
- m) Whether the freezing time is less than 24 h; and
- n) The specific freezing capacity (kg/12 h).

#### G-8.4 Automatic Ice Making Capacity Test (See 9 of Part 2)

- a) Average fresh food compartment temperature, in °C;
- b) Average freezer compartment temperature, in °C;
- c) Ice making capacity (kg/24 h); and
- d) Temperature-control settings.

#### G-8.5 Pull-Down Test (See Annex A of Part 2)

- a) Ambient temperature selected for the test;
- b) Where applicable, any alternative positions for air

temperature sensors;

- c) Function selected for each multi-use compartment;
- d) Position of each user-adjustable baffle that may affect operating temperatures in any space in the refrigerating appliance;
- e) Settings of all user-adjustable temperature controls;
- f) Setting of all other user-adjustable switches and controls;
- g) Any disconnection, bridging, or modification in any way of any devices for the test;
- h) For each compartment, the start temperature, target temperature, and time to reach target temperature; and
- j) A chart of temperatures in each compartment during the test is recommended.

#### **G-8.6 Wine Storage Appliances and Compartments; Storage Test (See Annex B of Part 2)**

- a) The number of standard bottles that can be accommodated;
- b) For each ambient temperature tested:
  - 1) The ambient temperature, in °C;
  - 2) The ambient relative humidity (percent);
  - 3) The setting(s) of temperature-control device(s) and other controls, if any (if user-adjustable); and
  - 4) The temperature of each sensor and the average temperature in the wine storage compartment.
- c) The average of all temperature amplitudes at each measurement point.

#### **G-8.7 Temperature Rise Test (See Annex C of Part 2)**

- a) The ambient temperature, °C;
- b) The temperature rise time from – 18 °C to – 9 °C (hours); and
- c) A chart of temperatures in each compartment during the test is recommended.

#### **G-8.8 Water Vapour Condensation Test (See Annex D of Part 2)**

- a) A coded sketch showing the running water area appearing during the test on all external surfaces;
- b) Selected test period;
- c) Duration of the period of observation; and
- d) Whether any manual switch or control provided for anti-condensation heaters was switched on or

off or adjusted.

### **G-9 IS 17550 (PART 3) ENERGY CONSUMPTION MEASUREMENTS**

#### **G-9.1 Description of Specific Appliance Setup for Energy Testing (See Annex A of Part 3)**

List any specific configuration or setup requirements that are specific to energy testing.

#### **G-9.2 Steady State Power and Temperature (See Annex B of Part 3)**

For each test undertaken, include details on:

- a) Steady state test identifier;
- b) Nominal ambient temperature, in °C;
- c) Measured ambient temperature, in °C;
- d) Measured ambient relative humidity (percent);
- e) Temperature control settings;
- f) Method of establishing stability (SS1 or SS2);
- g) PSSM (W);
- h) Temperature in each compartment (TSS);
- j) Percentage of compressor run time (percent) (where applicable);
- k) Total test time:  $t_{(end)-Y} - t_{(end)-X}$  (hours);
- m) Time of blocks A, B, and C (where SS1 used); and
- n) PSS (corrected steady state power) (W).

Calculation of SS2 power and temperature requires information about the specific initial defrost event at the start of the SS2 period, which is not recorded in this summary (but should be referenced to the specific defrost and recovery period information in Annex C of Part 3).

A chart showing the key parameters for the selected test periods is recommended.

#### **G-9.3 Defrost and Recovery Energy and Temperature Change (See Annex C of Part 3)**

For each defrost and recovery period included in the test report, include details on:

- a) Defrost identifier;
- b) Nominal ambient temperature, in °C;
- c) Measured ambient temperature, in °C;
- d) Measured ambient relative humidity (percent);
- e) Temperature control settings;
- f) Time since power was last connected (hours);

## IS 17550 (Part 1) : 2024

- g) Date and time at the start of the defrost heater operation;
- h) Length of periods D and F (hours);
- j) Whether any non-default parameters for selection of periods D and F were required to achieve validity requirements;
- k) Spread of power between periods D and F (percent);
- m) Spread of temperatures in each compartment between periods D and F (K);
- n) Incremental defrost and recovery energy consumption  $\Delta E_{df}$  (Wh);
- p) Temperature deviation in each compartment during defrost and recovery  $\Delta T_{hdjf}$  (Kh);
- q) Defrost heater energy  $E_{df-heaterj}$  (Wh);
- r) Fixed defrost adder  $\Delta E_{df-adderj} = \Delta E_{dfj} - E_{df-heaterj}$ ; and
- s) Defrost run time impact (where applicable)  $\Delta t_{drj}$  (hours).

A chart showing the key parameters for the selected defrosts is recommended.

For the representative and valid defrost and recovery periods in each ambient temperature for the product, include details on:

- a) Average incremental defrost and recovery energy consumption  $\Delta E_{df}$  (average) (Wh);
- b) Average temperature deviation in each compartment during defrost and recovery  $\Delta T_{hdjf}$  (Kh);
- c) Average Fixed defrost adder  $\Delta E_{df-adder}$  (Wh); and
- d) Average defrost run time impact (where applicable)  $\Delta t_{dr}$  (hours).

### G-9.4 Defrost Interval (See Annex D of Part 3)

Where the refrigeration appliance has one or more defrost control cycles, describe the tests to verify the type of defrost controller(s) used.

- a) Type of defrost controller and relevant clause (elapsed time, run time, variable, non-compliant variable); and
- b) Estimated defrost interval  $t_{df}$  (hours) at ambient 32 °C.

### G-9.5 Determination of Daily Energy Consumption (See 6 of Part 3)

For each test point selected for each ambient temperature, include details on:

- a) Steady state test identifier (examples, temperature control settings);
- b) Nominal ambient temperature, in °C;
- c) Daily energy consumption  $E_{daily}$  (Wh/day); and
- d) Temperature in each compartment including defrost ( $T_{average}$ ).

### G-9.6 Where Energy is determined by Interpolation (See Annex E of Part 3)

- a) Ambient temperature applicable;
- b) The test points used for interpolation (steady state identifier);
- c) The type of interpolation used and the relevant reference in Annex E of Part 3;
- d) Interpolated energy consumption  $E_{daily}$  (Wh/day); and
- e) Temperature in each compartment at the point of interpolation (C); and
- f) Where applicable, the following parameters:
  - 1) The energy-temperature slope  $S_i$  (see E-3.3) of Part 3;
  - 2) The value of coefficients  $E_0$ ,  $A$  and  $B$  (see E- 4.4) of Part 3; and
  - 3) The value of coefficients  $E_0$ ,  $A$ ,  $B$ , and  $C$  (see E-4.5) of Part 3.

A chart showing the interpolation approach and each result is recommended.

### G-9.7 Energy Consumption of Specified Auxiliaries (See Annex F of Part 3)

### G-9.8 Ambient Controlled Anti-Condensation Heaters (See F-2 of Part 3)

The value of  $R_1$  to  $R_{30}$  that is specified by the country or region. The value of  $P_1$  to  $P_{30}$  that is provided by the client/manufacturer.

- a) The calculated value of  $W_{heaters}$ ; and
- b) Any inconsistency between the claimed temperature/humidity map provided by the manufacturer and the measured values.

### G-9.9 Automatic Icemaker (See F-3 of Part 3)

For each automatic ice maker test included in the test, report include details on:

- a) Automatic ice maker test identifier;
- b) Nominal ambient temperature;
- c) Measured ambient temperature;
- d) Measured ambient relative humidity, in percent;

- e) Temperature control setting;
  - f) Average temperature of ice making bin after the ice making test is completed  $T_{ice}$ , in °C;
  - g) Steady state power consumption that occurs after all ice has been made during the valid energy test period (**B-3** or **B-4** of Part 3) as defined in **F-3.1.5** of Part 3,  $P_{after}$  (W);
  - h) The mass of water turned into ice during the test  $M_{ice-test}$  (kg);
  - j) Additional energy consumption by the refrigerating appliance to make the specific quantity of ice made during the test  $\Delta E_{ice-test}$  (Wh);
  - k) Additional energy consumption by the refrigerating appliance to make 1 kg of ice  $\Delta E_{kg-ice}$  (Wh);
  - m) Energy removed from the water load to make the specific quantity of ice made during the test  $\Delta E_{ice-enthalpy}$  (Wh);
  - n) Ice making efficiency for the specific ambient temperature and mass of ice made  $Efficiency_{ice}$ ;
  - p) Additional energy consumed by the refrigerating appliance to make Mice-making kg of ice per day at the specified ambient temperature  $\Delta E_{ice-making}$  (Wh/day);
  - q) Initial mass of the tank and residual water (kg);
  - r) Final mass of the tank and residual water (kg);
  - s) Mass of water load added to the tank (kg);
  - t) Nominal ambient temperature (°C);
  - u) Mass of ice made (kg);
  - v) Ambient temperature measured for the 6 hours prior to the start of the test (°C);
  - w) Duration of the ice making test (hours); and
  - y) Steady state power at the end of the test (W):
    - 1) Number of defrosts that occurred during the ice making test;
    - 2) Value of  $\Delta E_{df}$  used in calculations;
    - 3) Interpolated  $\Delta E_{ice-making}$  (if applicable) (Wh/day); and
    - 4) Annual energy consumption to make ice  $\Delta E_{ice-making-annual}$  (Wh/year).
- a) Measured ambient temperature (°C);
  - b) Measured ambient relative humidity (percent);
  - c) Volume of all unfrozen compartments (l);
  - d) Mass of water load added to unfrozen compartments (kg);
  - e) Number of PET bottles;
  - f) Location of PET bottles;
  - g) Volume of all frozen compartments (l);
  - h) Mass of water added to frozen compartments (kg);
  - j) Number of ice cube trays;
  - k) Location of ice cube trays;
  - m) Temperature control settings;
  - n) Average temperature of the temperature sensor at position TMP1 during the valid energy test period (*see B-3* or *B-4* of Part 3) after load processing (°C)(unfrozen compartment with PET bottles);
  - p) Average temperature of the temperature sensor at position TMP2 during the valid energy test period (*see B-3* or *B-4* of Part 3) after load processing (°C) (unfrozen compartment with PET bottles);
  - q) Average temperature of the temperature sensor at position TMP3 during the valid energy test period (*see B-3* or *B-4* of Part 3) after load processing (°C)(unfrozen compartment with PET bottles);
  - r) Average temperature of frozen compartment (°C) (frozen compartment with ice cube trays);
  - s) Steady state power consumption that occurs after the load has been fully processed during the valid energy test period (*see B-3* or *B-4* of Part 3) as defined in **G-4.4** of Part 3,  $P_{after}$  (W);
  - t) Energy removed from the water load in the unfrozen compartment during the test,  $E_{unfrozen-test}$  (Wh);
  - u) Energy removed from the water load in the frozen compartment during the test,  $E_{frozen-test}$  (Wh);
  - v) Total test input energy at a given ambient test room temperature  $E_{input-test}$  (Wh);
  - w) Additional energy consumption by the refrigerating appliance during the test to fully process the loaded added as specified in **G-3** of Part 3,  $E_{additional-test}$  (Wh); and
  - y) Measured load processing efficiency for the specified ambient temperature Efficiency load, ambient:
    - 1) Energy removed from the water load in the unfrozen compartment for nominal conditions,  $E_{unfrozen-nominal}$  (Wh);

A chart showing the selected test period is recommended.

#### **G-9.10 Load Processing Efficiency (See Annex G of Part 3)**

For each load processing efficiency test included in the test report include details on:

**IS 17550 (Part 1) : 2024**

- 2) Energy removed from the water load in the frozen compartment for nominal conditions,  $E_{\text{frozen-nominal}}$  (Wh);
  - 3) Nominal input energy at a given ambient test room temperature,  $E_{\text{input-nominal}}$  (Wh);
  - 4) Number of defrosts that occurred during the load processing test ( $z$ );
  - 5) Additional daily energy consumption of the refrigerating appliance,  $\Delta E_{\text{processing}}$  (Wh)
  - 6) Interpolated,  $\Delta E_{\text{processing}}$  (if applicable) (Wh); and
  - 7) Annual energy consumption to remove water load,  $\Delta E_{\text{processing-annual}}$  (Wh/year).
- A chart showing the selected test period is recommended.

**G-9.11 Checklist of Validity Criteria**

**G-9.11.1 Steady State: Case SS1**

<i>Sl No.</i>	<i>Requirement Checklist</i>
(1)	(2)
i)	Each block of test data shall contain an equal number of whole temperature control cycles.
ii)	Total test period $t_{\text{ABC}} \geq 6$ h; and Total test period $t_{\text{ABC}} \geq 12$ h where there are no temperature control cycles.
iii)	Spread of temperature $< 0.25$ K
iv)	Slope of temperature $< 0.025$ K/h
v)	Spread of power $\leq 0.01$ (for a total test period $t_{\text{ABC}}$ of 12 h or less; $\leq 0.01 + (t_{\text{ABC}} - 12)/1\ 200$ (for a total test period from $t_{\text{ABC}}$ 12 h to 36 h); and $\leq 0.03$ (for total test period $t_{\text{ABC}}$ of 36 h or more).
vi)	Spread of power where no temperature control cycles are present $< 1$ percent.
vii)	Slope of power $< 0.25$ percent/h
viii)	The two comparable test periods that start one and two temperature control cycles earlier than the period selected also meet all of the above criteria.
ix)	Where there are a number of possible test periods that meet the above criteria, the test period with the minimum spread of power from the available test data should be selected.

**G-9.11.2 Steady State: Case SS2**

<i>Sl No.</i>	<i>Requirement Checklist</i>
(1)	(2)
i)	Case SS2 usually applies to products where the steady state test period of interest is bounded by defrost and recovery periods.
ii)	Period $X$ ending at the start of a defrost and recovery period is selected.
iii)	Period $Y$ ending at the start of a next defrost and recovery period is selected.
iv)	Periods $X$ and $Y \geq 4$ whole temperature control cycles. Periods $X$ and $Y$ shall have the same number of temperature control cycles.
v)	Periods $X$ and $Y \geq 4$ h in length.
vi)	Period $X$ (in h)/period $Y$ (in h) = 0.8 to 1.25.
vii)	Spread of temperature $< 0.5$ K.
viii)	Spread of power $< 2$ percent or 1 W, whichever is the greater value.
ix)	The initial defrost and recovery period which is included in period SS2 shall qualify as a valid defrost and recovery period.



<i>Sl No.</i>	<i>Requirement Checklist</i>
x)	The value of $\Delta E_{df}$ for the initial defrost and recovery period which is included in period SS2 shall be determined.
xi)	Temperature control setting shall remain unchanged for all the test period used to determine the value for SS2, including the period used to determine the incremental defrost and recovery energy.
xii)	Where the initially selected period <i>X</i> and period <i>Y</i> do not comply with the acceptance criteria specified above, the minimum length of periods <i>X</i> and <i>Y</i> shall both be increased in steps of 1 temperature control cycle to see if there are any possible complying periods.
xiii)	Where the size of <i>X</i> and <i>Y</i> are increased, the first valid value using the sequence specified above shall be used.
xiv)	The length of <i>X</i> and <i>Y</i> < 50 percent of the defrost interval or 8 h, whichever is the longer.

### G-9.11.3 Defrost and Recovery: Case DF1

<i>Sl No.</i>	<i>Requirement Checklist</i>
(1)	(2)
i)	Period <i>D</i> is selected to be the minimum possible size.
ii)	Period <i>F</i> is selected to be the minimum possible size.
iii)	The nominal centre is defined as 2 h after initiation of the defrost heater on.
iv)	$\Delta t_{D1}$ and $\Delta t_{F1}$ shall be approximately the same.
v)	Periods <i>D</i> and <i>F</i> $\geq 3$ whole temperature control cycles. Periods <i>D</i> and <i>F</i> shall have the same number of temperature control cycles.
vi)	Periods <i>D</i> and <i>F</i> $\geq 3$ h in length. Period <i>D</i> shall finish not less than 3 h before the nominal centre.
vii)	Period <i>F</i> shall start not less than 3 h after the nominal centre.
viii)	Spread of temperature for periods <i>D</i> and <i>F</i> < 0.5 K.
ix)	Spread of power for periods <i>D</i> and <i>F</i> < 2 percent or 1 W, whichever is the greater value.
x)	Ratio of period <i>D</i> (in h)/period <i>F</i> (in h) = 0.8 to 1.25.
xi)	The start of any selected period <i>D</i> $\geq 5$ h after the initiation of the previous defrost heater on.
xii)	The end of any selected period <i>F</i> shall not be after the initiation of the subsequent defrost and recovery period.
xiii)	Where the initially selected period <i>D</i> and period <i>F</i> do not comply with the acceptance criteria specified above, the minimum length of period for periods <i>D</i> and <i>F</i> shall both be increased in steps of 1 temperature control cycle to see if there are any possible complying periods with $\Delta t_{D1}$ and $\Delta t_{F1}$ set to a minimum of 3 h.
xiv)	Where it is not possible to find complying periods <i>D</i> and <i>F</i> the minimum size of $\Delta t_{D1}$ and $\Delta t_{F1}$ shall be increased in 30 min steps and validity for varying sizes of <i>D</i> and <i>F</i> reassessed for each increase.
xv)	Where the size of <i>D</i> and <i>F</i> are increased or the length of $\Delta t_{D1}$ and $\Delta t_{F1}$ increased, the first valid value using the sequence specified above shall be used.
xvi)	Where no complying selections for periods <i>D</i> and <i>F</i> can be found using the above sequence, the distance from the start of the defrost and recovery period to the nominal centre of the defrost and recovery period may be adjusted from the default value of 2 h. The adjusted value shall not be less than 1 h and not more than 4 h and shall be a multiple of 30 min.
xvii)	Where any non-default parameters are used to select periods <i>D</i> and <i>F</i> , then this shall be noted.

**G-9.11.4 Defrost and Recovery: Case DF2 (if DF1 cannot be used)**

<i>Sl No.</i>	<i>Requirement Checklist</i>
(1)	(2)
i)	Case DF2 is only used where the refrigerating appliance does not reach steady state operation between defrost and recovery periods and establishment of incremental defrost and recovery energy using DF1 is not possible.
ii)	Periods D1, D2, F1, and F2 $\geq 2$ whole temperature control cycles. Periods D1, D2, F1, and F2 $\geq 2$ h in length.
iii)	Spread of temperature for the periods D1 and D2 $< 0.5$ K.
iv)	Spread of temperature for the periods F1 and F2 $< 0.5$ K.
v)	Spread of power for the periods D1 and D2 $< 2$ percent or 1 W, whichever is greater value.
vi)	Spread of power for the periods F1 and F2 $< 2$ percent or 1 W, whichever is greater value.

**G-9.11.5 Number of Valid Defrost and Recovery Periods**

<i>Sl No.</i>	<i>Requirement Checklist</i>
(1)	(2)
i)	Option 1: A valid value of $\Delta E_{df}$ shall be determined for each temperature control setting used for an energy determination on a single appliance. The defrost and recovery period selected for each temperature control setting shall be adjacent to the steady state period used for energy determination.
ii)	Option 2: the representative value for $\Delta E_{df}$ for the appliance shall be the average of at least 4 valid values. In this case, at least 50 percent of all values of $\Delta E_{df}$ shall have the coldest compartment at or below target temperature. A separate value for $\Delta E_{df}$ shall be determined for each ambient temperature.

**G-9.11.6 Tank-Type Automatic Icemakers**

<i>Sl No.</i>	<i>Requirement Checklist</i>
(1)	(2)
i)	The average temperature of all compartments that are used to store water and make/store ice shall be at or below the relevant target temperatures.
ii)	For verification tests, the temperature of ice making bin and the fresh food compartments (the compartment where the tank is stored) shall be within $\pm 1$ K of the relevant target temperature. Alternatively, the results of two ice making tests can be interpolated to the target temperature of the fresh food compartment while controls for other compartments are not adjusted.
iii)	The difference of the steady state power PSSM $\leq 5$ percent or 2 W, whichever is greater value.
iv)	Where the initial validity is determined using a defrost under <b>C-3</b> of Part 3, because the validity in accordance with <b>B-3</b> of Part 3 or <b>B-4</b> of Part 3 cannot be established, the initial steady state power PSSM above is taken as the average power of periods D and F.
v)	For a refrigerating appliance with one or more defrost systems (with its own defrost control cycle), where the above conditions are not met, the appliance shall be operated until the next defrost and recovery period has been completed and a new steady state condition established and assessed against this criterion.
vi)	If this validity criterion cannot be met after a subsequent defrost, the test shall be repeated. The result of the repeated test is used to determine the energy consumption for the ice making test. After steady state operation is established, the ice made from the previous test is removed and weighed. The door opening time should not exceed 20 s. The ice making test is started again, commencing with the temperature control cycle after the temperature control cycle where the ice was taken out. For refrigerating appliances with one or more defrost control cycles, any defrost and recovery period that occurs during the automatic ice making test shall be allowed to continue to completion.

**G-9.11.7** Load Processing Efficiency

<i>Sl No.</i>	<i>Requirement Checklist</i>
(1)	(2)
i)	The average temperature of all compartments that are used to process test load shall be at or below the relevant target temperatures during the steady state operation prior to load processing.
ii)	For verification tests, the temperatures of all compartments that are used to process the test load shall be within $\pm 1$ K of the relevant target temperature during the steady state operation prior to load processing. Alternatively, the results of two load processing efficiency tests can be interpolated to the value at the compartment target temperature of the coldest compartment, but one of the test points shall have all compartments that are used to process test load at or below target temperatures.
iii)	Wherever possible, 3 shelves shall be used to hold the processing load in an unfrozen compartment and shall be configured so that: <ul style="list-style-type: none"> <li>a) Sensor <math>T_3</math> is above shelf 3 and below shelf 2;</li> <li>b) Sensor <math>T_2</math> is above shelf 2 and below shelf 1; and</li> <li>c) Sensor <math>T_1</math> is above shelf 1.</li> </ul>
iv)	The difference of the steady state power $PSSM \leq 5$ percent or 2 W, whichever is greater value; and the difference of steady state temperature shall be $\leq 1$ K.
v)	If the validity in accordance with <b>B-3</b> of Part 3 or <b>B-4</b> of Part 3 cannot be established, the initial steady state power PSSM and steady state temperature above is taken as the average power of period D and period F.
vi)	In the case of a refrigerating appliance with one or more defrost systems, where the above conditions are not met, the appliance shall be operated until the next defrost and recovery period has been completed and a new steady state condition established and assessed against these criteria.
vii)	If both of these validity criteria cannot be met after a subsequent defrost, the test shall be repeated by replacing the existing load with new load under the same control conditions. As set out above, placing an initial processing load into the refrigerating appliance and replacing this with a new processing load is optional for all load processing tests.

## ANNEX H

(Clauses [3.1.6](#) and [3.3.14](#))

## WINE STORAGE APPLIANCE

**H-1 SCOPE**

The purpose of this Annex is to determine terms, definitions, and performance of wine storage appliances.

**H-2 TERMS, DEFINITIONS, AND SYMBOLS**

For the purposes of this Annex, the following terms, definitions, and symbols apply.

**H-2.1 Wine Storage Compartment Temperature**

$T_{wma}$  is the arithmetic average temperature of the wine storage temperatures  $T_{w1m}$ ,  $T_{w2m}$ ,  $T_{w3m}$ .

**H-2.2 Ambient Air Exchange Device**

Device which allows the exchange of the air in a refrigerating compartment with ambient air. This is either fixed by the manufacturer, automatically controlled, or set manually by the user as per the instructions.

NOTE — A hole for defrost water drainage is not to be considered to be an air exchange device.

**H-3 REQUIREMENTS****H-3.1 Required Temperature Range**

The appliance shall have a continuous storage temperature, either pre-set or set manually according to the instructions, in the range from  $T_{wma} = + 5 \text{ }^{\circ}\text{C}$  to  $+ 20 \text{ }^{\circ}\text{C}$ . Each compartment shall provide  $T_{wma} \leq + 12 \text{ }^{\circ}\text{C}$ .

NOTE — The range  $+ 5 \text{ }^{\circ}\text{C}$  to  $+ 20 \text{ }^{\circ}\text{C}$  indicates the maximum allowed range, not the target values.

**H-3.2 Maximum Temperature Fluctuation**

Storage temperature(s) shall vary over time by less than 0.5 K at each declared ambient temperature specified by the climate class for household refrigerating appliances (*see* [4](#)). The definition of the temperature variation is given in [H-7](#).

**H-3.3 Vibration**

The appliance shall be constructed to reduce the transmission of vibration to the compartment, whether from the refrigerator compressor or from any external source.

**H-4 GENERAL TEST CONDITIONS****H-4.1 General**

See [B-3](#) of this standard (Part 1) applies unless otherwise

specified for wine storage appliances.

**H-4.2 Low Ambient Temperature**

For tests at ambient temperatures close to or below the average storage temperature for the specified compartment, instructions on possible warmest temperature setting when applicable shall be considered.

**H-4.3 Interior Parts**

If the position of shelves is adjustable these shall be spread equally in the cabinet. Shelves, baskets, and containers shall be in position as defined in the instructions.

**H-5 DETERMINATION OF VOLUMES****H-5.1 Depth**

For wine storage appliances, where a back mounted evaporator is covered by a fixed cover (for example, its protection) the depth of the evaporator space shall be taken as the mean horizontal distance to the foremost part of the protection cover.

**H-5.2 Evaluation of Bottle Capacity for Wine Storage Compartments**

For the evaluation of the rated capacity of bottles 0.75 litre bottles or equivalent substitution with dimension as specified in [Fig. 23](#) shall be used.

To check the deformation of shelves etc. under normal usage conditions, bottles are to contain water to provide a total weight of each bottle of  $1\ 200\ \text{g} \pm 50\ \text{g}$ .

Removable parts which are stated by the manufacturer as necessary for the proper thermal and mechanical functioning of the wine storage compartment have to be placed in their intended positions as per the instructions. Bottles shall be stacked in each space intended to carry bottles in normal usage as follows:

- a) Clearance to wall/back/door shall be as per the instructions;
- b) In the absence of instructions, to ensure proper cooling, the rear end of shelves, and 5 mm clearance to the door are considered as limits;
- c) Bottles placed in door shelves may touch the door liner;
- d) If the evaporator is covered by fixed means for protection, bottles can be stacked touching the

- protection;
- e) Bottles can be placed reverse and interleaved;
  - f) Bottles can touch side walls if nothing else is stated by the manufacturer;
  - g) Bottles can be placed horizontally or vertically or inclined if fixed means are provided for inclined positions; and

- h) Movable parts like telescopic shelves have to be kept movable and accessible under loading conditions.

A sketch of the bottle loading plan showing the location of bottles for evaluation of the bottle capacity for wine storage compartments shall be included in any test report.

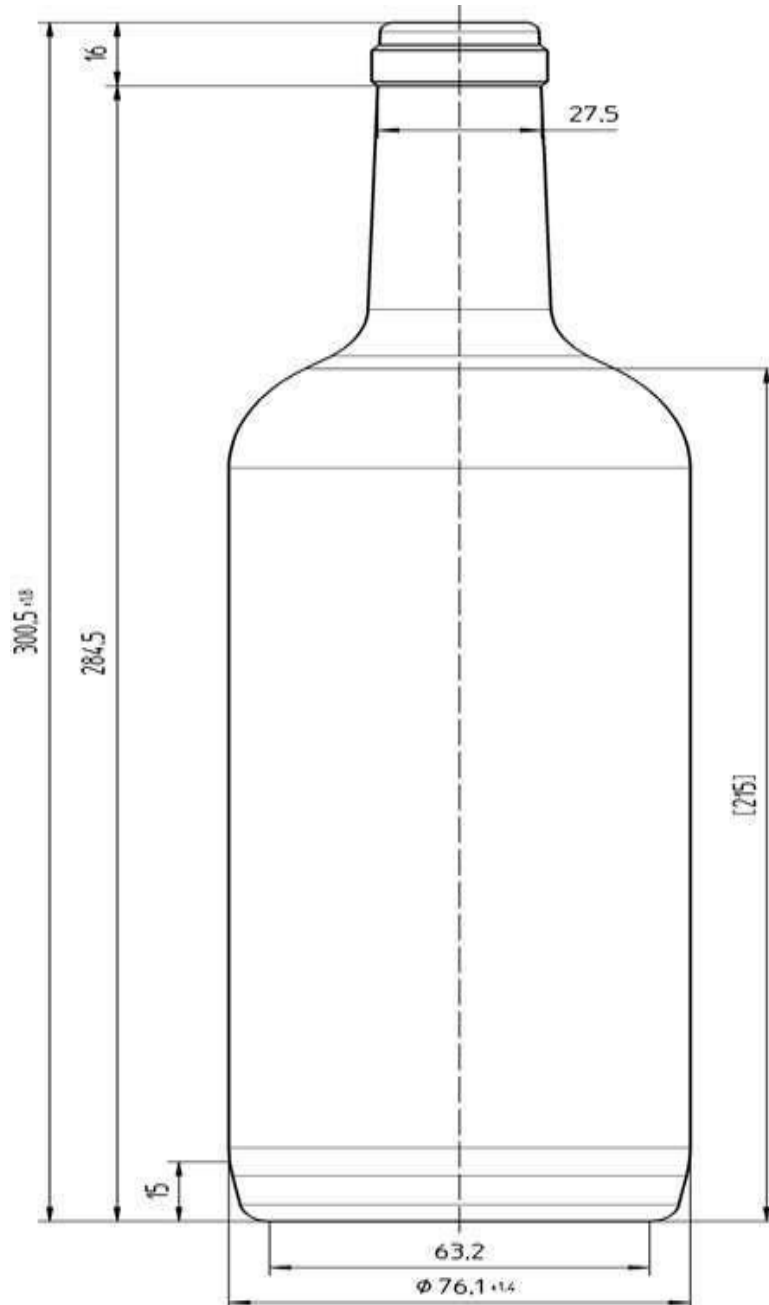

All dimensions in millimetres.

FIG. 22 STANDARD BOTTLE FOR EVALUATION OF BOTTLE CAPACITY

**H-6 MEASUREMENT OF STORAGE TEMPERATURE**

The temperatures  $T_{w1m}$ ,  $T_{w2m}$ , and  $T_{w3m}$  shall be measured in M-packages supported or suspended in order to have their geometrical centre at the temperature-sensing points and so that their largest surface is horizontal. The M-packages may be supported, for example, by use of a block of expanded polystyrene (EPS) of the same base dimensions as the M-package. M-packages shall have no direct contact with any other surface.

For determining the storage temperature, the temperature-sensing points shall be located at  $TMP_{w1}$ ,  $TMP_{w2}$ ,  $TMP_{w3}$  as shown in Fig. 24, halfway between the rear internal wall of the appliance and the internal wall of the closed door. Walls defined as being considered for the calculation of storage volume.

The M-packages shall be separated from any heat-conducting surface by at least 25 mm of air space. The instantaneous temperatures of the M-packages  $T_{w1}$ ,  $T_{w2}$ , and  $T_{w3}$  shall be recorded.

The temperatures  $T_{w1m}$ ,  $T_{w2m}$ , and  $T_{w3m}$  at the temperature-sensing points shall be the integrated time

averages of  $T_{w1}$ ,  $T_{w2}$ , and  $T_{w3}$  during a test period with an integral step of 60 s or less.

The storage temperature  $T_{wma}$  is the arithmetical average of the mean temperatures  $T_{w1m}$ ,  $T_{w2m}$ , and  $T_{w3m}$ .

If internal components do not allow the temperatures  $T_{w1}$ ,  $T_{w2}$ , and  $T_{w3}$  to be read at the points specified, readings shall be taken in positions such that the geometrical centre of the M-package is no more than 25 mm from the point specified. If the interior arrangement of the wine storage compartment does not conform to those shown in Fig. 23, the temperatures  $T_{w1}$ ,  $T_{w2}$ , and  $T_{w3}$  shall be read in positions determined by analogy with the positions indicated.

If there is an ambient air exchange device and this can be influenced by the user the device shall be set to operate for normal usage as per the manufacturer instructions.

Storage temperatures shall be tested at the lowest and highest ambient temperatures for the claimed climate classes. Each wine storage compartment shall be measured at  $T \leq 12\text{ }^\circ\text{C}$ .

The temperatures shall be recorded.

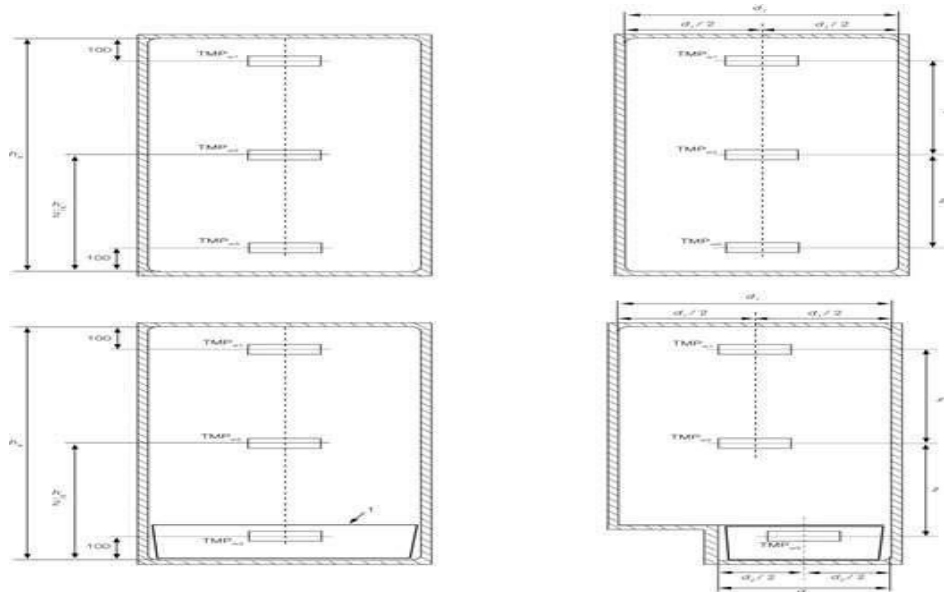

**NOTES**

- 1 For wine storage appliances closed with one door but split by a fixed or adjustable divider in separate compartments with independent temperature control the above arrangement shall apply for each compartment.
- 2 If  $z < 100\text{ mm}$   $TMP_{w2}$  shall not be used.
- 3 If  $hw < 300\text{ mm}$   $TMP_{w2}$  shall be used.

**Key**

- 1 Shelf above a container placed at lowest possible position; and
- 2  $D_1$  resp  $D_2$  = Distance between reference lines as used for net volume determination.

FIG. 23 TEMPERATURE MEASUREMENT POINTS (PACKAGES)

## H-7 DETERMINING TEMPERATURE FLUCTUATION

Determining of the temperature fluctuation will be performed at the temperature  $T_{wma} = 12\text{ °C}$  or the nearest colder temperature at an ambient temperature of  $25\text{ °C}$  and at the lowest and highest ambient temperature for the climate class claimed. The test will be performed in condition as specified in [H-6](#).

The temperature fluctuation is evaluated for each measuring point  $TMP_{wi}$ . The instantaneous temperatures of the M-packages  $T_{w1}$ ,  $T_{w2}$ , and  $T_{w3}$  shall be recorded.

An amplitude is the difference between the warmest and coldest instantaneous temperature between two successive stops of the refrigerating system. If no successive stops of the refrigerating system can be identified a continuous period of 4 h will be considered.

The average of all temperature amplitudes at each measurement point  $TMP_{wi}$  during the whole test period shall stay within 0.5 K.

## H-8 FINAL TEST REPORT

Any final test report for wine storage appliances shall include the test results of the following:

- a) Energy consumption (*see* **5** of Part 3 of this standard);
- b) Temperature fluctuation (*see* **B-5.1** of Part 2 of this standard);
- c) Bottle capacity of the compartments (*see* [H-5.2](#) of this standard); and
- d) A sketch of the bottle loading plan showing the location of bottles for evaluation of the bottlecapacity.

## H-9 MARKING AND INSTRUCTIONS

### H-9.1 Technical and Commercial Product Information

The following information shall be marked on technical and product information of wine storage appliances: ‘This appliance is intended to be used exclusively for the storage of wine’.

This shall not apply to household refrigerating appliances that are not specifically designed for wine storage but may nevertheless be used for this purpose or to household refrigerating appliances that have a wine storage compartment combined with any other compartment type.

### H-9.2 Instructions

The following information shall be marked on Instructions provided with wine storage appliances: ‘This appliance is intended to be used exclusively for the storage of wine’.

This shall not apply to household refrigerating appliances that are not specifically designed for wine storage but may nevertheless be used for this purpose or to household refrigerating appliances that have a wine storage compartment combined with any other compartment type.

For compartments providing a temperature setting close to or higher than the declared lowest climate class temperature, instructions shall be provided on the warmest possible temperature setting at low ambient temperatures.



ANNEX J

(Clauses [1.6](#) and [5.5](#))

**CRITERIA FOR ECO-LABEL FOR REFRIGERATORS**

**J-1** The refrigerators shall conform to the requirements for quality, safety, and performance prescribed in the standard.

**J-2** The manufacturer shall produce the consent clearance as per the provisions of *Water (Prevention and Control of Pollution) Act, 1974*, *Water (Prevention and Control of Pollution) Cess Act, 1977*, and *Air (Prevention and Control of Pollution) Act, 1981* along with the authorization, if required under the *Environment (Protection) Act, 1986* to BIS while applying for ECO-Mark.

**J-3 NOISE LEVEL**

For ECO-Mark the refrigerators shall conform to the noise levels as notified under the *Environment (Protection) Act, 1986* from time to time.

**J-4 INSTRUCTIONS**

The refrigerators shall be sold along with instructions for proper use so as to maximize product performance, minimize wastage, and method of safe disposal of used product.

**J-5 ENERGY CONSUMPTION**

The power consumption shall be at least 5 percent less than those specified in the standard.

**J-6 ENERGY EFFICIENCY**

The product shall have at least 96 percent energy efficiency.

**J-7 PACKING**

The refrigerators shall be packed in such packages, which are made of recyclable or biodegradable materials.

**J-8 REFRIGERANTS**

The refrigerants and foam blowing agents shall not contain any ozone depleting substances (ODS) relevant to the refrigeration industry as identified under montreal protocol.

## COMMITTEE COMPOSITION

Refrigeration and Air Conditioning Sectional Committee, MED 03

<i>Organization</i>	<i>Representative (s)</i>
Indian Institute of Technology Roorkee, Roorkee	PROF RAVI KUMAR ( <i>Chairperson</i> )
Blue Star Limited, Mumbai	SHRI JITENDRA BHAMBURE SHRI SUNIL KUMAR JAIN ( <i>Alternate I</i> ) MS SNEHA HARSORA ( <i>Alternate II</i> )
BSH Household Appliances Manufacturing Private Limited, Chennai	SHRI LOGANATHAN VIJAY KUMAR SHRI BALASUBRAMANIAN ANAND ( <i>Alternate</i> )
Bureau of Energy Efficiency, New Delhi	MS PRAVATANALINI SAMAL MS DEEPSHIKHA WADHWA ( <i>Alternate I</i> ) SHRI KAMRAN SHAIK ( <i>Alternate II</i> ) SHRI DHEERAJ PANDEY ( <i>Alternate III</i> )
Carrier Air Conditioning and Refrigeration Limited, Gurugram	SHRI BIMAL TANDON SHRI MANMOHAN KULASHRI ( <i>Alternate I</i> ) SHRI JATINDER SHARMA ( <i>Alternate II</i> )
Central Power Research Institute, Bengaluru	DR P. CHANDRA SEKHAR SHRI GUJJALA B. BALARAJA ( <i>Alternate</i> )
CEPT University, Ahmedabad	SHRI YASH SHUKLA
Copeland India Private Limited, Pune	SHRI S. CHETHAN THOLPADY SHRI S. P. DESHPANDE ( <i>Alternate</i> )
Daikin Air Conditioning India Private Limited, Gurugram	SHRI GAURAV MEHTANI
Danfoss Industries Private Limited, Gurugram	SHRI MADHUR SEHGAL SHRI K. L. NAGAHARI ( <i>Alternate I</i> ) SHRI M. N. S. V. KIRAN KUMAR ( <i>Alternate II</i> )
Directorate General of Quality Assurance, Ministry of Defence, New Delhi	LT COL DEEPAK SHARMA SHRI S. S. NIKAM ( <i>Alternate</i> )
Electrical Research and Development Association, Vadodara	SHRI GUATAM BRAHMBHATT SHRI RAKESH PATEL SINGH ( <i>Alternate</i> )
Frigoglass India Private Limited, Gurugram	SHRI MAHESH KUMAR MAWAI SHRI MANDEEP SINGH ( <i>Alternate I</i> ) MS RITU CHOUHAN ( <i>Alternate II</i> )
Godrej & Boyce Manufacturing Company Limited, Mumbai	SHRI BURZIN WADIA SHRI JASVIR SINGH ( <i>Alternate I</i> ) SHRI NARENDRA SHEDGE ( <i>Alternate II</i> )
Honeywell International India Private Limited, Gurugram	SHRI AADITYA PEGALLAPATI SHRI AVINASH KUMAR ( <i>Alternate</i> )
Indian Institute of Chemical Engineering, Kolkata	DR D. SATHIYAMOORTHY DR SUDIP K. DAS ( <i>Alternate</i> )
Indian Institute of Technology Madras, Chennai	DR G. VENKATARATHNAM
Indian Society of Heating, Refrigerating and Air Conditioning Engineers, New Delhi	DR JYOTIRMAY MATHUR SHRI ASHISH RAKHEJA ( <i>Alternate I</i> ) SHRI V. MANJUNATH ( <i>Alternate II</i> )
Ingersoll Rand India Limited, Bengaluru	SHRI M. VENKANNA SHRI J. GURUSAMY ( <i>Alternate</i> )

**IS 17550 (Part 1) : 2024**

<i>Organization</i>	<i>Representative (s)</i>
International Copper Association India, Mumbai	SHRI MAYUR KARMAKAR SHRI SHANKAR SAPALIGA ( <i>Alternate</i> )
Intertek India Private Limited, Gurugram	SHRI C. M. PATHAK
Johnson Controls-Hitachi Air Conditioning India Limited, Mehsana	SHRI RAHUL RAMTEKKAR MS HEENA RAMSINGHANI ( <i>Alternate</i> )
LG Electronics India Private Limited, New Delhi	SHRI ADITYA ANIL
Refrigeration and Air Conditioning Manufacturers Association, New Delhi	SHRI KANWALJEET JAWA SHRI HARSH VARDHAN PANT ( <i>Alternate</i> )
Samsung India Electronics Private Limited, New Delhi	SHRI KALICHARAN SAHU SHRI AMIT KUMAR JHA ( <i>Alternate</i> )
Sierra Aircon Private Limited, Gurugram	SHRI D. K. MUDGAL SHRI S. DHIMAN ( <i>Alternate</i> )
The Chemours India Private Limited, Gurugram	SHRI VIKAS MEHTA SHRI NISHIT SHAH ( <i>Alternate</i> )
UL India Private Limited, Bengaluru	SHRI V. MANJUNATH SHRI SATISH KUMAR ( <i>Alternate</i> )
Voltas Limited, Mumbai	SHRI SRINIVASAN MOTURI SHRI A. D. KUMBHAR ( <i>Alternate</i> )
Voluntary Organisation in Interest of Consumer Education (VOICE), New Delhi	SHRI B. K. MUKHOPADHYAY SHRI H. S. WADHWA ( <i>Alternate</i> )
In Personal Capacity ( <i>H. No. 03, Savita Vihar, Delhi</i> )	SHRI J. K. AGRAWAL
In Personal Capacity ( <i>506/2, Kirti Apartments, Mayur Vihar, Phase-1 Extension, Delhi</i> )	SHRI P. K. MUKHERJEE
BIS Directorate General	SHRI K. VENKATESWARA RAO, SCIENTIST 'F'/SENIOR DIRECTOR AND HEAD (MECHANICAL ENGINEERING) [REPRESENTING DIRECTOR GENERAL ( <i>Ex-officio</i> )]

*Member Secretary*  
MS NEHA THAKUR  
SCIENTIST 'C'/DEPUTY DIRECTOR  
(MECHANICAL ENGINEERING), BIS

(Continued from second cover)

- 7) Ice making test (if applicable); and
- 8) Test for absence of odour and taste;
- c) Safety requirements;
- d) Packing;
- e) Designation;
- f) Instructions for use and maintenance;
- g) Schedule of test; and
- h) Criteria for ECO-Mark (optional requirements).

A scheme of labelling environmentally friendly products with an ECO logo known as ECO-Mark has been introduced at the instance of the Ministry of Environment, Forest and Climate Change (MoEFCC), Government of India. The Ministry of Environment, Forest and Climate Change, Government of India, issued a notification dated 17 May 1996 [GSR 2 14(E)] for ECO labelling of refrigerators. These ECO labelling criteria relevant to refrigerators have been incorporated in this standard.

This standard contributes to the Sustainable Development Goal 9 — ‘Industry, Innovation and Infrastructure: Build resilient infrastructure’, promote inclusive and sustainable industrialization and foster innovation’.

The composition of the Committee responsible for the formulation of this standard is given in [Annex K](#).

For the purpose of deciding whether a particular requirement of this standard is complied with, the final value, observed or calculated, expressing the result of a test or analysis, shall be rounded off in accordance with IS 2 : 2022 ‘Rules for rounding off numerical values (*second revision*)’. The number of significant places retained in the rounded off value should be the same as that of the specified value in this standard.

## Bureau of Indian Standards

BIS is a statutory institution established under the *Bureau of Indian Standards Act, 2016* to promote harmonious development of the activities of standardization, marking and quality certification of goods and attending to connected matters in the country.

### Copyright

BIS has the copyright of all its publications. No part of these publications may be reproduced in any form without the prior permission in writing of BIS. This does not preclude the free use, in the course of implementing the standard, of necessary details, such as symbols and sizes, type or grade designations. Enquiries relating to copyright be addressed to the Head (Publication & Sales), BIS.

### Review of Indian Standards

Amendments are issued to standards as the need arises on the basis of comments. Standards are also reviewed periodically; a standard along with amendments is reaffirmed when such review indicates that no changes are needed; if the review indicates that changes are needed, it is taken up for revision. Users of Indian Standards should ascertain that they are in possession of the latest amendments or edition by referring to the website-[www.bis.gov.in](http://www.bis.gov.in) or [www.standardsbis.in](http://www.standardsbis.in).

This Indian Standard has been developed from Doc No.: MED 03 (22235).

### Amendments Issued Since Publication

Amend No.	Date of Issue	Text Affected

## BUREAU OF INDIAN STANDARDS

### Headquarters:

Manak Bhavan, 9 Bahadur Shah Zafar Marg, New Delhi 110002

Telephones: 2323 0131, 2323 3375, 2323 9402

Website: [www.bis.gov.in](http://www.bis.gov.in)

### Regional Offices:

Central : 601/A, Konnectus Tower -1, 6<sup>th</sup> Floor,  
DMRC Building, Bhavbhuti Marg, New  
Delhi 110002

Telephones

{ 2323 7617

Eastern : 8<sup>th</sup> Floor, Plot No 7/7 & 7/8, CP Block, Sector V,  
Salt Lake, Kolkata, West Bengal 700091

{ 2367 0012  
{ 2320 9474

Northern : Plot No. 4-A, Sector 27-B, Madhya Marg,  
Chandigarh 160019

{ 265 9930

Southern : C.I.T. Campus, IV Cross Road, Taramani, Chennai 600113

{ 2254 1442  
{ 2254 1216

Western : 5<sup>th</sup> Floor/MTNL CETTM, Technology Street, Hiranandani Gardens, Powai  
Mumbai 400076

2570 0030  
2570 2715

**Branches :** AHMEDABAD, BENGALURU, BHOPAL, BHUBANESHWAR, CHANDIGARH, CHENNAI, COIMBATORE, DEHRADUN, DELHI, FARIDABAD, GHAZIABAD, GUWAHATI, HARYANA (CHANDIGARH), HUBLI, HYDERABAD, JAIPUR, JAMMU, JAMSHEDPUR, KOCHI, KOLKATA, LUCKNOW, MADURAI, MUMBAI, NAGPUR, NOIDA, PARWANOO, PATNA, PUNE, RAIPUR, RAJKOT, SURAT, VIJAYAWADA.