

विद्युत नियुक्ति के लिए केबल ट्रकिंग  
प्रणालियाँ और केबल वाहिनी प्रणालियाँ  
भाग 1 सामान्य अपेक्षाएँ  
(पहला पुनरीक्षण)

**Cable Trunking Systems and Cable  
Ducting Systems for Electrical  
Installations**

**Part 1 General Requirements**  
( *First Revision* )

ICS 29.060.01; 29.120.10

© BIS 2023

© IEC 2017



भारतीय मानक ब्यूरो  
BUREAU OF INDIAN STANDARDS  
मानक भवन, 9 बहादुर शाह ज़फर मार्ग, नई दिल्ली - 110002  
MANAK BHAVAN, 9 BAHADUR SHAH ZAFAR MARG  
NEW DELHI - 110002  
[www.bis.gov.in](http://www.bis.gov.in) [www.standardsbis.in](http://www.standardsbis.in)

## NATIONAL FOREWORD

This Indian Standard (Part 1) (First Revision) which is identical with IEC 61084-1: 2017 'Cable trunking systems and cable ducting systems for electrical installations — Part 1: General requirements' issued by the International Electrotechnical Commission (IEC) was adopted by the Bureau of Indian Standards on the recommendation of the Electrical Wiring Accessories Sectional Committee and approval of the Electrotechnical Division Council.

This standard was first published in 2001. The first revision of this standard has been undertaken to align it with latest version of IEC 61084-1 to make pace with the latest development that have taken place at international level.

The text of the IEC standard has been approved as suitable for publication as an Indian Standard without deviations. Certain conventions are, however, not identical to those used in Indian Standards. Attention is particularly drawn to the following:

- a) Wherever the words 'International Standard' appears referring to this standard, they should be read as 'Indian Standard'; and
- b) Comma (,) has been used as a decimal marker, while in Indian Standards the current practice is to use a point (.) as the decimal marker.

In this adopted standard, reference appears to International Standards for which Indian Standards also exists. The corresponding Indian Standards, which are to be substituted, are listed below along with their degree of equivalence for the editions indicated:

<i>International Standard</i>	<i>Corresponding Indian Standard</i>	<i>Degree of Equivalence</i>
IEC 60423 : 2007 Conduit systems for cable management — Outside diameters of conduits for electrical installations and threads for conduits and fittings	IS 14763 : 2022/IEC 60423 : 2007 Conduit systems for cable management — Outside diameters of conduits for electrical installations and threads for conduits and fittings ( <i>first revision</i> )	Identical
IEC 60529 : 1989 Degrees of protection provided by enclosures (IP Code) IEC 60529 : 1989/AMD1 : 1999 IEC 60529 : 1989/AMD2 : 2013	IS/IEC 60529 : 2001 Degrees of protection provided by enclosures (IP Code)	Identical
IEC 60695-2-11 : 2014 Fire hazard testing — Part 2-11: Glowing/hot wire based test methods — Glow-wire flammability test method for end-products (GWEPT)	IS/IEC 60695-2-11 : 2014 Fire hazard testing: Part 2-11 Glowing/hot-wire based test methods — Glow-wire flammability test method for end-products (GWEPT)	Identical
IEC 61032 : 1997 Protection of persons and equipment by enclosures — Probes for verification	IS 1401 : 2008/IEC 61032 : 1997 Protection of persons and equipment by enclosures — Probes for verification ( <i>second revision</i> )	Identical
ISO 2768-1 : 1989 General tolerances — Part 1: Tolerances for linear and angular dimensions without individual tolerance indications	IS 2102 (Part 1) : 1993/ISO 2768-1 : 1989 General tolerances: Part 1 Tolerances for linear and angular dimensions without individual tolerance indications ( <i>third revision</i> )	Identical

(Continued on third cover)

## CONTENTS

1	Scope .....	1
2	Normative references .....	1
3	Terms and definitions .....	1
4	General requirements .....	6
5	General conditions for tests .....	6
6	Classification .....	7
6.1	According to material .....	7
6.2	According to resistance to impact for installation and application .....	7
6.2.1	CTS/CDS for impact 0,5 J .....	7
6.2.2	CTS/CDS for impact 0,7 J .....	7
6.2.3	CTS/CDS for impact 1 J .....	7
6.2.4	CTS/CDS for impact 2 J .....	7
6.2.5	CTS/CDS for impact 5 J .....	7
6.2.6	CTS/CDS for impact 10 J .....	7
6.2.7	CTS/CDS for impact 20 J .....	7
6.3	According to temperatures as given in Table 1, Table 2 and Table 3 below .....	7
6.4	According to resistance to flame propagation .....	8
6.4.1	Flame propagating CTS/CDS .....	8
6.4.2	Non-flame propagating CTS/CDS .....	8
6.5	According to electrical continuity characteristic .....	8
6.5.1	CTS/CDS with electrical continuity characteristic .....	8
6.5.2	CTS/CDS without electrical continuity characteristic .....	8
6.6	According to electrical insulating characteristic .....	8
6.6.1	CTS/CDS without electrical insulating characteristic .....	8
6.6.2	CTS/CDS with electrical insulating characteristic .....	8
6.7	According to degrees of protection provided by enclosure according to IEC 60529:1989 .....	8
6.7.1	According to protection against ingress of solid foreign objects .....	8
6.7.2	According to protection against ingress of water .....	8
6.7.3	According to protection against access to hazardous parts .....	8
6.8	According to protection against corrosive or polluting substances .....	8
6.9	According to the system access cover retention .....	8
6.9.1	CTS/CDS access cover, which can be opened without a tool .....	8
6.9.2	CTS/CDS access cover, which can only be opened with a tool .....	8
7	Marking and documentation .....	8
8	Dimensions .....	11
9	Construction .....	11
9.1	Sharp edges .....	11
9.2	Apparatus mounting .....	11
9.3	Means for protective separation and/or retention .....	11
9.4	Mechanical connections .....	12
9.5	Accessible conductive parts .....	13
9.6	Equipotential bonding .....	14
9.7	Access to live parts .....	14
9.8	Inlet openings .....	15

9.9	Membranes .....	15
9.10	Cable restrainer .....	15
9.11	Cable anchorage.....	16
10	Mechanical properties.....	17
10.1	Mechanical strength.....	17
10.2	Cable support test.....	17
10.3	Impact test.....	17
10.3.1	Impact test for storage and transport .....	17
10.3.2	Impact test for installation and application .....	18
10.4	Linear deflection test.....	18
10.5	External load test.....	18
10.5.1	Fixing test for apparatus mounting of socket outlets .....	18
10.5.2	Fixing test for apparatus mounting other than socket outlets.....	19
10.6	System access cover retention.....	19
11	Electrical properties.....	20
11.1	Electrical continuity.....	20
11.1.1	General .....	20
11.1.2	Preparation and conditioning .....	20
11.1.3	Electrical impedance tests .....	20
11.2	Electrical insulation.....	22
11.2.1	Solid insulation .....	22
11.2.2	Conditioning and preparation .....	22
11.2.3	Insulation resistance test.....	23
11.2.4	Dielectric strength test.....	23
12	Thermal properties .....	23
12.1	Resistance to heat .....	23
12.1.1	General .....	23
12.1.2	Test for non-metallic or composite system components necessary to retain current-carrying parts in position.....	23
12.1.3	Test for non-metallic or composite system components not necessary to retain current-carrying parts in position.....	24
13	Fire hazard.....	24
13.1	Reaction to fire .....	24
13.1.1	Initiation of fire .....	24
13.1.2	Contribution to fire .....	25
13.1.3	Spread of fire.....	25
13.1.4	Additional reaction to fire characteristics .....	26
13.2	Resistance to fire.....	26
14	External influences .....	26
14.1	Degree of protection provided by enclosure .....	26
14.1.1	General .....	26
14.1.2	Protection against ingress of solid foreign objects .....	26
14.1.3	Protection against ingress of water .....	27
14.1.4	Protection against access to hazardous parts .....	27
14.2	Protection against corrosive or polluting substances .....	27
15	Electromagnetic compatibility .....	27
Annex A (informative) Types of cable trunking systems (CTS) and cable ducting systems (CDS).....		36
Annex B (normative) CTS/CDS IK code .....		38

Bibliography.....	39
Figure 1 – Types and application of trunking systems (CTS) and ducting systems (CDS) .....	28
Figure 2 – Example of impact test apparatus .....	29
Figure 3 – Arrangement for test for resistance to flame propagation .....	30
Figure 4 – Enclosure for test for resistance to flame propagation .....	31
Figure 5 – Ball pressure test apparatus.....	31
Figure 6 – Electrical impedance tests arrangement .....	33
Figure 7 – Examples of membranes and grommets .....	33
Figure 8 – Typical apparatus for testing the resistance of cable anchorage to pull force .....	34
Figure 9 – Typical apparatus for testing the resistance of cable anchorage to twist force .....	35
Figure 10 – Piston for durability of marking test .....	35
Table 1 – Minimum storage and transport temperature .....	7
Table 2 – Minimum installation and application temperature .....	7
Table 3 – Maximum application temperature .....	7
Table 4 – Torque values for the test of screwed connections .....	13
Table 5 – Forces and torques to be applied to cable anchorage.....	17
Table 6 – Impact test values .....	18
Table A.1 – Types of CTS and CDS for wall and ceiling installation .....	36
Table A.2 – Types of CTS and CDS for floor installation .....	36
Table A.3 – Types of CTS and CDS for installation between two opposite surfaces .....	37



*Indian Standard*

# CABLE TRUNKING SYSTEMS AND CABLE DUCTING SYSTEMS FOR ELECTRICAL INSTALLATIONS

## PART 1 GENERAL REQUIREMENTS

### 1 Scope

This part of the IEC 61084 series specifies requirements and tests for cable trunking systems (CTS) and cable ducting systems (CDS) intended for the accommodation, and where necessary for the electrically protective separation, of insulated conductors, cables and possibly other electrical equipment in electrical and/or communication systems installations. The maximum voltage of these installations is 1 000 V AC and 1 500 V DC.

This document does not apply to conduit systems, cable tray systems, cable ladder systems, power track systems or equipment covered by other standards.

NOTE This part of the IEC 61084 series is not intended to be used by itself.

### 2 Normative references

The following documents are referred to in the text in such a way that some or all of their content constitutes requirements of this document. For dated references, only the edition cited applies. For undated references, the latest edition of the referenced document (including any amendments) applies.

IEC 60417, *Graphical symbols for use on equipment*

IEC 60423:2007, *Conduit systems for cable management – Outside diameters of conduits for electrical installations and threads for conduits and fittings*

IEC 60529:1989, *Degrees of protection provided by enclosures (IP Code)*

IEC 60529:1989/AMD1:1999

IEC 60529:1989/AMD2:2013

IEC 60695-2-11:2014, *Fire hazard testing – Part 2-11: Glowing/hot-wire based test methods – Glow-wire flammability test method for end-products (GWEPT)*

IEC 60695-11-2:2013, *Fire hazard testing – Part 11-2: Test flames – 1 kW pre-mixed flame – Apparatus, confirmatory test arrangement and guidance*

IEC 61032:1997, *Protection of persons and equipment by enclosures – Probes for verification*

ISO 2768-1:1989, *General tolerances – Part 1: Tolerances for linear and angular dimensions without individual tolerance indications*

### 3 Terms and definitions

For the purposes of this document, the following terms and definitions apply.

ISO and IEC maintain terminological databases for use in standardization at the following addresses:

- IEC Electropedia: available at <http://www.electropedia.org/>
- ISO Online browsing platform: available at <http://www.iso.org/obp>

### **3.1**

#### **cable trunking system**

#### **CTS**

assembly comprising a trunking length and possibly other system components to provide an enclosure for the accommodation and laying in of insulated conductors and cables and possibly the accommodation of other electrical equipment

Note 1 to entry: Different types of CTS are shown in Figure 1 and explained in Annex A.

### **3.2**

#### **cable ducting system**

#### **CDS**

assembly comprising a ducting length and possibly other system components to provide an enclosure for the accommodation and drawing in of insulated conductors and cables and possibly the accommodation of other electrical equipment

Note 1 to entry: Different types of CDS are shown in Figure 1 and explained in Annex A.

### **3.3**

#### **system component**

part of the system which includes:

- a) trunking length or ducting length;
- b) trunking fitting or ducting fitting;
- c) fixing device;
- d) apparatus mounting device;
- e) system accessory

Note 1 to entry: A system does not necessarily include all system components a) to e). Different combinations of system components can be used.

### **3.4**

#### **trunking length**

main component of a cable trunking system comprising a base with one or more access covers which may be opened or removed

### **3.5**

#### **ducting length**

main component of a cable ducting system, characterized by a closed non-circular cross section

### **3.6**

#### **fitting**

system component to connect, change direction or terminate trunking lengths or ducting lengths

### **3.7**

#### **fixing device**

system component to secure other system components to the wall, ceiling, floor or other structure

### **3.8**

#### **apparatus mounting device**

system component to accommodate electrical apparatus (switches, socket outlets, circuit-breakers, telephone outlets, etc...) which can be an integral part of electrical apparatus



Note 1 to entry: An apparatus mounting device can also be a fitting, a trunking length, etc.

**3.9**  
**system accessory**

system component which provides a supplementary function

EXAMPLE 1: Examples of system accessories are partition, cable retainer, cable outlet, etc.

**3.10**  
**metallic system component**

system component which consists of metal only

**3.11**  
**non-metallic system component**

system component which consists of non-metallic material only

**3.12**  
**composite system component**

system component comprising both metallic and non-metallic materials

**3.13**  
**non-flame propagating system component**

system component which can catch fire as a result of an applied flame, in which the resulting flame does not propagate and self extinguishes within a limited time after the applied flame is removed

**3.14**  
**external influence**

factor which may affect the system

**3.15**  
**gland**

device designed to permit the entry of a cable or flexible cable into equipment, and which provides sealing and retention

Note 1 to entry: It may also provide other functions such as earthing, bonding, insulation, cable guarding, strain relief or a combination of these.

**3.16**  
**live part**

conductor or conductive part intended to be energized in normal operation, including a neutral conductor, but by convention not a PEN conductor or PEM conductor or PEL conductor

[SOURCE: IEC 60050-826:2004, 826-12-08, modified – Note deleted.]

**3.17**  
**cable anchorage**

system accessory or part of another system component to relieve conductors in terminals and terminations from strain by resisting the pull and twist forces on cable

**3.18**  
**cable restrainer**

system accessory to relieve conductors in terminals and terminations from strain by resisting the pull force on cable or insulated conductors

**3.19**  
**cable retainer**

system accessory for the retention of insulated conductors or cables to prevent them from falling out when the access cover is opened or removed

### **3.20**

#### **grommet**

component or an integral part of an enclosure to support and protect the cable, conduit or ducting or trunking at the point of entry

Note 1 to entry: It may also prevent the ingress of moisture or contaminants.

SEE: Figure 7.

### **3.21**

#### **entry membrane**

component or an integral part of an enclosure to protect the cable, and may be used to support the cable, conduit or ducting or trunking at the point of entry

Note 1 to entry: It may also prevent the ingress of moisture or contaminants. An entry membrane may be part of a grommet.

SEE: Figure 7.

### **3.22**

#### **protecting membrane**

component or an integral part of an enclosure, not to be penetrated in normal use, to provide protection against ingress of water or solid objects and/or to allow the operation of an accessory

SEE: Figure 7.

### **3.23**

#### **gasket**

additional part or material or an integral part placed between mating surfaces of an enclosure which in compression contributes to the achievement of the declared ingress protection

### **3.24**

#### **reaction to fire**

response of a CTS/CDS in contributing by its own decomposition to a fire, to which it is exposed, under specified conditions

### **3.25**

#### **fire resistance**

ability of a CTS/CDS to fulfil for a stated period of time the required stability and/or integrity and/or thermal insulation, and/or other expected duty specified in a standard fire resistance test

Note 1 to entry: Fire resistant (adjective) refers only to this ability.

### **3.26**

#### **skirting CTS/CDS**

CTS/CDS intended to be installed on the lower part of a wall

### **3.27**

#### **dry-treatment of floor**

process for cleaning and/or care by which the floor is treated without liquids or with only a small quantity of liquid

Note 1 to entry: The required agents are applied and spread in such quantities that no pools are formed and soaking of the floor covering does not occur.

EXAMPLE 1: Examples for dry treatment are: Sweeping with a broom or carpet-sweeper, vacuum cleaning, brushing, cleaning with a dry cleaning powder, dry shampoo treatment, wet shampooing of carpets, treatment with cleaning litter (liquid chemical cleaning agent on a solid material used as carrier, e.g. soaked sawdust, damp cloth, etc.)

### 3.28

#### **wet-treatment of floor**

process for cleaning and/or care by which the floor is treated with liquid agents such that pools of liquid, or soaking of the floor covering for a brief period of time, cannot be excluded

EXAMPLE 1: Examples of wet treatment are: wet scrubbing, manual or mechanical wiping.

### 3.29

#### **screen**

##### **conductive screen**

conductive part that encloses or separates electric circuits and/or conductors

[SOURCE: IEC 60050-195:1998, 195-02-38]

### 3.30

#### **protective screen**

##### **electrically protective screen**

conductive screen used to separate an electric circuit and/or conductors from hazardous-live-parts

[SOURCE: IEC 60050-195:1998, 195-06-17]

### 3.31

#### **protective screening**

##### **electrically protective screening**

separation of electric circuits or conductors from hazardous-live-parts by an electrically protective screen connected to the protective-equipotential-bonding system and intended to provide protection against electric shock

[SOURCE: IEC 60050-195:1998, 195-06-18]

### 3.32

#### **protective separation**

##### **electrically protective separation**

separation of one electric circuit from another by means of:

- double insulation; or
- basic insulation and electrically protective screening; or
- reinforced insulation

[SOURCE: IEC 60050-195:1998, 195-06-19]

### 3.33

#### **partition**

##### **partition of an assembly**

part of an assembly separating one compartment from other compartments

[SOURCE: IEC 60050-441:1984, 441-13-06]

### 3.34

#### **internal protective partition**

partition which when used in combination with basic insulation provides electrically protective separation between compartments of the CTS/CDS

## **4 General requirements**

CTS/CDS shall be so designed and constructed that where required they provide reliable mechanical protection to the insulated conductors, cables and possibly other electrical equipment contained therein. Where required, the system shall also provide adequate electrical protection.

Furthermore, the system components shall withstand the stresses likely to occur under classified minimum temperature for storage and transport, installation and application (see Tables 1 and 2) and maximum temperature for application (see Table 3) and during recommended installation practice and usage.

Equipment associated with or incorporated in a system component but which is not a system component, shall and need only comply with the relevant standard of this equipment, if any. However, it may be necessary to include such equipment in a test arrangement for the purpose of testing its interface with the CTS/CDS.

Compliance is checked by carrying out all the tests specified.

## **5 General conditions for tests**

**5.1** Tests according to this document are called type tests.

**5.2** Samples of system components are, hereafter, called samples.

**5.3** Unless otherwise specified, tests are carried out, considering the declared classification and functions of the system, with the CTS/CDS assembled and installed as in normal use according to the manufacturer's instructions.

Tests on non-metallic system components or composite system components shall not commence earlier than 168 h after manufacture. During this period, the samples may be aged according to 10.3.1.1 when required.

**5.4** Unless otherwise specified, the tests are carried out at an ambient temperature of  $20\text{ °C} \pm 5\text{ °C}$ .

**5.5** Samples of trunking lengths or ducting lengths for a given test are taken from different trunking lengths or ducting lengths.

**5.6** Unless otherwise specified, all tests are carried out on new samples.

**5.7** When toxic or hazardous processes are used, precautions shall be taken to safeguard the test personnel.

**5.8** Unless otherwise specified, three samples are subjected to the tests and the requirements are satisfied if all the tests are met.

If only one of the samples does not satisfy a test due to an assembly or a manufacturing fault, that test and any preceding one which may have influenced the results of the test shall be repeated and also the tests which follow shall be carried out in the required sequence on another full set of samples, all of which shall comply with the requirements.

**NOTE** The applicant, when submitting a set of samples, can also submit an additional set of samples which can be used if one sample fail. The testing station will then, without further request, test the additional set of samples and will reject only if a further failure occurs.

If the additional set of samples is not submitted at the same time, the failure of one sample will entail rejection.

## 6 Classification

### 6.1 According to material

Void.

### 6.2 According to resistance to impact for installation and application

6.2.1 CTS/CDS for impact 0,5 J

6.2.2 CTS/CDS for impact 0,7 J

6.2.3 CTS/CDS for impact 1 J

6.2.4 CTS/CDS for impact 2 J

6.2.5 CTS/CDS for impact 5 J

6.2.6 CTS/CDS for impact 10 J

6.2.7 CTS/CDS for impact 20 J

### 6.3 According to temperatures as given in Table 1, Table 2 and Table 3 below

**Table 1 – Minimum storage and transport temperature**

Minimum storage and transport temperature °C
– 45
– 25
– 15
– 5

**Table 2 – Minimum installation and application temperature**

Minimum installation and application temperature °C
– 25
– 15
– 5
+ 5
+ 15

**Table 3 – Maximum application temperature**

Maximum application temperature °C
+ 60
+ 90
+ 105
+ 120

NOTE The application temperatures given in Table 2 and Table 3 are operating temperatures and not ambient temperatures.

#### **6.4 According to resistance to flame propagation**

##### **6.4.1 Flame propagating CTS/CDS**

##### **6.4.2 Non-flame propagating CTS/CDS**

#### **6.5 According to electrical continuity characteristic**

##### **6.5.1 CTS/CDS with electrical continuity characteristic**

##### **6.5.2 CTS/CDS without electrical continuity characteristic**

#### **6.6 According to electrical insulating characteristic**

##### **6.6.1 CTS/CDS without electrical insulating characteristic**

##### **6.6.2 CTS/CDS with electrical insulating characteristic**

NOTE The electrical insulating characteristic provides supplementary insulation when used with insulated conductors and other live parts, if any, provided with basic insulation.

#### **6.7 According to degrees of protection provided by enclosure according to IEC 60529:1989**

##### **6.7.1 According to protection against ingress of solid foreign objects**

IP4X or any higher degree of protection shall not be declared when it relies on butt joint or the accuracy of cutting of ducting lengths or trunking lengths or access covers without providing relevant fittings or assembly means or additional factory prefabricated sealing means.

##### **6.7.2 According to protection against ingress of water**

IPX1 or any higher degree of protection shall not be declared when it relies on butt joint or the accuracy of cutting of ducting lengths or trunking lengths or access covers without providing relevant fittings or assembly means or additional factory prefabricated sealing means.

##### **6.7.3 According to protection against access to hazardous parts**

IPXX-D shall not be declared when it relies on butt joint or the accuracy of cutting of ducting lengths or trunking lengths or access covers without providing relevant fittings or assembly means or additional factory prefabricated sealing means.

#### **6.8 According to protection against corrosive or polluting substances**

Under consideration.

#### **6.9 According to the system access cover retention**

##### **6.9.1 CTS/CDS access cover, which can be opened without a tool**

##### **6.9.2 CTS/CDS access cover, which can only be opened with a tool**

### **7 Marking and documentation**

#### **7.1 Each system component shall be marked with:**

- the manufacturer's or responsible vendor's name or trade mark or identification mark;
- a product identification mark, which may be, for example, a catalogue number, a symbol or the like.

When system components other than trunking length, ducting length and apparatus mounting device are supplied in a package and it is not feasible to have both markings legible due to the small size of the item

- if only one legible marking is feasible, it is sufficient to mark the product identification on the smallest supplied packages, the manufacturer's or responsible vendor's name or trade mark or identification mark being marked on the product,
- if no legible marking is feasible, it is sufficient to place both markings on the smallest supplied package.

Terminals for protective earth shall be marked according to 7.4. This marking shall not be placed on screws or any other easily removable part.

Flame propagating system component shall be clearly identified as being flame propagating on the system component and on the smallest supplied package or label.

When it is not possible to have this identification mean on small system components, due to the small size of the item, it is sufficient to place this identification mean on the smallest supplied package.

Compliance is checked by inspection using one sample.

## 7.2 Marking shall be durable and easily legible.

Compliance is checked by inspection, using normal or corrected vision, without additional magnification and by rubbing the marking for 15 s with a piece of cotton cloth soaked with water and again for 15 s with a piece of cotton cloth soaked with n-hexane 95 % (Chemical Abstracts Service Registry Number, CAS RN, 110-54-3).

NOTE 1 n-hexane 95 % (Chemical Abstracts Service Registry Number, CAS RN, 110-54-3) is available from a variety of chemical suppliers as a high pressure liquid chromatography (HPLC) solvent.

When using the liquid specified for the test, precautions as stated in the relative material safety datasheet provided by the chemical supplier shall be taken to safeguard the laboratory technicians.

Laser marking directly on the product and marking made by moulding, pressing or engraving are not subjected to this test.

Products complying with a previous edition of the standard need not be tested again as this requirement does not have impact on the safety of the product.

The marking surface to be tested shall be dried before rubbing the marking with n-hexane 95 % solvent.

Rubbing shall commence immediately after soaking the piece of cotton, applying a compression force of  $(5 \pm 1)$  N at a rate of about one cycle per second (a cycle comprising a forward and backward movement along the length of the marking). For markings longer than 20 mm, rubbing can be limited to a part of the marking, over a path of at least 20 mm length.

The compression force is applied by means of a test piston according to Figure 10 which is wrapped with cotton comprising of cotton wool covered by a piece of cotton medical gauze.

The test piston shall be made of an elastic material which is inert against the test liquids and has a Shore-A hardness of  $47 \pm 5$  (for example synthetic rubber).

When it is not possible to carry out the test on the specimens due to the shape/size of the product, a suitable piece having the same characteristics as the product can be submitted to the test.

The test shall be carried out on one sample. If the sample does not satisfy the test, the test shall be repeated on two new samples, both of which shall comply with the requirements.

After the test, the marking shall be legible.

NOTE 2 Marking can be applied, for example, by moulding, pressing, engraving, printing, adhesive labels, or water slide transfers.

**7.3** The manufacturer shall provide in his documentation all information necessary for the proper and safe installation and use. It shall include:

- components of the system;
- function of the system components and their assemblies;
- classification of the system in accordance with Clause 6;
- linear impedance, in  $\Omega/m$ , of trunking length or ducting length of system declared according to 6.5.1;
- rated voltage of CTS/CDS declared according to 6.6.2;
- usable cross sectional area, in  $mm^2$ , for cables of the CTS/CDS;



NOTE Certain system components when mounted can reduce the usable cross sectional area for cables.

- instructions to reach the declared classification and functions of the system. These instructions shall include the recommended installation positioning for the CTS/CDS to ensure that the declared IP classification is maintained after installation.

Compliance is checked by inspection.

**7.4** Symbols covered by IEC 60417 shall comply with IEC 60417.

Examples are:

Amperes	A
Volts	V
Frequency	Hz
Alternating current	 or AC
Line	L or L1, L2, L3 etc. in case of more than one
Neutral	N
Protective earth	 IEC 60417-5019 (2006-08)
Fuse	 IEC 60417-5016 (2002-10)
Degree of protection	IPXX (see IEC 60529)



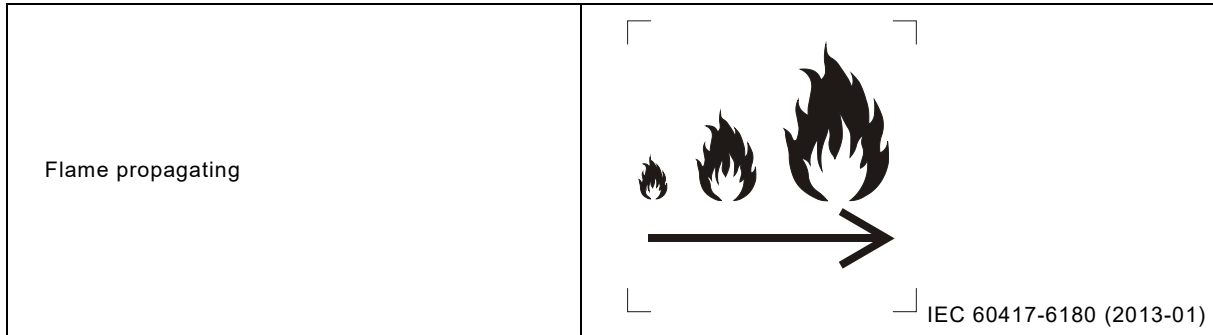

For the marking of rated current and rated voltage the figures may be used alone. These figures may be placed on one line separated by an oblique line or the figures for rated current may be placed above the figures for rated voltage, separated by a horizontal line.

The marking for the nature of supply shall be placed next to the marking for rated current and rated voltage.

The marking for current, voltage and nature of supply may be, for example, as follows:

$$16 \text{ A } 440 \text{ V } \sim \text{ or } 16/440 \sim \text{ or } \frac{16}{440} \sim$$

## 8 Dimensions

Dimensions shall comply with the requirements of the relevant IEC 61084-2 part.

## 9 Construction

### 9.1 Sharp edges

Any surface or edge shall not damage the insulated conductors or cables.

Compliance is checked by inspection, if necessary after cutting the samples apart.

Screws, studs or other securing devices provided shall be fitted so as not to damage the insulated conductors or cables.

Compliance is checked by inspection.

### 9.2 Apparatus mounting

If the CTS/CDS is provided with means for the mounting of apparatus, these means shall adequately secure this apparatus.

Compliance is checked by the test of 10.5.

### 9.3 Means for protective separation and/or retention

If the CTS/CDS is provided with means for the protective separation and/or retention, these means shall have adequate mechanical performance to fulfil their function.

Compliance is checked by the tests of 10.2.

## **9.4 Mechanical connections**

**9.4.1** Screwed connections and other mechanical connections shall withstand the mechanical stresses during installation and normal use.

Screws shall be one or more of the following:

- a) ISO-metric threads;
- b) thread forming type;
- c) thread cutting type if suitable design provisions are made;
- d) threads other than a) to c) as specified by the manufacturer.

Mechanical connections of CTS used to allow the laying in of insulated conductors or cables or relocation of an apparatus shall be intended for re-use.

Compliance is checked by the tests of 9.4.2, 9.4.3 and 9.4.4 respectively.

**9.4.2** Screws intended for re-use shall not be tightened by sudden or jerky motions.

To test the screw it shall be tightened and removed as follows:

- 10 times for metal screws in engagement with a thread of non-metallic material and for screws of non-metallic material;  
or
- 5 times in all other cases.

The test is carried out using a suitable screwdriver or spanner to apply a torque, as specified by the manufacturer. In case the manufacturer does not specify the torque, the values of Table 4 apply.

After the test there shall be no damage that will impair the further use of the screwed connection.

**Table 4 – Torque values for the test of screwed connections**

Nominal diameter of thread mm	Torque Nm		
	I	II	III
Up to and including 2,8	0,2	0,4	0,4
Over 2,8 up to and including 3,0	0,25	0,5	0,5
Over 3,0 up to and including 3,2	0,3	0,6	0,6
Over 3,2 up to and including 3,6	0,4	0,8	0,8
Over 3,6 up to and including 4,1	0,7	1,2	1,2
Over 4,1 up to and including 4,7	0,8	1,8	1,8
Over 4,7 up to and including 5,3	0,8	2,0	2,0
Over 5,3 up to and including 6,0	1,2	2,5	3,0
Over 6,0 up to and including 8,0	2,5	3,5	6,0
Over 8,0	3,0	4,0	10,0

NOTE Column I applies to screws which cannot be tightened by means of a screwdriver with a blade wider than the diameter of the screw.

Column II applies to other screws that are tightened by means of a screwdriver.

Column III applies to screws and nuts that are tightened by means other than a screwdriver.

**9.4.3** Mechanical connections intended for re-use other than screwed connections, shall be fitted and removed 10 times.

After the test, there shall be no damage to impair the further use of the mechanical connection.

**9.4.4** Mechanical connections not intended for re-use are checked by inspection.

## **9.5 Accessible conductive parts**

**9.5.1** Accessible conductive parts of CTS/CDS shall comply with 9.5.2 unless they comply with 9.5.3.

**9.5.2** Accessible conductive parts of CTS/CDS installed according to the manufacturer's instructions, which are likely to become live in the event of an insulation fault, shall have the provision for reliable connection to earth.

If precautions are taken in order to prevent creepage distances and clearances from becoming less than 3 mm, even if a conductor should become loose from its terminal, the accessible conductive part is not considered likely to become live.

Protection against electric shock in case of a fault may be omitted for accessible conductive parts which, owing to their reduced dimensions (up to approximately 50 mm × 50 mm) or their disposition, cannot be gripped or come into significant contact with a part of the human body and provided that connection with a protective conductor could only be made with difficulty or would be unreliable.

NOTE This requirement applies, for example, to bolts, rivets, nameplates and cable clips.

Compliance is checked by inspection, measurement and if necessary by the appropriate test of 11.1.3 or 11.2. Before the test the samples are subjected to conditioning according to 11.1.2 respectively 11.2.2.

**9.5.3** Accessible conductive parts need not have provision for connection to earth if they are insulated from live parts with supplementary or reinforced insulation used to form barriers or linings which shall be designed in such a way that:

- they cannot be removed without being permanently damaged or,
- they cannot be replaced in an incorrect position or,
- if omitted, the system is rendered inoperable or manifestly incomplete.

Compliance is checked by inspection.

NOTE For particular application, equipotentially bonding these parts or connecting these parts to the earthing conductor can be used for functional purposes such as EMC.

## **9.6 Equipotential bonding**

**9.6.1** The manufacturer shall declare if the CTS/CDS can be used for equipotential bonding.

**9.6.2** If there is a provision for bonding, compliance is checked by the tests of 11.1.3. Before the test the sample is subjected to conditioning of 11.1.2.

## **9.7 Access to live parts**

**9.7.1** CTS/CDS shall be so designed that when they are installed and fitted with apparatus and/or other electrical equipment as in normal use, live parts are not accessible.

Compliance is checked by inspection and, if necessary, by the tests of 9.7.2, 9.7.3 and 9.7.4 on the sample installed and fitted with apparatus and/or other electrical equipment as in normal use.

The tests are carried out after all parts removable without tools are removed.

**9.7.2** The test probe B of IEC 61032:1997 is applied in every possible position, an electrical indicator with a voltage not less than 40 V and not more than 50 V being used to show contact with the relevant part.

**9.7.3** Non-metallic system components and composite system components are subjected to the following additional test, which is carried out at the temperature declared according to Table 3 with a tolerance of  $\pm 2$  °C.

The sample is subjected for 1 min to a force of 50 N applied through the tip of test probe 11 of IEC 61032:1997.

This test probe 11 with an electrical indicator as described in 9.7.2 is applied to all places where yielding of insulating material could impair the safety of the system but is not to be applied to knockouts, membranes and the like.

During this test system components and their associated fixing devices shall not deform to such an extent that live parts can be touched with the test probe 11.

**9.7.4** Knockouts are subjected for 1 min to a force of 10 N applied through the tip of test probe 11 of IEC 61032:1997.

During this test, knockouts shall not break.

## 9.8 Inlet openings

Inlet openings, if any, shall allow the introduction of conduits and/or the like, or the protective covering of the cable at least 1 mm into the system component, in order to maintain the mechanical protection.

Inlet openings for conduits shall be capable of accepting conduit sizes according to IEC 60423:2007.

Compliance is checked by inspection and measurement.

## 9.9 Membranes

**9.9.1** Membranes and the like which prevent access to live parts shall withstand the mechanical stresses occurring in normal use.

The manufacturer shall declare the dimensions of the cables which may be installed in the entry membranes.

Compliance is checked by the test of 9.9.2.

**9.9.2** Membranes are tested when assembled in the system. The sample is placed for 2 h in a heating cabinet the temperature being maintained at the value declared according to Table 3 with a tolerance of  $\pm 2$  °C. Immediately after this period a force of 30 N is applied for 5 s to various regions of the membrane through the tip of test probe 11 of IEC 61032:1997. For membranes likely to be subjected to an axial pull force in normal use, an axial pull force of 30 N is applied for 5 s.

During this test, the membranes shall not deform to such an extent that live parts become accessible and the membranes shall not become detached.

**9.9.3** Entry membranes shall allow the introduction of cables into the system at the minimum installation temperature declared according to Table 2.

Compliance is checked by the test of 9.9.4.

**9.9.4** The system component shall be fitted with entry membranes which have not been subjected to any ageing treatment, those without openings being suitably pierced.

The sample is then kept for 2 h in a refrigerator at the temperature declared according to Table 2 with a tolerance of  $\pm 2$  °C.

After this period the sample is removed from the refrigerator, and immediately afterwards, while the sample is still cold, it shall be possible to introduce through the entry membranes without undue force, cables having the largest outside dimension as declared.

**9.9.5** After the tests of 9.9.2 and 9.9.4, the membranes shall show no cracks or similar damages visible to normal or corrected vision without magnification that are likely to impair safety.

## 9.10 Cable restrainer

Cable restrainers, if any, shall relieve conductors from strain in terminals or terminations by resisting the pull force on cable or insulated conductors.

It shall be clear or indicated in the manufacturer's instructions how the relief from strain is intended to be effected.

Cable restrainers shall:

- be suitable for the different types of cable and the different types and number of insulated conductors according to the manufacturer's instructions,
- be such that at least part of it is integral with or permanently fixed to a system component,
- not use makeshift method such as tying cable or insulated conductor in a knot or tying the ends with string,
- not impair electrical safety.

Compliance is checked by inspection and by the following test.

The cable restrainer is fitted with a cable of the smallest outside dimension or with insulated conductors of the smallest outside dimension for which it is intended. The screws, if any, are tightened with a torque as specified by the manufacturer. Where the manufacturer does not specify the torque the values of Table 4 apply.

An axial pull force of  $20 \text{ N} \pm 1 \text{ N}$  is applied for  $60 \text{ s} \pm 5 \text{ s}$  to the cable or to each insulated conductor.

The test is then repeated with the cable restrainer fitted with a cable of the largest outside dimension or with insulated conductors of the largest outside dimension for which it is intended.

After any of the tests:

- the longitudinal displacement of the cable or any insulated conductor in the restrainer shall not be more than 2 mm; and
- electrical safety shall not be impaired.

### **9.11 Cable anchorage**

Cable anchorage, if any, shall relieve conductors from strain in terminals or terminations by resisting the pull and twist forces on cable.

It shall be clear or indicated in the manufacturer's instructions how the relief from strain is intended to be effected.

Cable anchorage shall:

- be suitable for the different types of cable according to the manufacturer's instructions;
- be such that at least part of it is integral with or permanently fixed to a system component;
- not use makeshift method such as tying cable in a knot or tying the ends with string;
- not impair electrical safety;

Compliance is checked by inspection and by the following test.

The effectiveness of the cable anchorage is checked by means of apparatus as shown in Figure 8 and Figure 9.

The cable anchorage is fitted with a cable of the smallest outside dimension for which it is intended. The screws, if any, are tightened with a torque as specified by the manufacturer. Where the manufacturer does not specify the torque the values of Table 4 apply.

The cable is then subjected 50 times for 1 s to a pull force as specified in Table 5 and immediately afterwards the cable is subjected to a torque not less than the relevant value specified in Table 5 for  $15 \text{ s} \pm 1 \text{ s}$  applied as near as practicable to the cable entry.

**Table 5 – Forces and torques to be applied to cable anchorage**

Minimum outside dimension of cable mm	Force N	Torque Nm
Up to and including 5	40 ± 2	0,05
Up to and including 8	50 ± 2	0,10
Up to and including 11	60 ± 2	0,15
Up to and including 16	80 ± 2	0,35
Above 16	100 ± 2	0,42

The test is then repeated with the cable anchorage fitted with a cable of the largest outside dimension for which it is intended.

After any of the tests:

- the longitudinal displacement of the cable in the cable anchorage shall not be more than 2 mm; and
- the cable shall not have turned in the cable anchorage more than 2 revolutions; and
- electrical safety shall not be impaired.

## 10 Mechanical properties

### 10.1 Mechanical strength

CTS/CDS shall have adequate mechanical strength.

*Compliance is checked by the tests of 10.2 to 10.5.*

### 10.2 Cable support test

The test is described in the relevant IEC 61084-2 part.

### 10.3 Impact test

#### 10.3.1 Impact test for storage and transport

**10.3.1.1** The test is carried out on samples of trunking lengths or ducting lengths each 250 mm ± 5 mm long.

Before the test, non-metallic system components and composite system components are aged at the temperature declared according to Table 3 with a tolerance of ± 2 °C for 168 h continuously.

**10.3.1.2** The test apparatus consists basically of a hammer which falls freely from rest through a vertical height on to an intermediate part placed on the sample held in a horizontal plane.

The following conditions are also complied with:

- the fall of the hammer is along a guideway, for example a tube, with negligible braking;
- the guideway does not rest on the sample;
- the mass of the hammer is 0,5 kg + 0,005 / 0 kg and the fall height is 100 mm ± 1 mm;
- the intermediate part is made in a steel 20 mm diameter cylinder. Its lower surface has a 300 mm bending radius and its mass is 100 g ± 5 g.

NOTE An example of test apparatus is shown in Figure 2.

The samples are placed in a refrigerator at the temperature declared according to Table 1 with a tolerance of  $\pm 2$  °C.

**10.3.1.3** After 2 h, each sample is, in turn, removed from the refrigerator and immediately placed in position in the test apparatus.

At  $12 \text{ s} \pm 2 \text{ s}$  after the removal of the sample from the refrigerator the hammer is allowed to fall so that an impact is applied as far as possible perpendicular to the region likely to be the weakest accessible region. Compliance with impact applied before 10 s provides also compliance with this test of the standard.

This test is not applied to knockouts, membranes and the like, and within 50 mm of each end.

**10.3.1.4** After the test the samples shall show no signs of disintegration nor there be any cracks or similar damages visible to normal or corrected vision without magnification that are likely to impair safety.

NOTE Any cracks in partitions which are not likely to impair the electrical safety or normal use are ignored. Electrical safety can be impaired when the impact creates a sharp edge on a partition which can damage insulated conductors or cables (see 9.1).

### **10.3.2 Impact test for installation and application**

The test is carried out according to the resistance to impact declared according to Table 6, at the temperature declared according to Table 2 with a tolerance of  $\pm 2$  °C.

**Table 6 – Impact test values**

Resistance to impact classification	Equivalent mass	Fall height $\pm 1\%$
	kg	mm
Impact 0,5 J	0,25	200
Impact 0,7 J	0,25	280
Impact 1 J	0,25	400
Impact 2 J	0,50	400
Impact 5 J	1,70	300
Impact 10 J	5,00	200
Impact 20 J	5,00	400

The test is described in the relevant IEC 61084-2.

In addition, the manufacturer may declare the CTS/CDS IK code according to IEC 62262 and Annex B of this document.

### **10.4 Linear deflection test**

This test is described in the relevant IEC 61084-2 part.

### **10.5 External load test**

#### **10.5.1 Fixing test for apparatus mounting of socket outlets**

An apparatus-mounting device is fitted on a sample of the relevant system component, in the middle of its length unless otherwise stated in the manufacturer's instructions. When the relevant system component is a trunking length or a ducting length, the sample is



250 mm  $\pm$  5 mm long or 100 mm  $\pm$  5 mm longer than the apparatus mounting device, whichever is the greater.

NOTE Other system components can be included, if necessary, to prevent movements of the apparatus mounting device. These system components, if any, are the system components used to terminate the trunking length or ducting length. When there are no such system components, those chosen by the manufacturer are used.

If the results of the tests are dependent on the temperature the tests are carried out at the temperature of 60 °C  $\pm$  2 °C.

A pull and a press force of 1,5 times the maximum withdrawal force of the plug is applied in turn to the apparatus fixing of the apparatus mounting device for 1 min in the most unfavourable position and direction within an angle of 45° to 90° from the front surface.

The maximum withdrawal force for the plug is taken from the relevant national standard. When there is no relevant standard, a maximum withdrawal force of 50 N is used.

After the test, electrical safety shall not be impaired. In case of doubt, the test of 14.1.4 shall be carried out on the assembly to check that the declared degree of protection against access to hazardous parts is maintained. The declared degree of protection against access to hazardous parts is either the additional letter directly declared by the manufacturer according 6.7.3, if any, or the degree of protection against access to hazardous parts indirectly declared by the manufacturer according to 6.7.1.

Immediately after this test, the apparatus mounting device is subjected to a torque of 3,0 Nm  $\pm$  0,2 Nm, clockwise and anticlockwise. The duration of the test is 1 min in each direction.

During the test, the apparatus mounting device shall not turn more than an angle of 15° from its initial position and after the test electrical safety shall not be impaired.

#### **10.5.2 Fixing test for apparatus mounting other than socket outlets**

For other apparatus, only a pull and press force test is carried out according to the test of 10.5.1 with a force of 50 N  $\pm$  2 N.

#### **10.6 System access cover retention**

Access cover of system components of systems classified according to 6.9.2 shall not be capable of being opened without a tool.

Compliance is checked by the following test.

Before the test, non metallic system components and composite components are aged at the temperature declared according to Table 3 with a tolerance of  $\pm$  2 °C for (168  $\pm$  4) h continuously.

The test is carried out on an assembly made of one or more trunking lengths or ducting lengths with the relevant system component, if any, to fulfil the various functions of the system and prepared according to the manufacturer's instructions. More than one assembly may be necessary to fulfil the various functions of the system. In each direction, the length  $L$  of trunking length or ducting length coming out of the functional area associated with the function of the system is as long as the width  $W$  of the trunking length or ducting length, or 250 mm, whichever is the greater. The tolerance of  $L$  is  $\pm$  25 mm.

The samples are mounted on a rigid smooth support such as a plywood board 16 mm thick, with a 50 mm minimum spacing between the assembly and the edge of the support.

Other system components may be included, if necessary, to prevent movements. These system components are the system components to terminate the trunking length or ducting length, if any. When there is no such system component, a system component chosen by the manufacturer is used.

Without the use of a tool, reasonable manual effort is made to open the access cover. Reasonable effort is intended to simulate action and instinctive handling likely to occur.

After the test, the access cover shall remain secured.

## **11 Electrical properties**

### **11.1 Electrical continuity**

#### **11.1.1 General**

CTS/CDS declared according to 6.5.1 shall have adequate conductivity.

NOTE 1 CTS/CDS which are so designed that the requirements of IEC 60364-5-54:2011 are complied with, can be used as an equipotential bonding and/or protective conductor.

NOTE 2 Additional requirements for the use of CTS/CDS as a protective conductor are under consideration.

Compliance is checked by the tests of 11.1.3 carried out after conditioning according to 11.1.2 on sample arrangements having a minimum length of 1 m at middle line, each made of one or two trunking lengths or ducting lengths with the relevant system component, if any.

Where electrical connections include screwed connections, the screwed connections are tightened by applying the torque specified by the manufacturer. In case the manufacturer does not specify the torque, 2/3 of the values of Table 4 apply.

#### **11.1.2 Preparation and conditioning**

All grease is removed from the parts to be tested, by cleaning with white spirit with a kauri-butanol value of  $35 \pm 5$ . The samples are then immersed for 10 min in a 10 % solution of ammonium chloride in water at the temperature of  $20 \text{ }^\circ\text{C} \pm 5 \text{ }^\circ\text{C}$ . Without drying, but after shaking off any drops, the samples are then placed for 10 min in a box containing air saturated with moisture at the temperature of  $20 \text{ }^\circ\text{C} \pm 5 \text{ }^\circ\text{C}$ .

The samples shall then be dried for 10 min in a heating cabinet at the temperature of  $100 \text{ }^\circ\text{C} \pm 5 \text{ }^\circ\text{C}$  and are left at room temperature for 24 h.

#### **11.1.3 Electrical impedance tests**

##### **11.1.3.1 General**

A current derived from an AC source having a no-load voltage not exceeding 12 V and equal to  $25 \text{ A} \pm 1 \text{ A}$  at the nominal frequency of 50 Hz is passed through the four sample arrangements of 11.1.3.2 to 11.1.3.5, and the voltage drop is measured.

##### **11.1.3.2 Impedance of ducting length or trunking length**

The test is carried out on one or more of the following samples according to the manufacturer's declaration:

- ducting length;
- base of trunking length;
- access cover of trunking length;

- trunking length.

The voltage drop  $\Delta V$  is measured between two convenient points as shown in Figure 6a. The impedance  $Z_1$  is calculated using the following formula:

$$Z_1 = \frac{\Delta V}{I \times d_1} (\Omega/\text{m})$$

where

$I$  is the current, and

$d_1$  is the distance between the two measurement points.

$Z_1$  shall not be greater than the declared value.

#### 11.1.3.3 Impedance of a joint

The test is carried out on the following samples:

- two assembled trunking lengths or assembled ducting lengths;
- trunking length or ducting length assembled with a different system component.

The voltage drop  $\Delta V$  is measured as shown in Figure 6b between two convenient points each on one side of the joint and separated by a distance of at least 50 mm from the coupling area. The impedance  $Z_2$  is calculated using the following formula:

$$Z_2 = \frac{\Delta V}{I} - d_2 \times Z_1 (\Omega)$$

where

$Z_1$  is the impedance of the relevant ducting length or trunking length as calculated in 11.1.3.2;

$Z_2$  shall not be greater than 50 m $\Omega$ .

#### 11.1.3.4 Impedance of connection between trunking base and access cover

If the manufacturer declares that the system provides appropriate electrical continuity between the base and access cover for good earthing then the following test is carried out on one of the following samples:

- one access cover having a length equal to the smallest length of access cover allowed by the manufacturer's instruction mounted on a base as long as the access cover but at least 100 mm long;
- system component.

The voltage drop  $\Delta V$  is measured as shown in Figure 6c between both sides of the connection. The impedance  $Z_3$  is calculated using the following formula:

$$Z_3 = \frac{\Delta V}{I} (\Omega)$$

$Z_3$  shall not be greater than 50 m $\Omega$ .

### 11.1.3.5 Impedance of the connection of the earthing terminal or termination

The test is carried out on system components fitted or intended to be fitted with earthing terminal or termination.

The voltage drop  $\Delta V$  is measured as shown in Figure 6d between the earthing terminal or termination and a point separated by a distance  $d_3$  of 10 mm to 20 mm from the edge of the earthing terminal or termination along the line of current flow. The impedance  $Z_4$  is calculated using the following formula:

$$Z_4 = \frac{\Delta V}{I} (\Omega)$$

$Z_4$  shall not be greater than 50 m $\Omega$ .

## 11.2 Electrical insulation

### 11.2.1 Solid insulation

System components, which form part of the enclosure, of CTS/CDS declared according to 6.6.2 shall be capable of withstanding electrical stress, which is likely to occur.

Internal protective partitions, declared by the manufacturer as providing supplementary insulation, shall be capable of withstanding electrical stress, which is likely to occur.

Compliance is checked by the tests according to 11.2.3 and 11.2.4 using the same sample, after conditioning and preparation according to 11.2.2.

For trunking lengths and ducting lengths the samples are 250 mm  $\pm$  5 mm long. Other system components are tested as supplied. Where internal protective partitions are declared by the manufacturer as providing supplementary insulation, the solid insulation is tested in the same way as system components forming part of the enclosure.

### 11.2.2 Conditioning and preparation

The humidity treatment is carried out in a humidity cabinet with a relative humidity between 91 % and 95 % at a temperature,  $t$ , maintained within  $\pm 1$  °C of any convenient value between 25 °C and 30 °C.

Before being placed in the humidity cabinet, the samples are brought to a temperature between  $t$  and  $t + 4$  °C. This may be achieved by keeping them at this temperature for at least 4 h before the humidity treatment.

The samples are kept in the cabinet for 120 h.

Immediately after conditioning, two conductive foils used as electrodes are applied, one to the outer surface and one to the inner surface of the sample to provide an area of overlap not less than 2 500 mm<sup>2</sup>. When 2 500 mm<sup>2</sup> cannot be achieved, the maximum possible area of overlap is used.

NOTE The foils can be smaller than the sample and moved together so as to test different areas of the sample. It is not necessary to repeat the test on areas of the sample having the same characteristics.

The foils are pushed into corners and the like with a maximum force of 10 N so as to provide good contact with the surface, using the test probe 11 of IEC 61032:1997, if necessary after cutting the sample.

A distance of at least 2 mm from edges and openings is maintained in order to prevent short circuit between the electrodes through the air or along the surface of the sample.

### 11.2.3 Insulation resistance test

The insulation resistance is measured by applying between the electrodes a DC voltage of  $500\text{ V} \pm 25\text{ V}$ . The measurement is made  $60\text{ s} (+ 10/0)\text{ s}$  after the application of the voltage. The insulation resistance shall be not less than  $100\text{ M}\Omega$ .

### 11.2.4 Dielectric strength test

Immediately after the test of 11.2.3, a voltage of  $(2 U_n + 1\ 000)\text{ V}$ , where  $U_n$  is the rated voltage, of substantially sine-wave form and having a nominal frequency of  $50\text{ Hz}$ , is then applied between electrodes.

Initially not more than half the voltage is applied and this is raised to the test voltage as rapidly as possible without transient overvoltage. The voltage is maintained for  $5\text{ s} (+ 1/0)\text{ s}$ .

The high-voltage transformer used for the test shall be so designed that, when the output terminals are short-circuited after the output voltage has been adjusted to the appropriate test voltage, the output current is of at least  $200\text{ mA}$ .

The overcurrent relay shall not trip when the output current is less than  $100\text{ mA}$ .

No flashover or breakdown shall occur during the test.

NOTE 1 The r.m.s. value of the test voltage applied is measured within  $\pm 3\%$ .

NOTE 2 Glow discharges without a drop in voltage are disregarded.

## 12 Thermal properties

### 12.1 Resistance to heat

#### 12.1.1 General

Non-metallic or composite system components shall have adequate resistance to heat.

Compliance is checked by test of 9.7, 9.9, 10.5, 12.1.2 and 12.1.3.

NOTE For the purpose of the tests according to 12.1.2 and 12.1.3, insulated conductors and cables are not considered to be current carrying parts.

#### 12.1.2 Test for non-metallic or composite system components necessary to retain current-carrying parts in position

Non-metallic or composite system components necessary to retain current-carrying parts in position are subjected to a ball-pressure test by means of the apparatus shown in Figure 5.

Before the test is started, the ball and the support on which the sample shall be placed are brought to the temperature specified. The part under test shall be placed on a  $3\text{ mm}$  thick steel plate in direct contact with it so as to be supported to withstand the test force.

When it is not possible to carry out the test on the sample, the test shall be carried out on a piece of the same material at least  $2\text{ mm}$  thick.

The surface of the part to be tested is placed in the horizontal position and a steel ball of  $5\text{ mm}$  diameter is pressed against the surface with a force of  $20\text{ N}$ .

The test is carried out in a heating cabinet at the temperature of  $125\text{ }^\circ\text{C} \pm 2\text{ }^\circ\text{C}$ . After  $1\text{ h}$ , the ball is removed from the sample which is then cooled down within  $10\text{ s}$  to approximately room temperature by immersion in cold water.

The diameter of the impression caused by the ball is measured and shall not exceed 2 mm.

### 12.1.3 Test for non-metallic or composite system components not necessary to retain current-carrying parts in position

Non-metallic or composite system components not necessary to retain current-carrying parts in position, but in contact with them and non-metallic or composite system components which retain parts of the protective earthing circuit, are subjected to the ball-pressure test of 12.1.2 but the test is carried out at the temperature of  $70\text{ °C} \pm 2\text{ °C}$ .

## 13 Fire hazard

### 13.1 Reaction to fire

#### 13.1.1 Initiation of fire

Non-metallic system components and composite system components which might be exposed to abnormal heat due to electrical effects and deterioration of which might impair the safety of the system, shall not initiate fire.

Compliance is checked by the following test.

The glow-wire test is performed according to Clauses 4 to 10 of IEC 60695-2-11:2014 under the following conditions:

- for non-metallic or composite parts of system components necessary to retain current-carrying parts in position, by the test carried out at the temperature of  $850\text{ °C}$ ;
- for non-metallic or composite parts of system components not necessary to retain current-carrying parts and parts of the earthing circuit in position, but in contact with them, by the test carried out at the temperature of  $650\text{ °C}$ .

Small parts, such as washers, are not subjected to the test of this subclause.

The tests are not carried out on parts of ceramic material.

If possible, the sample should be a complete system component.

If the test cannot be carried out on a complete system component, a suitable part may be cut from it for the purpose of the test.

The test is carried out on one sample that is permitted to be tested at more than one point.

In case of doubt, the test shall be repeated on two further samples.

The test is carried out by applying the glow-wire once for  $30\text{ s} \pm 1\text{ s}$ .

The sample is regarded as having passed the glow-wire test if

- a) there is no ignition, or
- b) all of the following situations apply when ignition has occurred:
  - i) if flames or glowing combustion of the test specimen extinguish within 30 s after removal of the glow wire, i.e.  $t_E \leq t_A + 30\text{ s}$ ; and
  - ii) the specified layer placed underneath the test specimen does not ignite.

### 13.1.2 Contribution to fire

Non-metallic system components and composite system components shall not actively contribute to fire.

Compliance is checked by the following test.

The glow-wire test is performed according to Clauses 4 to 10 of IEC 60695-2-11:2014 on all parts under the conditions specified in 13.1.1 at the temperature of 650 °C.

Parts, which have already been tested at 650 °C or 850 °C according to 13.1.1, are not tested again at this temperature.

Small parts and parts in ceramic material are not tested.

### 13.1.3 Spread of fire

Non-flame propagating CTS/CDS declared according to 6.4.2 shall either not ignite or if ignited, shall not continue to burn when the source of ignition is removed.

Non-metallic system component or metallic system component coated in paint or any other substance, which is likely to affect its resistance to flame propagation, is to be considered as a composite component and tested accordingly.

Compliance is checked:

- for trunking lengths or ducting lengths of non-metallic or composite material by the following test,
- for other system components of non-metallic or composite material by the test of 13.1.1 at the temperature of 650 °C.

System components, which have already been tested at 650 °C or 850 °C according to 13.1.1, are not tested again at this temperature.

The test is carried out with a length of 675 mm  $\pm$  10 mm. If partitions are not integral with the sample, a partition shall be mounted on the trunking length or ducting length. Other parts may be added to the sample at the request of the manufacturer.

The test is performed using the burner specified in IEC 60695-11-2.

The sample is placed as shown in Figure 3 in a rectangular metal enclosure with an open front face as shown in Figure 4 in an area substantially free from draughts. It shall be clamped at both ends, in order to prevent distortion or movement of the sample itself under flame application conditions.

The burner is positioned in such a way that the axis forms an angle of 45°  $\pm$  2° with the vertical one. The flame is applied to the sample so that the distance from the top of the burner tube to the sample measured along the axis of the burner tube is 100 mm  $\pm$  10 mm, and the axis of the flame intersects with the surface of the sample at a point 100 mm  $\pm$  5 mm above the upper extremity of the lower clamp. The upper extremity of the lower clamp is 500 mm  $\pm$  10 mm above the internal lower surface of the enclosure as shown in Figure 3.

The internal lower surface of the enclosure shall be covered with a piece of soft whitewood board, approximately 10 mm thick, covered with a single layer of wrapping paper.

The sample is subjected to the exposure of the flame for 60 s  $\pm$  2 s.

The sample is regarded as having passed the test if:

- it does not ignite, or if
- in the case of ignition, the following three conditions are fulfilled:
  - 1) the flame extinguishes within 30 s after removal of the test flame;
  - 2) there is no ignition of the wrapping paper or scorching of the board;
  - 3) after wiping of the sample, there is no evidence of burning or charring above 50 mm below the lower extremity of the upper clamp.

#### **13.1.4 Additional reaction to fire characteristics**

Under consideration.

#### **13.2 Resistance to fire**

Under consideration.

### **14 External influences**

#### **14.1 Degree of protection provided by enclosure**

##### **14.1.1 General**

CTS/CDS, when assembled and installed according to the manufacturer's instructions, shall provide adequate protection according to the classification declared by the manufacturer with a minimum of IP20.

Compliance is checked by the tests of 14.1.2, 14.1.3 and 14.1.4.

The system declared by the manufacturer is tested in the most unfavourable installation positions according to the manufacturer's instruction. Each assembly is made of one or more trunking lengths or ducting lengths of 250 mm  $\pm$  5 mm with the relevant system component, if any, to fulfil the various functions of the system. More than one assembly may be necessary to fulfil the various functions of the system. Where necessary, the open ends of the assembly are plugged or are not part of the test.

The following ageing treatment is carried out before the tests of 14.1.2, 14.1.3 and 14.1.4 on assemblies which include a non-metallic system component or a composite system component.

The assemblies are placed in a heating cabinet for (168  $\pm$  4) h at the maximum application temperature as declared by the manufacturer according to Table 3 with a tolerance of  $\pm$  2 °C.

The assemblies are then removed from the cabinet and kept at room temperature for not less than 24 h.

Assemblies designed for opening are opened and closed five times.

##### **14.1.2 Protection against ingress of solid foreign objects**

The assembly is tested in accordance with the appropriate test of IEC 60529:1989. For numeral 5, category 2 applies.

The assembly tested for numeral 5 or 6 passes the test if there is no ingress of dust visible to normal or corrected vision without magnification.



#### 14.1.3 Protection against ingress of water

The assembly is tested in accordance with the appropriate test of IEC 60529:1989. For numeral 3 and 4 the oscillating tube according to Figure 4 of IEC 60529:1989 is used unless the dimensions of the assembly imply using the spray nozzle according to Figure 5 of IEC 60529:1989.

The assembly tested for numeral 1 and above passes the test if there is no ingress of water in hazardous quantity.

The quantity in mm<sup>3</sup> is considered as non-hazardous when the volume of water which has penetrated the assembly is less than:

$5 \times 10^{-3} \times \text{cross sectional area (mm}^2) \times [250 \text{ (mm)} \times \text{number of trunking lengths or ducting lengths} + \text{the length (mm) along the centre line of the relevant system component if any}]$ .

The measurement of the volume of water is made with a syringe after wiping of the exterior of the assembly and careful removal of the access covers, if any.

#### 14.1.4 Protection against access to hazardous parts

The assembly is tested in accordance with the appropriate test of IEC 60529:1989.

The probe shall not enter the space for the accommodation of circuits.

#### 14.2 Protection against corrosive or polluting substances

Under consideration.

### 15 Electromagnetic compatibility

Products covered by this document are, in normal use, passive in respect of electromagnetic influences (emission and immunity).

NOTE When products covered by this document are installed as part of a wiring installation, the installation can emit or can be influenced by electromagnetic signals. The degree of influence will depend on the nature of the installation within its operating environment and the apparatus connected by the wiring.



Dimensions in millimetres

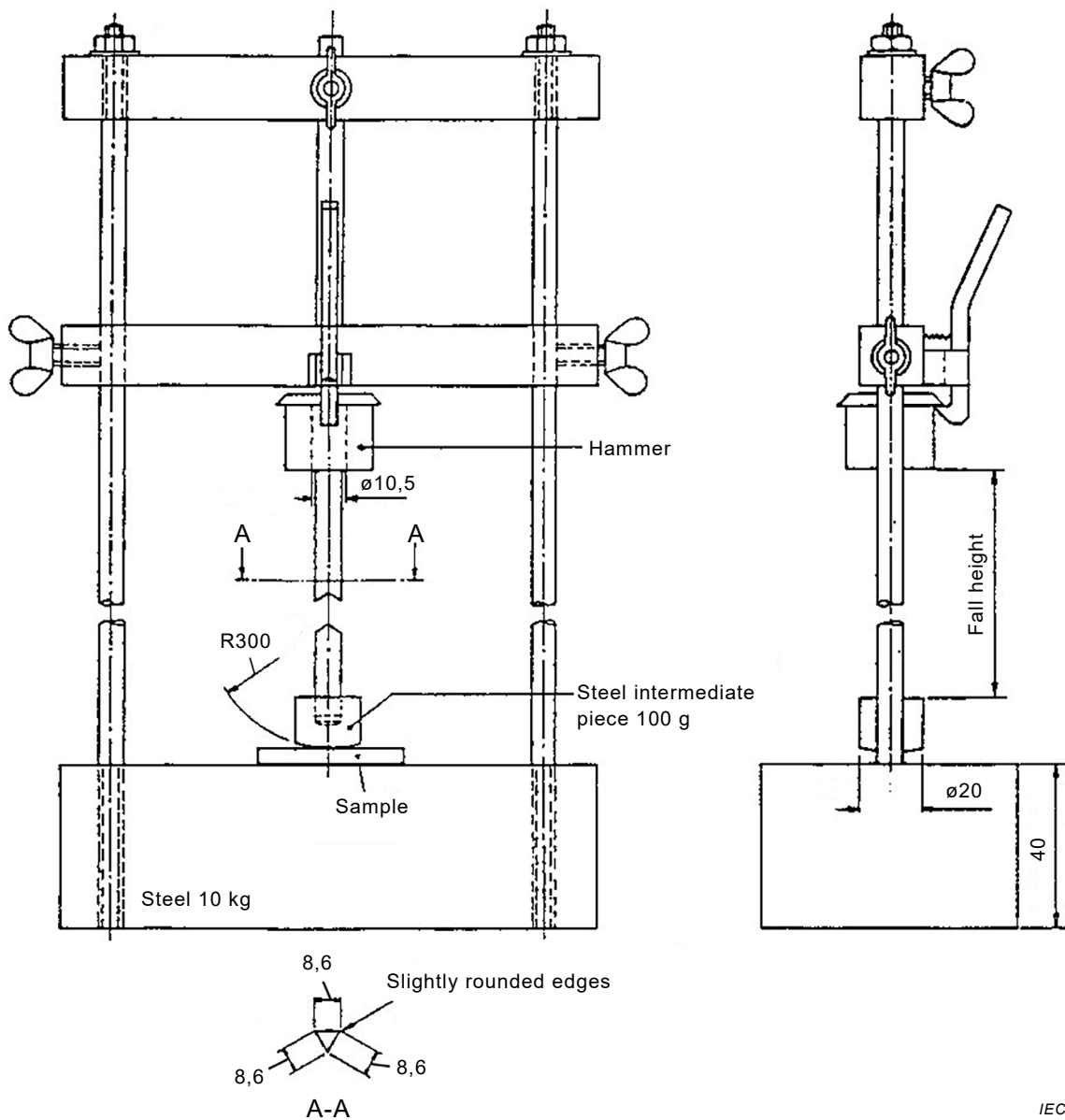

This drawing is not intended to govern design except as regards the dimensions shown.

NOTE 1 The base plate of 40 mm thickness can be replaced by two plates of 20 mm thickness.

NOTE 2 Unspecified tolerances are as per class m of ISO 2768-1.

NOTE 3 Dimensions in mm.

**Figure 2 – Example of impact test apparatus**

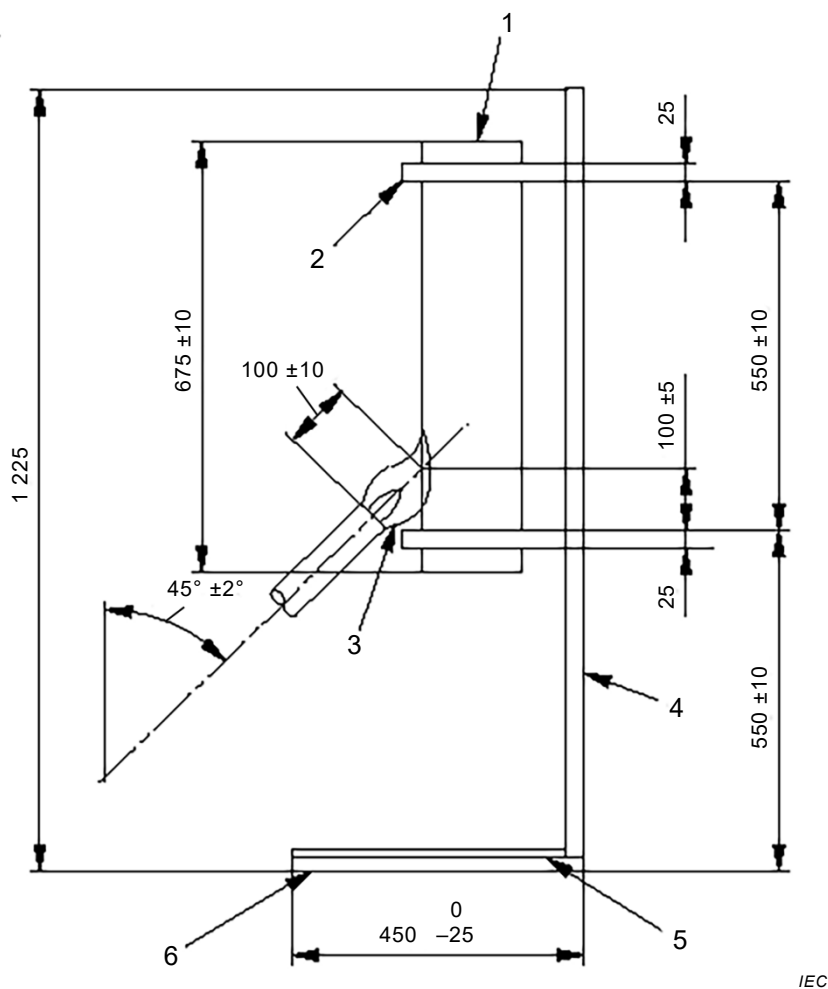

IEC

**Key**

- 1 sample centrally located in the horizontal plane
- 2 clamp
- 3 flame
- 4 back face
- 5 wrapping tissue
- 6 white-wood board , thickness 10 mm, width =  $700^{+0}_{-25}$

This drawing is not intended to govern design except as regards the dimensions shown.

**Figure 3 – Arrangement for test for resistance to flame propagation**

Dimensions in millimetres

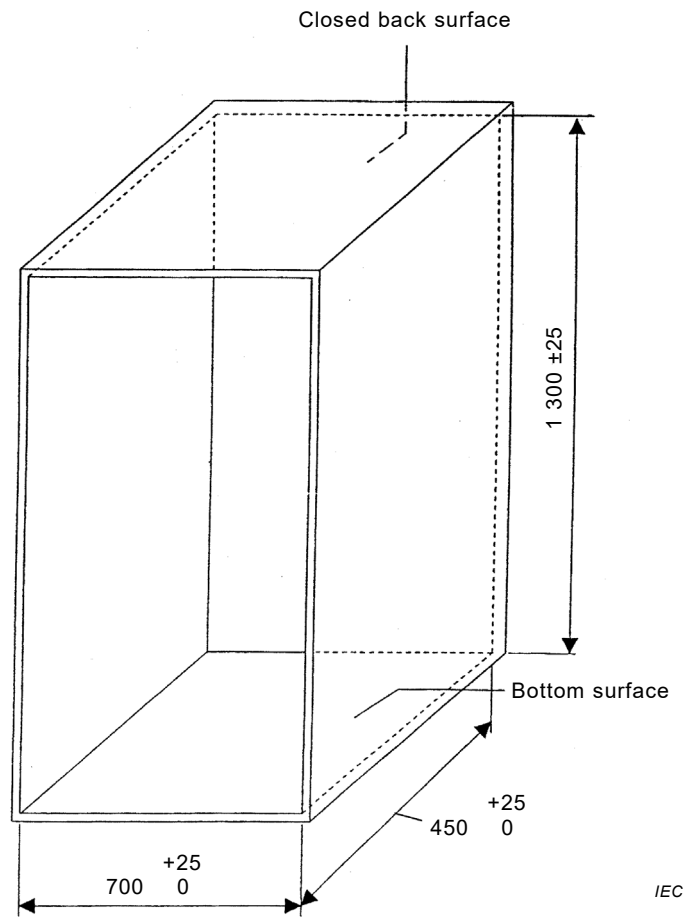

All dimensions are inside the enclosure.

Material: Metal.

This drawing is not intended to govern design except as regards the dimensions shown.

**Figure 4 – Enclosure for test for resistance to flame propagation**

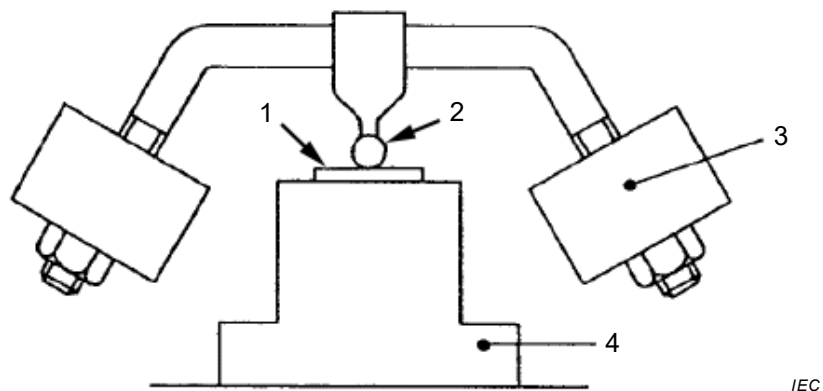

**Key**

- 1 test sample
- 2 ball
- 3 mass
- 4 support

**Figure 5 – Ball pressure test apparatus**

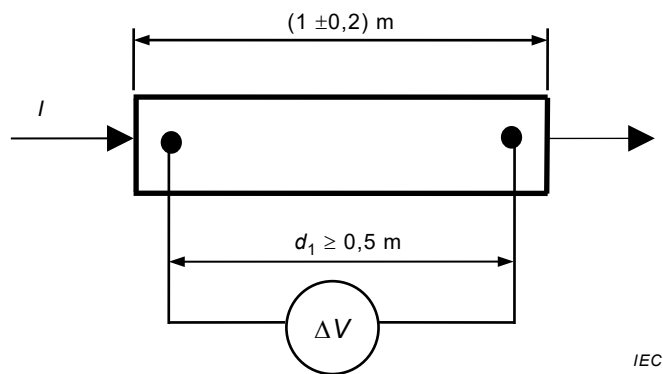

IEC

**Key**

$\Delta V$  voltage drop

$I$  current

$d_1$  distance between the two measurement points

**Figure 6a – Arrangement for trunking length or ducting length**

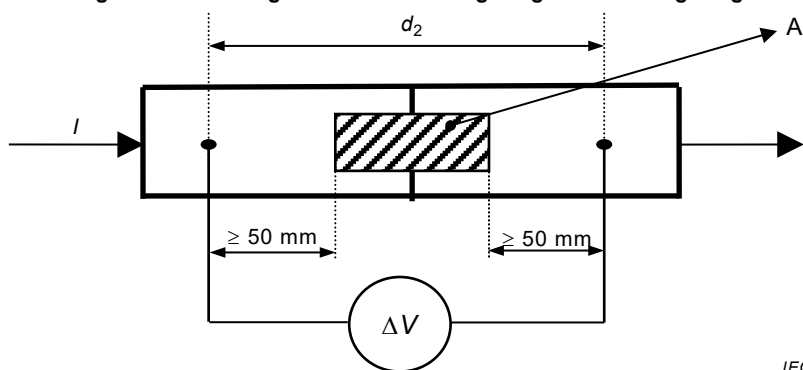

IEC

**Key**

A coupling area

$\Delta V$  voltage drop

$I$  current

$d_2$  distance between the two measurement points

**Figure 6b – Arrangement for a joint**

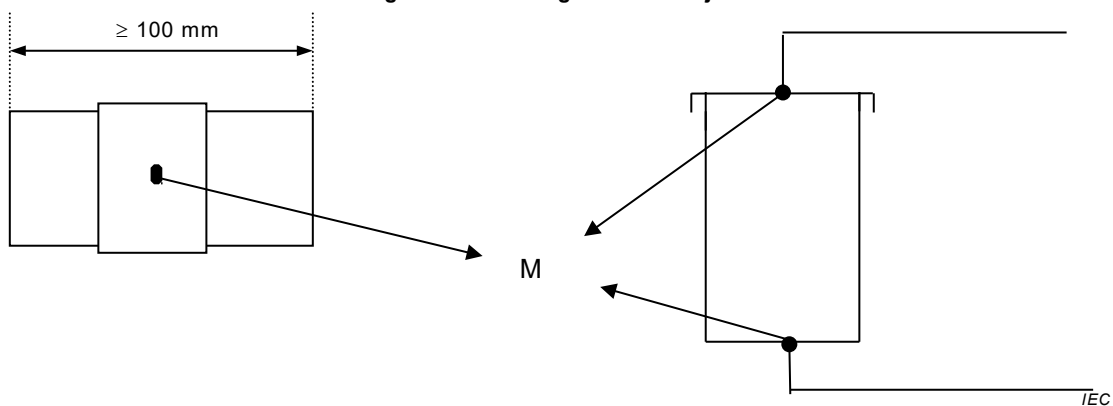

IEC

**Key**

M point of measurement at the centre of surface

**Figure 6c – Arrangement for connection between trunking base and access cover**

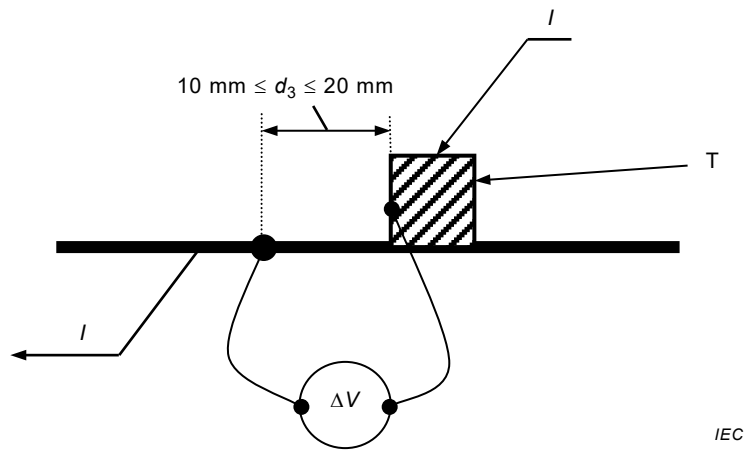

**Key**

- T terminal or termination
- $\Delta V$  voltage drop
- $I$  current
- $d_3$  distance between the two measurement points

**Figure 6d – Arrangement for earthing terminal or termination**

**Figure 6 – Electrical impedance tests arrangement**

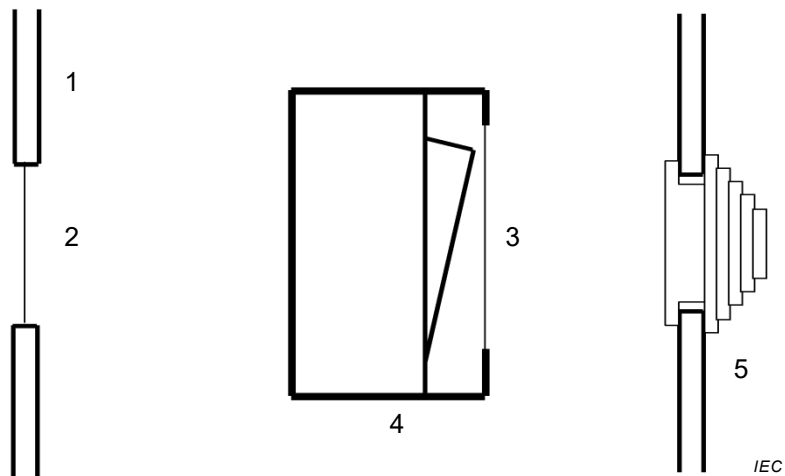

**Key**

- 1 wall of system component
- 2 entry membrane
- 3 protecting membrane
- 4 switch
- 5 grommet

**Figure 7 – Examples of membranes and grommets**

Dimensions in millimetres

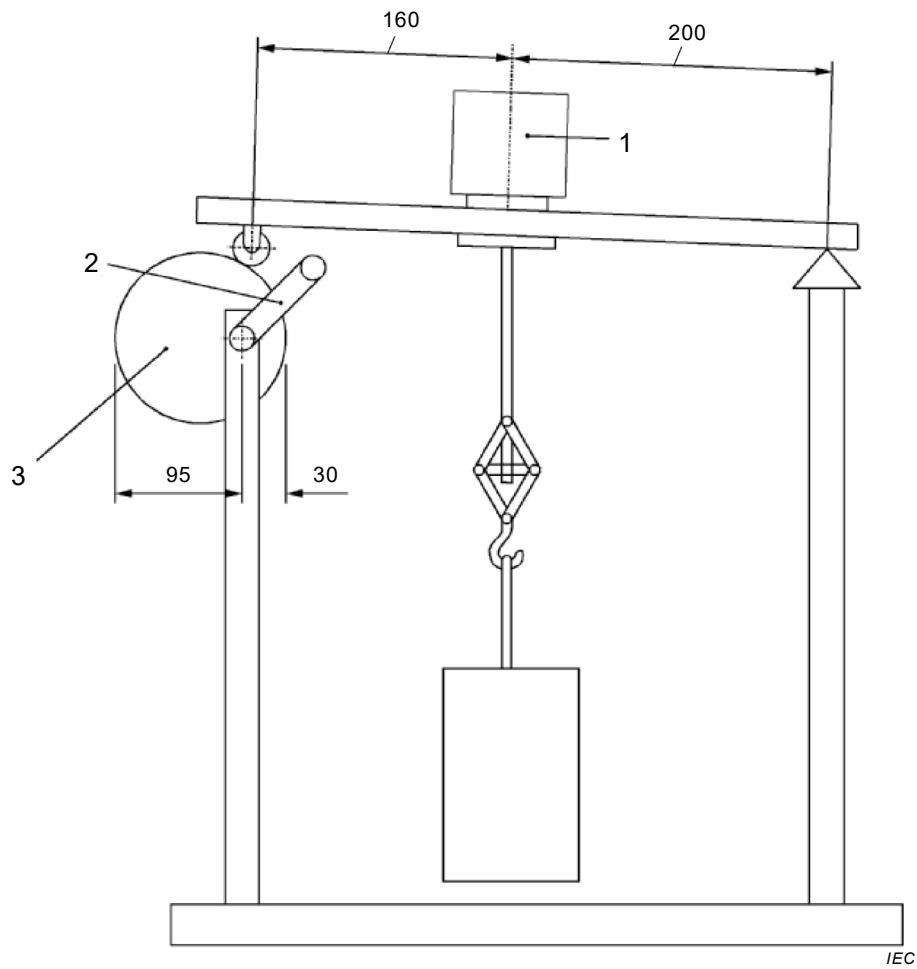

**Key**

- 1 cable anchorage
- 2 crank
- 3 eccentric

**Figure 8 – Typical apparatus for testing the resistance of cable anchorage to pull force**



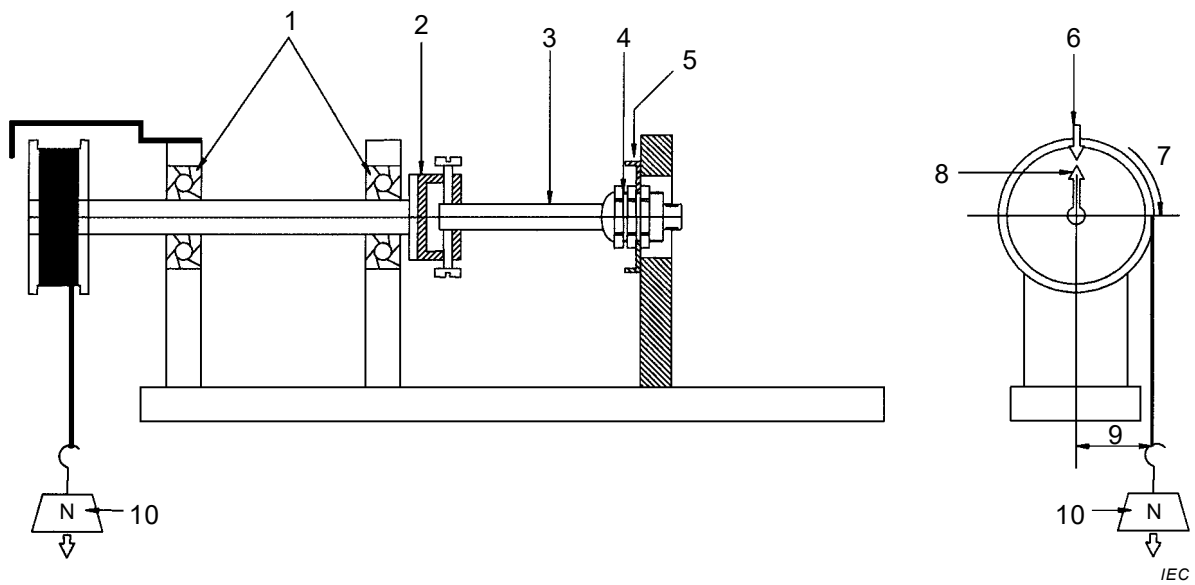

**Key**

- |   |   |    |                            |
|---|---|----|----------------------------|
| 1 | bearings enabling easy rotation         | 6  | fixed rotational indicator |
| 2 | device for securing test mandrel        | 7  | direction of rotation      |
| 3 | test mandrel                            | 8  | rotating indicator         |
| 4 | sample                                  | 9  | radius                     |
| 5 | sample securing plate (interchangeable) | 10 | load                       |

**Figure 9 – Typical apparatus for testing the resistance of cable anchorage to twist force**

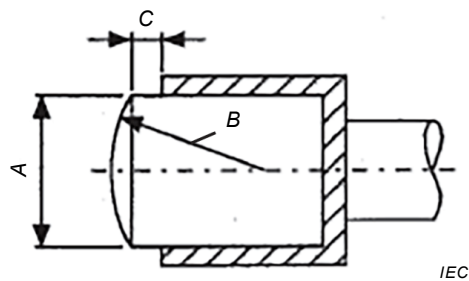

**Key**

- |   |                                      |                 |
|---|--------------------------------------|-----------------|
| A | diameter of the piston               | $(20 \pm 1)$ mm |
| B | radius of the piston head            | $(20 \pm 1)$ mm |
| C | gap between piston head and cylinder | $(2 + 1-0)$ mm  |

**Figure 10 – Piston for durability of marking test**

**Annex A**  
(informative)

**Types of cable trunking systems (CTS)  
and cable ducting systems (CDS)**

Types of CTS and CDS are given in Table A.1, Table A.2 and Table A.3.

**Table A.1 – Types of CTS and CDS for wall and ceiling installation**

No. on Figure 1 within circular border	Type	For	Mounting
1, 7, 11, 12, 13, 14, 15	CTS	Insulated conductors, cables	Surface on wall and ceiling, on walls mounted horizontally or vertically, on ceiling suspended
5	CTS	Insulated conductors, cables, apparatus (switches, socket outlets, circuit-breakers, etc.)	Surface on wall and ceiling, on walls mounted horizontally or vertically
3, 9	CTS	Insulated conductors, cables	Flush in wall and ceiling, in walls mounted horizontally or vertically
Not shown	CTS	Insulated conductors, cables, apparatus (switches, socket outlets, circuit-breakers, etc.)	Flush in wall and ceiling, in walls mounted horizontally or vertically
6	Skirting CTS	Insulated conductors, cables	Surface on wall and ceiling
Not shown	Skirting CTS	Insulated conductors, cables, apparatus (switches, socket outlets, circuit-breakers, etc.)	Surface on wall and ceiling
2, 8, 10	CDS	Insulated conductors, cables	Surface on wall and ceiling, on walls mounted horizontally or vertically, on ceiling suspended
4	CDS	Insulated conductors, cables	Embedded in wall and ceiling, in walls mounted horizontally or vertically

**Table A.2 – Types of CTS and CDS for floor installation**

No. on Figure 1 within square border	Type	For	Mounting
1	CTS	Insulated conductors, cables	Flush in floor
4, 6	CTS	Insulated conductors, cables	Surface on floor
5	CTS	Insulated conductors, cables	False floor
2	CDS	Insulated conductors, cables	Flush in floor
3	CDS	Insulated conductors, cables	Embedded in floor
7	Service unit	Apparatus	Flush in floor
8	Service unit	Apparatus	Surface on floor

**Table A.3 – Types of CTS and CDS for installation  
between two opposite surfaces**

No. on Figure 1 within triangular border	Type	For	Mounting
1	Service poles	Insulated conductors, cables, apparatus (switches, socket outlets, circuit-breakers, etc.)	Between floor and ceiling

**Annex B**  
(normative)

**CTS/CDS IK code**

The manufacturer may declare the CTS/CDS IK code according to IEC 62262 under the following conditions.

The declared code shall be IK04 at the minimum.

The test shall be carried out at ambient temperature using pendulum hammer

Before the test, non-metallic system components and composite system components are aged at the temperature declared according to Table 3 with a tolerance of  $\pm 2$  °C for 168 h continuously.

The conditions for mounting, assembling and positioning the samples, the number of impacts and their points of application together with the test compliance are described in the appropriate IEC 61084-2 part, in the impact test for installation and application.

## Bibliography

- [1] IEC 60050-195:1998, *International Electrotechnical Vocabulary – Part 195: Earthing and protection against electric shock*
  - [2] IEC 60050-441:1984, *International Electrotechnical Vocabulary – Switchgear, controlgear and fuses*
  - [3] IEC 60050-826:2004, *International Electrotechnical Vocabulary – Part 826: Electrical installations*
  - [4] IEC 60364-5-54:2011, *Low-voltage electrical installations – Part 5-54: Selection and erection of electrical equipment – Earthing arrangements and protective conductors*
  - [5] IEC 62262:2002, *Degrees of protection provided by enclosures for electrical equipment against external mechanical impacts (IK code)*
-



(Continued from second cover)

The Committee has reviewed the provisions of the following international standards referred in this adopted standard and decided that they are acceptable for use in conjunction with this standard.

<i>International Standard</i>	<i>Title</i>
IEC 60417	Graphical symbols for use on equipment
IEC 60695-11-2 : 2013	Fire hazard testing — Part 11-2: Test flames — 1 kW pre-mixed flame — Apparatus, confirmatory test arrangement and guidance

For the purpose of deciding whether a particular requirement of this standard is complied with, the final value, observed or calculated expressing the result of a test, shall be rounded off in accordance with IS 2 : 2022 'Rules for rounding off numerical values (*second revision*)'. The number of significant places retained in the rounded off value should be the same as that of the specified value in this standard.

## Bureau of Indian Standards

BIS is a statutory institution established under the *Bureau of Indian Standards Act, 2016* to promote harmonious development of the activities of standardization, marking and quality certification of goods and attending to connected matters in the country.

### Copyright

BIS has the copyright of all its publications. No part of these publications may be reproduced in any form without the prior permission in writing of BIS. This does not preclude the free use, in the course of implementing the standard, of necessary details, such as symbols and sizes, type or grade designations. Enquiries relating to copyright be addressed to the Head (Publication & Sales), BIS.

### Review of Indian Standards

Amendments are issued to standards as the need arises on the basis of comments. Standards are also reviewed periodically; a standard along with amendments is reaffirmed when such review indicates that no changes are needed; if the review indicates that changes are needed, it is taken up for revision. Users of Indian Standards should ascertain that they are in possession of the latest amendments or edition by referring to the website-[www.bis.gov.in](http://www.bis.gov.in) or [www.standardsbis.in](http://www.standardsbis.in).

This Indian Standard has been developed from Doc No.: ETD 14 (21091).

### Amendments Issued Since Publication

Amend No.	Date of Issue	Text Affected

## BUREAU OF INDIAN STANDARDS

### Headquarters:

Manak Bhavan, 9 Bahadur Shah Zafar Marg, New Delhi 110002

Telephones: 2323 0131, 2323 3375, 2323 9402

Website: [www.bis.gov.in](http://www.bis.gov.in)

### Regional Offices:

	Telephones
Central : 601/A, Konnectus Tower -1, 6 <sup>th</sup> Floor, DMRC Building, Bhavbhuti Marg, New Delhi 110002	{ 2323 7617
Eastern : 8 <sup>th</sup> Floor, Plot No 7/7 & 7/8, CP Block, Sector V, Salt Lake, Kolkata, West Bengal 700091	{ 2367 0012 2320 9474
Northern : Plot No. 4-A, Sector 27-B, Madhya Marg, Chandigarh 160019	{ 265 9930
Southern : C.I.T. Campus, IV Cross Road, Taramani, Chennai 600113	{ 2254 1442 2254 1216
Western : Plot No. E-9, Road No.-8, MIDC, Andheri (East), Mumbai 400093	{ 2821 8093

**Branches :** AHMEDABAD. BENGALURU. BHOPAL. BHUBANESHWAR. CHANDIGARH. CHENNAI. COIMBATORE. DEHRADUN. DELHI. FARIDABAD. GHAZIABAD. GUWAHATI. HIMACHAL PRADESH. HUBLI. HYDERABAD. JAIPUR. JAMMU & KASHMIR. JAMSHEDPUR. KOCHI. KOLKATA. LUCKNOW. MADURAI. MUMBAI. NAGPUR. NOIDA. PANIPAT. PATNA. PUNE. RAIPUR. RAJKOT. SURAT. VISAKHAPATNAM.