प्लास्टिक— परीक्षण की पद्धतियाँ

भाग 4 रिओलोजिकल गुणधर्म

अनुभाग 1 थर्मोप्लास्टिक के गलन पिंड प्रवाह दर (एमएफ़आर)
और गलन परिमाण प्रवाह दर

उपभाग 2 समय तापमान इतिहास और नमी के प्रति संवेदनशील
सामग्री के लिए प्रणाली

(पहला पुनरीक्षण)

Plastics — Methods of Testing

Part 4 Rheological Properties

Section 1 Determination of Melt Mass-Flow Rate (MFR) and the
Melt Volume-Flow Rate (MVR) of Thermoplastics

Subsection 2 Method for materials sensitive to time-temperature
history and/or moisture

(*First Revision*)

ICS 83.080.20

© BIS 2018



भारतीय मानक ब्यूरो

BUREAU OF INDIAN STANDARDS

मानक भवन, 9 बहादुरशाह ज़फर मार्ग, नई दिल्ली-110002

MANAK BHAVAN, 9 BAHADUR SHAH ZAFAR MARG

NEW DELHI-110002

www.bis.org.in www.standardsbis.in

NATIONAL FOREWORD

This Indian Standard (Part 4/Sec 1/Sub Section 2) (First Revision) which is identical with ISO 1133-2 : 2011 'Plastics - Determination of melt mass-flow rate (MFR) and the melt volume-flow rate (MVR) of thermoplastics- Part 2 Method for materials sensitive to time-temperature history and/or moisture' issued by the International Organization for Standardization (ISO) was adopted by the Bureau of Indian Standards on the recommendation of the Methods of Sampling and test for Plastics Sectional Committee and approval of the Petroleum, Coal and Related Products Division Council.

The text of ISO Standard has been approved as suitable for publication as an Indian Standard without deviations. Certain conventions are, however, not identical to those used in Indian Standards. Attention is particularly drawn to the following:

- a) Wherever the words 'International Standard' appear referring to this standard, they should be read as 'Indian Standard'.
- b) Comma (,) has been used as a decimal marker while in Indian Standards, the current practice is to use a point (.) as the decimal marker.

In this adopted standard, reference appears to certain International Standards for which Indian Standards also exist. The corresponding Indian Standards which are to be substituted in their respective places are listed below along with their degree of equivalence for the edition indicated:

<i>International Standard</i>	<i>Corresponding Indian Standard</i>	<i>Degree of Equivalence</i>
ISO 472 Plastics — Vocabulary	IS 2828 : 2001 Plastics — Vocabulary (<i>first revision</i>)	Identical
ISO 1133-1 : 2011 Plastics — Determination of the melt mass-flow rate (MFR) and melt volume-flow rate (MVR) of thermoplastics — Part 1: Standard method	IS 13360 (Part 4/Sec 1/Subsec 1) : 2018 Plastics — Methods of testing Part 4 Rheological properties, Section 1 Determination of melt mass-flow rate (MFR) and the melt volume-flow rate (MVR) of thermoplastics, Subsection 1 Standard method (<i>first revision</i>)	do

The technical committee has reviewed the provisions of the following International Standard referred in this adopted standard and has decided that it is acceptable for use in conjunction with this standard:

<i>International Standard</i>	<i>Title</i>
ISO 15512	Plastics — Determination of water content

For tropical countries like India, the standard temperature and the relative humidity shall be taken as $27 \pm 2^\circ\text{C}$ and 65 ± 5 percent respectively.

In reporting the results of a test or analysis made in accordance with this standard, if the final value, observed or calculated, is to be rounded off, it shall be done in accordance with IS 2 : 1960 'Rules for rounding off numerical values (*revised*)'.

Indian Standard

PLASTICS — METHODS OF TESTING

PART 4 RHEOLOGICAL PROPERTIES

Section 1 Determination of Melt Mass-Flow Rate (MFR) and the Melt Volume-Flow Rate (MVR) of Thermoplastics

Subsection 2 Method for Materials Sensitive to Time-Temperature History and/or Moisture

(*First Revision*)

WARNING — Persons using this document should be familiar with normal laboratory practice, if applicable. This document does not purport to address all of the safety problems, if any, associated with its use. It is the responsibility of the user to establish appropriate safety and health practices and to ensure compliance with any regulatory requirements.

IMPORTANT — The equipment shall meet the requirements specified in this document and the measurements shall be carried out under specified conditions of temperature and load with special attention being paid to sample pre-treatment, strictly following the procedure prescribed in this document and in any applicable material standard.

1 Scope

This part of ISO 1133 specifies a procedure for the determination of the melt volume-flow rate (MVR) and melt mass-flow rate (MFR) of thermoplastic materials that exhibit a high rheological sensitivity to the time-temperature history experienced by the sample during the test and/or to moisture.

NOTE 1 Some grades of materials affected by hydrolysis are of, for example, poly(ethylene terephthalate) (PET), poly(butylene terephthalate) (PBT), poly(ethylene naphthalate) (PEN), other polyester types and polyamides; and by cross-linking are of, for example, thermoplastic elastomers (TPE) and thermoplastic vulcanizates (TPV). It is possible that this method will also be suitable for use with other materials.

It is possible that this method will not be appropriate for materials whose rheological behaviour is extremely affected during testing (see Note 2).

NOTE 2 For materials where the coefficient of variation of the MFR or MVR results is found to be higher than the precision mentioned in ISO 1133-1, the viscosity number in dilute solution (ISO 307, ISO 1628) can be more appropriate for characterization purposes.

NOTE 3 Minor deviations from the equipment requirements, procedure and/or sample handling can result in considerable loss of reproducibility, repeatability and accuracy of the measurement. MVR results determined on different materials, indicating the repeatability of the test method of this part of ISO 1133 when measured under ideal measurement conditions, are reported in Annex B.

MFR values can be determined by calculation from MVR measurements provided the melt density at the test temperature and pressure is known, or by measurement using a cutting device provided that the accuracy of the measurement is at least the same as that of the MVR measurement.

NOTE 4 The density of the melt is required at the test temperature and pressure. In practice, the pressure is low and values obtained at the test temperature and ambient pressure suffice.

The primary difference between this part of ISO 1133 and ISO 1133-1 is that this part of ISO 1133 specifies tighter tolerances on the temperature in the cylinder and on the time duration over which the material is subjected to that temperature. Thus the time-temperature history of the material is more tightly controlled and consequently, for materials that are likely to be affected by exposure to elevated temperatures, the variability of test results is reduced compared with whether the specifications of ISO 1133-1 were used.

This part of ISO 1133 also provides information for preparation and handling of moisture sensitive materials that again are critical to obtaining repeatable, reproducible and accurate data.

The test conditions for measurement of the MVR and MFR are often specified in the material standard. However, for those materials where there are no test conditions specified in the material standard, it is necessary for the test conditions to be agreed between the interested parties.

2 Normative references

The following referenced documents are indispensable for the application of this document. For dated references, only the edition cited applies. For undated references, the latest edition of the referenced document (including any amendments) applies.

ISO 472, *Plastics — Vocabulary*

ISO 1133-1, *Plastics — Determination of the melt mass-flow rate (MFR) and melt volume-flow rate (MVR) of thermoplastics — Part 1: Standard method*

ISO 15512, *Plastics — Determination of water content*

3 Terms and definitions

For the purposes of this document, the terms and definitions given in ISO 472 and ISO 1133-1 apply.

4 Principle

The melt volume-flow rate (MVR) and melt mass-flow rate (MFR) are determined by extruding molten material from the cylinder of a plastometer through a die of specified length and diameter under preset conditions of temperature and load.

For measurement of MFR, timed segments of the extrudate are weighed and the extrusion rate is calculated in grams per 10 min and recorded.

For measurement of MVR, the distance that the piston moves in a specified time or the time required for the piston to move a specified distance is determined to generate extrusion rate data in cubic centimetres per 10 min.

MVR can be converted to MFR, or vice versa, if the density of the material at the test temperature is known.

In comparison with ISO 1133-1, the permitted tolerances on the temperature, time line, sample amount and pre-treatment are tighter, resulting in more accurate measurements for time-temperature and moisture sensitive materials.

5 Apparatus

5.1 Extrusion plastometer

5.1.1 General. For the purposes of this part of ISO 1133, the apparatus specified in ISO 1133-1 and the following specifications apply. Where the following specifications differ from those presented in ISO 1133-1, the following specifications shall be used.

5.1.2 Cylinder. See ISO 1133-1.

5.1.3 Piston. See ISO 1133-1.

5.1.4 Temperature-control system. For all cylinder temperatures used, the absolute temperature shall be such that between 0 mm and 70 mm above the die surface the maximum deviation from the required test temperature does not exceed ± 1 °C.

For all cylinder temperatures used, the relative distribution of the temperature shall be such that between 0 mm and 70 mm above the die surface the maximum deviation does not exceed $\pm 0,3$ °C with distance and with time throughout the test.

The temperature-control system shall allow the test temperature to be set in steps of 0,1 °C or less.

NOTE 1 Tight tolerances on temperature are considered necessary as the time-temperature history of the material during the test can have a significant effect on measured rheological behaviour. It is therefore necessary to specify these conditions more tightly than in ISO 1133-1 in order to achieve measurement precision comparable with that obtained using ISO 1133-1 with stable materials.

NOTE 2 The temperature can be measured and controlled with temperature measuring devices embedded in the wall of the cylinder. If the apparatus is equipped in this way, it is possible that the temperature is not exactly the same as that in the melt, but the temperature-control system can be calibrated to read the in melt temperature.

5.1.5 Die. See ISO 1133-1.

The standard die of $(8,000 \pm 0,025)$ mm in length, $(2,095 \pm 0,005)$ mm in diameter, as specified in ISO 1133-1, shall be used unless stated otherwise in the relevant materials standard or agreed by the interested parties.

When using a standard die for testing low melt-viscosity materials such as bottle-grade PET, the material may extrude through the die during charging, and it might also be difficult to ensure void-free extrudate resulting in reduced precision and accuracy. In these cases the use of the half size die, specified in ISO 1133-1, is recommended (8.1).

5.1.6 Means of setting and maintaining the cylinder truly vertical. See ISO 1133-1.

5.1.7 Load. See ISO 1133-1.

5.2 Accessory equipment

5.2.1 General. For the purposes of this part of ISO 1133, the accessory equipment given in ISO 1133-1 and the following equipment apply.

5.2.2 Packing rod. See ISO 1133-1.

5.2.3 Cleaning equipment. See ISO 1133-1.

5.2.3.1 Go/no-go gauge. See ISO 1133-1.

5.2.3.2 Temperature verification device. See ISO 1133-1.

The temperature verification device shall have sufficient accuracy and precision to enable verification of the MVR/MFR instrument to the temperature tolerances specified in 5.1.4.

The equipment used to calibrate the temperature without material in the cylinder differs from that specified in ISO 1133-1, since verifying the temperature at 10 mm intervals from 0 mm to 70 mm above the standard die is required for this test method (Annex A; Note 5).

5.2.3.3 Die plug. See ISO 1133-1.

5.2.3.4 Piston/weight support. See ISO 1133-1.

5.2.3.5 Preforming device. See ISO 1133-1.

5.2.3.6 Drying equipment. Vacuum ovens or hot air dryers used to remove moisture from the samples (6.2) where required by the material standard.

The use of vacuum ovens is preferred as this should result in exposing the materials to be dried to shorter times at lower temperatures, thereby reducing the magnitude of any changes occurring to the rheological properties of the materials due, for example, to hydrolysis.

5.2.3.7 Moisture content determination. The moisture content shall be determined according to ISO 15512, unless otherwise specified by the material standard.

5.2.4 Equipment for melt mass flow rate determination (Procedure A). See ISO 1133-1.

If the instrument is not equipped with an automatic cut-off device, manual cutting may be used if the accuracy of the measurement is at least the same as the MVR measurement.

5.2.5 Equipment for melt volume flow rate determination (Procedure B). See ISO 1133-1.

6 Test sample

6.1 Sample form

See ISO 1133-1.

6.2 Sample pre-treatment and storage

The test sample shall be treated, e.g. dried, prior to testing in accordance with the appropriate material specification standard. When a preformed solid charge of powder or flakes (ISO 1133-1) is used as the test sample, the material shall be dried prior to preforming. If the sample pre-treatment is not specified in the relevant material standard, it shall be agreed between the interested parties.

For materials that are sensitive to moisture, the moisture content shall be such that its effect on the MVR or MFR of the material under the test conditions used is minimized as far as possible. The material shall be handled both before and after drying in such a way that absorption of moisture is prevented or minimized, e.g. by preventing moisture transfer caused by skin-sample contact or uptake from the atmosphere.

Immediately after drying, the material shall be transferred into a dry, preferably hot, moisture-proof container preventing moisture uptake. Then the material shall be allowed to cool down to ambient temperature and the test shall be carried out within 4 h after transfer to the dry container or within 2 d when stored in a desiccator containing a drying agent, unless otherwise specified in the relevant material standard or agreed between the interested parties.

All preformed charges, after removing from the charge forming instrument (ISO 1133-1) and before testing, shall be handled and stored in the same manner to improve repeatability of measurements, except that preformed charges may need to be tested without cooling to avoid distortion of the charge which would prohibit its insertion into the MVR/MFR cylinder.

For comparison of results, e.g. with other laboratories, the material should be cooled down in order to prevent differences in temperature history, or the procedure should be agreed between the interested parties. However, for production control or practical purposes it might be preferable to charge the MVR equipment with the material directly from the oven.

The material should not be allowed to cool down to ambient temperature inside a (vacuum) oven, as due to the very long cooling down time the time-temperature history of the sample is quite different compared with cooling down in a container and may have a significant influence on the results.

NOTE The effect of moisture content on the rheological behaviour of the material can be determined by carrying out repeat experiments on samples with different moisture contents.

7 Temperature verification, cleaning and maintenance of the apparatus

7.1 Verification of the temperature-control system

7.1.1 Verification procedure

When verifying the temperature variation with position and time, set the temperature-control system of the MVR/MFR equipment to the required temperature and wait at least the prescribed time mentioned in the equipment manual until the cylinder remains at the set temperature as indicated by the instrument control thermometer.

Verify the temperature variation in the cylinder at (10 ± 1) mm intervals from 0 mm above the top of the standard die up to and including (70 ± 1) mm above the top of the standard die using a calibrated temperature-measuring device. The temperature variation shall be measured at each of the 10 mm intervals by recording, at each position, the temperature at 1 min intervals until 10 min after the first stable temperature reading.

A method for performing the verification is presented in Annex A.

NOTE The time until the temperature reading becomes stable after immersing or repositioning the temperature measuring device in the cylinder depends on the equipment used. Information on the response time of the temperature-measuring device may be available from the device supplier.

7.1.2 Material used during temperature verification

See ISO 1133-1 and Annex A.

7.2 Cleaning the apparatus

See ISO 1133-1.

7.3 Vertical alignment of the instrument

See ISO 1133-1.

8 Procedural set-up

8.1 General

The automatic measurement of distance and time for the piston movement (ISO 1133-1, procedure B) is preferred as it can result in better repeatability than the MFR method (ISO 1133-1, procedure A) for testing materials that exhibit a high rheological sensitivity to the time-temperature history and/or moisture.

If the MVR value is higher than $40 \text{ cm}^3/10 \text{ min}$, use of the half size die may be considered (5.1.5).

MFR values can be determined from MVR values, or vice versa, given the density of the polymer at the test temperature (see ISO 1133-1).

NOTE The density of the melt is required at the test temperature and pressure. In practice, the pressure is low and values obtained at the test temperature and ambient pressure suffice.

8.2 Selection of temperature and load

Consult the relevant material standard for the appropriate test conditions.

If no material standard exists or if no MVR or MFR test conditions are specified in the material standard, the test temperature and load shall be agreed between the interested parties, based on knowledge of the melting point of the material or its processing conditions recommended by the manufacturer. See ISO 1133-1:2011, Table A.1.

NOTE In general, the test conditions for determination of MVR and MFR values are specified in the material standards. Test conditions for the measurement of the MVR and MFR of materials whose rheological behaviour is affected by hydrolysis and condensation during the measurement are in many cases not yet mentioned in the material standards. Standards for these materials are likely to be developed and revised in the future.

8.3 Cleaning

WARNING — The operating conditions may entail partial decomposition of the material under test or any material used to clean the instrument, or cause them to release dangerous volatile substances, as well as presenting the risk of burns. It is the responsibility of the user of this document to establish appropriate safety and health practices and determine the applicability of regulatory limitations prior to use.

See ISO 1133-1.

The cylinder and all components, including the die, shall be cleaned thoroughly between each test.

IMPORTANT — In testing hygroscopic materials, thorough cleaning is very important. The presence of contaminants or their thermolysis products is a major problem as this may accelerate hydrolytic degradation of hygroscopic materials.

8.4 Selection of sample mass and charging the cylinder

Select the sample amount according to the anticipated MVR or MFR. The MVR or MFR shall preferably be higher than 10 cm³/10 min and lower than 40 cm³/10 min. For comparison of materials with the same MVR or MFR, the sample volumes shall be within ±0,5 cm³ of each other. See Table 1.

Samples shall not be touched by the operator, to avoid moisture contamination via skin contact, and exposure to the atmosphere shall be minimized. Sample handling, including the opening of the sample storage container and transfer to and charging of the cylinder, shall be minimized. Sample handling shall not be carried out for longer than 1 min before charging the material in order to prevent moisture take-up.

The sample amount shall be such that in all cases the measurement starts between 5,5 min and 6,0 min after completing the charging of the material.

Table 1 — Guidelines for sample amount

Expected MVR, cm ³ /10 min Expected MFR, g/10 min	Compacted sample volume in the cylinder, cm ³
10 to 20	4 to 5
20 to 30	5 to 6
30 to 40	6 to 7

NOTE 1 For many time-temperature history sensitive materials, the MVR determination is influenced by the volume of material in the cylinder. Use of the same sample volume for the analysis of materials of similar MVR or MFR reduces variability in the data. The sample amount can be measured, for example, by a sample cup of the required size or equated to a mass amount equivalent to the volume.

It is recommended to purge the barrel with dry nitrogen prior to inserting the sample and to maintain a nitrogen atmosphere during the test in order to minimize oxidative degradation and prevent moisture uptake that may influence the results.

Charge the cylinder with the selected amount of the sample. During charging, compress the material with the packing rod using hand pressure but avoiding large variations in the packing pressure as far as possible. For materials susceptible to oxidative or hydrolytic degradation, ensure the charge is as free from air as possible. Complete the charging process within 0,5 min to 1 min. Immediately put the piston in the cylinder. The preheat time of 5 min begins immediately after charging of the cylinder has been completed.

NOTE 2 Variations in the packing pressure used to compress the material in the cylinder can cause poor repeatability of results.

NOTE 3 For some materials a shorter preheating time can be required to prevent degradation and for high melting point, high T_g , low thermal conductivity materials, a longer time can be needed to obtain repeatable results.

The piston may be unloaded or underloaded during preheating for materials with higher flow rate. If the MVR of the material is high, the loss of sample during preheating is appreciable. In this case, use an unloaded piston or one carrying a smaller load during the preheating period. In the case of very high melt flow rates, a weight support should be used and a die plug may be necessary to prevent drooling of molten material from the end of die.

During the preheat time, check that the temperature has returned to the selected value.

9 Procedure

9.1 Selection of temperature and load

See 8.2.

9.2 Minimum piston displacement distance

The piston shall travel a specified distance of between 20 mm and 30 mm.

9.3 Timer device

See ISO 1133-1.

9.4 Preparation for the test

See Clause 8.

9.5 Measurement

9.5.1 General

Apply the selected load on the piston 5 min after completing the charging of the cylinder with the test sample. If the die plug is used and less than the desired load is on the piston, add the desired load and allow the material to stabilize for a few seconds before removing the die plug. If a weight support and die plug are both used, remove the weight support first. Allow the loaded piston to descend under gravity and make sure that a bubble-free filament is extruded. Forced purging of the sample, done either manually or by using extra weights, before commencement of the test shall be avoided.

The pre-run time, the time between applying the load and the start of the measurement, shall be between 0,5 min and 1 min.

The measurement shall start between 5,5 min and 6,0 min after completing the charging of the material.

To minimize the risk of burns from hot material coming out of the die rapidly, heat resistant gloves should be worn during the removal of the die plug.

9.5.2 Displacement measurement method (MVR)

The test shall start when the lower reference mark has reached the top edge of the cylinder.

Measure the time taken for the piston to travel a specified distance of between 20 mm and 30 mm. The test shall stop before or when the second mark reaches the top of the cylinder.

NOTE Variations in the charge time, the preheating time and the pre-run time can cause poor repeatability of results.

9.5.3 Mass measurement method (MFR)

When the lower reference mark has reached the top edge of the cylinder, start the timer and simultaneously cut off the extrudate, preferably using an automatic cutting device, and discard (5.2.2). If manual cutting is used, this shall be stated in the test report.

Collect successive cut-offs in order to measure the extrusion rate for a given time-interval. Depending on the MFR, choose a time-interval so that the length of a single cut-off is not less than 10 mm.

Stop cutting when the upper mark on the piston stem reaches the top edge of the cylinder. Discard all cut-offs containing visible air bubbles. After cooling, weigh individually, to the nearest 1 mg, the remaining cut-offs, preferably three or more, and calculate their average mass.

If the difference between the maximum and the minimum values of the individual weighings exceeds 10 % of the average, discard the results and repeat the test on a fresh portion of the sample.

The difference between the maximum and the minimum values of the individual weighings should preferably not exceed three times the standard deviation calculated from the individual MFR data points obtained from a single cylinder charge.

It is recommended that the cut-offs be weighed in order of extrusion. If a continuous change in mass is observed, this shall be reported as unusual behaviour (see Clause 12).

9.6 Expression of results

See ISO 1133-1.

10 Flow rate ratio (FRR)

See ISO 1133-1.

11 Precision

The precision of the method is not known because interlaboratory data are not available.

The results of MVR measurements carried out on several materials under ideal measurement conditions, using the method specified in this part of ISO 1133 and carried out by one operator in one laboratory using one MVR apparatus are reported in Annex B. The MVR values reported in Annex B are average values obtained from five to nine measurements.

Consideration shall be given to the factors leading to a decrease in repeatability and may influence the magnitude of the measured values. Such factors include the following.

- a) Melt-rheological properties affected by the moisture-content; the use of appropriate drying processes and conditions and handling practices is necessary to reduce the variability.

- b) Hydrolytic degradation of hygroscopic materials during the preheating or test period causes the melt flow rate to change; the use of appropriate drying processes and conditions and handling practices is necessary to reduce the variability.
- c) The presence of contaminants or their thermolysis products may accelerate degradation of the sample. Once hydrolytic degradation occurs, the degradation is autocatalytic and the melt-viscosity decreases. The use of appropriate cleaning processes is necessary to reduce the variability.

12 Test report

See ISO 1133-1 including:

- a) reference to this part of ISO 1133 (ISO 1133-2:2011);
- b) a report of whether manual or automated cut-off is used for MFR measurements.

Annex A (informative)

Verification of temperature in the cylinder

Install the temperature measuring device in the empty and cold MVR/MFR cylinder with the sensor tip on the top of the standard die. Put a mark on the temperature measuring device at the top of the cylinder with a so-called permanent marker as shown in Figure A.1. The mark represents the measurement point “0 mm above the die”.

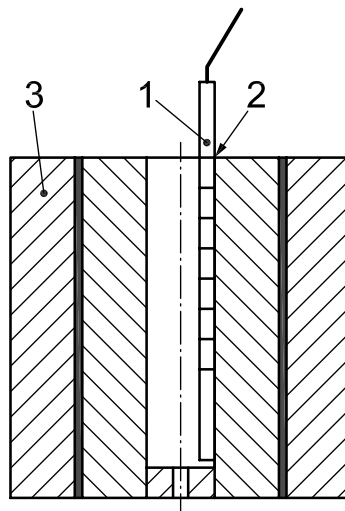

Key

- 1 temperature measuring device
- 2 mark
- 3 MVR/MFR cylinder

Figure A.1 — MVR/MFR cylinder

Remove the temperature measuring device from the cylinder. Starting from the mark 0 mm above the die, divide a length of (70 ± 1) mm towards the tip of the temperature measuring device in (10 ± 1) mm intervals using the marker, as shown in Figure A.2.

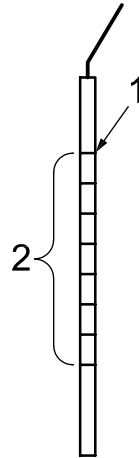

Key

- 1 0 mm above the die
- 2 marks

Figure A.2 — Temperature measuring device marking

Block the die exit by means of a die plug. To prevent burns from the heated cylinder and/or material, heat resistant gloves should be worn while installing or removing the die plug.

Set the temperature-control system of the MVR/MFR equipment to the required temperature and wait at least the prescribed time specified in the equipment manual until the cylinder reaches temperature equilibrium.

Charge the cylinder with material using the same filling technique as for a MVR/MFR determination (8.4). The quantity of the material shall be such that the cylinder is filled up to at least 100 mm above the top of the die.

NOTE 1 Polypropylene (PP) for a cylinder temperature up to 250 °C or polycarbonate (PC) for a temperature higher than 250 °C and up to approximately 320 °C have been found suitable.

The height of the filling can be checked with the piston. On touching the melt, the lower mark on the piston should be at least 40 mm above the top of the cylinder.

Introduce the temperature measuring device into the cylinder 5 min after completing the charging of the material and immerse it in the material therein until the first mark is at the same height as the top of the cylinder with the tip of the device at the wall as shown in Figure A.3. The tip of the temperature measuring device is then 70 mm above the top of the die.

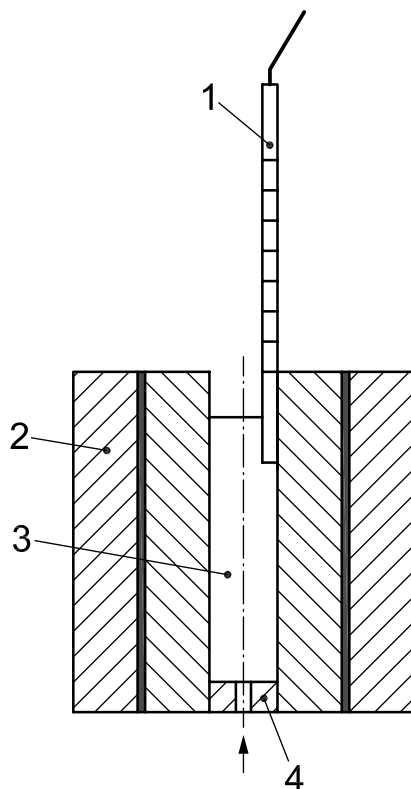

Key

- 1 marked temperature measuring device
- 2 MVR/MFR cylinder
- 3 material
- 4 die plug

Figure A.3 — Determination of the temperature profile of the MVR/MFR cylinder

Record the height of the temperature measuring device tip above the top of the die (70 mm) and the temperature reading when the temperature is stable. Determine the temperature variation with time by recording the temperature and time at 1 min intervals until 10 min after the first stable temperature reading is taken.

NOTE 2 The time until the temperature reading becomes stable after immersing or repositioning the temperature measuring device in the cylinder depends on the equipment used. Information on the response time of the temperature-measuring device may be available from the device supplier.

The temperature measuring device may act as a temperature sink due to the heat flow through its casing. The design of the temperature measuring device and material of construction should affect the measurement as little as possible.

Immerse the temperature measuring device 10 mm further into the material until the next mark is at the same height as the top of the cylinder. The tip of the temperature measuring device is then 60 mm above the die. Record the height of the temperature measuring device tip above the top of the die (60 mm) and the temperature reading when the temperature is stable. Determine the temperature variation with time by recording the temperature and time at 1 min intervals until 10 min after the first stable temperature reading is taken.

Measure the temperature at each following 10 mm interval along the length of the cylinder as described in the preceding. The last measurement point is with the tip of the temperature measuring device on the top of the die (0 mm).

If the material is not stable over the total time of the verification procedure and is considered to affect the verification or to be difficult to clean, the temperature stability of the cylinder with time shall be determined in stages, if necessary separately for each position in the cylinder.

NOTE 3 An alternative technique for the verification is to use a non-metallic piston equipped with temperature measuring devices at 10 mm intervals from 0 mm to 70 mm above the standard die, which can be inserted completely and is closely fitting in the bore without material present. A non-metallic piston equipped with a single temperature measuring device can similarly be used. The use of a non-metallic piston is aimed at reducing the disturbance to the temperature profile in the cylinder.

Annex B
 (informative)

Repeated MVR determinations on different materials carried out in line with this part of ISO 1133

The results reported in this annex were achieved using test conditions within the limits specified at the beginning of the development of this part of ISO 1133. The measurements were carried out by one operator within one laboratory using one MVR apparatus. The values do not represent the true repeatability of the method.

The MVR values reported are average values obtained from five to nine measurements.

Table B.1 — MVR measurements on different materials

Polyamide 6					
Material MVR-type	Moisture content, mg/kg (ppm)	Test parameters	MVR average, cm³/10 min	Standard deviation, cm³/10 min	Coefficient of variation, %
High	308	275 °C/5 kg/standard die	103	0,8	0,8
Medium	295	275 °C/5 kg/standard die	64,3	0,9	1,4
Low	412	275 °C/5 kg/standard die	34,0	0,5	1,5

Poly(butylene terephthalate)					
Material MVR-type	Moisture content, mg/kg (ppm)	Test parameters	MVR average, cm³/10 min	Standard deviation, cm³/10 min	Coefficient of variation, %
Very high	118	250 °C/2,16 kg/standard die	63,4	0,3	0,5
High	143	250 °C/2,16 kg/standard die	35,0	0,2	0,6
Medium	166	250 °C/2,16 kg/standard die	22,3	0,1	0,4
Low	83	250 °C/2,16 kg/standard die	2,4	0,2	8,2

Poly(butylene terephthalate)					
Material MVR-type	Moisture content, mg/kg (ppm)	Test parameters	MVR average, cm³/10 min	Standard deviation, cm³/10 min	Coefficient of variation, %
Very high	133	250 °C/5 kg/half size die	32,7	0,1	0,3
		250 °C/2,16 kg/half size die	13,5	0,1	0,4
		250 °C/5 kg/standard die	251	3	1,2
		250 °C/2,16 kg/standard die	106	3	2,8

Poly(ethylene terephthalate)					
Material MVR-type	Moisture content, mg/kg (ppm)	Test parameters	MVR average, cm ³ /10min	Standard deviation, cm ³ /10min	Coefficient of variation, %
Very high	45	280 °C/5 kg/half size die	36,1	0,1	0,3
High	44	280 °C/5 kg/half size die	15,9	0,2	1,3
Medium	26	280 °C/5 kg/half size die	10,5	0,1	1,0
Medium	37	280 °C/5 kg/half size die	6,6	0,1	1,2
Low	49	280 °C/5 kg/standard die	16,3	0,4	2,5
High (glass fibre 30 % mass fraction)	15	280 °C/5 kg/standard die	74,2	3,0	4,0

Polyether/ester					
Material MVR-type	Moisture content, mg/kg (ppm)	Test parameters	MVR average, cm ³ /10 min	Standard deviation, cm ³ /10 min	Coefficient of variation, %
Low	240	230 °C/10 kg/standard die	2,5	0,1	2,3
High	320	230 °C/2,16 kg/standard die	33,2	0,3	0,9

NOTE The testing reported here was carried out prior to the inclusion of melt flow rate test conditions in the relevant materials specification standards for the materials studied. The testing conditions of Table B.1 were applied for research and development purposes and are thus not necessarily compliant with the materials specification standards.

The improvements in repeatability and reproducibility that can be achieved by specifying tighter tolerances on the temperatures, time-line and sample amount, and sample conditioning, i.e. as in this part of ISO 1133 compared with ISO 1133-1, have been demonstrated in an intercomparison of melt volume flow rate measurements on PET, PBT, PA6 and PA66 materials, along with a PP grade used as a control. For further information, see Reference [5].

Bibliography

- [1] ISO 307, *Plastics — Polyamides — Determination of viscosity number*
- [2] ISO 1628 (all parts), *Plastics — Determination of the viscosity of polymers in dilute solution using capillary viscometers*
- [3] ISO 7391-2, *Plastics — Polycarbonate (PC) moulding and extrusion materials — Part 2: Preparation of test specimens and determination of properties*
- [4] ISO 14910-2, *Plastics — Thermoplastic polyester/ester and polyether/ester elastomers for moulding and extrusion — Part 2: Preparation of test specimens and determination of properties*
- [5] RIDES, M., ALLEN, C., OMLoo, H., NAKAYAMA, K., CANCELLI, G. Interlaboratory comparison of melt flow rate testing of moisture sensitive plastics. *Polym. Test.* 2009, **28**, pp. 572-591

Bureau of Indian Standards

BIS is a statutory institution established under the *Bureau of Indian Standards Act, 1986* to promote harmonious development of the activities of standardization, marking and quality certification of goods and attending to connected matters in the country.

Copyright

BIS has the copyright of all its publications. No part of these publications may be reproduced in any form without the prior permission in writing of BIS. This does not preclude the free use, in course of implementing the standard, of necessary details, such as symbols and sizes, type or grade designations. Enquiries relating to copyright be addressed to the Director (Publications), BIS.

Review of Indian Standards

Amendments are issued to standards as the need arises on the basis of comments. Standards are also reviewed periodically; a standard along with amendments is reaffirmed when such review indicates that no changes are needed; if the review indicates that changes are needed, it is taken up for revision. Users of Indian Standards should ascertain that they are in possession of the latest amendments or edition by referring to the latest issue of 'BIS Catalogue' and 'Standards: Monthly Additions'.

This Indian Standard has been developed from Doc No.: PCD 27 (02486).

Amendments Issued Since Publication

Amendment No.	Date of Issue	Text Affected

BUREAU OF INDIAN STANDARDS

Headquarters:

Manak Bhavan, 9 Bahadur Shah Zafar Marg, New Delhi 110002

Telephones: 2323 0131, 2323 3375, 2323 9402

Website: www.bis.org.in

Regional Offices:

Telephones

Central	: Manak Bhavan, 9 Bahadur Shah Zafar Marg NEW DELHI 110002	{ 2323 7617 2323 3841
Eastern	: 1/14, C.I.T. Scheme VII M, V.I.P. Road, Kankurgachi KOLKATA 700054	{ 2337 8499, 2337 8561 2337 8626, 2337 9120
Northern	: SCO 335-336, Sector 34-A, CHANDIGARH 160022	{ 260 3843 260 9285
Southern	: C.I.T. Campus, IV Cross Road, CHENNAI 600113	{ 2254 1216, 2254 1442 2254 2519, 2254 2315
Western	: Manakalaya, E9 MIDC, Marol, Andheri (East) MUMBAI 400093	{ 2832 9295, 2832 7858 2832 7891, 2832 7892

Branches: AHMEDABAD. BANGALORE. BHOPAL. BHUBANESHWAR. COIMBATORE. DEHRADUN. FARIDABAD. GHAZIABAD. GUWAHATI. HYDERABAD. JAIPUR. KANPUR. KOCHI. LUCKNOW. NAGPUR. PARWANOO. PATNA. PUNE. RAJKOT. VISAKHAPATNAM.