

---

---

# भवनों को तोड़ना — सुरक्षा संहिता

( तीसरा पुनरीक्षण )

## Demolition of Buildings — Code of Safety

( Third Revision )

ICS 91.200

© BIS 2024



भारतीय मानक ब्यूरो  
BUREAU OF INDIAN STANDARDS  
मानक भवन, 9 बहादुर शाह ज़फर मार्ग, नई दिल्ली - 110002  
MANAK BHAVAN, 9 BAHADUR SHAH ZAFAR MARG  
NEW DELHI - 110002  
[www.bis.gov.in](http://www.bis.gov.in) [www.standardsbis.in](http://www.standardsbis.in)

## FOREWORD

This Indian Standard (Third Revision) was adopted by the Bureau of Indian Standards, after the draft finalized by the Safety in Construction Sectional Committee had been approved by the Civil Engineering Division Council.

Demolition of any structure is inherently more hazardous than the construction or erection of the same. From the point of view of safety, the conditions usually encountered while dismantling a structure, whatever its magnitude, do not lend themselves to the degree of control possible in construction operations, where more stable conditions are generally obtainable.

Generally, the time available and the equipment possible to obtain are the elements limiting the application of strict safety rules; but these should not, in any case, be allowed to endanger the safety of human life or limbs. Although, everyone in-charge of a demolition work is always desirous of preventing accidents, lack of readily available systematic procedures or rules, observance of which will ensure safety in demolition operation, has sometimes led to dangerous situations and actual accidents.

It is imperative, therefore, that adequate attention is given to the planning and the execution of demolition work, its various stages, so as to minimize the risk of accidents and injuries to the personnel engaged on demolition operations. Adoption of predetermined and well-planned safety measures for demolition work will not only prevent accidents but also will increase all-round efficiency.

It has therefore, become imperative that certain safety rules are laid down for the guidance of those who are engaged in demolition work, so that they may be meticulously followed.

This standard was first published in 1967 and subsequently revised in 1976 and 1991. The present revision has been taken up based on the experience gained with the use of this standard and the technological improvement in the country. This standard is expected to guide practitioners and stakeholders in safe demolition practices in the country. In this revision, the following major changes are incorporated:

- a) Modern demolition practices such as demolition through implosion, mechanical demolition, etc;
- b) An [Annex B](#) on list of demolition methodologies;
- c) An [Annex C](#) on general checklist; and
- d) An [Annex D](#) on safety signages.

In the formulation of this standard due weightage has been given to international coordination among the standards and practices prevailing in different countries in addition to relating it to the practices in the field in this country. This has been met by deriving assistance from the following publications:

- a) Demolition work code of practice, 2012, Australia;
- b) Occupational safety and health — demolition of buildings — code of practice Kenya Standard, DKS 2867 : 2018;
- c) Construction health and safety manual — Volume 1; published by Construction Industry Publication; and
- d) Safety and health in construction — International Labour Office Geneva.

The composition of the Committee responsible for the formulation of this standard is given in [Annex E](#).

This standard contributes to the United Nations Sustainable Development Goal 9: ‘Industry, innovation and infrastructure’, particularly its target to develop quality, reliable, sustainable and resilient infrastructure, and also promote inclusive and sustainable industrialization.

For the purpose of deciding whether a particular requirement of this standard is complied with the final value, observed or calculated, expressing the result of a test or analysis shall be rounded off in accordance with IS 2 : 2022 ‘Rules for rounding off numerical values (*second revision*)’. The number of significant places retained in the rounded off value should be the same as that of the specified value in this standard.

*Indian Standard***DEMOLITION OF BUILDINGS — CODE OF SAFETY***( Third Revision )***1 SCOPE**

**1.1** This standard lays down the requirements for safely carrying out the demolition/dismantling of all types of buildings, for example, residential building (load-bearing structure, multi-storeyed framed structures), public buildings and factories.

**1.2** The provision of this standard excludes demolition of special structures such as nuclear plants, dams, underwater installations, etc.

**1.3** This standard excludes the provisions under IS 13430 'Safety during additional construction and alteration to existing buildings — Code of practice'.

**2 REFERENCES**

The standards listed in [Annex A](#) contain provisions which, through reference in this text, constitute provisions of this standard. At the time of publication, the editions indicated were valid. All standards are subject to revision and parties to agreements based on this standard are encouraged to investigate the possibility of applying the most recent edition of these standards.

**3 TERMINOLOGY**

For the purpose of this standard, the following terms and their definitions shall apply.

**3.1 Canopy** — Canopy is a temporary structure erected on top of the covered walkway or underneath the structures that are being demolished including, but not limited to, balconies and cantilevered structures for the purpose of catching and retaining debris and to protect the public beneath such structures being demolished.

**3.2 Client/Occupant** — The responsible person in-charge of the project site (who might not be the owner) while the demolition activity is being carried out.

**3.3 Competent Person** — Person possessing sufficient qualifications knowledge, experience, and ability to perform the assigned task, with sufficient training and able to analyse the hazards involved in the work to be carried out, and manage them with appropriate control measures.

**3.4 Contractor** — A person or firm that undertakes a contract to provide machine, materials and manpower to perform a demolition activity.

**3.5 Demolition** — Any activity of dismantling, razing, destroying, or wrecking of any building or structure or any part thereof by manual method, mechanical method or any other suitable method.

**3.6 Exclusion Zone** — An exclusion zone is the designated area surrounding a demolition site that may be impacted by the demolition activities. This zone is typically off-limits to anyone when critical demolition tasks are being executed.

**3.7 Explosion** — The mechanical and thermal effect of the chemical reaction of an explosive during detonation or deflagration in confinement. High-rise structures may be brought down by implosion methods using specialized explosives.

**3.8 Manual Demolition** — Demolition of building carried out using hand-held pneumatic hammers, circulated diamond saws and any other suitable equipment.

**3.9 Owner** — Person or organization who has legal title for land or building and have the right to demolish or refurbish a building.

**3.10 Permit to Work** — The document specifying the conditions and procedures for safe execution of the work and allows the work to be carried out under controlled risk conditions.

**3.11 Waste** — Material that gets separated or broken as a result of the demolition process and must be removed for recycling or disposal.

**3.12 Workers** — Persons involved in demolition, collection of waste and other activities related to demolition operations.

**4 PLANNING**

**4.1** Before beginning the actual work of demolition,

a careful study shall be made of the structure which is to be pulled down and of all its surroundings.

**4.2** It shall be ensured that the demolition operations do not, at any stage, endanger the safety of the adjoining buildings or their occupants or passers-by. Moreover, the adverse effect of the demolishing work on the use of the adjacent buildings shall be kept to the minimum.

**4.3** During the demolition, no structure or part of the structure or any floor or temporary support or scaffold, side wall or any device for equipment shall be loaded in excess of the safe carrying capacity, in its then existing condition.

#### **4.4 Factors to be Considered Prior to Demolition**

When selecting a demolition method, the following factors shall be taken into consideration:

- a) The needs of the building owner, the client and the workmen.
- b) Identifying the hazardous materials that could be generated during or after demolition and preparing methods for their safe disposal.
- c) Information related to the structure, material used, electrical system, plumbing system, HVAC system, presence of hazardous chemicals if any, information on utilities, etc shall be collected.
- d) Health, safety, and environmental regulatory requirements.
- e) The type, age, condition, use and business activity (if appropriate) of the facility and local conditions and constraints (for example, access, existing services, party walls).
- f) Potential for disruption to business continuity, the community and nearby structures.
- g) Legislative requirements.
- h) Wherever possible, details of the previous use should be obtained to identify any possible contamination and hazards from chemicals, flammables, etc.
- j) All electric, gas, water drainage and communication service lines should be shut off and, as necessary, capped or otherwise controlled at or outside the construction site before work commences.
- k) Tanks, pressure vessels and similar

structures located within the demolition zone shall be identified and shall be evacuated through depletion, transfer to other storage, or venting or as per applicable good practice. With the exception of those designated for continued use that may be damaged by atmospheric exposure, tanks and vessels will be left open to the atmosphere once the contents have been evacuated.

- m) Piping, tubing, compressors, pumps, hoists, and other equipment with refrigerants, oil or hydraulic fluid shall be identified and shall be drained completely by a licensed contractor. The contents will be captured, characterized, and transported as appropriate to a disposal or recycling facility.
- n) Insurance and other incidental costs, and income from disposed materials, if any.

#### **4.5 Site Survey**

The contractor or other appointed party tasked with the demolition shall have a thorough knowledge of the site and shall be competent to assess and survey the site to check, manage and implement the following:

- a) Extent of demolition;
- b) Details of the isolation or removal of services and details of temporary utilities;
- c) Knowledge and history of the structure, including configuration, materials of construction, structural interactions and location;
- d) Isolation and protection measures for adjacent structures;
- e) Presence of hazardous materials;
- f) Previous uses of the site;
- g) Possible presence of any overhead and underground services (example presence of tanks, pressure vessels, piping, tubing and other sensitive utilities) in and around the site that may be affected during demolition, with assistance sought from relevant authority as necessary;
- h) To manage, contain and safely dispose of the contaminated water, if any, generated during the demolition process; and
- j) Survey to identify the presence of piping, tubing, compressors, pumps, hoists, and other equipment with refrigerants, oil or hydraulic fluid shall be carried out.

#### 4.6 Engineering Survey Report

An engineering survey report shall include the following:

- a) Building characteristics (that is, construction type and structure size, height, structural hazards, enclosed/confined spaces, wall ties, shoring types and locations);
- b) Modelling for collapse analysis, if required;
- c) Protection for adjacent structures;
- d) Methods for demolition;
- e) Methods to protect the public;
- f) Protection of utilities (overhead and underground);
- g) Protection of above and below ground tanks;
- h) Identifying hazardous material and methods for their safe disposal;
- j) Blasting requirements; and
- k) Training requirements.

#### 4.7 Permissions, Consents and Licenses

Early consideration shall be given to ascertain whether any permissions, consents or permits/licenses are required for the demolition works and whether any special measures need to be put in place, particularly for works on dangerous structures or special sites (for example, nuclear, petrochemical or other hazardous industry sites or buildings) and for works which could:

- a) Affect a public or private road, highway, rail line, waterway for example, works which necessitate:
  - 1) The partial or total closure of the road, highway, rail line or waterway;
  - 2) The erection of temporary structures (example, scaffolds, canopy, screens, hoardings and supports) on or over the road or highway;
  - 3) The use of plant or equipment on or over the road or highway; and
  - 4) The storage of site vehicles on the road or highway.
- b) Affect features outside the legal limits of the site (example, footway lights, vaults and other voids under a highway);
- c) Affect access routes, for example, to an adjoining property or utilities;

- d) Involve scaffolding or a crane jib passing over an adjoining property;
- e) Involve the burning of waste on site;
- f) Involve using explosives in demolition, for which local permissions from competent authorities shall be obtained; and
- g) Affect utilities like power lines, gas, water supply etc, NOC shall be obtained from competent authority prior to demolition.

#### 4.8 Health and Safety Plan

The contractor or other entity assigned the demolition shall follow IS 15883 (Part 5) and prepare a health and safety plan, which shall include the following:

- a) The sequence and method of demolition with details on means of access, working platform and plant and equipment requirements;
- b) Specific details of and pre-weakening of structure or use of explosive;
- c) Arrangements for the protection of persons employed on site and members of public;
- d) Details of removal or making safe of electric, gas or other service;
- e) Details on temporary service which are available or will be required;
- f) Methods for dealing with flammable materials and gases which may remain from previous processes or storage, or may arise during the demolition;
- g) Methods of determining the presence of hazardous substances, the means of disposal of such substance and the requirements for any protective equipment;
- h) Arrangements for controlling transport used for the removal of waste;
- j) Arrangements for controlling noise, dust and vibration generated prior, during and after demolition; and
- k) Identifying persons with specific responsibilities for the control and co-ordination of safety arrangements.

### 5 PRECAUTIONS BEFORE STARTING DEMOLITION WORK

**5.1** On every demolition job, safety signages shall be conspicuously posted all around the site demolition area. Structure, all doors and openings giving access to the structure shall be kept barricaded or manned

except during the actual passage of workmen or equipment. Provision shall be made for at least two independent exits for escape of workmen during emergency.

**5.2** During nights, solar blinkers (at least 125 V; 55 W), LED rope light (at least 230 V; 36 W) or any other suitable means of red colour emitting lights shall be placed on all the barricades provided around the demolition sites. No demolition activity is permitted during night.

**5.3** Where in any work of demolition it is imperative, because of inherent danger, to ensure that no unauthorized person shall enter the site of demolition outside working hours; a security person/unit shall be employed. In addition to watching the site, the person/unit shall also be responsible for maintaining all notices, lights and barricades.

**5.4** All the necessary safety appliances shall be issued to the workers and their use explained. It shall be ensured that the workers use correctly all the safety appliances required for the work.

**5.5** The removal of say, a structural member may weaken the side wall of an adjoining structure and to prevent possible damage, these walls shall be supported until such time as permanent protection is provided. In case any danger is anticipated to the adjoining structure, the same shall be got vacated to avoid any danger to human life.

**5.6** The power on all electrical service lines shall be shut off and all such lines cut or disconnected at or outside the property line, before the demolition work is started. Prior to cutting of such lines, the necessary approval shall be obtained from the electrical authorities concerned. The only exception will be any power lines required for demolition work itself. Alternatively, the implicated service lines may be moved away to sufficient distance until the task is completed. If both above options are not feasible, adequate protection against accidental contact such as rubber shielding shall be provided.

**5.7** All gas, water steam, sewage and other service lines shall be shut off and capped or otherwise controlled at or outside the building line, before demolition work is started.

**5.8** All the mains and meters of the building shall be removed or protected from damage.

**5.9** If a structure to be demolished has been partially wrecked by fire, explosion or other catastrophe, the walls and damaged roofs shall be shored or braced suitably.

**5.10** Protected walkways and passageways shall be provided for the use of the workmen who shall be instructed to use them and all such walkways and passageways shall be kept adequately lighted, free from debris and other materials.

**5.11** All nails in any kind of lumber shall be removed, hammered or bent over as soon as such lumber is removed, from the structure being demolished, and placed in piles for future cleaning or burning.

**5.12** Assistance shall be sought from relevant authority to deal with overhead and underground services in and around the demolition site.

**5.13** Reduced voltage with a centre point earth connection, should be used where possible.

**5.14** Temporary electrical supplies/service should be installed to the same standard as for other construction activities.

**5.15** Where a supply is to be derived from street lighting systems, the permission of the appropriate supplier must be obtained and adequate precautions should be taken to avoid danger to the public at the main connections.

**5.16** Where existing plant has contained flammable materials and gases, special precautions must be observed to avoid fire or explosion. The assistance of a competent analyst may be required to identify residues, carry out air monitoring and assess whether pockets of contamination remain. Any residual flammable materials and gases must be rendered safe by for example, cleaning, purging or the application of an inert gas.

**5.17** Exclusion zone shall be demarcated and completely clear of any public access, allowing only authorized personnel to be present within. The size and boundary of the exclusion zone shall be determined on a case-by-case basis following a thorough risk assessment.

## **6 PROTECTION TO THE PUBLIC**

**6.1** Before any demolition work is started, every footpath or road adjacent to the work likely to be affected shall be closed or protected, and alternatives provided for the diverted traffic.

**6.2** Children and members of the public shall be kept out of the building and the adjoining yard.

**6.3** If the structure to be demolished is more than two storeyed or 7.5 m high, measured from the

footpath or street which cannot be closed or safely diverted, and the horizontal distance from the inside of the footpath to the structure is 4.5 m or with less a substantial footpath canopy (see Fig. 1) shall be constructed over the entire length of the footpath adjacent to the structure of sufficient width to protect pedestrian traffic on the footpath from falling debris or other materials. The footpath canopy

shall be lighted sufficiently to ensure at all times.

6.4 A toe board of at least 1 m high above the roof of the canopy shall be there, provided on the outside edge and ends of the footpath canopy. Such boards may be vertical or inclined outward at not more than 45°.

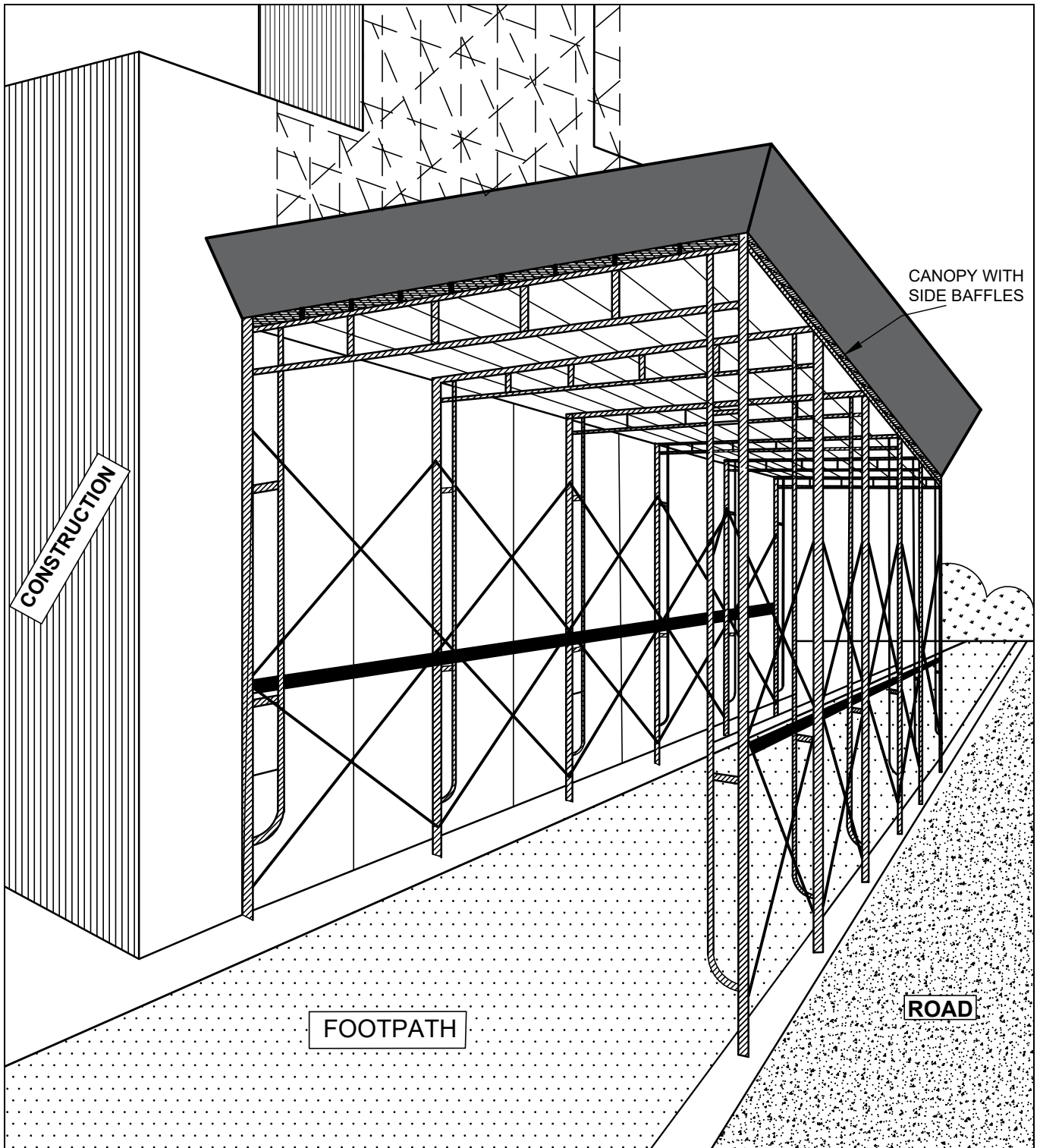

FIG. 1 TYPICAL SKETCH OF A SIDE CANOPY

**6.5** Except where the roof of a footpath canopy solidly abuts the structure, the face of the footpath canopy towards the building shall be completely closed by providing sheeting planking to prevent falling material from penetrating into the canopy.

**6.6** The roof of footpath canopy shall be capable of sustaining a load of 0.75 kN/m<sup>2</sup>. Only in exceptional cases, say due to lack of other space, the storing of material on a footpath canopy may be permitted in which case the canopy shall be designed for a load of 1.50 kN/m<sup>2</sup>. Roof of footpath canopy shall be designed considering the impact of the falling debris. By frequent removal of loads it shall be ensured that the maximum load, at any time, on the roof of work canopy is not more than 6 kN/m<sup>2</sup>. The height of footpath canopy shall be such as to give a minimum clearance of 2.5 m.

**6.7** Any opening in the canopy for personnel or deliveries access shall be kept closed at all time except during actual loading operations.

**6.8** The deck flooring of the footpath canopy shall consist of plank of not less than 20 mm in thickness closely laid and deck made watertight. All members of the canopy shall be adequately braced and connected to resist displacement of members or distortion of framework.

**6.9** When the horizontal distance from the inside of the footpath to the structure is more than 4.5 m and less than 7.5 m, a footpath canopy or fence may be built or in place of such a canopy or fence a substantial railing shall be constructed on the inside of the footpath or roadway along the entire length of the demolition side of the property with access gates as may be necessary for the proper execution of the work.

**6.10** Where worker's entrances to the building being demolished are not completely protected by footpath canopies, all such entrances shall be protected by canopies extending from the face of the building to a point not less than 2.5 m from it. Such overhead protection shall be at least 0.6 m wider than the building entrance or opening and every canopy shall be as strong as the footpath canopy, specified in [6.6](#).

## **7 SEQUENCE OF DEMOLITION OPERATIONS**

**7.1** The demolition work shall proceed with, in such a way that:

- a) it causes the least damage and adverse effect on adjoining buildings and the members of the public; and
- b) it satisfies all safety requirements enumerated in this standard.

**7.2** All existing fixtures required during demolition operations shall be well protected with substantial covering to the entire satisfaction of the rules and regulations of the undertakings or they shall be temporarily relocated.

**7.3** Before demolition work is started, glazed sash, glazed doors and windows, etc shall be removed. All fragile and loose fixtures shall be removed. The lath and all loose plaster shall be stripped off throughout the entire building. This is advantageous because it reduces glass breakage and eliminates a large amount of dust producing material before more substantial parts of the buildings are removed.

**7.4** All wall openings which extend down to floor level shall be barricaded to a height of not less than one metre above the floor level. This provision shall not apply to the ground level floor.

**7.5** All floor openings and shafts not used for material chutes shall be floored over and be enclosed with guard rails and toe boards.

**7.6** The demolition shall always proceed systematically storey by storey in descending order and the work on the upper floors shall be completely over before any of the supporting members or other important portion on the lower floor is disturbed. These requirements shall not prohibit the demolition of structure in sections, if means are taken to prevent injuries, to persons or damage to property.

## **8 REMOVAL OF MATERIALS**

### **8.1 General**

Dismantled materials may be thrown to the ground only after taking adequate precautions and IS 13416 (Part 3) shall be followed. The material shall preferably be dumped inside the building. Normally such materials shall be lowered to the ground or to the top of the footpath canopy where provided by means of ropes or suitable tackles (*see also* [6.6](#)).

### **8.2 Through Chutes**

**8.2.1** Wooden, metal or plastic chutes may be provided for disposal of materials. The chutes shall preferably be provided at the centre of the building, or, if more than one, appropriately distributed along its width for efficient disposal of debris.

**8.2.2** Chutes, if provided at an angle of more than 45° from the horizontal, shall be entirely enclosed on all the four sides, except for opening at or about the floor level for receiving the materials.

**8.2.3** Opening for the chutes (*see* [8.3](#)) shall not exceed 1.20 m in height measured along the wall of



the chute and in all storeys below the top floor such opening shall be kept closed when not in use.

**8.2.4** To prevent the descending material attaining a dangerous speed, chute shall not extend in an unbroken line for more than two storeys. A gate or stop shall be provided with suitable means for closing at the bottom of each chute to stop the flow of materials.

**8.2.5** Chute at an angle of less than 45° to the horizontal may be left open on the upper side provided that at the point where such a chute discharges into a chute steeper than 45° to the horizontal, the top of the steeper chute shall be boarded over to prevent the escape of materials.

**8.2.6** The chutes shall end into a metal bin for easy disposal and less dust.

**8.2.7** Any opening into which workmen dump debris at the top of chute shall be guarded by a substantial guard rail extending at least one metre above the level of the floor or other surface on which men stand to dump the materials into the chute.

**8.2.8** A toe board or bumper, not less than 50 mm thick and 150 mm high shall be provided at each chute opening, if the material is dumped from the wheelbarrows. Any space between the chute and the edge of the opening in the floor through which it passes shall be solidly planked over.

### **8.3 Through Holes in the Floor**

**8.3.1** Debris may also be dropped through holes in the floor without the use of chutes. In such a case the total area of the hole cut in any intermediate floor, one which lies between floor that is being demolished and the storage floor shall not exceed 25 percent of such floor area unless the lateral supports of the removed flooring remain in place. It shall be ensured that the storage floor is of adequate strength to withstand the impact of the falling material.

**8.3.2** Openings in all the floors below the floor from which materials are being removed, shall be protected by standard railings and toe boards or preferably planked over when the holes are not being used for dumping materials.

**8.3.3** All intermediate floor openings for passage of materials shall be completely enclosed with barricades or guard rails not less than one metre high and at a distance of not less than one metre from the edge of general opening. No barricades or guard rails shall be removed until the intermediate floor in question is itself ready for demolition and all debris cleared from the floor.

**8.3.4** When the cutting of a hole in an intermediate floor between the storage floor and the floor which is being demolished makes the intermediate floor or any portion of it unsafe, then such intermediate floor shall be properly shored. It shall also be ensured that the supporting walls are not kept without adequate lateral restraints.

**8.3.5** Opening at grade level shall be kept to the minimum size in order not to weaken the structure. Professional engineer maybe consulted if a larger opening is required.

### **8.4 Removal of Debris**

**8.4.1** As demolition work proceeds, the released serviceable materials of different types shall be separated from the unserviceable lot at suitable time intervals and properly stocked clear of the spots where demolition work is being done.

**8.4.2** The Debris obtained during demolition shall be collected in well-formed heaps at properly selected places, keeping in view safe conditions for workmen in the area. The height of each debris heap shall be limited to ensure its not toppling over or otherwise endangering the safety of workmen or passers-by.

**8.4.3** The Debris shall be removed from the demolition site to a final disposal or recycling location as required by the local bodies or civil authorities. Depending on the space available at the demolition site, this operation of conveying debris to its final disposal location or recycling location may have to be carried out a number of times during the demolition work. In any case, the demolition work shall not be considered as completed and the area declared fit for further occupation till all the debris has been carried to its final disposal location or recycling location and the demolition area cleaned up.

**8.4.4** Materials which are likely to cause dust nuisance or undue environmental pollution in any other way, shall be removed from the site at the earliest and till then they shall be suitably covered. Such materials shall be covered during transportation also.

**8.4.5** Materials from demolition which are likely to include asbestos, lead or other hazardous materials shall be collected with workers wearing appropriate PPE, bagged separately and disposed of safely complying with local regulation.

**8.4.6** Unauthorized use of the debris from any work shall not be permitted. The released materials classed as 'serviceable' shall be inspected by a competent person before being used.

**8.4.7** The foreman should determine when debris is to be removed, halt all demolition during debris removal, and make sure the area is clear of clean-up workers before continuing demolition.

**8.4.8** If debris is dropped inside the shaft, it can be removed through an opening in the structure at grade level.

**8.4.9** When the debris is removed at the bottom of the shaft, the personnel involved, whether manually or by machine, shall be suitably protected from falling debris and other incidental physical and chemical hazards.

**8.4.10** Do not allow excessive debris to accumulate inside or outside the shaft of the chute as the excess weight of the debris can impose pressure on the wall of the structure and might cause the shaft to collapse.

## **9 STAIRS, PASSAGEWAYS AND LADDERS**

**9.1** Stairs and stair railings, passageways and ladders shall be left in place as long as possible.

**9.2** For the use of ladders, provisions laid down in IS 3696 (Part 2) shall be followed.

**9.3** All stairs, passageways and ladders to be used by workmen during the process of demolition shall be maintained in a safe condition.

**9.4** Ladders or their side rail extend not less than 1.0 m above the floor or platform to which such ladder gives access.

**9.5** All ladders shall be secured against, slipping out at the bottom and against movement in any direction at the top.

## **10 DEMOLITION OF WALLS**

**10.1** Top-down methodology shall be adopted, that is; demolishing from the top floor level progressively floor by floor, down to ground, with an exception wherever demolition methodology is engineered and designed otherwise.

**10.2** While walls or sections of masonry are being demolished, it shall be ensured that they are not allowed to fall as single mass upon the floors of the building that are being demolished to exceed the safe carrying capacity of the floors. Overloading of floors shall be prevented by removing the accumulating debris through chutes or by other means immediately. The floor shall be inspected by the engineer in-charge before undertaking demolition work and if the same is found to be incapable to carry the load of the debris, necessary

additional precautions shall be taken to prevent any possible unexpected collapse of the floor.

**10.3** Walls shall be removed part by part. Stages shall be provided for the men to work on, if the walls are very thin and dangerous to work by standing over them.

**10.4** No section of wall whose height is more than 15 times of thickness, shall be permitted to stand without lateral bracing unless such wall is in good condition and was originally designed to stand without such lateral bracing or support.

**10.5** Structural or load supporting members on any floor shall not be cut or removed until all the storeys above that floor have been demolished and removed.

**10.6** Before demolishing any interior or exterior wall within 3 m of the opening in the floor immediately below, such opening shall be substantially planked over, unless access is denied to workmen to that portion of the area of the floor immediately below the opening, in the floor of the storey being demolished, where any debris pieces passing through this opening may fall.

**10.7** In framed structures, the steel frame may be left in place during demolition of masonry work. Where this is done, all steel beams, girders, etc, shall be cleared of all loose materials as the demolition of masonry work progress downward provided it is still strong enough to stand as an independent structure.

**10.8** Walkways shall be provided to enable workmen to reach or leave their work on any scaffold or wall. Such walkways shall be not less than 3 planks, nor less than 0.8 m in width.

**10.9** At the completion of each day's work, all walls shall be left stable to avoid any danger of getting overturned.

**10.10** Foundation walls which serve as retaining walls to support earth or adjoining structure, shall not be demolished until such an adjoining structure has been underpinned or braced and the earth removed by sheet piling or sheathing.

**10.11** Demolition work shall be suspended in case of adverse weather condition.

**10.12** Do not use walls which serve as retaining walls against which debris will be piled unless they can support the imposed load.

**10.13** Dismantle steel construction, column length by column length, and tier by tier.

## 11 MANUAL DEMOLITION OF ROOFS

During the manual demolition of the roofs following shall be considered:

- a) Fall hazards;
- b) Structural stability;
- c) Condition and strength of the roofing material and the identification of fragile roofing;
- d) Identification of fragile panels or skylights in solid roofs;
- e) Crane access;
- f) Safe worker access and egress;
- g) Fall protection requirements including issues such as perimeter protection, the availability and strength of anchor points for static lines, inertia reels and lanyards and the suitability of roof structure for the use of safety nets;
- h) Means of rescuing persons from safety nets or safety harness;
- j) The condition of any roof mesh or safety mesh;
- k) Methods of raising and lowering equipment and materials;
- m) Assessment of manual handling problems;
- n) Electrical safety including the location of nearby power line; and
- p) Worker competency and training needs.

## 12 DEMOLITION OF FLOORS

**12.1** In cutting holes in a floor which spans in one direction, a slit of width not exceeding 300 mm shall be cut at the first stage for the entire length of the slab along which it spans (see Fig. 2). The opening shall thereafter be increased.

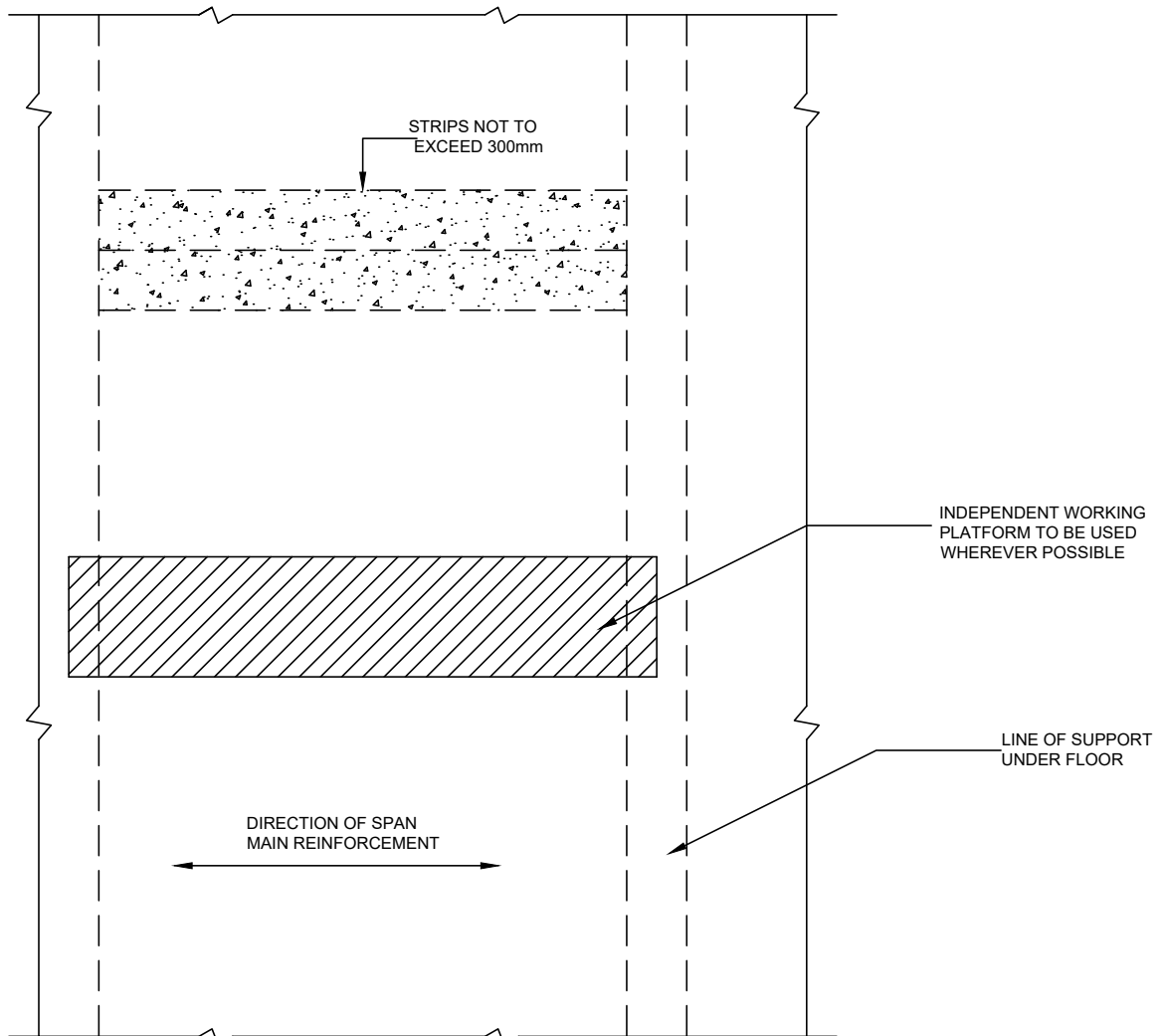

FIG. 2 PLAN VIEW OF DEMOLITION OF REINFORCED CONCRETE FLOORS

**12.2** Planks of sufficient strength of thickness not less than 50 mm and 250 mm width shall be provided at spacing not greater than 400 mm for the workmen to work. The length of planks shall not be less than 2 000 mm. These planks shall be so placed as to give workmen trim support to guard against any unexpected floor collapse.

**12.3** Stringers of ample strength shall be installed to support the planks where necessary and the ends of such stringer shall be supported by floor beams, girders and not by floor slab alone.

**12.4** When floors are being removed, no workmen shall be allowed to work in the area, directly underneath and such area shall be barricaded to prevent access to it.

**12.5** The demolition of floor shall be started only after the floor in question and the surrounding floor area for a distance of 6.0 m have been entirely cleared of persons, and the debris and other unnecessary material removed.

**12.6** Planks used for temporary protection shall be sound and at least 50 mm thick. They shall be laid close together with the ends having at least 100 mm bearing over solid support to prevent tipping under load. If corrugated GI sheets are used for temporary protection, it shall be secured to the solid support with suitable framework.

### **13 DEMOLITION OF STEEL STRUCTURES**

**13.1** When a derrick is used, care shall be taken to see that the floor on which it is supported is amply strong for the loading so imposed. If necessary heavy planking shall be used to distribute the load to floor beam and girders.

**13.2** Overloading of equipment shall not be allowed.

**13.3** Tag lines shall be used on all materials being lowered or hoisted up and a standard signal system shall be used and the workmen instructed on the signals.

**13.4** No person shall be permitted to ride the load line.

**13.5** No beams shall be cut until precautions have been taken to prevent it from swinging freely and possibly striking any worker or equipment to any part of the structure being demolished.

**13.6** All structural steel members shall be lowered from the building and shall not be allowed to drop.

**13.7** Steel construction should be demolished tier by tier.

### **14 CATCH PLATFORMS**

**14.1** In demolition of exterior wall of multi-storeyed structure, it is advisable to provide catch platform of heavy planking to prevent injuries to the worker working below and to the public, when the external walls are more than 20 m in height.

**14.2** Such catch platform shall be constructed and maintained not more than 3 storeys below the storey from which exterior wall is being demolished. When demolition has progressed to within 3 storeys of ground level, catch platform will not be considered necessary.

**14.3** Catch platforms shall not be less than 1.5 m in width, measured in a horizontal direction from the face of the structure and shall consist of outriggers and planks. Planks shall be laid tight together, without openings between them and the walls. Catch platform shall be provided with a continuous solid parapet along its outer edge of at least 1 m height. The parapet shall be constructed of the same specification as the platform.

**14.4** Catch platform can be constructed of material other than wood also, provided such material is of equal or greater strength.

**14.5** Catch platform shall be capable of sustaining a live load of not less than 6.1 kN/m<sup>2</sup>.

**14.6** The outriggers shall be of ample strength and shall not be spaced more than 3 m apart.

**14.7** Materials shall not be dumped on catch platform nor shall such catch platform be used for the storage of materials.

### **15 MECHANICAL DEMOLITION**

**15.1** When demolition is to be performed by mechanical devices, such as weight ball and power shovels, the following additional precautions shall be observed other than the individual procedures mentioned in different clauses and the procedures mentioned in IS 7293:

- a) The area shall be barricaded for a minimum distance of 1.5 times the height of the wall;
- b) While the mechanical device is in operation, no workmen shall be allowed to enter the building being demolished;
- c) The device shall be located so as to avoid contact with power line, falling debris, etc that may damage the device; and
- d) The mechanical device when being used shall not cause any damage to adjacent structure, adjacent utilities, power line, etc.

### 15.2 Mechanical Demolition of RCC Structure/Steel Structure/Brickwork

- a) Excavator mounted hydraulic concrete crusher may be used for demolishing RCC or brick structures, this is classified as 'silent demolition' as it generates no vibration and with very low noise while the demolition is carried out;
- b) For demolition of steel structures special steel shears may be used;
- c) For crushing concrete or cutting structural steel or crushing brick masonry hydraulic powerful attachments shall be used;
- d) Demolition shall be started from topmost slabs of the RCC structure and proceed inwards into the building;
- e) If a swinging weight is used for demolition, a safety zone having a width of at 1.5 times the height of the building or structure shall be maintained as exclusion zone;
- f) Swinging weights should be so controlled such that they cannot swing against any structure other than the one being demolished;
- g) Only mechanical lattice boom crane shall be used for demolition using swinging weight; and
- h) If a clamshell bucket is used for demolition handling, a safety zone extending 8 m from the line of travel of the bucket should be maintained.

15.3 Few of the machinery that are used in demolition work are mentioned as follow:

- a) Jack hammer machine;
- b) Diamond cutters;
- c) Static hydraulic splitter;
- d) Magnetic induction heating breaker;
- e) Hydraulic crusher;
- f) Hydraulic breaker;

- g) Steel shear;
- h) Demolition ball machine;
- j) Hydraulic pusher arm; and
- k) Robotic machines.

## 16 RECOMMENDATIONS FOR DEMOLITION OF CERTAIN SPECIAL TYPES AND ELEMENTS OF STRUCTURES

### 16.1 Roof Trusses

**16.1.1** If a building has a pitched roof, the roof structure should be removed to wall plate level by hand methods. Sufficient purlins and bracing should be retained to ensure stability of the remaining roof trusses while each individual truss is removed progressively.

**16.1.2** Temporary bracing should be added, where necessary, to maintain stability. The end frame opposite to the end where dismantling is commenced, or a convenient intermediate frame should be independently and securely guyed in both directions before work starts.

**16.1.3** On no account should the bottom tie of roof trusses be cut until the principal rafters are prevented from making outward movement.

### 16.2 Heavy Floor Beams

Heavy baulks of timber and steel beams should be supported before cutting at the extremities and should then be lowered to a safe working place.

### 16.3 Jack Arches

Where tie rods are present between main supporting beams, these should not be cut until after the arch or series of arches in the floor have been removed. Particular care should be exercised and full examination of this type of structure undertaken before demolition is commenced (see Fig. 3). The floor should be demolished in strips parallel to the span of the arch rings at right angles to the main floor beams.

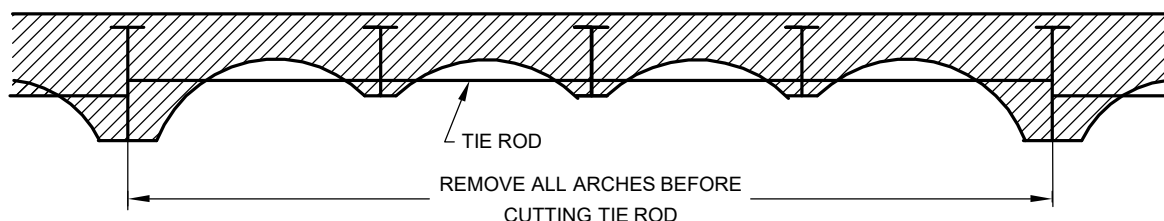

FIG. 3 DEMOLITION OF JACK ARCHES

## 16.4 Brick Arches

**16.4.1** Expert advice should be obtained and, at all stages of the demolition, the closest supervision should be given by persons fully experienced and conversant in the type of work to ensure that the structure is stable at all times.

**16.4.2** As much dead load as possible may be removed provided it does not interfere with the stability of the main arch rings but it should be noted that the load-carrying capacity, of many old arches rely on the filling between the spandrels. On no account should the restraining influence of the abutments be removed before the dead load of the spandrel fill and the arch rings are removed.

**16.4.2.1** The normal sequence of demolition is as shown in [Fig. 4A](#), namely:

- a) Remove spandrel after filling down it to the springing line;
- b) Remove the arch rings; and
- c) Remove the abutment.

**16.4.2.2** Special temporary support shall be provided in the case of skew bridges.

**16.4.3** A single span arch can be demolished by hand by cutting narrow segments progressively from each

springing parallel to the span of the arch, until the width of the arch has been reduced to a minimum which can then be collapsed (*see* [Fig. 4B](#)).

Where it is impossible to allow debris to fall to the ground below, centring designed to carry the load should be erected and the arch demolished progressively. The design of the centring should make appropriate allowance for impact.

**16.4.4** Where deliberate collapse is feasible the crown may be broken by the demolition ball and working progressively from edges to the centre (*see* [Fig. 4C](#)).

**16.4.5** Collapse of the structure can be affected in one action by the use of explosives. Charges should be inserted into boreholes drilled in both arch and abutments. This method is the most effective for demolition of tall viaducts.

**16.4.6** In multi-span arches before individual spans are removed, lateral restraint should be provided at the springing level. Demolition may then proceed as for a single span, care being taken to demolish the spandrels down to the springing line as the work proceeds (*see* [Fig. 4D](#)). Where explosives are used it is preferable to ensure the collapse of the whole structure in one operation to obviate the chance of leaving unstable portions standing.

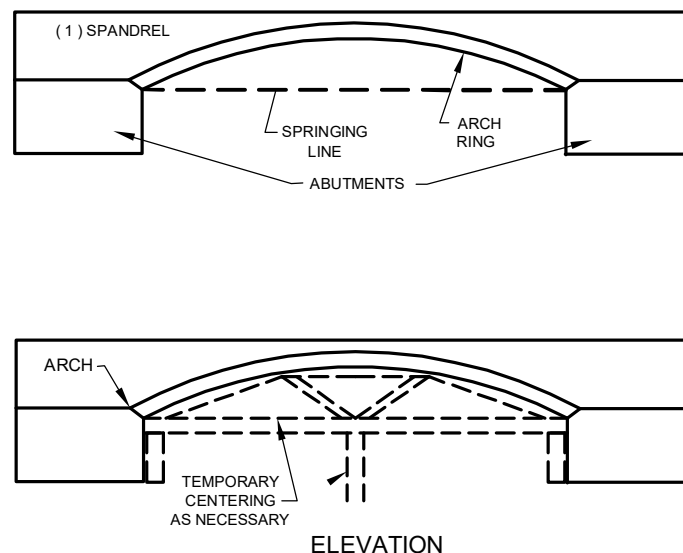
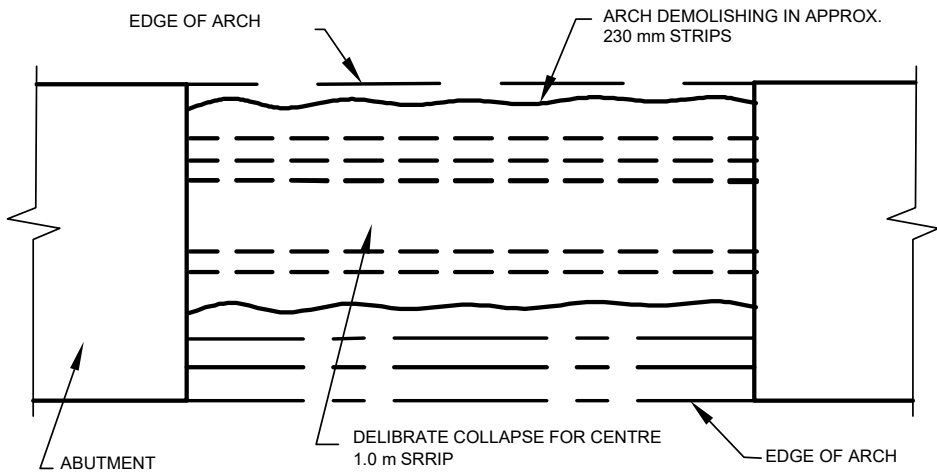

FIG. 4A



PLAN  
FIG. 4 B

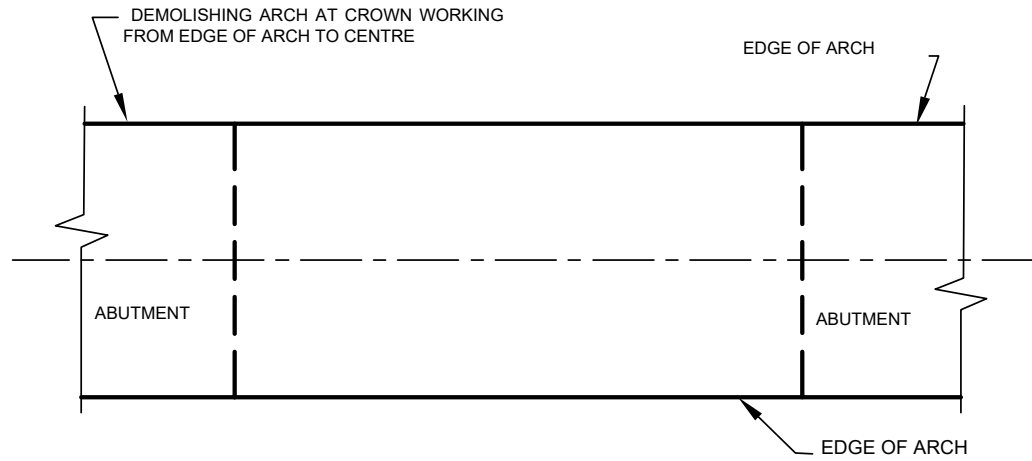

FIG. 4 C

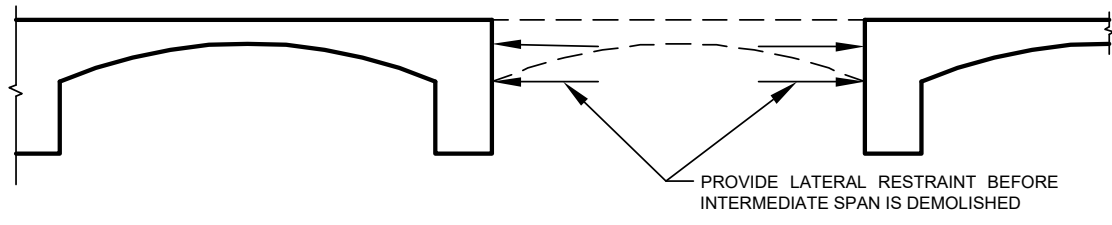

FIG. 4 D

NOTE — Order of Demolition

FIG. 4 DEMOLITION OF MASONRY AND BRICKWORK ARCHES

### 16.5 Cantilevers (Not Part of a Framed Structure)

A cantilever type of construction depends for its stability on the superimposed structure. Canopies, cornices, staircases and balconies should be demolished or supported before the tailing down, load is removed.

### 16.6 In-situ Reinforced Concrete

**16.6.1** Before commencing demolition, the nature and condition of the concrete, the condition and position of reinforcement, and the possibility of lack of continuity of reinforcement should be ascertained.

**16.6.1.1** Attention should be paid to the principles of the structural design to determine which parts of the structure depend on each other to maintain overall stability.

**16.6.2** Demolition should be commenced by removing partitions and external non-load bearing cladding. It should be noted that in some buildings the frame may rely on the panel walls for stability.

**16.6.2.1** Where manual demolition methods are to be used, the following procedures should be used:

- a) *Reinforced Concrete Beams* — For beams, a supporting rope should be attached to the beam. Then the concrete should be removed from both ends by pneumatic drill and the reinforcement exposed. The reinforcement should then be cut in such a way as to allow the beam to be lowered under control to the floor (see [Fig. 5A](#)).
- b) *Reinforced Concrete Columns* — For columns, the reinforcement should be exposed at the base after restraining wire guy ropes have been placed round the member at the top. The reinforcement should then be cut in such a way as to allow the column to be pulled down to the floor under control (see [Fig. 5B](#) for sequence of operations).
- c) *Reinforced Concrete Walls* — Reinforced concrete walls should be cut into strips and demolished as for columns (see [Fig. 5C](#)).
- d) *Suspended Floors and Roofs* — Before demolishing suspended floors and roofs, the type of construction should be ascertained. In solid slabs, the direction of the main reinforcement should be determined; the slab should then be cut into strips parallel to the main reinforcement and demolished strip by strip (see [12](#) and [Fig. 2](#)). Where ribbed construction has

been used, the principle of design and method of construction should be determined before demolition is commenced. Care should be taken not to cut the ribs inadvertently.

### 16.7 Precast Reinforced Concrete

**16.7.1** Precast reinforced concrete units used in a structure are normally held in position by the strength of the joints made in-situ or on supporting walls, etc. As such, before starting on demolition, the joint structures and/or the supporting mechanisms shall be studied and understood.

**16.7.2** In devising and following the demolition sequences due precaution shall be taken to avoid toppling over of prefabricated units or any other part of the structure and wherever necessary temporary supports shall be provided.

### 16.8 Prestressed Reinforced Concrete

**16.8.1** Prestressed concrete structures will have very high internal stresses locked into them by the high tension in the steel tendons or bars inside. Sudden release of the tension due to demolition may lead to catastrophic consequences, and hence expert attention will be needed.

#### 16.8.2 Pre-stressed Concrete Structures

The most important aspect of demolishing a pre-stressed concrete structure takes place during the engineering survey. During the survey, a qualified person shall determine if the structure to be demolished contains any pre-stressed members.

It is the responsibility of the demolition contractor to inform all workers on the demolition job site of the presence of pre-stressed concrete members within the structure. They should also instruct them in the safe work practice which must be followed to perform the demolition safely. Workers should be informed of the hazards of deviating from the prescribed procedures and the importance of following their supervisor's instruction.

#### 16.8.3 Pre-tensioned Members

Pre-tensioned members usually do not have any end anchors, the wires being embedded or bonded within the length of the member. The following shall be noted before demolition of pre-tensioned members:

- a) Before demolition of prestressed or post-tensioned member the internal locked in stresses should be neutralised;
- b) Advice of a structural expert should be taken;



- c) Demolish simple pre-tensioned beams and slabs of spans up to about 7 m in a manner similar to ordinary reinforced concrete;
- d) Lift and lower pre-tensioned beams and slabs to the ground as complete units after the removing composite concrete covering to tops and ends of the units;
- e) Turn the members on their sides to facilitate breaking up;
- f) Lift the structure from points near the ends of the units or from lifting point positions A (see Fig. 5);
- g) Whenever possible, reuse lifting eyes if they are in good condition; and
- h) When units are too large to be removed, consider temporary supporting arrangements.

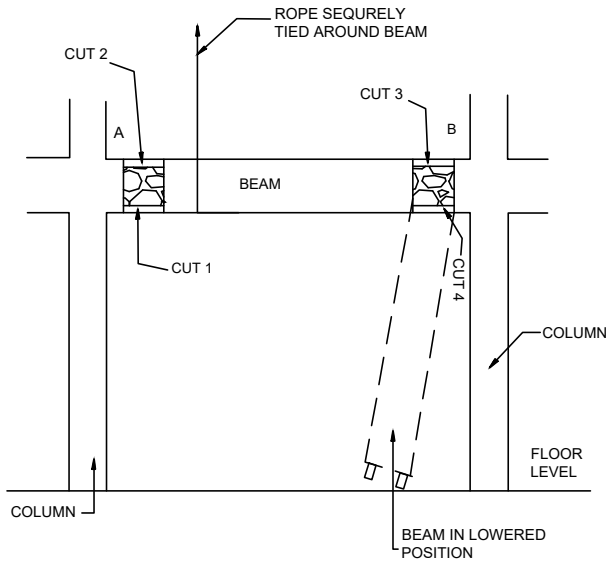

FIG. 5A BEAMS

RESTRAINING ROPE "Y"  
(IN OPPOSITE DIRECTION  
TO PULLING ROPE)

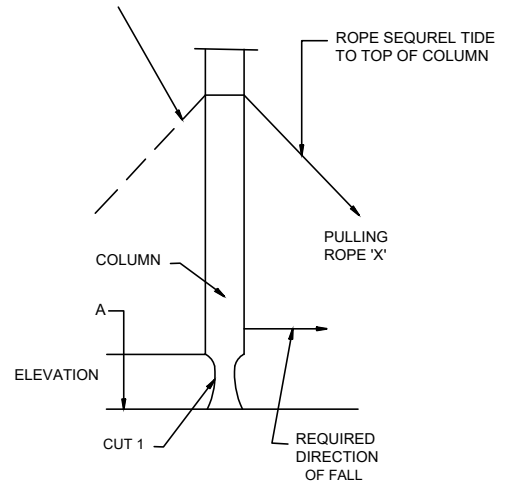

FIG. 5B COLUMNS

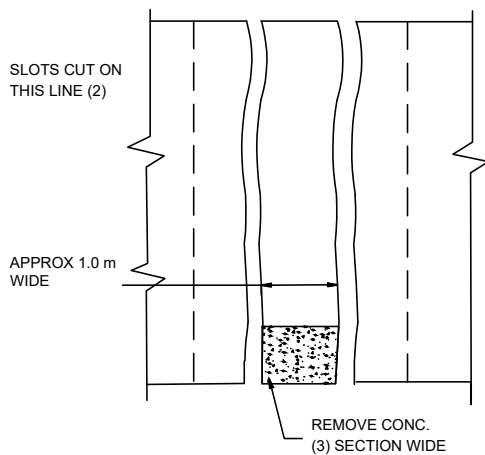

FIG. 5C WALLS

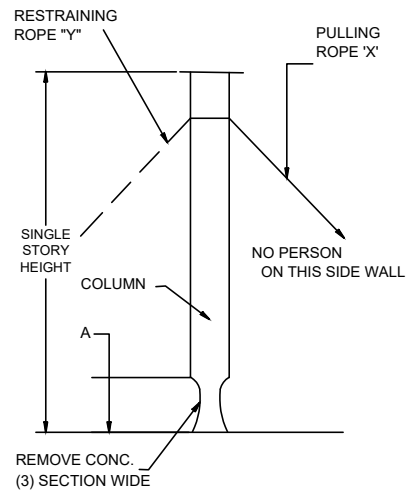

FIG. 5 MANUAL DEMOLITION OF IN-SITU CONCRETE STRUCTURE

### 16.9 Precast Units Stressed Separately

Before breaking up precast units stressed separately from the main frames of the structure, they should be lowered to the ground, if possible. It is advisable to seek the counsel of a professional engineer before carrying out this work, especially where there are ungrouted tendons. In general, this is true because grouting is not always 100 percent efficient. The following shall be noted before such kind of demolition:

- a) After lowering, units can be turned on their side with the ends up on blocks after any composite concrete is removed. This may suffice to break the unit and release the prestress; if not, erect a sand bag screen, timbers, or a blast mat as a screen around the ends;
- b) Clear the area of any personnel; and
- c) Remember the end blocks may be heavily reinforced and difficult to break up.

### 16.10 Monolithic Structures

A monolithic structure is something carved or cast from a single piece of a material. Usually (and literally, from the translation of monolith being 'one stone') the material is stone, but it could equally be applied to a structure cut from a single block of metal or cast in metal in a single piece. Most domed structures, like sports stadiums, are considered monolithic.

The advice of the professional engineer experienced in pre-stressed work should be sought before any attempt is made to expose the tendons or anchorages of structures in which two or more members have been stressed together. The following shall be noted before such kind of demolition:

- a) It will usually be necessary to provide temporary supports so that the tendons and the anchorage can be cautiously exposed; and
- b) Do not indiscriminately attempt to expose and de-stress the tendons and anchorages.

### 16.11 Chimney and Spires

**16.11.1** Before commencing of the demolition work,

involving such structures, advice of an engineer expert in such demolition shall be obtained and followed.

**16.11.2** The following shall be considered at the time of demolition of tall chimneys:

- a) Tall chimneys should not be demolished by blasting or overturning unless a protected area of adequate dimensions can be established in which the chimney can fall safely;
- b) Tall chimneys should only be demolished by competent persons under constant competent supervision.
- c) Workers should not stand on top of the chimney wall; and
- d) Material thrown down should only be removed during breaks in the work or under controlled conditions.

## 17 BLASTING METHODS

### 17.1 General Principles of Blasting Methods

Usually, concrete blasting is done using small confined explosive charges which are placed in drilling holes. Single, double or triple rows are used in the case of linear cuts of a structure or the demolition of columns, beams, walls, etc. If the demolition purpose is to create total fragmentation in the concrete or part of the structure, for instance when blasting foundations, apartments, opening, etc. The procedure is to arrange a pattern of holes in a grid with equal distance between the holes.

The explosive charges are normally ignited by millisecond delay detonators (generally time of delay is a multiple of 20 milliseconds to 30 milliseconds) and special consideration is paid to the safety, if the surroundings and remaining structure, just as the optimal use of the explosive energy is ensured.

Calculation of blasting charges have always been based on empiric formula and the personal experience of the individual blaster. A basic starting point for charge calculation is to determine the average specific charge for the object. The [Table 1](#) shows an example of empiric specific charges.

**Table 1 Empiric Specific Charges**(Clause [17.1](#))

SI No.	Object	Specific Charge (kg/m <sup>3</sup> )	Hole Spacing (m)
(1)	(2)	(3)	(4)
i)	Concrete and masonry, poor quality	0.15 to 0.40	0.70 to 0.80
ii)	Concrete and masonry, good quality	0.30 to 0.40	0.60 to 0.70
iii)	Reinforced concrete, normal	0.40 to 0.60	0.40 to 0.50
iv)	Reinforced concrete, heavy	0.60 to 1.50	0.30 to 0.50
v)	Reinforced concrete, heavy, high, concrete strength	1.50 to 2.00	0.25 to 0.50

**17.2 Controlled Blasting**

Controlled or careful blasting of concrete is a technique which is based on the same principles as modern rock blasting, using a minimum of explosives, to control the unwanted effect of the explosives and to prevent damage to the surroundings.

The control of blasting operations is made possible by using divided charges in densely drilled holes ignited at short time intervals normally 20 milliseconds to 30 milliseconds. The desired definitive effect can hereby be obtained and unintended effects reduced.

**17.3 Implosion**

Implosion, a specialized demolition technique employed for tall structures, involves strategically placing explosives at predetermined locations within the building. These explosives are then carefully detonated in a meticulously designed sequence, ensuring precise control over the direction of the collapse and its impact on the ground.

This method of demolition shall be carried out exclusively by experts well versed in the intricacies of explosives and structural dynamics.

**17.4** In general ground vibration during implosion shall be restricted to peak particle velocity (PPV) to less than 25 mm/s to adjacent structure closest to the structure being demolished.

**18 ENVIRONMENT MANAGEMENT**

Demolition activity can create impact to environment in different manner which could be managed by assessing and taking adequate precautionary measures as follows:

- Control of noise at the site boundaries;
- Control of dust emissions;
- Waste management;
- Minimizing of materials haulage;

- Bunding arrangements for storage and dispensing of fuel oils;
- Wheel washing plant and road-cleaning arrangements, where required;
- Skip or truck sheeting arrangements;
- Arrangements for dealing with hazardous materials, that is Flammable materials; gases, hazardous liquids and asbestos;
- Anticipated values of air overpressure and ground vibration;
- Areas of conservation, including flora and fauna; and
- Minimizing landfill.

**19 WEATHER CONDITIONS**

Weather forecast shall be obtained from Meteorological Department to have prior information on extreme weather conditions, and sudden and severe changes such as strong winds, lightning, snow and heavy rain, etc. The work programme shall be planned accordingly to the changing weather condition.

**20 RISK MANAGEMENT**

A detailed Hazard Identification and Risk Assessment (HIRA) shall be carried out before starting the activity to identify hazards associated with the demolition process, assess such hazards, and take reasonably practicable steps to eliminate or control the risks arising from those hazards.

Hazard Identification and Risk Assessment involves a five step risk assessment process as detailed below.

**20.1 Identifying the Hazards**

The first step in the risk management process is to identify the hazards associated with demolition work. Examples of demolition hazards include:

- Unplanned structure collapse;
- Fall of person from one level to another;

- c) Falling objects;
- d) The location of above ground and underground essential services, including the supply of gas, water, sewerage, telecommunications, electricity, chemicals, fuel and refrigerant in pipes or lines;
- e) Exposure to hazardous chemicals — these may be present in demolished material or in the ground where demolition work is to be carried out (contaminated sites);
- f) Hazardous noise from plant and explosives used in demolition work; and
- g) The proximity of the building or structure being demolished to other buildings or structures.

assessing the risk:

- a) Identify the hazards associated with the proposed work;
- b) Consider who might be harmed and how, including workers, site visitors, members of the public and anyone could be affected by the work;
- c) Evaluate the risks and identify the precautions required by, for example, comparison with good practice and categorization of risk level (likelihood and severity);
- d) Record the findings and implement the control measures for the residual risks; and
- e) Review the risk assessment and update if necessary. All the control measures to be practised as per the risk assessment should be communicated to workmen involved in the activities.

**20.2 Assessing Risk**

The following sequence shall be followed while

**20.3 Hierarchy of Risk Control**

While identifying the risk control adopt the hierarchy of risk control as per IS/ISO 45001. Examples of the risk controls as per the hierarchy is given in table below:

Hierarchy	Risk Control
Elimination	Always aim to eliminate the hazards, utilizing the most effective control measures if this is not reasonably practicable, the risk shall be minimized by adopting the other methods as follows.
Substitution	Using a mechanical demolition method by selecting appropriate machinery like demolition hammer, balling machine or hydraulic pusher arm which is suitable and safer than a manual method.
Engineering control	Use concrete barriers to separate pedestrians and powered mobile plant to reduce the risk of collision.  Fitting an open cab excavator with a falling objects protective structure to minimise the risk of being struck by a falling object.  Go for implosion in case of carrying out demolition work in urban area.
Administrative control	Take so far as is reasonably practicable control measures like installing warning signs and establish an exclusion zone around the demolition work.
Personal protective equipment	It shall be ensured that the workers are provided with adequate PPE and are wearing the same appropriately while they are involved in demolition activity.  <b><u>Mandatory Personal Protective Equipment</u></b>  Head protection — Safety helmet as per IS 2925 Reflective vest — Reflective jacket as per IS 15809 Foot protection — Safety shoes as per IS 15298  <b><u>Activity Specific Personal Protective Equipment</u></b>  a) Eye and face protection b) Respiratory protection c) Hearing protection d) Fall arresting equipment including full body harness and fall arrestors

## 21 COMPETENCIES AND TRAINING

**21.1** All demolition and structural alteration activities should be carefully planned and carried out by contractor having previous experience and competency. Clients have a key role and should ensure that all contractors, designers and other team members have either the competence to carry out the work themselves or have engaged the services of an individual or organization with these competencies.

**21.2** Management of the contracting company should ensure that the necessary levels of competency exist with their work. Competency of their employees in the capability of managers, supervisors and workmen engaged for demolition are maintained at the level of experience have received suitable training from industry recognized training institutions.

**21.3** Training facilitated to the persons involved in demolition activity shall cover the below topics:

- a) Asbestos, lead and silica awareness and removal;
- b) Oxygen/fuel cutting;
- c) Scaffolding;
- d) Working at height;
- e) Material handling;
- f) Demolition supervisor course;
- g) Abrasive grinding;
- h) Powered industrial truck operations;
- j) Blasting operations; and
- k) Personal protective equipment.

## 22 PERMIT TO WORK PROCEDURE

The contractor shall issue a permit to work to any employee, likely to be exposed to hazardous work processes or hazardous working environment to secure the safety and health of the employee. Such work and workplace environment that may require permit to work, shall ensure:

- a) Trained and competent workmen;
- b) Floors free from danger of overload;
- c) Protection to pedestrian;
- d) Availability of sufficient fire extinguishers;
- e) Availability of first-aid kit; and
- f) Electrical equipment with test certificates and proper earth connections.

## 23 EMERGENCY ARRANGEMENTS

Emergency arrangements should be put in place before demolition activity. The following shall be

provided, as appropriate:

- a) Artificial resuscitator;
- b) Stretchers;
- c) Emergency lights and torch lights;
- d) Rescue and resuscitation equipment;
- e) Measures for raising the alarm and rescue;
- f) Measures for safeguarding the rescuers;
- g) Fire Extinguishers;
- h) First aid kit;
- j) Public emergency services; and
- k) Effective communication arrangement.

## 24 CONTROLLING ASBESTOS HAZARDS

Presence of asbestos impregnated material in the demolishing structures shall be hazardous and harmful to health because the airborne asbestos fibres when inhaled cause serious health issue.

Airborne levels of asbestos are never to exceed legal worker exposure limits. There is really no 'safe' level of asbestos exposure for any type of asbestos fibres. Asbestos exposures, as short in duration as a few days have caused mesothelioma in humans. Every occupational exposure to asbestos can cause injury or asbestos-related disease.

- a) Where there is exposure, employers are required to further protect workers by establishing regulated areas, controlling certain work practices and instituting engineering controls to reduce the airborne levels;
- b) The employer is required to ensure exposure is reduced by using administrative controls and provide for the wearing of personal protective equipment; and
- c) Medical monitoring of workers is also required when legal limits and exposure times are exceeded.

## 25 CONTROLLING SILICA EXPOSURE

To control exposure to silica dust and fibres emitted out of demolition activity, avoid dry sweeping and the use of compressed air on concrete. Both these activities can stir up large amounts of dust. Use a vacuum with high efficiency filters when possible. When these activities cannot be avoided, respirators must be worn.

Best practices to help protect employees against exposures to silica include:

- a) Replace crystalline silica materials with

- safer substitutes, whenever possible;
- b) Provide engineering or administrative controls, where feasible, such as local exhaust ventilation and blasting cabinets. Where necessary to reduce exposures below the PEL, use protective equipment or other protective measures;
  - c) Use all available work practices to control dust exposures, such as water sprays; and
  - d) Wear only a N95 certified respirator, if respirator protection is required. Do not

alter the respirator. Do not wear a tight-fitting respirator with a beard or moustache that prevents a good seal between the respirator and the face.

## **26 SAFETY SIGNAGES**

All demolition sites should display safety signages at appropriate locations. The signages should be visible from a minimum distance of 6 m. A list of suggested signages is attached in the [Annex D](#).

## ANNEX A

*(Clause 2)*

## LIST OF REFERRED STANDARDS

<i>IS No.</i>	<i>Title</i>	<i>IS No.</i>	<i>Title</i>
IS 2190 : 2010	Selection, installation and maintenance of first-aid fire extinguishers — Code of practice ( <i>fourth revision</i> )	IS 15298 (Part 2) : 2016/ISO 20345 : 2011	Personal protective equipment: Part 2 safety footwear ( <i>second revision</i> )
IS 2925 : 1984	Specification for industrial safety helmets ( <i>second revision</i> )	IS 15809 : 2017	High visibility warning clothes — Specification ( <i>first revision</i> )
IS 3696 (Part 2) : 1991	Scaffolds and ladders — Code of safety: Part 2 Ladders ( <i>first revision</i> )	IS15883 (Part 5) : 2013	Construction project management — Guidelines: Part 5 Health and safety management
IS 7293 : 1974	Safety code for working with construction machinery	IS/ISO 45001 : 2018	Occupational health and safety management systems — Requirements with guidance for use ( <i>second revision</i> )
IS 13416 (Part 3) : 1994	Preventive measures against hazards at workplaces — Recommendations: Part 3 Disposal of debris		

access Indian Standards click on the link below:

[https://www.services.bis.gov.in/php/BIS\\_2.0/bisconnect/knowyourstandards/Indian\\_standards/isdetails/](https://www.services.bis.gov.in/php/BIS_2.0/bisconnect/knowyourstandards/Indian_standards/isdetails/)

**ANNEX B**

*(Foreword)*

**LIST OF DEMOLITION METHODOLOGIES**

- a) Manual demolition (sledge hammer)
- b) Manual chipping (hand held chippers)
- c) Tractor powered pneumatic breaker
- d) Backhoe/Excavator attachments:
  - 1) Hydraulic breaker
  - 2) Hydraulic drum cutter
  - 3) Hydraulic concrete crusher
  - 4) Hydraulic steel scrap shear
  - 5) Hydraulic drum cutter
- e) Diamond cutting methods:
  - 1) Floor sawing
  - 2) Wall sawing
  - 3) Wire Sawing
  - 4) Core Drilling
- f) Mechanical splitters and busters
- g) Chemical bursting agents
- h) Crane and ball method
- j) Explosive demolition (implosion)
- k) Thermic lancing
- m) Robotic demolition
- n) High impact hammer
- p) Hydro-demolition using high pressure water jet.
- q) Mechanical pull down method (mainly for steel structures)
- r) Oxy acetylene cutting of steel structures
- s) Specialised methods/equipment:
  - 1) Drive Breaker (For Chimneys and Cooling Towers)
  - 2) Multi Head drive breaker (For Concrete pavements)
  - 3) High Impact Drive Breaker (For pavements)



## ANNEX C

*(Foreword)*

## GENERAL CHECKLIST

SI No.	Item	Done	Not Done	Not Required
i)	Prior to initiating demolition activities, the demolition plan to be approved by competent authority or by a registered professional engineer.			
ii)	Has an engineering survey by a registered professional engineer, of the structure been done.			
iii)	Have all electric, gas, water, steam, sewer, and other service lines been shut off, capped or otherwise controlled outside the building line before demolition is started.			
iv)	Have the proper personnel been notified to remove all hazardous material (lead, asbestos, etc).			
v)	Has contractor provided engineering drawings that indicate the location of all services lines and the means for their control.			
vi)	Has it been determined if any hazardous building materials, hazardous chemicals, gases, explosives, flammable materials, or dangerous substances have been used in any building construction, pipes, tanks, or other equipment on the property.			
vii)	When employees work within a structure to be demolished that has been damaged by fire, flood, explosion, or other cause, have the floors and walls been shored or braced.			
viii)	Has each story of exterior wall and floor construction been removed and dropped into the storage space below before commencing the removal of exterior walls and floors in the next story below.			
ix)	Have the entrances for employees to multi-storey structures being demolished been protected by sidewalk sheds, canopies, or both.			
x)	Is the designated means of access indicated on the demolition plan.			
xi)	Are continuing inspections by a competent person being made during demolition to detect hazards resulting from weakened or deteriorated floors, walls or loosened material.			
xii)	Are chute openings into which debris is dumped protected by a guardrail 100 cm above the floor or other surface on which personnel stand to dump the material.			
xiii)	Are signs warning of the hazard of falling materials posted at each side of the debris opening at each floor.			
xiv)	Are employees prohibited from working on the top of a wall during hazardous weather.			
xv)	Is there a Construction and Demolition waste management plan in place and competent authorities notified.			
<b>HEAVY EQUIPMENT/MOTOR VEHICLES</b>				
i)	Is heavy equipment/motor vehicles inspecting each day prior to use and receive maintenance and servicing when needed.			

(Continued)

SI No.	Item	Done	Not Done	Not Required
ii)	Are flagmen available where ever needed.			
iii)	Are state and local vehicle regulations observed.			
iv)	Are weight limits and load sizes observed.			
v)	As an administrative control, safety signages, caution boards shall be displayed at all the conspicuous locations of work location.			
vi)	Are only trained operators deployed for operating heavy equipment.			
vii)	Are only approved containers and portable tanks were used for storage and handling of flammable liquids.			
viii)	Are bulk containers of flammable liquids bonded and grounded during dispensing.			
ix)	Are containers of flammable gases and liquids clearly identified.			
x)	Are fire hazards checked during and after hours of inspection.			
xi)	Are flammable gases and liquids properly stored in fire rated cabinets.			
<b>PREPLANNING AND PRECAUTIONS BEFORE STARTING DEMOLITION WORK</b>				
i)	Prior to permitting employees to start demolition operations, an engineering survey of structures/buildings/equipment shall be made by our competent team, to determine structural integrity and the possibility of unplanned collapse of any portion of the structure/building/ equipment. All adjacent structures where employees may be exposed shall also be similarly checked. The employer shall have in writing, evidence that such a survey has been performed.			
ii)	Ensure that proper document/letter is available for demolition of a building/structure/equipment, etc, schematic sketches for the key plan and elevations showing the different buildings/structures/equipment etc, to be demolished, are to be prepared. Necessary documents are to be prepared.			
iii)	Adequacy and stability of parts to be demolished/retained, are to be ensured. A definite plan of procedure for the demolition work shall be prepared by contractor/consultants and finalized in consultation with the executing department/supervising department/supervising agency. A copy of the survey report and of the plans and/or methods of operations shall be maintained at the job site for the duration of the demolition operation.			
iv)	Before demolition work is started, glazed sash, glazed doors and windows, etc, shall be removed. All fragile and loose fixtures shall be removed. The lath and all loose plaster shall be stripped off throughout the entire building. This is advantageous because it reduces glass breakage and also eliminates a large amount of dust producing material before more substantial parts of the buildings are removed.			
<b>PLANNING</b>				
i)	Before beginning the actual work of demolition, a careful study shall be made of the structure which is to be pulled down and also of all its surroundings. This shall be in particular, include study of the manner in which the various parts of the building to be			

(Continued)

SI No.	Item	Done	Not Done	Not Required
	demolished are supported and how far the stage-by-stage demolition will affect the safety of the adjoining structure. A definite plan of procedure for the demolition work, depending upon the manner in which the loads of the various structural parts are supported, shall be prepared and approved by the engineer-in-charge and this shall be followed as closely as possible, in actual execution of the demolition work. Before the commencement of each stage of demolition, the foreman shall brief the workmen in detail regarding the safety aspects to be kept in view.			
ii)	All gas, water steam and other service lines shall be shut off and capped or otherwise controlled at or outside the building line, before demolition work is started.			
<b>PROTECTION OF THE PUBLIC</b>				
i)	Before any demolition work is started, every sidewalk or road adjacent to the work likely to be affected shall be closed or protected.			
ii)	Green cloth will be wrapped around the building to control dust, debris, blocks, bricks, glass or electrical sparks from falling near the demolition area.			
iii)	Deploy high-capacity dust suppression machine for the dust control			
iv)	Display of emergency evacuation plan, contact numbers and warning signage's			
<b>BASIC TECHNICAL AND OTHER REQUIREMENTS</b>				
i)	The equipment to be used for the work, including the size, type, position and coverage of proposed demolition High reach excavators, crane shall be indicated on a site plan.			
ii)	The provision of clear instructions for temporary bracing/ stays and propping etc.			
iii)	Ensure that the ground is compacted to any design specifications to enable plant to be moved and used safely at the workplace.			
iv)	A supported scaffolding gantry should be installed to prevent inadvertent collapse during demolition.			
<b>SAFE WORK PROCEDURE FOR DEMOLITION AND DISMANTLING</b>				
i)	All works will be the subject of task and continuous risk assessments according to edifice standards.			
ii)	Ensuring the energies, Isolation and barricading of actual work site location.			
iii)	On every demolition job, danger signs shall be conspicuously posted all around the structure and all doors and openings giving access to the structure shall be kept barricaded or manned except during the actual passage of workmen or equipment. However, provision shall be made for at least two independent exits for escape of workmen during any emergency.			
iv)	All tools and tackles should have valid test certificate as per statutory norms for all the equipment engaged for demolition job.			
v)	Risk to health and adequate control measures to be taken in case			

SI No.	Item	Done	Not Done	Not Required
	of use of Hazardous substances for example, hydraulic oil, diesel, gases (oxygen/etc).			
vi)	Personal protective equipment (PPEs) to be used.			
vii)	Availability of movable hard barricading and soft barricading with warning signage's.			
viii)	Predefined pathway for vehicular and machinery movement with traffic marshals.			
ix)	Availability water supply for dust suppression and decontamination purpose.			
x)	Ensure daily tool box talk and work permit system.			
xi)	Follow the approved dismantling sequence.			
xii)	Ensure daily checklist of machineries on site.			
xiii)	Availability of MSDS of chemicals near work area.			
xiv)	Ensure isolation of flammables from work area during hot work and monitoring of hazardous gases during hot work using multi gas detectors.			
xv)	Availability of portable fire fighting equipment and identification of nearby hydrant points.			
xvi)	Hard and soft barricading to avoid unauthorised entry continuous work monitoring.			
xvii)	Clear responsibility to be given: executing authority to be designated.			
xviii)	Technical content of the job should be taken care.			
xix)	Disposal of demolished debris and scrap as per instruction of the executing authority.			

NOTE — This list is only indicative and can be modified based on different demolition processes.

ANNEX D

(Foreword and Clause 26)

SAFETY SIGNAGES

 <p><b>WARNING</b> <b>Explosive materials.</b> Unauthorized persons keep out.</p>	 <p><b>WARNING</b> <b>FALL HAZARD</b></p>
 <p><b>Warning</b> People working overhead</p>	 <p>Fire assembly point</p>
 <p><b>WARNING</b></p>	 <p><b>CAUTION</b> <b>HEAVY EQUIPMENT IN OPERATION</b></p>
	

## ANNEX E

(Foreword)

## COMMITTEE COMPOSITION

## Safety in Construction Sectional Committee, CED 45

<i>Organization</i>	<i>Representative(s)</i>
In Personal Capacity (132, Marigold Serene County, Telecom Nagar, Gachibouuli, Hyderabad)	SHRI M. P. NAIDU ( <b>Chairperson</b> )
AECOM India Private Limited, Gurugram	SHRI GOVINDRAJ M.
Advanced Construction Technologies Private Limited, Chennai	SHRI MOHAN RAMANATHAN
Builders Association of India, Mumbai	REPRESENTATIVE
Central Public Works Department, New Delhi	SHRI SATYA NARAIN JAISWAL SHRI CHANDRA SHEKHAR AZAD ( <i>Alternate</i> )
Centre for Workplace Safety and Health, Mysuru	DR N. C. BALAJI DR GOURAV K. ( <i>Alternate</i> )
CSIR – Central Building Research Institute, Roorkee	DR SUBHASH CHAND BOSE GURRAM DR RAJESH DEOLIA ( <i>Alternate</i> )
CSIR – Central Road Research Institute, New Delhi	SHRI G. K. SAHU DR RAJEEV GOEL ( <i>Alternate</i> )
Delhi Development Authority, New Delhi	SHRI D. C. GOEL
Delhi Metro Rail Corporation Limited, Delhi	SHRI DEVENDRA GILL
EHS Cares, New Delhi	SHRI A. K. TRIPATHI SHRI ANOOP PANDEY ( <i>Alternate</i> )
Engineers India Limited, Gurugram	SHRI RAVINDRA KUMAR SHRI DEBASISH GHOSAL ( <i>Alternate</i> )
Hilti India Private Limited, New Delhi	SHRI SHOUNAK MITRA
Indian Building Congress, New Delhi	REPRESENTATIVE
Indian Institute of Technology Madras, Chennai	SHRI NIKHIL BUGALIA
L&T Limited, Chennai	DR K. N. SEN SHRI M. NACHIAPPAN ( <i>Alternate</i> )
National Institute of Construction Management and Research, Pune	DR ANIL KASHYAP SHRI S. V. S RAJAPRASAD ( <i>Alternate</i> )
National Safety Council, Navi Mumbai	SHRI R. R. DEOGHARE SHRI SWAPNIL U. PUPULWAD ( <i>Alternate</i> )
NBCC (India) Limited, New Delhi	REPRESENTATIVE

<i>Organization</i>	<i>Representative(s)</i>
NTPC Limited, New Delhi	SHRI PALASH CHAKRABORTTY MS LINDA SKARIAH ( <i>Alternate</i> )
STUP Consultants Private Limited, Mumbai	SHRI ANBU THOMAS SAMUEL SHRI YOGESH GOPINATH ( <i>Alternate</i> )
TATA Projects Limited, Noida	SHRI YOGESH SARAN SRIVASTAVA
The Institution of Engineers (India), Kolkata	SHRI S. K. SINGH
In Personal Capacity (204, Sector-A Pocket C Vasant Kunj, New Delhi)	DR VANITA AHUJA
In Personal Capacity (8A/60, W. E. A. Karol Bagh New Delhi)	SHRI ANIL KAPOOR
In Personal Capacity (4581, Gomathi, Ganesa Temple Road, N. R. Mohalla, Mysuru)	PROF N. KRISHNAMURTHY
In Personal Capacity (Grace Villa, Kadamankulam, P.O, Thiruvalla)	SHRI JOSE KURIAN
In Personal Capacity (F-29, Flat P1/02 Block 2 Silver Estate, Sector 50, Noida)	SHRI VINOD NAKRA
In Personal Capacity (B-31, Manas Apartments, Mayur Vihar Phase-1, Delhi)	SHRI V. K. SHARMA
BIS Directorate General	SHRI ARUNKUMAR S., SCIENTIST 'E'/DIRECTOR AND HEAD (CIVIL ENGINEERING) [REPRESENTING DIRECTOR GENERAL ( <i>Ex-officio</i> )]

*Member Secretary*  
SHRI PRASHANT YADAV  
SCIENTIST 'B'/ASSISTANT DIRECTOR  
(CIVIL ENGINEERING), BIS





## Bureau of Indian Standards

BIS is a statutory institution established under the *Bureau of Indian Standards Act, 2016* to promote harmonious development of the activities of standardization, marking and quality certification of goods and attending to connected matters in the country.

### Copyright

BIS has the copyright of all its publications. No part of these publications may be reproduced in any form without the prior permission in writing of BIS. This does not preclude the free use, in the course of implementing the standard, of necessary details, such as symbols and sizes, type or grade designations. Enquiries relating to copyright be addressed to the Head (Publication & Sales), BIS.

### Review of Indian Standards

Amendments are issued to standards as the need arises on the basis of comments. Standards are also reviewed periodically; a standard along with amendments is reaffirmed when such review indicates that no changes are needed; if the review indicates that changes are needed, it is taken up for revision. Users of Indian Standards should ascertain that they are in possession of the latest amendments or edition by referring to the website-[www.bis.gov.in](http://www.bis.gov.in) or [www.standardsbis.in](http://www.standardsbis.in).

This Indian Standard has been developed from Doc No.: CED 45 (22215).

### Amendments Issued Since Publication

Amend No.	Date of Issue	Text Affected

## BUREAU OF INDIAN STANDARDS

### Headquarters:

Manak Bhavan, 9 Bahadur Shah Zafar Marg, New Delhi 110002

Telephones: 2323 0131, 2323 3375, 2323 9402

Website: [www.bis.gov.in](http://www.bis.gov.in)

### Regional Offices:

	Telephones
Central : 601/A, Konnectus Tower -1, 6 <sup>th</sup> Floor, DMRC Building, Bhavbhuti Marg, New Delhi 110002	{ 2323 7617
Eastern : 8 <sup>th</sup> Floor, Plot No 7/7 & 7/8, CP Block, Sector V, Salt Lake, Kolkata, West Bengal 700091	{ 2367 0012 2320 9474
Northern : Plot No. 4-A, Sector 27-B, Madhya Marg, Chandigarh 160019	{ 265 9930
Southern : C.I.T. Campus, IV Cross Road, Taramani, Chennai 600113	{ 2254 1442 2254 1216
Western : Plot No. E-9, Road No.-8, MIDC, Andheri (East), Mumbai 400093	{ 2821 8093

**Branches :** AHMEDABAD. BENGALURU. BHOPAL. BHUBANESHWAR. CHANDIGARH. CHENNAI. COIMBATORE. DEHRADUN. DELHI. FARIDABAD. GHAZIABAD. GUWAHATI. HIMACHAL PRADESH. HUBLI. HYDERABAD. JAIPUR. JAMMU & KASHMIR. JAMSHEDPUR. KOCHI. KOLKATA. LUCKNOW. MADURAI. MUMBAI. NAGPUR. NOIDA. PANIPAT. PATNA. PUNE. RAIPUR. RAJKOT. SURAT. VISAKHAPATNAM.