

INTERNATIONAL STANDARD

**Liquid crystal display devices –
Part 40-3: Mechanical testing of display cover glass for mobile devices – Biaxial
flexural energy to failure (ball drop)**





THIS PUBLICATION IS COPYRIGHT PROTECTED

Copyright © 2015 IEC, Geneva, Switzerland

All rights reserved. Unless otherwise specified, no part of this publication may be reproduced or utilized in any form or by any means, electronic or mechanical, including photocopying and microfilm, without permission in writing from either IEC or IEC's member National Committee in the country of the requester. If you have any questions about IEC copyright or have an enquiry about obtaining additional rights to this publication, please contact the address below or your local IEC member National Committee for further information.

IEC Central Office
3, rue de Varembe
CH-1211 Geneva 20
Switzerland

Tel.: +41 22 919 02 11
Fax: +41 22 919 03 00
info@iec.ch
www.iec.ch

About the IEC

The International Electrotechnical Commission (IEC) is the leading global organization that prepares and publishes International Standards for all electrical, electronic and related technologies.

About IEC publications

The technical content of IEC publications is kept under constant review by the IEC. Please make sure that you have the latest edition, a corrigenda or an amendment might have been published.

IEC Catalogue - webstore.iec.ch/catalogue

The stand-alone application for consulting the entire bibliographical information on IEC International Standards, Technical Specifications, Technical Reports and other documents. Available for PC, Mac OS, Android Tablets and iPad.

IEC publications search - www.iec.ch/searchpub

The advanced search enables to find IEC publications by a variety of criteria (reference number, text, technical committee,...). It also gives information on projects, replaced and withdrawn publications.

IEC Just Published - webstore.iec.ch/justpublished

Stay up to date on all new IEC publications. Just Published details all new publications released. Available online and also once a month by email.

Electropedia - www.electropedia.org

The world's leading online dictionary of electronic and electrical terms containing more than 30 000 terms and definitions in English and French, with equivalent terms in 15 additional languages. Also known as the International Electrotechnical Vocabulary (IEV) online.

IEC Glossary - std.iec.ch/glossary

More than 60 000 electrotechnical terminology entries in English and French extracted from the Terms and Definitions clause of IEC publications issued since 2002. Some entries have been collected from earlier publications of IEC TC 37, 77, 86 and CISPR.

IEC Customer Service Centre - webstore.iec.ch/csc

If you wish to give us your feedback on this publication or need further assistance, please contact the Customer Service Centre: csc@iec.ch.



IEC 61747-40-3

Edition 1.0 2015-01

INTERNATIONAL STANDARD

**Liquid crystal display devices –
Part 40-3: Mechanical testing of display cover glass for mobile devices – Biaxial
flexural energy to failure (ball drop)**

INTERNATIONAL
ELECTROTECHNICAL
COMMISSION

ICS 31.120

ISBN 978-2-8322-2211-9

Warning! Make sure that you obtained this publication from an authorized distributor.

CONTENTS

FOREWORD	3
INTRODUCTION	5
1 Scope	6
2 Normative references	6
3 Terms and definitions	6
4 General	6
5 Apparatus	7
5.1 Testing environment and pre-conditioning	7
5.2 Apparatus overview	7
5.3 Height adjustment beam	8
5.4 Specimen holder	8
5.5 Armature	9
5.6 Ball release mechanism	10
5.7 Height adjustment clamp	10
5.8 Ball release controller	10
5.9 Ball	10
5.10 Base	10
6 Procedure	10
6.1 Safety	10
6.1.1 Hazard – Broken glass	10
6.1.2 Hazard – Compression due to moving ball	10
6.2 Sample	10
6.3 Individual specimen	11
6.4 Complete the report	11
7 Calculations	12
7.1 Breaking energy	12
7.2 Statistical calculations	12
8 Reporting	13
8.1 Information to be reported for each test	13
8.2 Information to be made available upon request	13
9 Specifications	14
Figure 1 – Apparatus overview	8
Figure 2 – Specimen holder (top view)	9
Figure 3 – Specimen holder (side view, cross-section)	9
Figure 4 – Example Weibull plot	13

INTERNATIONAL ELECTROTECHNICAL COMMISSION

LIQUID CRYSTAL DISPLAY DEVICES –

**Part 40-3: Mechanical testing of display cover glass for mobile devices –
Biaxial flexural energy to failure (ball drop)**

FOREWORD

- 1) The International Electrotechnical Commission (IEC) is a worldwide organization for standardization comprising all national electrotechnical committees (IEC National Committees). The object of IEC is to promote international co-operation on all questions concerning standardization in the electrical and electronic fields. To this end and in addition to other activities, IEC publishes International Standards, Technical Specifications, Technical Reports, Publicly Available Specifications (PAS) and Guides (hereafter referred to as “IEC Publication(s)”). Their preparation is entrusted to technical committees; any IEC National Committee interested in the subject dealt with may participate in this preparatory work. International, governmental and non-governmental organizations liaising with the IEC also participate in this preparation. IEC collaborates closely with the International Organization for Standardization (ISO) in accordance with conditions determined by agreement between the two organizations.
- 2) The formal decisions or agreements of IEC on technical matters express, as nearly as possible, an international consensus of opinion on the relevant subjects since each technical committee has representation from all interested IEC National Committees.
- 3) IEC Publications have the form of recommendations for international use and are accepted by IEC National Committees in that sense. While all reasonable efforts are made to ensure that the technical content of IEC Publications is accurate, IEC cannot be held responsible for the way in which they are used or for any misinterpretation by any end user.
- 4) In order to promote international uniformity, IEC National Committees undertake to apply IEC Publications transparently to the maximum extent possible in their national and regional publications. Any divergence between any IEC Publication and the corresponding national or regional publication shall be clearly indicated in the latter.
- 5) IEC itself does not provide any attestation of conformity. Independent certification bodies provide conformity assessment services and, in some areas, access to IEC marks of conformity. IEC is not responsible for any services carried out by independent certification bodies.
- 6) All users should ensure that they have the latest edition of this publication.
- 7) No liability shall attach to IEC or its directors, employees, servants or agents including individual experts and members of its technical committees and IEC National Committees for any personal injury, property damage or other damage of any nature whatsoever, whether direct or indirect, or for costs (including legal fees) and expenses arising out of the publication, use of, or reliance upon, this IEC Publication or any other IEC Publications.
- 8) Attention is drawn to the Normative references cited in this publication. Use of the referenced publications is indispensable for the correct application of this publication.
- 9) Attention is drawn to the possibility that some of the elements of this IEC Publication may be the subject of patent rights. IEC shall not be held responsible for identifying any or all such patent rights.

International Standard IEC 61747-40-3 has been prepared by technical committee 110: Electronic display devices.

The text of this standard is based on the following documents:

CDV	Report on voting
110/569/CDV	110/609A/RVC

Full information on the voting for the approval of this standard can be found in the report on voting indicated in the above table.

This publication has been drafted in accordance with the ISO/IEC Directives, Part 2.

A list of all parts in the IEC 61747 series, published under the general title *Liquid crystal display devices*, can be found on the IEC website.

The committee has decided that the contents of this publication will remain unchanged until the stability date indicated on the IEC web site under "<http://webstore.iec.ch>" in the data related to the specific publication. At this date, the publication will be

- reconfirmed,
- withdrawn,
- replaced by a revised edition, or
- amended.

A bilingual version of this publication may be issued at a later date.

INTRODUCTION

Mobile electronic devices have become increasingly sophisticated and often include displays for the purposes of user interface and viewing. Such displays commonly incorporate a transparent cover glass which aids in protecting the display against the introduction of damage through routine device transport and use, as well as occasional or accidental misuse.

The purpose of this standard is to provide mechanical testing procedures for cover glasses utilized in such applications. Such glasses can be strengthened, for example via an ion-exchange process, which acts to increase mechanical strength through the introduction of a surface compressive layer.

LIQUID CRYSTAL DISPLAY DEVICES –

Part 40-3: Mechanical testing of display cover glass for mobile devices – Biaxial flexural energy to failure (ball drop)

1 Scope

This part of IEC 61747-40 is a mechanical performance testing procedure for cover glass used in electronic flat panel displays in mobile devices. This standard is focused on the measurement of surface impact resistance via biaxial flexure generated by a ball drop.

2 Normative references

The following documents, in whole or in part, are normatively referenced in this document and are indispensable for its application. For dated references, only the edition cited applies. For undated references, the latest edition of the referenced document (including any amendments) applies.

IEC 61747-40-1, *Liquid crystal display devices – Part 40-1: Mechanical testing of display cover glass for mobile devices – Guidelines*

IEC 61649:2008, *Weibull analysis*

3 Terms and definitions

For the purposes of this document, the following terms and definitions apply.

3.1 specimen

individual piece of glass to be tested to failure

3.2 sample

group of specimens sharing a common pedigree (such as manufacturing process and period of production), for which failure statistics can be generated and reported

3.3 sample size

number of specimens in a sample

3.4 nominal value

value about which a tolerance range is specified

4 General

This test is statistical in nature. A ball is dropped onto each of a number of specimens in a sample. The energy required to break each specimen is recorded. Statistics that might be specified are calculated and reported. The energy required to break a given specimen is determined by starting with a minimum drop height and then increasing the drop height by a fixed increment for drops that do not result in breakage.

The typical energy required to break specimens will depend on the specimen nominal dimensions, length and width, as well as thickness. Sample breakage values should only be compared when the nominal dimensions of the samples are the same.

The combination of ball mass and dropping height yield the breakage energy. The apparatus allows for a maximum drop height of at least 180 cm. A ball mass of 128 g may be adequate for 50 mm × 50 mm ($\pm 0,5$ mm) specimens with thickness ranging from 0,55 mm to 2,0 mm. Thicker, stronger or larger specimens may require a larger ball for a 100 % breakage by a drop height of 180 cm.

Clause 5 describes the apparatus. Clause 6 describes the procedures for both the sample as a whole as well as for an individual specimen. Clause 7 describes the calculations.

To complete the test, some means of catching the ball when the ball drop does not break the specimen should be provided. This could be done by providing the tester with an assistant or by some apparatus. Possible apparatus options are not documented in this standard.

When the ball drop does not break the specimen and bounces, the rebound height may be up to approximately 80 % of the original drop height and is parallel to the height adjustment beam. When the drop results in breakage, the bounce direction is random but the rebound height is substantially reduced.

When breakage occurs due to a failure to catch the rebounding ball and a double impact results in breakage, the height is recorded, but the specimen is treated as a late suspension (see 7.2).

It is assumed that all measurements are performed by personnel skilled in the general art of mechanical property measurements. Furthermore, it should be assured that all equipment is suitably calibrated as is known to skilled personnel and that records of the calibration data and traceability are kept.

5 Apparatus

5.1 Testing environment and pre-conditioning

The standard testing environment is specified in 61747-40-1. Specimens shall be stored in such an environment for at least four hours before testing.

5.2 Apparatus overview

Figure 1 shows the overview of the apparatus.

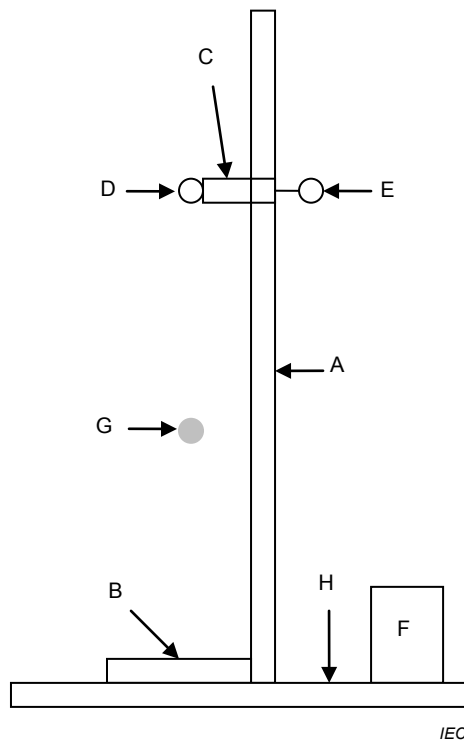

Key

- A Height adjustment beam
- B Specimen holder
- C Armature
- D Ball release mechanism
- E Height adjustment clamp
- F Ball release controller
- G Ball (while dropping)
- H Base

Figure 1 – Apparatus overview

5.3 Height adjustment beam

This beam shall be long enough to allow drops of at least 180 cm in maximum height. It is perpendicular to the testing surface. It shall be marked with distances from the test surface in increments of 5 cm. The test surface is the top surface of the specimen when it is inserted into the specimen holder. Drop distance is the distance from the test surface to the bottom of the ball when it is attached to the ball release mechanism.

To accommodate the possibility of different specimen thicknesses or specimen holder dimensions, a correction factor can be used to convert the height markings on the height adjustment beam to the actual dropping distances to within ± 1 mm before the energy calculation is completed.

5.4 Specimen holder

This is made of a rigidized polymer (such as polyoxymethylene (POM), high density polyethylene (HDPE), poly(methyl methacrylate) (PMMA), poly(methyl acrylate) (PMA) or polycarbonate (PC)) to minimize damage to specimens as they are mounted into it. It is a square or rectangular frame that supports a specimen on a ledge of 4 mm to 6 mm, with the ledge surrounded by a specimen containment barrier. The barrier dimension shall be large enough to accommodate all specimens without binding. The specimen shall be elevated from

the table by a distance that is large enough that no specimen touches the table due to deflection during a test.

Figure 2 shows a top view and Figure 3 shows a side view cross-section.

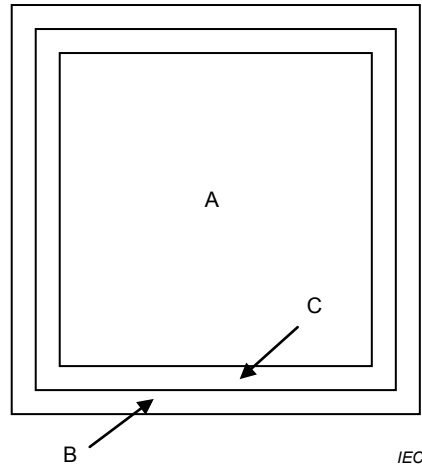

NOTE The key to the letters is provided in Figure 3.

Figure 2 – Specimen holder (top view)

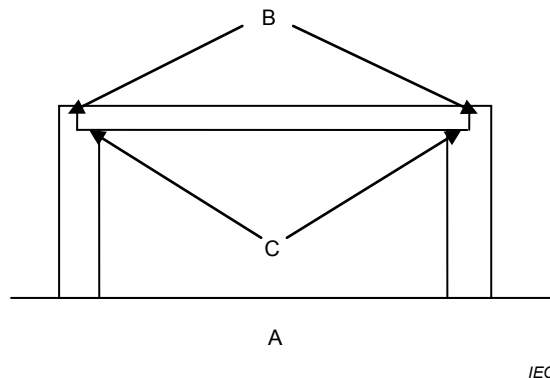

Key

- A Base surface
- B Specimen containment barrier
- C Ledge

Figure 3 – Specimen holder (side view, cross-section)

The specimen holder, base and/or height adjustment beam design shall provide a means of repeatability by placing the specimen holder so the ball drops onto the centre of the specimens. Displacement error from the intended drop location shall not be greater than 2 mm when performing drops ≤ 1 m in height and not greater than 3 mm when performing drops > 1 m in height. Displacement errors can be assessed via the use of a plumb line, a plumb bob and pressure-indicating films, or via other means which enable the accurate quantification of intended versus actual drop positions.

5.5 Armature

This connects the ball release mechanism to the height adjustment beam. It shall be perpendicular to the height adjustment beam.

5.6 Ball release mechanism

The ball holding and release mechanism shall either be electromagnetic or vacuum-assisted. This ensures free gravitational acceleration of the ball upon release.

Tethering or the use of a guide tube is not an acceptable means of ball release and/or guidance.

5.7 Height adjustment clamp

This holds the armature at a height that is indicated by the height adjustment beam while a ball is set and dropped from that height. The clamp is released following the ball drop to allow movement to a different height.

5.8 Ball release controller

The controller is an electronic switch with two states:

- 1) load and hold the ball,
- 2) release the ball.

5.9 Ball

The ball used for testing shall be produced from a steel alloy with Rockwell hardness of C60 to C67, and shall possess a reflective surface finish. The diameter tolerance shall be no greater than $\pm 0,05$ mm from nominal, and the deviation from sphericity shall be no greater than 0,025 mm.

Ball mass shall be within $\pm 2,0$ % of the specified value, and the actual (measured) mass shall be used for all energy calculations.

5.10 Base

The base shall be rigid and fully supported to ensure minimal energy absorption by the structure. Absorption of energy by the base can lead to variation in the energy applied to the specimen.

6 Procedure

6.1 Safety

6.1.1 Hazard – Broken glass

Wear safety glasses with side panels at all times. Wear gloves when handling broken glass.

6.1.2 Hazard – Compression due to moving ball

As previously noted, ball drop and rebound energies may be substantial and ball travel may be erratic. Care should be taken to ensure that all operators, assistants and persons in the area are alert and wearing appropriate personal protective equipment.

6.2 Sample

The sample size is 30, excluding any specimens rejected for pre-existing damage. Failures associated with breakage upon double bounce are included in the sample, but the values are treated as late suspensions (see 7.2). Specimens that fail from their edge, and those that do not fail at the maximum dropping height are also treated as late suspensions. If there are more than 10 suspensions, the testing fails and a new sample should be selected. If this occurs due to a high proportion of edge failures, actions may be taken to increase specimen

edge strength or to perform an alternate surface strength test such as a biaxial flexural strength via ring-on-ring.

Upon receipt of a new sample, the following steps shall be taken:

- a) Determine and record the following information:
 - sample identification,
 - sample specimen nominal dimensions: length, width, thickness,
 - requesting person,
 - determine whether existing test fixtures are compatible. If not, change them.
- b) Record the fixture dimensions or identification number.
- c) Determine whether a height adjustment factor is needed. This could be due to testing specimens with a different thickness than the thickness used to design the height adjustment beam or due to a different specimen holder than that used in the design.
- d) Thoroughly clean the testing area.

6.3 Individual specimen

Complete the following steps on each specimen of the sample. The working surfaces should be clean and free of anything that can induce damage. Application of the polymeric adhesive tape is intended to preserve the fracture surface and to reduce the scattering of glass fragments upon breakage.

- a) Determine and record the specimen identification number.
- b) Inspect for any damage. If damaged, report this, but do not include in the testing.
- c) Cut a section of polymeric adhesive tape that can cover the specimen and place it sticky side up on the working surface.
- d) Gently attach one edge of the specimen to one end of the tape.
- e) Gently lower the rest of the specimen onto the rest of the tape.
- f) Carefully trim the excess tape away from the specimen.
- g) Place the specimen in the test holder with the polymeric adhesive tape side facing downward.
- h) Set the armature for a 15 cm ball drop.
- i) Repeat the following for each drop:
 - 1) Load the ball.
 - 2) Drop the ball.
 - 3) If no breakage, catch the ball. If there is no initial breakage but the ball is not caught and the second impact results in breakage, the height is reported, but the specimen is marked as suspended.
 - 4) If no breakage, check that the sample remains correctly positioned within the fixture and move the armature up 5 cm and repeat 1) to 4).
- j) At this point, breakage occurred or the maximum height has been reached without breakage. Record the height and note whether the specimen should be suspended due to edge failure. If the height is maximum without breakage, also note the specimen as a suspension.
- k) Regain possession of the ball and thoroughly clean the area.

6.4 Complete the report

The calculations will normally be done by computer:

- a) Enter the sample identification and dimensions.

- b) Complete the breakage energy calculations of 7.1.
- c) Complete the Weibull analysis of 7.2.
- d) Print the report.

7 Calculations

7.1 Breaking energy

The breaking energy, E , in units of Joules, is given as equation (1).

$$E = \frac{m}{1\,000} g \frac{(h + c)}{100} \quad (1)$$

where

- m is the ball mass (g)
- h is the armature height (cm)
- c is a correction factor for specimen nominal thickness variation (cm)
- g is the gravitational acceleration factor = 9,81 m/s²

7.2 Statistical calculations

The Weibull analysis standard, IEC 61649, shall be used to calculate the following parameters:

- Weibull scale parameter, η (J)
- Weibull shape parameter, β
- the 10th percentile fracture energy, B_{10} (J)

The maximum likelihood estimate (MLE) method of calculation shall be used for the Weibull parameters. See 9.6 of IEC 61649:2008. The following equations are adapted from equations (17) and (18) of IEC 61649:2008 in order to accommodate suspensions as variable censoring.

Following the notation of IEC 61649, let t_i represent the valid fracture energy values, with $i=1$ to r , and let T_j represent the suspended values, with $j=1$ to s .

The shape parameter is the value of β that satisfies equation (2).

$$\frac{\sum_{i=1}^r t_i^\beta \ln t_i + \sum_{j=1}^s T_j^\beta \ln T_j}{\sum_{i=1}^r t_i^\beta + \sum_{j=1}^s T_j^\beta} - \frac{1}{\beta} - \frac{1}{r} \sum_{i=1}^r \ln t_i = 0 \quad (2)$$

Given this value for the shape parameter, the scale parameter is given as equation (3).

$$\eta = \left[\frac{1}{r} \left(\sum_{i=1}^r t_i^\beta + \sum_{j=1}^s T_j^\beta \right) \right]^{1/\beta} \quad (3)$$

The point estimate of the 10th percentile, B_{10} , is calculated using 9.8 of IEC 61649:2008 and equation (20) of IEC 61649:2008. Equation (20) is repeated here as equation (4) for

convenience. In Clause 9, this parameter is recommended to be specified for performance standards. It combines the scale and shape parameters to single, meaningful, metric.

$$B_{10} = \eta[-\ln(0,9)]^{1/\beta} \quad (4)$$

In addition to the calculation of statistical parameters, a Weibull plot is required (see 8.2). See 7.2.3 of IEC 61649:2008 for instructions on how to produce such a plot. An example Weibull plot is shown in Figure 4.

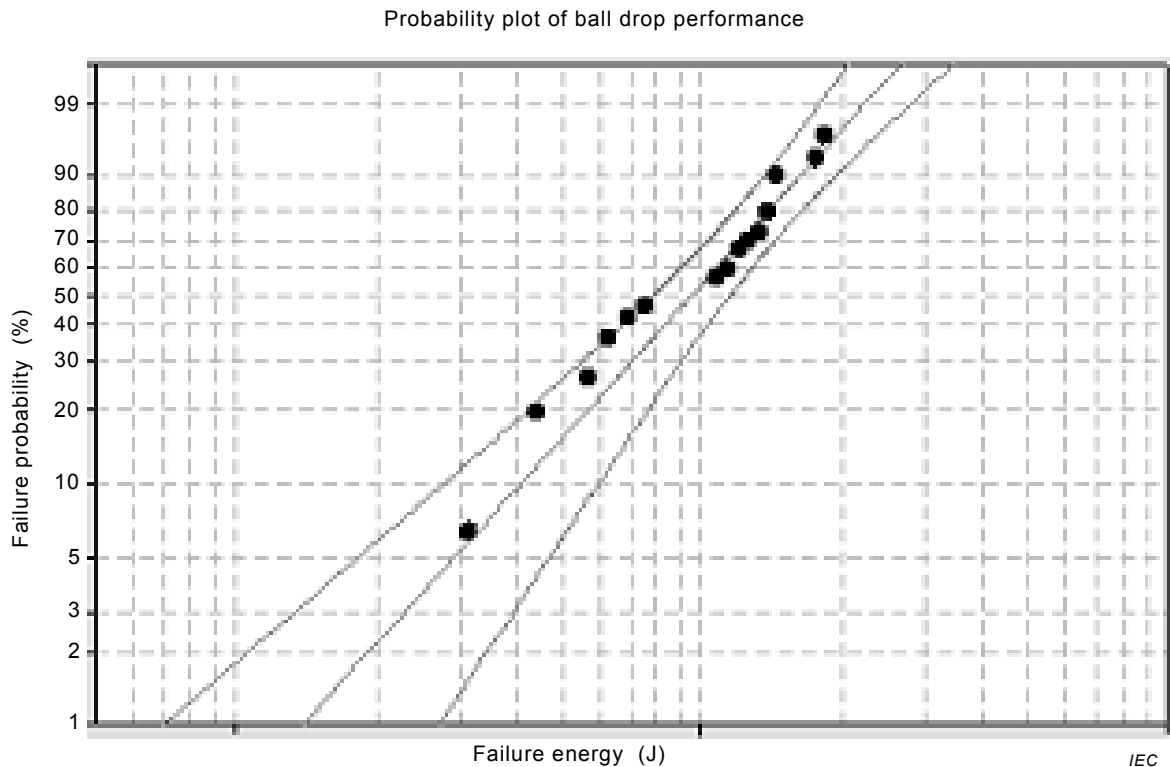

Figure 4 – Example Weibull plot

8 Reporting

8.1 Information to be reported for each test

Report the following for each test:

- Sample identification and nominal dimensions.
- Ball mass (g).
- Weibull scale parameter, η (J).
- Weibull shape parameter, β .
- Fracture energy 10th percentile, B_{10} (J).

8.2 Information to be made available upon request

The following information shall be available:

- All breakage energy values:

- Note suspensions and causes.
- Weibull plot.

9 Specifications

The following testing aspects require specification to obtain comparable results:

- Ball mass (g).
- Specimen nominal dimensions.
- Fixture dimensions.

The following parameter is recommended for specification in performance standards.

- The fracture energy 10th percentile, B_{10} (MPa).
-

INTERNATIONAL
ELECTROTECHNICAL
COMMISSION

3, rue de Varembé
PO Box 131
CH-1211 Geneva 20
Switzerland

Tel: + 41 22 919 02 11
Fax: + 41 22 919 03 00
info@iec.ch
www.iec.ch