

# INTERNATIONAL STANDARD

---

**Liquid crystal display devices –  
Part 40-2: Mechanical testing of display cover glass for mobile devices – Uni-  
axial flexural strength (4-point bend)**





## THIS PUBLICATION IS COPYRIGHT PROTECTED

Copyright © 2015 IEC, Geneva, Switzerland

All rights reserved. Unless otherwise specified, no part of this publication may be reproduced or utilized in any form or by any means, electronic or mechanical, including photocopying and microfilm, without permission in writing from either IEC or IEC's member National Committee in the country of the requester. If you have any questions about IEC copyright or have an enquiry about obtaining additional rights to this publication, please contact the address below or your local IEC member National Committee for further information.

IEC Central Office  
3, rue de Varembe  
CH-1211 Geneva 20  
Switzerland

Tel.: +41 22 919 02 11  
Fax: +41 22 919 03 00  
[info@iec.ch](mailto:info@iec.ch)  
[www.iec.ch](http://www.iec.ch)

### About the IEC

The International Electrotechnical Commission (IEC) is the leading global organization that prepares and publishes International Standards for all electrical, electronic and related technologies.

### About IEC publications

The technical content of IEC publications is kept under constant review by the IEC. Please make sure that you have the latest edition, a corrigenda or an amendment might have been published.

#### IEC Catalogue - [webstore.iec.ch/catalogue](http://webstore.iec.ch/catalogue)

The stand-alone application for consulting the entire bibliographical information on IEC International Standards, Technical Specifications, Technical Reports and other documents. Available for PC, Mac OS, Android Tablets and iPad.

#### IEC publications search - [www.iec.ch/searchpub](http://www.iec.ch/searchpub)

The advanced search enables to find IEC publications by a variety of criteria (reference number, text, technical committee,...). It also gives information on projects, replaced and withdrawn publications.

#### IEC Just Published - [webstore.iec.ch/justpublished](http://webstore.iec.ch/justpublished)

Stay up to date on all new IEC publications. Just Published details all new publications released. Available online and also once a month by email.

#### Electropedia - [www.electropedia.org](http://www.electropedia.org)

The world's leading online dictionary of electronic and electrical terms containing more than 30 000 terms and definitions in English and French, with equivalent terms in 15 additional languages. Also known as the International Electrotechnical Vocabulary (IEV) online.

#### IEC Glossary - [std.iec.ch/glossary](http://std.iec.ch/glossary)

More than 60 000 electrotechnical terminology entries in English and French extracted from the Terms and Definitions clause of IEC publications issued since 2002. Some entries have been collected from earlier publications of IEC TC 37, 77, 86 and CISPR.

#### IEC Customer Service Centre - [webstore.iec.ch/csc](http://webstore.iec.ch/csc)

If you wish to give us your feedback on this publication or need further assistance, please contact the Customer Service Centre: [csc@iec.ch](mailto:csc@iec.ch).



IEC 61747-40-2

Edition 1.0 2015-01

# INTERNATIONAL STANDARD

---

**Liquid crystal display devices –  
Part 40-2: Mechanical testing of display cover glass for mobile devices – Uni-  
axial flexural strength (4-point bend)**

INTERNATIONAL  
ELECTROTECHNICAL  
COMMISSION

---

ICS 31.120

ISBN 978-2-8322-2210-2

**Warning! Make sure that you obtained this publication from an authorized distributor.**

## CONTENTS

FOREWORD.....	3
INTRODUCTION.....	5
1 Scope.....	6
2 Normative references .....	6
3 Terms, definitions and abbreviations .....	6
3.1 Terms and definitions.....	6
3.2 Abbreviations .....	7
4 General .....	7
5 Apparatus.....	7
5.1 Testing environment and pre-conditioning.....	7
5.2 Testing frame.....	7
5.3 Test fixture and setup .....	9
5.4 Test fixture dimensions .....	12
5.5 Loading rate.....	13
6 Procedure.....	13
6.1 Safety .....	13
6.1.1 Hazard – Broken glass.....	13
6.1.2 Crush hazard – Only one person may operate the testing frame .....	13
6.1.3 Crush hazard – Take care when installing or removing a specimen .....	13
6.1.4 Hazard – Press the emergency stop button when an unsafe condition is observed .....	14
6.1.5 Flying debris hazard – Ensure that specimens are installed correctly.....	14
6.1.6 Hazard – Protect control cables from damage or disconnection .....	14
6.2 Sample .....	14
6.3 Individual specimen .....	14
6.4 Complete the report .....	16
7 Calculations.....	17
7.1 Strength calculations .....	17
7.2 Statistical calculations .....	17
8 Reporting.....	18
8.1 Information to be reported for each test .....	18
8.2 Information to be made available upon request.....	19
9 Specifications .....	19
Figure 1 – Testing frame.....	9
Figure 2 – Support assembly (side view).....	10
Figure 3 – Support assembly (top view) .....	10
Figure 4 – Load assembly (side view) .....	11
Figure 5 – Load assembly (bottom view) .....	11
Figure 6 – Example load traces for appropriate and inappropriate span settings .....	13
Figure 7 – Edge fracture originating from between the load bars .....	15
Figure 8 – Edge fracture originating from underneath the load bar .....	16
Figure 9 – Surface fracture originating from between the load bars.....	16
Figure 10 – Example Weibull plot.....	18

## INTERNATIONAL ELECTROTECHNICAL COMMISSION

## LIQUID CRYSTAL DISPLAY DEVICES –

**Part 40-2: Mechanical testing of display cover glass for mobile devices –  
Uni-axial flexural strength (4-point bend)**

## FOREWORD

- 1) The International Electrotechnical Commission (IEC) is a worldwide organization for standardization comprising all national electrotechnical committees (IEC National Committees). The object of IEC is to promote international co-operation on all questions concerning standardization in the electrical and electronic fields. To this end and in addition to other activities, IEC publishes International Standards, Technical Specifications, Technical Reports, Publicly Available Specifications (PAS) and Guides (hereafter referred to as “IEC Publication(s)”). Their preparation is entrusted to technical committees; any IEC National Committee interested in the subject dealt with may participate in this preparatory work. International, governmental and non-governmental organizations liaising with the IEC also participate in this preparation. IEC collaborates closely with the International Organization for Standardization (ISO) in accordance with conditions determined by agreement between the two organizations.
- 2) The formal decisions or agreements of IEC on technical matters express, as nearly as possible, an international consensus of opinion on the relevant subjects since each technical committee has representation from all interested IEC National Committees.
- 3) IEC Publications have the form of recommendations for international use and are accepted by IEC National Committees in that sense. While all reasonable efforts are made to ensure that the technical content of IEC Publications is accurate, IEC cannot be held responsible for the way in which they are used or for any misinterpretation by any end user.
- 4) In order to promote international uniformity, IEC National Committees undertake to apply IEC Publications transparently to the maximum extent possible in their national and regional publications. Any divergence between any IEC Publication and the corresponding national or regional publication shall be clearly indicated in the latter.
- 5) IEC itself does not provide any attestation of conformity. Independent certification bodies provide conformity assessment services and, in some areas, access to IEC marks of conformity. IEC is not responsible for any services carried out by independent certification bodies.
- 6) All users should ensure that they have the latest edition of this publication.
- 7) No liability shall attach to IEC or its directors, employees, servants or agents including individual experts and members of its technical committees and IEC National Committees for any personal injury, property damage or other damage of any nature whatsoever, whether direct or indirect, or for costs (including legal fees) and expenses arising out of the publication, use of, or reliance upon, this IEC Publication or any other IEC Publications.
- 8) Attention is drawn to the Normative references cited in this publication. Use of the referenced publications is indispensable for the correct application of this publication.
- 9) Attention is drawn to the possibility that some of the elements of this IEC Publication may be the subject of patent rights. IEC shall not be held responsible for identifying any or all such patent rights.

International Standard IEC 61747-40-2 has been prepared by technical committee 110: Electronic display devices.

The text of this standard is based on the following documents:

CDV	Report on voting
110/568/CDV	110/608A/RVC

Full information on the voting for the approval of this standard can be found in the report on voting indicated in the above table.

This publication has been drafted in accordance with the ISO/IEC Directives, Part 2.

A list of all parts in the IEC 61747 series, published under the general title *Liquid crystal display devices*, can be found on the IEC website.

The committee has decided that the contents of this publication will remain unchanged until the stability date indicated on the IEC web site under "<http://webstore.iec.ch>" in the data related to the specific publication. At this date, the publication will be

- reconfirmed,
- withdrawn,
- replaced by a revised edition, or
- amended.

A bilingual version of this publication may be issued at a later date.

## INTRODUCTION

Mobile electronic devices have become increasingly sophisticated and often include displays for the purposes of user interface and viewing. Such displays commonly incorporate a transparent cover glass which aids in protecting the display against the introduction of damage through routine device transport and use, as well as occasional or accidental misuse.

The purpose of this standard is to provide mechanical testing procedures for cover glasses utilized in such applications. Such glasses can be strengthened, for example via an ion-exchange process, which acts to increase mechanical strength through the introduction of a surface compressive layer.

## LIQUID CRYSTAL DISPLAY DEVICES –

### Part 40-2: Mechanical testing of display cover glass for mobile devices – Uni-axial flexural strength (4-point bend)

#### 1 Scope

This part of IEC 61747-40 is a mechanical performance testing procedure for cover glass used in electronic flat panel displays in mobile devices. This standard is focused on the measurement of as-received edge strength via uni-axial flexure generated by a four-point bend.

#### 2 Normative references

The following documents, in whole or in part, are normatively referenced in this document and are indispensable for its application. For dated references, only the edition cited applies. For undated references, the latest edition of the referenced document (including any amendments) applies.

IEC 61747-40-1, *Liquid crystal display devices – Part 40-1: Mechanical testing of display cover glass for mobile devices – Guidelines*

IEC 61649:2008, *Weibull analysis*

#### 3 Terms, definitions and abbreviations

##### 3.1 Terms and definitions

For the purposes of this document, the following terms and definitions apply.

##### 3.1.1

###### **specimen**

individual piece of glass to be tested to failure

##### 3.1.2

###### **sample**

group of specimens sharing a common pedigree (such as manufacturing process and period of production), for which failure statistics can be generated and reported

##### 3.1.3

###### **sample size**

number of specimens in a sample

##### 3.1.4

###### **nominal value**

value about which a tolerance range is specified

##### 3.1.5

###### **strength**

normalized load at which fracture occurs



Note 1 to entry: For glasses without a compressive surface layer, strength can be equated to the fracture stress. In cases where non-linearities prevent a suitable conversion from load to strength (or stress), load at fracture should instead be reported.

### 3.2 Abbreviations

PTFE polytetrafluoroethylene

## 4 General

This test measures edge strength by forcing a pair of parallel load bars (anvils) through a specimen that is supported by a pair of parallel support bars. The two pairs of bars shall be parallel and the applied force shall be perpendicular to the surface formed by the support bar pair. The loads at fracture are measured and converted to strength. Strength calculations are found in Clause 7.

The test is applied to a sample of several specimens. The sample statistics of the strength values are defined in Clause 7. The statistical values to be reported or specified are given in Clauses 8 and 9.

The specimens to be tested are typically 44 mm to 60 mm in width and 60 mm to 110 mm in length, with thickness ranging from 0,55 mm to 2,0 mm. When the specimen is placed on the support bars, a pair of opposite edges shall be aligned to be parallel with the support bars. Before the specimen is placed on the support bars, the surface that will contact the load bars is covered with a layer of polymeric adhesive tape to preserve the fracture surface, reduce the scattering of glass fragments upon fracture, and minimize contact damage. The support rods are also covered with PTFE tape and may be rollers, also to minimize contact damage and friction.

The general requirements of the apparatus are given in Clause 5. Apparatus dimensions can be affected by specimen dimensions. These relationships are outlined in 5.4. It should be noted that direct comparisons cannot be made between specimens tested under different apparatus/fixture dimensions or at different cross head traverse rates.

Testing procedures are given in Clause 6.

It is assumed that all measurements are performed by personnel skilled in the general art of mechanical property measurements. Furthermore, it should be assured that all equipment is suitably calibrated as is known to skilled personnel and that records of the calibration data and traceability are kept.

## 5 Apparatus

### 5.1 Testing environment and pre-conditioning

The standard testing environment is specified in IEC 61747-40-1. Specimens shall be stored in such an environment for at least four hours before testing.

### 5.2 Testing frame

The testing frame provides the aspects needed for the controlled vertical movement of some mechanical elements relative to a test fixture surface. It also includes a load cell to indicate the applied force of these mechanical elements against other mechanical elements that are attached to the test surface and detectors to indicate displacement from the start of motion. A controller is also required to coordinate the necessary motions. These may be driven by external commands or by load cell responses. Examples of motion directives include:

- Jog up or down.
- Slow manual up or down until the stop button is pushed.

- Return to a preset start of test.
- Traverse downward at a fixed rate until fracture is detected, then stop.
- Emergency stop.

In addition to providing motion control and measurement of load, the controller shall, at minimum, report the fracture load, allow the setting of the load rate and the display load as a function of time and/or deflection from the start of the test. Other features can include:

- The collection, organization, storage, and reporting information entered for the sample, its specimens, fracture load data, and statistical analysis results.
- Calculating individual specimen fracture strength using data input for the specimen and the fracture load.

The main structural elements of the testing frame shall be made of steel with dimensions large enough so compliance is essentially zero with respect to the maximum force that will be applied. This maximum force depends on the specimens being tested, but should generally be less than 10 kN. These elements include:

- the testing surface,
- vertical support columns,
- a cross head,
- motion tractors within the support columns,
- load cell assembly and attachment mechanisms.

The minimum and maximum rates of motion shall encompass the range of 0,001 mm/min and 1 000 mm/min.

The controller shall sample the load cell and displacement detectors at a minimum rate of 10 kHz.

The load cell shall be calibrated against a known weight, force gauge or load cell and be linear to within 1 % over the maximum applied force. The load cell shall be capable of being reset to zero after the attachment of mechanical elements to it before the apparatus setup is complete. It shall also include an attaching mechanism.

Figure 1 illustrates some of the elements of the testing frame.

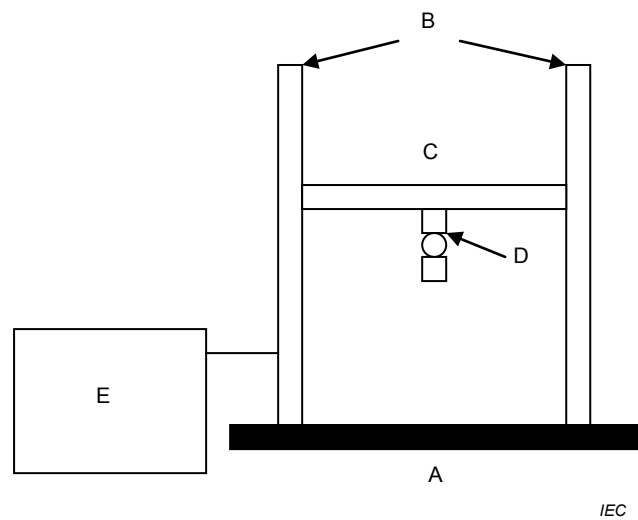
**Key**

- A Test surface
- B Support columns
- C Cross head (moves up and down)
- D Load cell assembly
- E Controller

**Figure 1 – Testing frame****5.3 Test fixture and setup**

Subclause 5.3 outlines the generic test fixture elements and setup procedure. Subclause 5.4 identifies the requirements of the dimensional characteristics, which can depend on specimen characteristics.

The primary test fixture elements are the support assembly and the load assembly. These are illustrated from Figure 2 to Figure 5. Other test fixture elements include:

- Clamps used to fasten the support assembly to the test frame testing surface.
- PTFE tape used to cover the support bars.
- Machined installation gage to align the support and load assemblies.
- Micrometer with flat anvil faces and resolution of 0,002 mm or better.

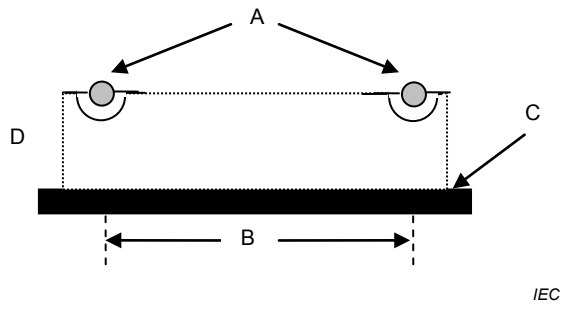

NOTE The key to the letters is provided in Figure 5.

**Figure 2 – Support assembly (side view)**

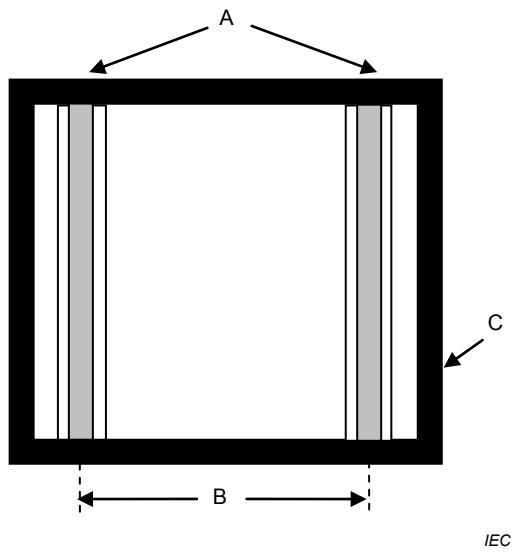

NOTE The key to the letters is provided in Figure 5.

**Figure 3 – Support assembly (top view)**

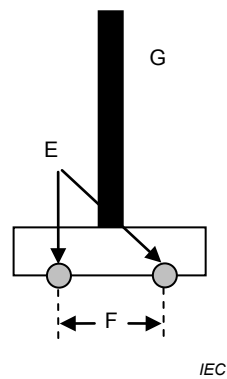

NOTE The key to the letters is provided in Figure 5.

**Figure 4 – Load assembly (side view)**

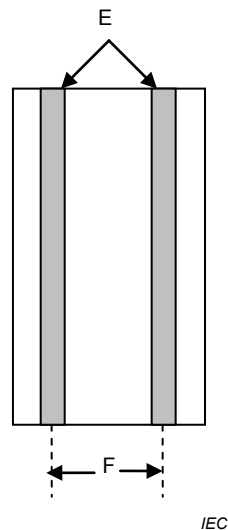

**Key**

- A Support bars with optional rollers
- B Support bar separation,  $d_S$
- C Support assembly attachment surface
- D Support assembly body
- E Load bars
- F Load bar separation,  $d_L$
- G Compression bar

**Figure 5 – Load assembly (bottom view)**

Setup steps include:

- a) Attach the load assembly to the test frame load cell assembly at the compression bar.
- b) Reset to zero on the load cell.
- c) Cover the support bars with PTFE tape.
- d) Roughly center the support assembly below the load assembly.
- e) Place the installation gage onto the support bars so the bottom grooves contain the bars.
- f) Slowly, lower the cross head and adjust the support assembly until the load bars are contained in the installation gage top grooves.

- g) Clamp the support assembly onto the test frame testing surface.
- h) Raise the cross head until the separation of the load and support bars is suitable for loading a specimen and set the start point.

The installation gage bar is a machined metal block with top and bottom grooves corresponding to the load bars and support bars respectively. It is used to assure parallel alignment of the two assemblies.

When assembled, the bars shall be parallel to 0,05 mm per 25 mm in length and concentric to within 0,25 mm. The parallelism requirement applies to:

- Support bar to support bar.
- Load bar to load bar.
- Support bars to load bars.

#### 5.4 Test fixture dimensions

The test fixture dimensions are driven by the specimen dimensions: length,  $l$ , width,  $w$ , and thickness,  $h$ . The radius of the load and support bars shall be greater than  $h/2$ .

The load and support bar lengths shall be large enough to accommodate the maximum specimen width.

The height of the support assembly body shall be sufficient to accommodate the maximum specimen deflection. This is influenced by several factors such as the following, and best determined experimentally:

- Young's modulus of the material under test.
- Fracture strength of the specimens under test.
- Specimen thickness and width.

The support bar separation,  $d_S$ , and load bar separation,  $d_L$ , are set in terms of the nominal specimen length,  $l_{nom}$ , as in equations (1) and (2).

$$d_S \leq \frac{4}{5} l_{nom} \quad (1)$$

$$d_L = \frac{1}{2} d_S \quad (2)$$

The support bar separation is critical to obtaining comparable testing results because it can affect the Weibull scaling parameter (see 7.2). Unless otherwise specified, the support bar separation is 36 mm  $\pm$  0,5 mm.

These dimensions are partly intended to prevent non-linearities in loading behavior due to large specimen deflection, slippage and/or run-out failure. The latter occurs when the deflection is large enough to draw the specimen ends past the support bars. In this case, the failure load does not correspond to specimen fracture, but rather to the load at which the specimen slipped out of the support bars. The associated load values shall be suspended (see 7.2). This failure mode can often be observed as an unusual discontinuity in the applied load graph. Figure 6 shows a normal load versus time graph, as well as a case of large deflection with associated slippage due to non-optimized span distances.

Support bar separation of 36 mm is needed to avoid excessive run-out failure on strengthened glasses. It provides 20 % excess glass on each side of the support bar rather than the base recommendation of 10 % excess glass.

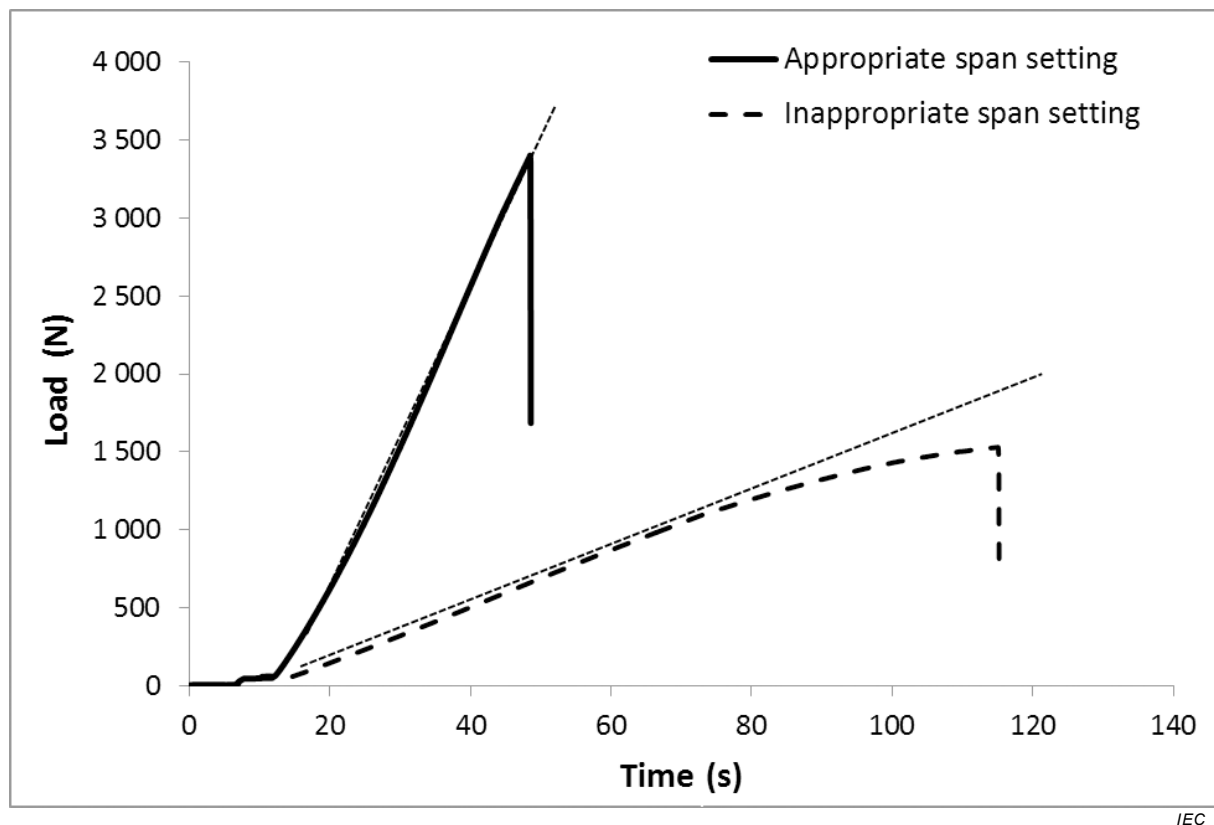

Appropriate span settings are required to avoid non-linearities due to large specimen deflections, slippage and/or run-out failure. The finely dashed lines are simply a guide to the eye.

**Figure 6 – Example load traces for appropriate and inappropriate span settings**

## 5.5 Loading rate

The loading rate during testing shall be constant. It is given in terms of the cross head traverse rate. Unless otherwise specified the rate is 5 mm/min. As with fixture dimensions, data generated from testing at different loading rates are not directly comparable.

## 6 Procedure

### 6.1 Safety

#### 6.1.1 Hazard – Broken glass

Wear safety glasses with side panels at all times. Wear gloves when handling broken glass.

#### 6.1.2 Crush hazard – Only one person may operate the testing frame

Operator injury may occur if more than one person operates the system. Before working in the hazard area between the upper and lower fixtures, ensure that other personnel cannot operate the computer system or other controls.

#### 6.1.3 Crush hazard – Take care when installing or removing a specimen

Installation or removal of a specimen involves working inside the hazard area between the fixtures.

- Keep clear of the fixture at all times.
- Never enter the hazard area between the fixtures while the cross head is moving.

#### **6.1.4 Hazard – Press the emergency stop button when an unsafe condition is observed**

If an unsafe condition is observed, press the emergency stop button. Correct the unsafe condition before resuming testing.

#### **6.1.5 Flying debris hazard – Ensure that specimens are installed correctly**

Always install the specimens in the center of the fixtures in line with the load path. Incorrect specimen installation creates stresses which can break the fixtures. The high energies involved can project broken parts some distance from the test area.

#### **6.1.6 Hazard – Protect control cables from damage or disconnection**

Protect all cables, particularly transducer cables, from damage. Damage to control and feedback cables can induce an open loop condition which may drive the cross head to the extremes of its motion.

### **6.2 Sample**

The sample size is 30, excluding any specimens rejected for pre-existing damage. Values associated with test run-out failure, surface breaks or edge breaks originating from outside of the load bar are included in the sample, but the values are treated as late suspensions (see 7.2). If there are more than 10 suspensions, the testing fails and a new sample shall be selected.

Upon receipt of a new sample, the following steps shall be taken:

- a) Determine and record the following information:
  - sample identification,
  - sample specimen nominal dimensions: length, width, thickness,
  - requesting person.
- b) Determine whether existing test fixtures are compatible. If not, change them (Clause 5).
- c) Record the fixture dimensions or identification number.
- d) Set and record the loading rate.
- e) Determine and record whether width is to be measured on each specimen. If specimen width varies less than 5 % of average, the average width may be used for each specimen.
- f) Set the start-of-test height for the testing frame.
- g) Zero the micrometer. This is done by gently closing the anvils with no specimen present, and pressing the reset button.

### **6.3 Individual specimen**

Complete the following steps on each specimen of the sample. The working surfaces should be clean and free of anything that can induce damage.

- a) Determine and record the specimen identification number.
- b) Inspect for any damage. If damaged, report this, but do not include in the testing.
- c) If required (see 6.2), measure and record the width.
- d) Measure and record the thickness to the nearest 0,001 mm. This measurement shall be done at a location on the specimen that is away from any edge and in a location that will not be stressed (the overhang area).
- e) Cut a section of polymeric adhesive tape that can cover the specimen and place it sticky side up on the working surface.
- f) Gently attach one edge of the specimen to one end of the tape.



- g) Gently lower the rest of the specimen onto the rest of the tape.
- h) Carefully trim the excess tape away from the specimen.
- i) Return the test frame to the start-of-test position and place the specimen onto the support bars with the polymeric adhesive tape side up.

NOTE The load bars will touch the polymeric adhesive tape side.

- j) Start the test sequence.
- k) Observe the load vs. time graph and other signs of testing progress for any abnormalities.
  - If abnormalities are observed (such as run-out failure), this may be cause to suspend the result.
- l) Record the failure load. Following this, calculate and record the failure stress (see 7.1).
- m) Inspect the fracture pattern to determine whether the break source originated from the edge between the load bars, the edge underneath the load bars, the edge outside of the load bars, or away from any edge. All but the first and second type listed, in which failure originates from an edge either underneath or between the load bars, shall be suspended. Figure 7 illustrates a normal edge fracture pattern illustrating the desired failure mode. Figure 8 illustrates an edge failure underneath the load bar, while Figure 9 illustrates a surface fracture.
- n) Remove the broken glass and thoroughly clean the area for the next test.

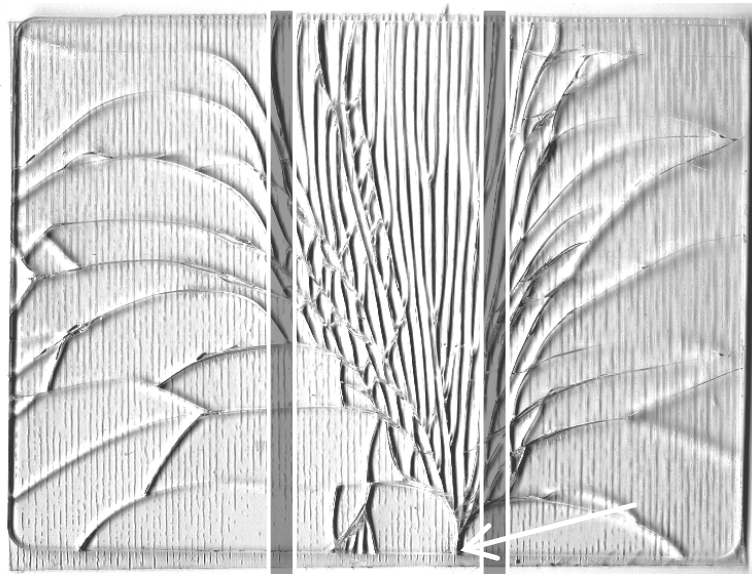

IEC

NOTE Such a fracture represents the desired failure mode, and thus the resulting data point is treated as non-suspended. The dark vertical bars indicate the approximate load bar positions, while the white arrow tip represents the failure origin location.

**Figure 7 – Edge fracture originating from between the load bars**

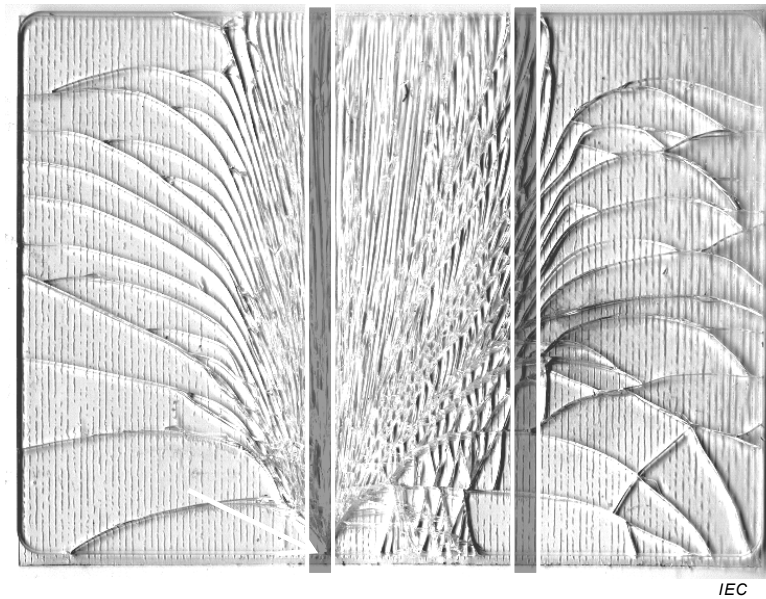

NOTE Such a fracture originates from underneath the load bar, and thus the resulting data point is treated as nonsuspended. The dark vertical bars indicate the approximate load bar positions, while the white arrow tip represents the failure origin location.

**Figure 8 – Edge fracture originating from underneath the load bar**

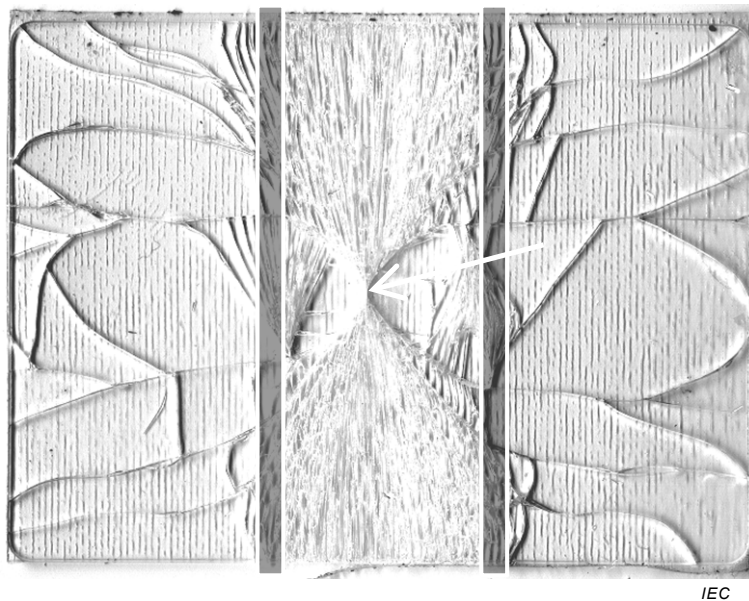

NOTE Such a fracture represents an undesired failure mode, and thus the resulting data point is suspended. The dark vertical bars indicate the approximate load bar positions, while the white arrow tip represents the failure origin location.

**Figure 9 – Surface fracture originating from between the load bars**

#### 6.4 Complete the report

The report shall include, at a minimum, the information found in 8.1. Individual customers may require additional information.

Depending on the capabilities of the testing frame controller, preparation of the report may require the statistical analysis items in 7.2 to be calculated, stored, and printed on another computer.

## 7 Calculations

### 7.1 Strength calculations

The following equations have been found applicable for the types of glass for which this standard is intended. Other types of glass may have non-linearities at elevated deflections.

Strength,  $\sigma$ , (MPa) is given as a function of fracture load (N) as equation (3).

$$\sigma = \frac{3L(d_S - d_L)}{2wh^2} \quad (3)$$

where:

$d_S$  = support bar separation

$d_L$  = load bar separation

$w$  = specimen width (mm)

$h$  = specimen thickness (mm)

$L$  = fracture load (N)

### 7.2 Statistical calculations

The Weibull analysis standard, IEC 61649, shall be used to calculate the following parameters:

- Weibull scale parameter,  $\eta$  (MPa).
- Weibull shape parameter,  $\beta$ .
- the 10<sup>th</sup> percentile failure stress,  $B_{10}$  (MPa).

The maximum likelihood estimate (MLE) method of calculation shall be used for the Weibull parameters. See 9.6 of IEC 61649:2008. The following equations are adapted from equations (17) and (18) of IEC 61649:2008 in order to accommodate suspensions as variable censoring. This is justified by considering a surface break. If the surface flaw had not been present, the largest edge flaw would have failed at a larger stress than the failure stress that is calculated for the surface flaw. In a sense, the testing of the edge flaw was terminated before failure.

Following the notation of IEC 61649, let  $t_i$  represent valid failure strength values, with  $i = 1$  to  $r$ , and let  $T_j$  represent the suspended values, with  $j = 1$  to  $s$ .

The shape parameter is the value of  $\beta$  that satisfies equation (4).

$$\frac{\sum_{i=1}^r t_i^\beta \ln t_i + \sum_{j=1}^s T_j^\beta \ln T_j}{\sum_{i=1}^r t_i^\beta + \sum_{j=1}^s T_j^\beta} - \frac{1}{\beta} - \frac{1}{r} \sum_{i=1}^r \ln t_i = 0 \quad (4)$$

Given this value for the shape parameter, the scale parameter is given as equation (5).

$$\eta = \left[ \frac{1}{r} \left( \sum_{i=1}^r t_i^\beta + \sum_{j=1}^s T_j^\beta \right) \right]^{1/\beta} \tag{5}$$

The point estimate of the 10<sup>th</sup> percentile,  $B_{10}$ , is calculated using 9.8 of IEC 61649:2008 and equation (20) of IEC 62649:2008, which is repeated here as equation (6). In Clause 9, this parameter is recommended to be specified for performance standards. It combines the scale and shape parameters to single, meaningful, metric.

$$B_{10} = \eta [-\ln(0,9)]^{1/\beta} \tag{6}$$

In addition to the calculation of statistical parameters, a Weibull plot is required (see 8.2). See 7.2.3 of IEC 61649:2008 for instructions on how to produce such a plot. An example Weibull plot is shown in Figure 10.

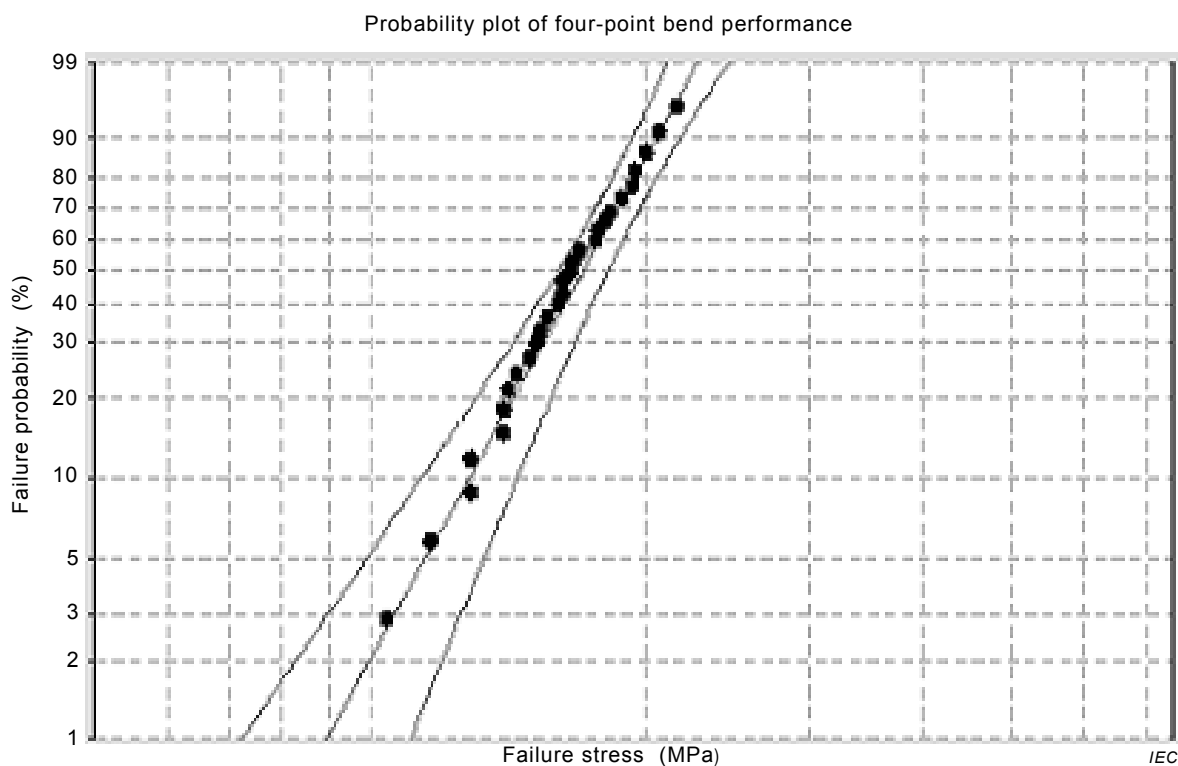

**Figure 10 – Example Weibull plot**

## 8 Reporting

### 8.1 Information to be reported for each test

Report the following for each test.

- Sample identification and nominal dimensions.
- Support bar separation,  $d_S$  (mm).
- Weibull scale parameter,  $\eta$  (MPa).
- Weibull shape parameter,  $\beta$ .
- Fracture strength 10<sup>th</sup> percentile,  $B_{10}$  (MPa).

## 8.2 Information to be made available upon request

The following information shall be available:

- Support and load bar radius.
- Cross head traverse rate (mm/min).
- All fracture loads:
  - Note suspensions and causes.
- Weibull plot.

## 9 Specifications

The following testing aspects require specification and control to obtain comparable results:

- Support bar separation,  $d_S$  (mm).
- Support and load bar radius (mm).
- Cross head traverse rate (mm/min).

The following parameter is recommended for specification in performance standards:

- The fracture strength 10<sup>th</sup> percentile,  $B_{10}$  (MPa).
-





INTERNATIONAL  
ELECTROTECHNICAL  
COMMISSION

3, rue de Varembé  
PO Box 131  
CH-1211 Geneva 20  
Switzerland

Tel: + 41 22 919 02 11  
Fax: + 41 22 919 03 00  
[info@iec.ch](mailto:info@iec.ch)  
[www.iec.ch](http://www.iec.ch)