

IS : 4997 - 1968
(Reaffirmed 1995)

Indian Standard

**CRITERIA FOR DESIGN OF HYDRAULIC
JUMP TYPE STILLING BASINS WITH
HORIZONTAL AND SLOPING APRON**

Sixth Reprint JANUARY 1998
(Incorporating Amendment No. 1)

UDC 627'831 : 624'04

© *Copyright* 1976

BUREAU OF INDIAN STANDARDS
MANAK BHAVAN, 9 BAHADUR SHAH ZAFAR MARG
NEW DELHI 110002

Gr 5

June 1969

Indian Standard

**CRITERIA FOR DESIGN OF HYDRAULIC
JUMP TYPE STILLING BASINS WITH
HORIZONTAL AND SLOPING APRON**

**Overflow Sections and Other Spillway Structures Sectional
Committee, BDC 54**

<i>Chairman</i>	<i>Representing</i>
DR K. C. THOMAS	Central Water & Power Commission, New Delhi
<i>Members</i>	
DIRECTOR (CENTRAL WATER & POWER RESEARCH STATION, DIRECTOR, DAMS III) (<i>Alternate</i>)	Central Water & Power Commission, New Delhi
DIRECTOR (H & S)	Central Water & Power Commission, New Delhi
SHRI N. K. DWIVEDI	Central Designs Directorate, Irrigation Department, Uttar Pradesh
DR GAJINDER SINGH	Land Reclamation, Irrigation & Power Research Institute, Punjab; and Public works Department, Government of Punjab
SHRI S. N. GUPTA	Central Board of Irrigation & Power, New Delhi
DR K. T. SUNDARARAJA IYENGAR	Indian Institute of Science, Bangalore
SHRI I. M. MAJUM	Public Works Department, Government of Mysore
SHRI M. V. A. SETTY (<i>Alternate</i>)	
SHRI V. B. MANERIKAR	Public Works Department, Government of Maharashtra
SHRI H. B. KULKARNI (<i>Alternate</i>)	
SHRI Y. K. MEHTA	Concrete Association of India, Bombay
SHRI J. P. MITAL	Institution of Engineers (India), Calcutta
SHRI J. NAGARAJ	National Projects Construction Corporation Ltd, New Delhi
SHRI D. M. SAVUR	Hindustan Construction Co Ltd, Bombay
DR HARI RAM SHARMA	Irrigation Department, Roorkee, Government of Uttar Pradesh
SHRI A. M. SINGAL	Beas Designs Organization, New Delhi
SHRI R. NAGARAJAN, Director (Civ Engg)	Director General, ISI (<i>Ex-officio Member</i>)

Secretary

SHRI VINOD KUMAR
Assistant Director (Civ Engg), ISI

**Panel for Criteria for Design of Hydraulic Jump Type Stilling Basins
with Horizontal and Sloping Apron, BDC 54:PI**

Member

DR HARI RAM SHARMA Irrigation Department, Roorkee, Government of
Uttar Pradesh

BUREAU OF INDIAN STANDARDS
MANAK BHAVAN, 9 BAHADUR SHAH ZAFAR MARG
NEW DELHI 110002

Indian Standard

CRITERIA FOR DESIGN OF HYDRAULIC JUMP TYPE STILLING BASINS WITH HORIZONTAL AND SLOPING APRON

0. FOREWORD

0.1 This Indian Standard was adopted by the Indian Standards Institution on 15 December 1968, after the draft finalized by the Overflow Sections and Other Spillway Structures Sectional Committee had been approved by the Civil Engineering Division Council.

0.2 The design of downstream protection works or energy dissipators below hydraulic structures occupies a vital place in the design and construction of dams weirs and barrages. The problem of designing energy dissipators is one essentially of reducing the high velocity flow to a velocity low enough to minimize erosion of natural river bed. This reduction in velocity may be accomplished by any or a combination of the following, depending upon the head, discharge intensity, tail-water conditions and the type of the bed rock or the bed material:

- a) Hydraulic jump type stilling basins:
 - 1) Horizontal apron type
 - 2) Sloping apron type
- b) Jet diffusion and free jet stilling basins:
 - 1) Jet diffusion basins
 - 2) Free jet stilling basins
 - 3) Hump stilling basins
 - 4) Impact stilling basins
- c) Bucket type dissipators.
 - 1) Solid and slotted roller buckets
 - 2) Trajectory buckets (ski-jump, flip, etc)
- d) Intersecting jets and other special type of stilling basins

0.3 The design criteria recommended in this standard is meant for stilling basins of rectangular cross-section with horizontal and sloping apron. The criteria given in this standard would hold provided that the jet entering the basin is reasonably uniform in regard to both velocity and depth. Though the criteria are applicable for all cases, yet for falls greater than 15 m, discharge intensities greater than $30 \text{ m}^3/\text{s}/\text{m}$ and possible asymmetry of flow, the specific design should be tested on model.

0.4 In the formulation of this standard due weightage has been given to international co-ordination among the standards and practices prevailing in different countries in addition to relating it to the practices followed in the field in this country. This has been met by deriving assistance from the following publications:

Annual research reports 1951 to 1961, published by Central Water Power Research Station, Poona.

Annual research reports 1957 to 1967, published by U.P. Irrigation Research Institute, Roorkee.

UNITED STATES. DEPARTMENT OF INTERIOR, BUREAU OF RECLAMATION. Engineering Monograph No. 25 Hydraulic design of stilling basins and bucket energy dissipators. Ed. 2. 1963.

1. SCOPE

1.1 This standard lays down the criteria for the design of hydraulic jump type stilling basins of rectangular cross section with horizontal and sloping apron utilizing various energy dissipators, for example, chute blocks, basin or floor blocks and end sill.

2. NOTATIONS

2.1 For the purpose of this standard, the following notations shall have the meaning indicated against each:

D_1 = depth of flow at the beginning of the jump, measured perpendicular to the floor

D_2 = depth conjugate (sequent) to D_1 for horizontal apron

D'_2 = depth conjugate (sequent) to D_1 for sloping apron (or partly sloping and partly horizontal)

D_b = depth of basin

D_c = critical water depth

F_1 = froude number of the flow at the beginning of the jump

g = acceleration due to gravity

h_b = height of basin blocks

h_c = height of chute blocks

H_L = head loss in hydraulic jump

h_s = height of end sill

IS : 4997 - 1968

- K = shape factor
- l = length of the inclined portion in basin IV
- L_b = length of the basin
- L_j = length of hydraulic jump
- q = discharge intensity
- s_b = spacing of basin blocks
- s_c = spacing of chute blocks
- s_d = spacing of dents in dentated sill
- V_1 = velocity of flow at the beginning of the jump
- V_2 = velocity of flow at the end of jump
- w_b = width of basin blocks
- w_c = width of chute blocks
- w_d = width of dents in dentated sill
- θ = angle of the sloping apron with the horizontal

3. TERMINOLOGY

3.0 For the purpose of this standard, the following definitions shall apply : see Fig. 1, 2A and 2B).

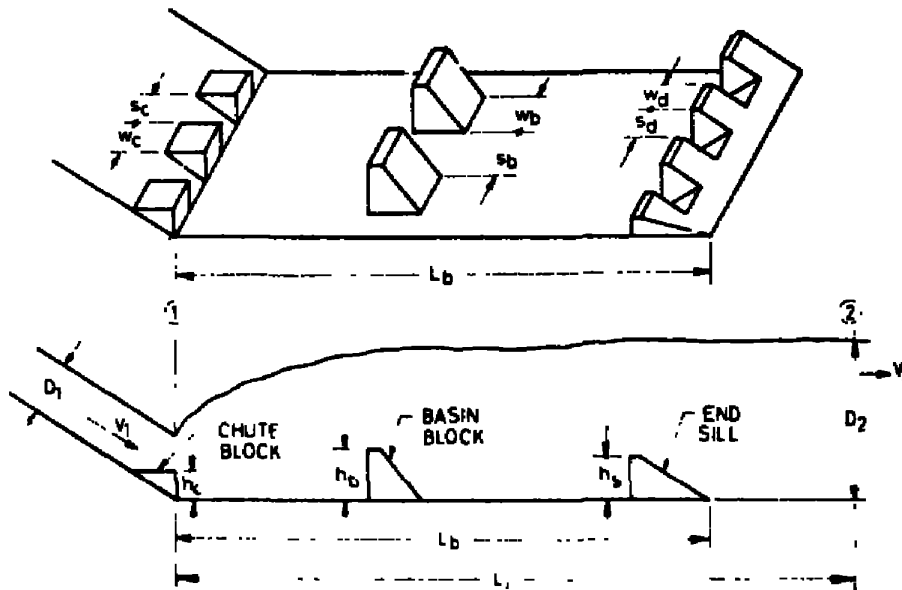

FIG. 1 DEFINITION SKETCH BASIN I AND II

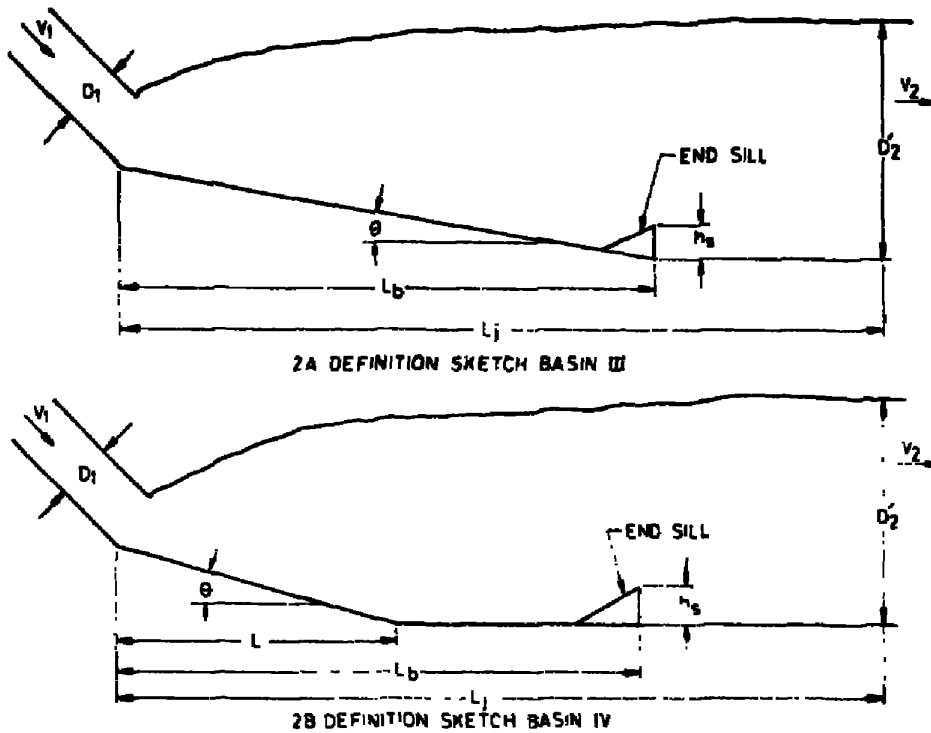

FIG. 2 DEFINITION SKETCHES OF BASIN III AND IV

3.1 Hydraulic Jump — Hydraulic jump in an open channel is an abrupt transition from the water depth $D_1 < D_c$ to $D_2 > D_c$.

3.2 Length of Hydraulic Jump — The distance from the beginning of the jump to a point downstream where either the high velocity jet begins to leave the floor or to a point on the surface immediately downstream of the roller, whichever is the longer. This may be determined from Fig. 3.

3.3 Conjugate Depths — Water depths at the beginning and the end of the hydraulic jump related by the formula:

$$\frac{D_2}{D_1} = \frac{1}{2} \left[\sqrt{1 + 8F_1^2} - 1 \right] \text{ for horizontal apron}$$

$$\frac{D_2}{D_1} = \frac{1}{2 \cos \theta} \left[\left(\frac{8F_1^2 \cos^3 \theta}{1 + 2K \tan \theta} - 1 \right)^{\frac{1}{2}} - 1 \right] \text{ for fully sloping apron}$$

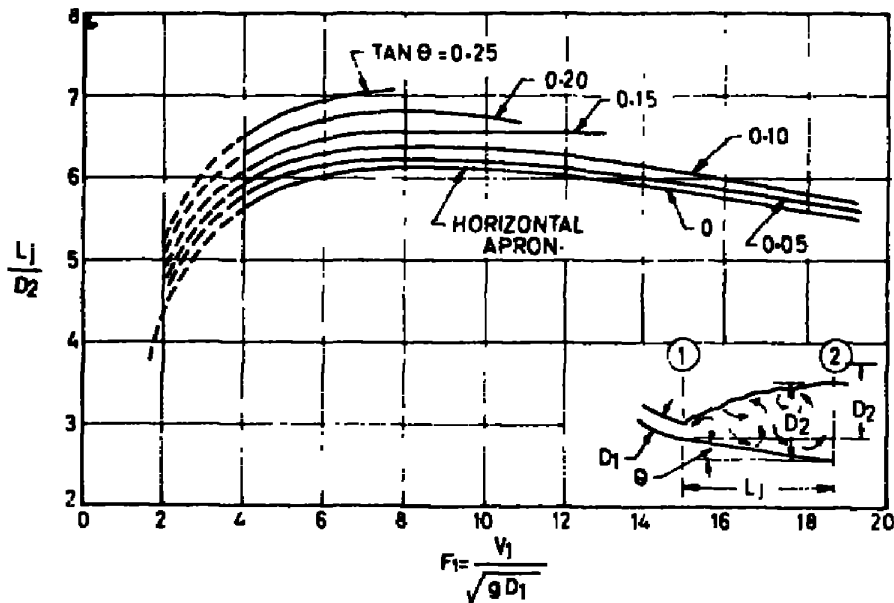

FIG. 3 LENGTH OF JUMP IN TERMS OF CONJUGATE DEPTH D_2 (BASIN III)

where approximate value of K may be determined from Fig. 4. However, D_2 may also be determined from Fig. 5 and 6.

3.4 Stilling Basin — A structure in which all or part of the energy dissipating action is confined. In a stilling basin the kinetic energy first causes turbulence and is ultimately lost as heat energy.

3.5 Hydraulic Jump Type Stilling Basin — A basin in which dissipation of energy is accomplished basically by hydraulic jump which may be stabilized using chute blocks, basin blocks, end sill, etc.

3.6 Length of Stilling Basin — Dimension of the basin in the direction of flow.

3.7 Width of Stilling Basin — Dimension of the basin perpendicular to the direction of main flow.

3.8 Chute Blocks — Triangular blocks installed at the upstream end of the stilling basin.

3.9 Basin Blocks/Baffle Blocks/Baffle Piers — Blocks installed on the basin floor between chute blocks and end sill.

3.10 End Sill — Solid or dentated wall constructed at the downstream end of the stilling basin.

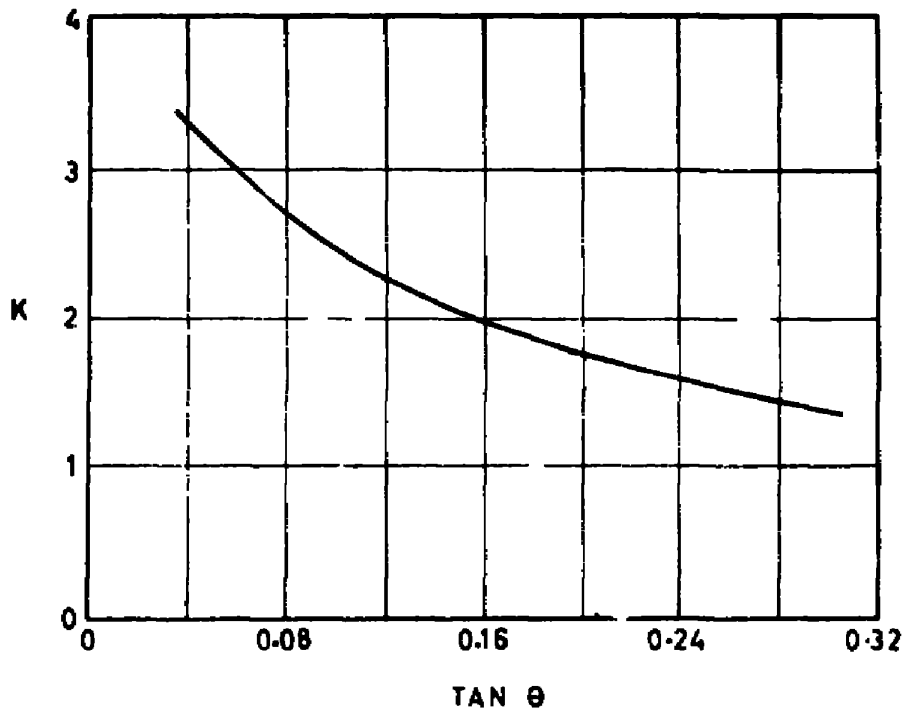

$$\frac{D'_s}{D_1} = \frac{1}{2 \cos \theta} \left[\left(\frac{8 F_1^2 \cos^2 \theta}{1 - 2 K \tan \theta} + 1 \right)^{\frac{1}{2}} - 1 \right]$$

NOTE — Above curve is based on assumption that K is independent of F_1 .

FIG. 4 CURVE FOR DETERMINATION OF SHAPE FACTOR

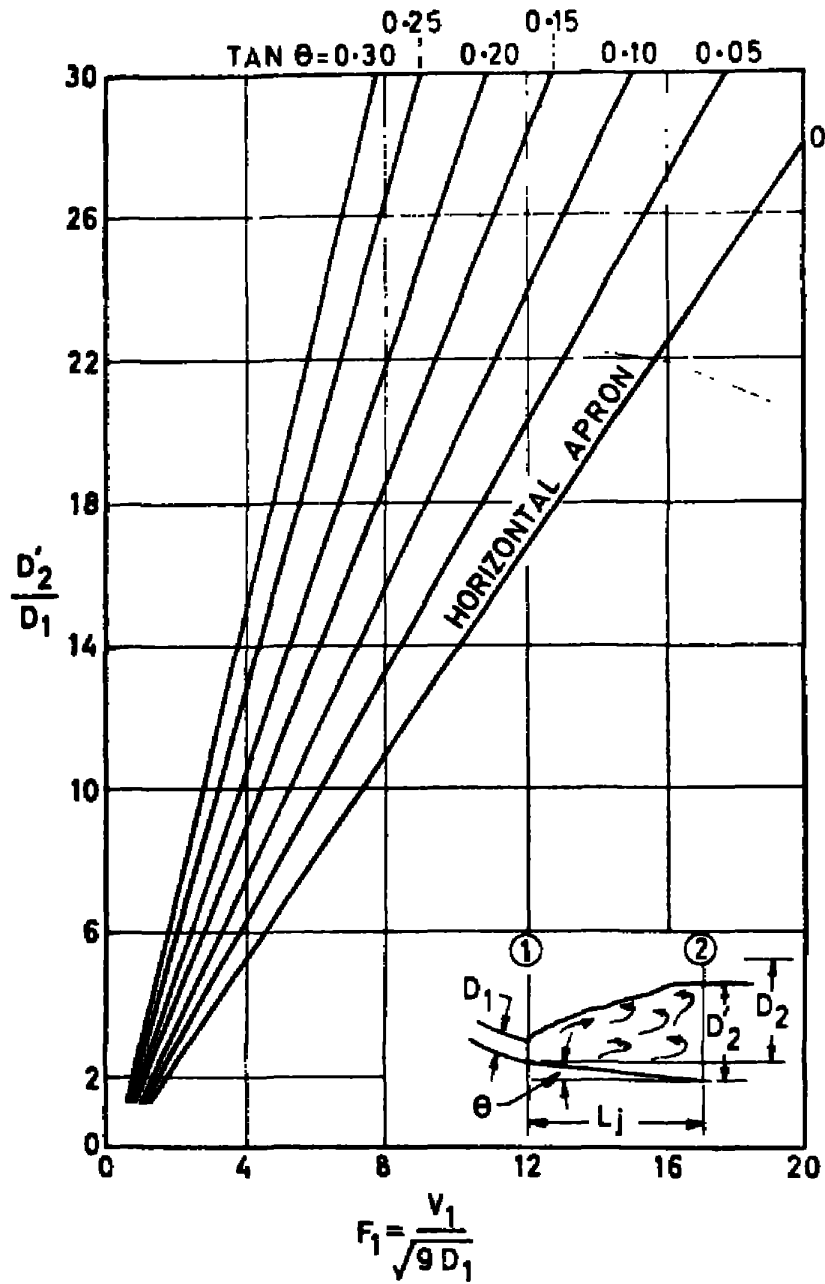

FIG. 5 RATIO OF CONJUGATE DEPTH D_2' TO D_1 (BASIN III)

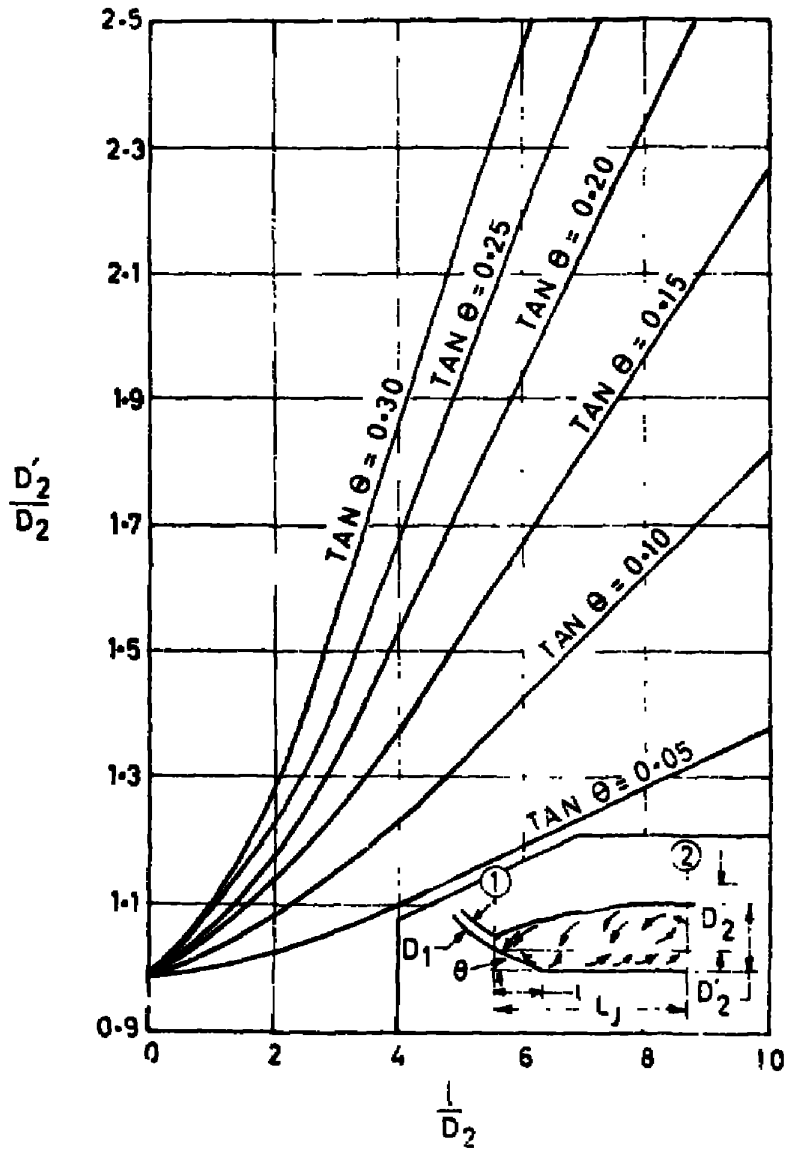

FIG. 6 TAIL WATER REQUIREMENT FOR SLOPING APRONS BASIN IV'

IS: 4997-1968

3.11 Froude Number—A dimensionless number characterizing the inertial and gravitational forces in an open channel flow and is defined as follows:

$$F = \frac{V}{\sqrt{gD}}$$

where

F = Froude number,

V = velocity of flow, and

D = depth of flow.

3.12 Shape Factor (K)—A dimensionless parameter which varies with the Froude number and the slope of the apron. This has been plotted against slope in Fig. 4 on the assumption that it is independent of Froude number.

4. HYDRAULIC JUMP TYPE STILLING BASIN WITH HORIZONTAL APRON

4.1 General—When the tail-water rating curve approximately follows the hydraulic jump curve or is only slightly above or below it, then hydraulic jump type stilling basin with horizontal apron provides the best solution for energy dissipation. In this case the requisite depth may be obtained on a proper apron near or at the ground level so that it is quite economical. For spillways on weak bed rock conditions and weirs and barrages on sand or loose gravel, hydraulic jump type stilling basins are recommended.

4.2 Classification—Hydraulic jump type stilling basin with horizontal apron may be classified into the following two categories:

- a) Stilling basins in which the Froude number of the incoming flow is less than 4.5. This case is generally encountered on weirs and barrages. This basin will be hereafter called as Basin I.

NOTE — Data on horizontal stilling basin for some of the existing and proposed weirs and barrages is given in Table 1.

- b) Stilling basins in which the Froude number of the incoming flow is greater than 4.5. This case is a general feature for dams. This basin will be hereafter called as Basin II.

NOTE — Data on horizontal stilling basins for some of the existing and proposed dam spillways is given in Table 2.

TABLE 1 DATA ON HORIZONTAL STILLING BASINS BELOW EXISTING AND PROPOSED WEIRS AND BARRAGES
[Clause 4.2(a)]

Sl. No.	NAME OF THE STRUCTURE	CUBIC METRE PER SECOND	(3)	(4)	D ₁ m	D ₂ m	F ₁	L _b m	L _b /D ₁	D _b m	D _b /D ₁	BASIN AFFURTENANCE		
												h_c/D_1	h_b/D_1	(12)
1.	Misan Barrage	4 500	21.1	21.1	1.55	6.91	3.50	25.39	3.68	3.41	0.79	0.97	—	0.26
2.	Bhimgoda Under Sluices	17 270	38.5	38.5	3.13	8.84	2.21	33.83	3.06	7.32	0.85	—	—	0.18
3.	Bhimgoda Weir	17 270	33.6	33.6	2.53	8.38	2.50	15.06	1.79	7.39	0.88	0.48	—	0.15
4.	Dhela Barrage	821	6.9	6.9	0.98	2.59	2.25	10.06	3.90	2.44	0.94	0.93	1.25	—
5.	Gandak Under Sluices	24 070	50.4	50.4	5.27	7.62	1.33	27.7	3.64	12.34	1.62	—	—	0.24
6.	Gandak River Sluices	24 070	50.4	50.4	5.27	7.62	1.33	29.3	3.84	12.80	1.63	—	—	0.24
7.	Gandak Barrage	24 070	48.5	48.5	4.18	6.77	1.46	28.27	4.18	10.82	1.60	—	—	0.27
8.	Malu Weir	31 170	45.9	45.9	2.78	11.13	3.17	14.94	1.44	13.53	1.22	—	—	0.23
9.	Narona Under Sluices	14 160	27.9	27.9	2.68	6.5	2.02	27.43	4.22	7.32	1.12	0.34	0.68	—
10.	Narona Barrage	14 160	18.2	18.2	1.84	3.12	2.23	18.32	3.38	6.10	1.19	0.48	0.97	0.18
11.	Pluka Under Sluices	1 048	13.0	13.0	1.22	4.79	3.38	12.80	2.67	4.00	0.83	1.06	1.25	—
12.	Pluka Barrage	1 048	10.9	10.9	0.96	4.40	3.66	11.89	2.70	3.70	0.84	1.11	1.27	—
13.	Sarda Under Sluices	16 980	46.5	46.5	3.44	9.6	2.33	30.48	3.17	9.14	0.95	—	—	0.19
14.	Sarda Barrages	16 980	39.0	39.0	3.11	8.87	2.27	24.38	2.75	5.79	0.65	—	—	0.10
15.	Yamuna Under Sluices	14 446	40.4	40.4	2.80	9.45	2.75	35.05	4.71	9.60	1.02	—	—	0.19
16.	Yamuna Barrage	14 446	31.4	31.4	2.35	8.47	2.80	30.48	3.60	8.38	0.69	—	—	0.18

TABLE 2 DATA ON HORIZONTAL STILLING BASINS BELOW EXISTING AND PROPOSED DAM SPILLWAYS

[Gate 4.2 b.]

Sl. No.	NAME OF THE STRUCTURE	Gate Centre METRE PER SECOND	Gate Width	D ₁	D ₂	F ₁	L _b	L ₃	D ₃	D _b	D _f	D ₂	BASIN APPROXIMATE		
													(3)	(4)	(5)
(1)	(2)			m	m	(7)	m	(9)	m	(10)	(11)	(12)	(13)	(14)	(15)
1.	Bachua Dam Spillway	2 124	23.2	1.62	7.47	3.61	27.43	3.67	11.31	1.51				0.24	
2.	Bhadai Dam Spillway	5 663	15.0	0.73	7.53	7.63	24.38	3.24	9.15	1.26				0.16	
3.	Bani Spillway	1 303	17.1	1.04	7.04	5.12	27.16	3.86	7.01	1.00				1.79	0.26
4.	Banas Dam Spillway	—	39.6	1.38	14.57	7.82	48.77	3.34	14.17	0.97					
5.	Gaudhi Sagar Dam Spillway	21 240	54.8	1.39	18.84	4.38	53.3	2.83	15.24	0.81					
6.	Hirakund Subsidiary Dam Spillway	1 133	40.4	1.48	14.23	7.11	10.06	0.70	6.10	0.43				1.23	0.21
7.	Jammu Dam Spillway	2 520	29.5	1.50	10.18	5.12	41.15	0.04	10.67	1.05		0.80	0.81	0.81	
8.	Kohra Dam Spillway	736	10.8	0.61	5.90	7.12	16.40	2.78	5.40	0.91		1.63		2.26	
9.	Kota Dam*	23 360	78.5	3.55	17.10	3.74	11.58	0.68	15.30	0.50				0.14	
10.	Matatila Dam Spillway Bay 1	16 940	40.4	1.67	13.56	5.93	37.50	2.76	4.48	0.33				0.18	
11.	do	"	"	"	"	"	34.59	2.53	6.31	0.46					
12.	do	"	"	"	"	"	31.48	2.31	6.66	0.71					
13.	do	"	"	"	"	"	30.48	2.24	11.19	0.82					
14.	Manglam Dam Spillway	287	11.8	0.61	6.5	7.91	24.38	3.75	5.18	0.80					
15.	Mooosi Khand Dam Spillway	5 097	34.8	1.52	12.01	5.91	32.00	2.16	12.71	1.06		0.80		0.20	
16.	Obra Dam Spillway Bay 1 to 3	13 590	64.7	2.67	16.64	4.74	47.10	2.82	21.64	1.30		1.50	1.88	0.24	
17.	do	"	"	"	"	"	48.46	2.90	20.12	1.21		1.50	1.71		
18.	do	"	"	"	"	"	51.21	3.07	17.07	1.02		1.00	1.37		
19.	Pali Dam Spillway	765	15.7	1.22	5.84	3.72	22.86	3.92	3.64	0.97				1.25	0.31
20.	Rameanga Dam Spillway	6 710	55.2	1.34	20.88	11.42	83.82	4.00	20.42	0.98		1.14		1.14	0.21

* These dams are not having hydraulic jump type stilling basins. The data is based on design proposals finalized on the model.

4.3 Design Criteria

4.3.1 Factors involved in the design of stilling basins include the determination of the elevation of the basin floor, the basin length and basin appurtenances, if any.

4.3.2 *Determining Elevation of the Basin Floor* — Knowing H_L and q ; D_c , D_1 and D_2 can be determined either from the following formulæ or from Fig. 7:

$$H_L = (D_2 - D_1)^3 / 4 D_1 D_2 \quad D_c = \left(\frac{q^2}{g} \right)^{1/3}$$

$$D_1 = -\frac{D_2}{2} + \sqrt{\frac{2q^4}{D_2 g} + \frac{D_2^2}{4}}$$

Having obtained D_1 and D_2 , the elevation of the basin floor may be calculated by either deducting the specific energy at section 1-1 from the total energy line at that section or that at section 2-2 from the downstream total energy line.

4.3.3 To calculate H_L from the known upstream and downstream total energy lines, the following procedure may be adopted:

- a) Where the basin is directly downstream from the crest or where, the chute is not longer than the hydraulic head, H_L may be assumed equal to the difference in the upstream and downstream total energy lines.
- b) Where the chute length exceeds the hydraulic head, D_1 should be first determined by taking H_L equal to the difference between the upstream and downstream total energy lines. Next calculate friction losses in the chute by Manning's formula and determine the more accurate value of H_L and consequently that of D_1 . The process may be repeated till the desired accuracy is achieved.

4.3.4 *Basin I* — Requirements for basin length, depth and appurtenances for Basin I are given in 4.3.4.1 and 4.3.4.2.

4.3.4.1 *Basin length and depth* — Length of the basin may be determined from the curve given in Fig. 8 A. The basin will be provided with an end sill preferably dentated one. In the boulder reach the sloping face of the end sill will be kept on the upstream side. Generally, the basin floor should not be raised above the level required from sequent depth consideration. If the raising of the floor becomes obligatory due to site conditions, the same should not exceed 15 percent of D_2 and the basin in that case should be further supplemented by chute blocks and basin blocks. The basin blocks should not be used if the velocity of flow at the location of basin blocks exceeds 15m/s and in that case the floor of the basin should be kept at a depth equal to D_2 below the tail-water level. The tail-water depth should not generally exceed 10 percent of D_2 .

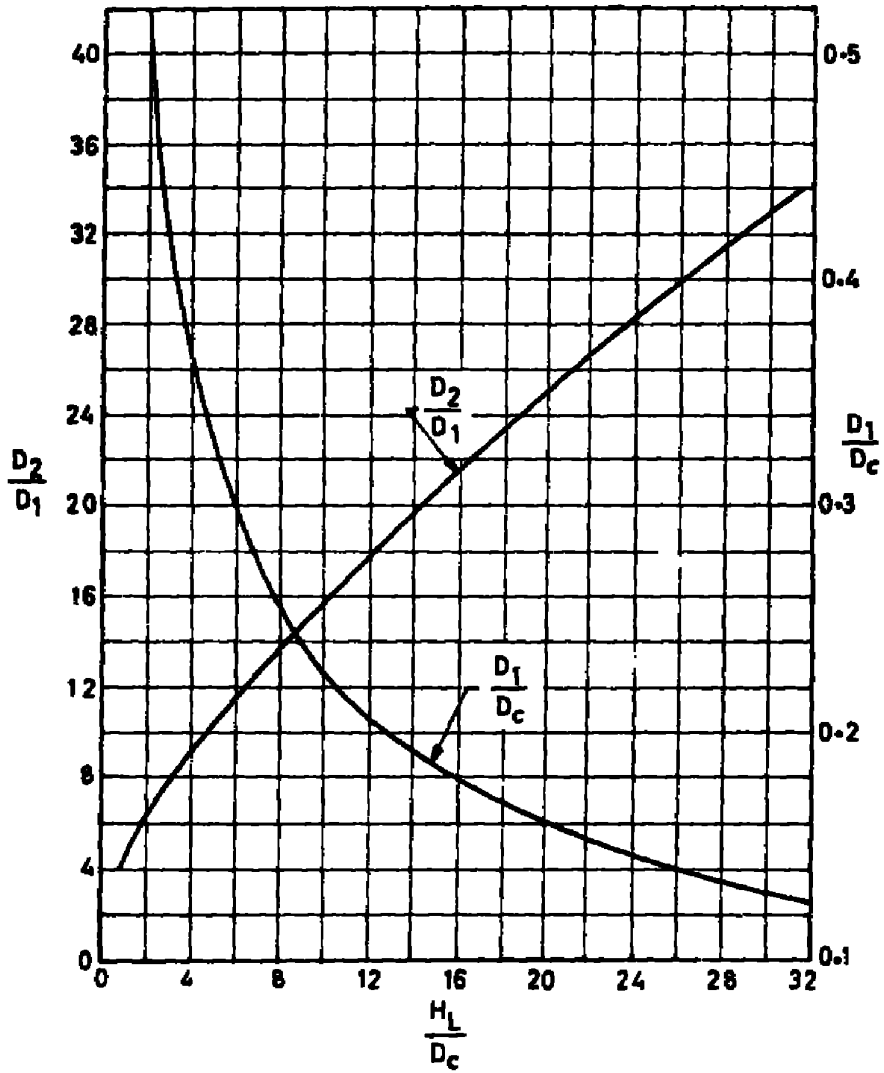
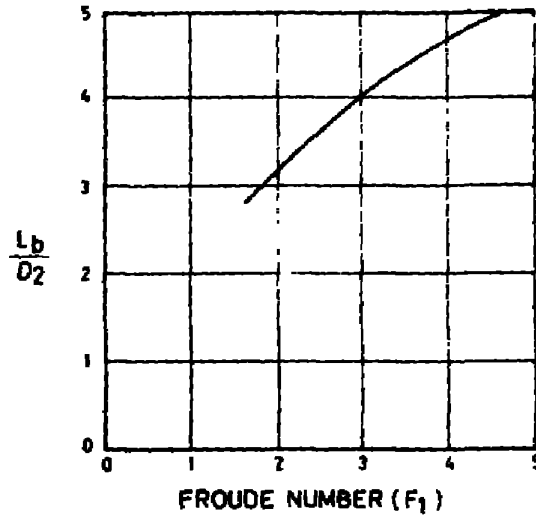

FIG. 7 CURVE FOR DETERMINATION OF SEQUENT DEPTH (HORIZONTAL APRON)

4.3.4.2 Basin appurtenances—Requirements for basin appurtenances, such as chute blocks, basin blocks, end sill are given below (see Fig. 8B):

- a) *Chute blocks*—The chute blocks should be kept at a height equal to $2D_1$ on the glasis slope. Their top length should also be equal to $2D_1$. The width of the chute blocks should be kept equal to D_1 and their spacing as $2.5 D_1$. A space equal to $D_1/2$ should be left along each wall.



8A RECOMMENDED LENGTH FOR BASIN I

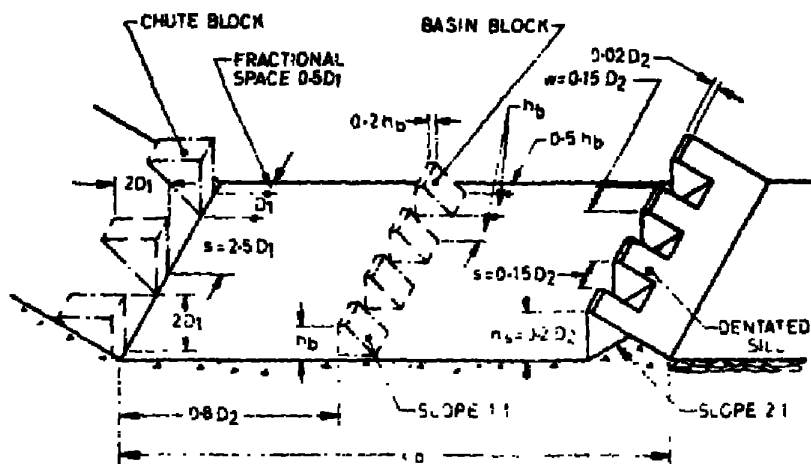

8B APPURTENANCES FOR BASIN I

FIG. 8 DIMENSION SKETCH FOR BASIN I

- b) *Basin blocks* — The height of basin blocks in terms of D_1 may be obtained from Fig. 9B. The width and spacing of the basin blocks should be equal to their height. The upstream face of all the basin blocks shall be vertical and in one plane. A half space is recommended adjacent to the walls. The upstream face of the basin blocks should be set at a distance of $0.8 D_2$ from the downstream face of the chute blocks.
- c) *End sill* — The height of the dentated end sill is recommended as $0.2 D_2$. The maximum width and spacing of dents shall be according to Fig. 8B. A dent is recommended adjacent to each side wall. In the case of narrow basin, it is advisable to reduce the width and spacing but in the same proportion. It is not necessary to stagger the end sill dents with reference to chute blocks.

4.3.5 Basin II — Requirements for basin length depth and appurtenances for Basin II are given in 4.3.5.1 and 4.3.5.2.

4.3.5.1 Basin length and depth — Length of the basin will be determined from the curve given in Fig. 9A. The basin should be provided with chute blocks and end sill. The maximum raising of the basin floor shall not exceed 15 percent of D_2 and the basin in that case will be further supplemented by basin blocks. However, when the flow velocity at the location of basin blocks exceeds 15 m/s, no basin blocks are recommended and in that case the floor of the basin should be kept at a depth equal to D_2 below the tail-water level. The tail-water depth should not generally exceed 10 percent of D_1 .

4.3.5.2 Basin appurtenances — Requirements for basin appurtenances, such as chute blocks, basin blocks and end sill are given below (see Fig. 9B):

- a) *Chute blocks* — The height, width and spacing of the chute blocks should be kept equal to D_1 . The width and spacing may be varied to eliminate fractional blocks. A space equal to $D_1/2$ is preferable along each wall.
- b) *Basin blocks* — The height of basin blocks in terms of D_1 can be obtained from Fig. 9B. The width and spacing should be kept three-fourth of the height. These should be placed at distance of $0.8 D_2$ downstream from the chute blocks.
- c) *End sill* — Same as clause 4.3.4.2.c.

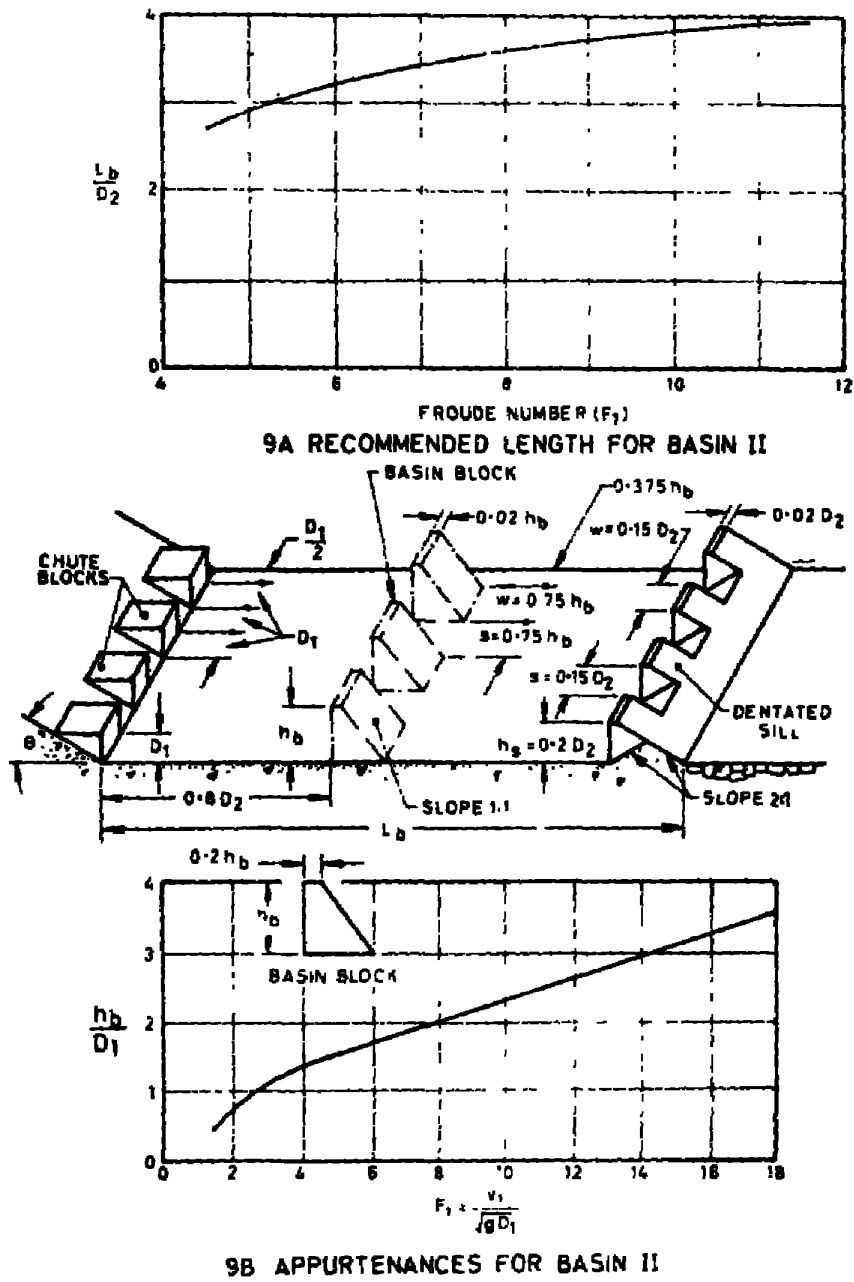

5. HYDRAULIC JUMP TYPE STILLING BASINS WITH SLOPING APRON

5.1 General—When the tail-water is too deep as compared to the sequent depth D_2 , the jet left at the natural ground level would continue to go as a strong current near the bed forming a drowned jump which is harmful to the river bed. In such a case, a hydraulic jump type stilling basin with sloping apron should be preferred as it would allow an efficient jump to be formed at suitable level on the sloping apron.

5.2 Classification—The hydraulic jump on a sloping apron may occur in four different forms depending on the tail-water conditions (Fig. 10). The action in cases *C* and *D* is same if it is assumed that horizontal floor begins at the end of the jump in case *D*. Case *B* is virtually case *A* operating with excessive tail-water depth. Case *A* has been dealt with previously in 4. In the subsequent paras criteria will be given for the design of stilling basins for cases *D* and *B* hereafter known as Basin III and Basin IV respectively.

5.2.1 Basin III is recommended for the case where tail-water curve is higher than the D_2 curve at all discharges.

5.2.2 Basin IV is suitable for the case where the tail-water depth at maximum discharge exceeds D_2 considerably but is equal to or slightly greater than D_2 at lower discharges.

5.3 Design Criteria

5.3.1 It is not possible to standardize design criteria for sloping aprons to the same extent as in the case of horizontal apron. In this case, greater individual judgment is required. The slope and overall shape of the apron are determined from economic consideration, the length being judged by the type and soundness of the river bed downstream. The following design criteria should serve only as a guide in proportioning the sloping apron designs.

5.3.2 Basin III—In the design of Basin III, the following procedure may be adopted:

- a) Assume a certain level at which the front of jump will form for the maximum tail-water depth and discharge.
- b) Determine D_1 from the known upstream total energy line by applying Bernoulli's theorem and calculate F_1 . Then find out conjugate depth D_2 from equation given in 3.3.
- c) Assume a certain slope and determine the conjugate depth D_2 and length of the jump for the above Froude number from Fig. 5 and Fig. 3 respectively. The length of the apron should be kept equal to 60 percent of the jump length.

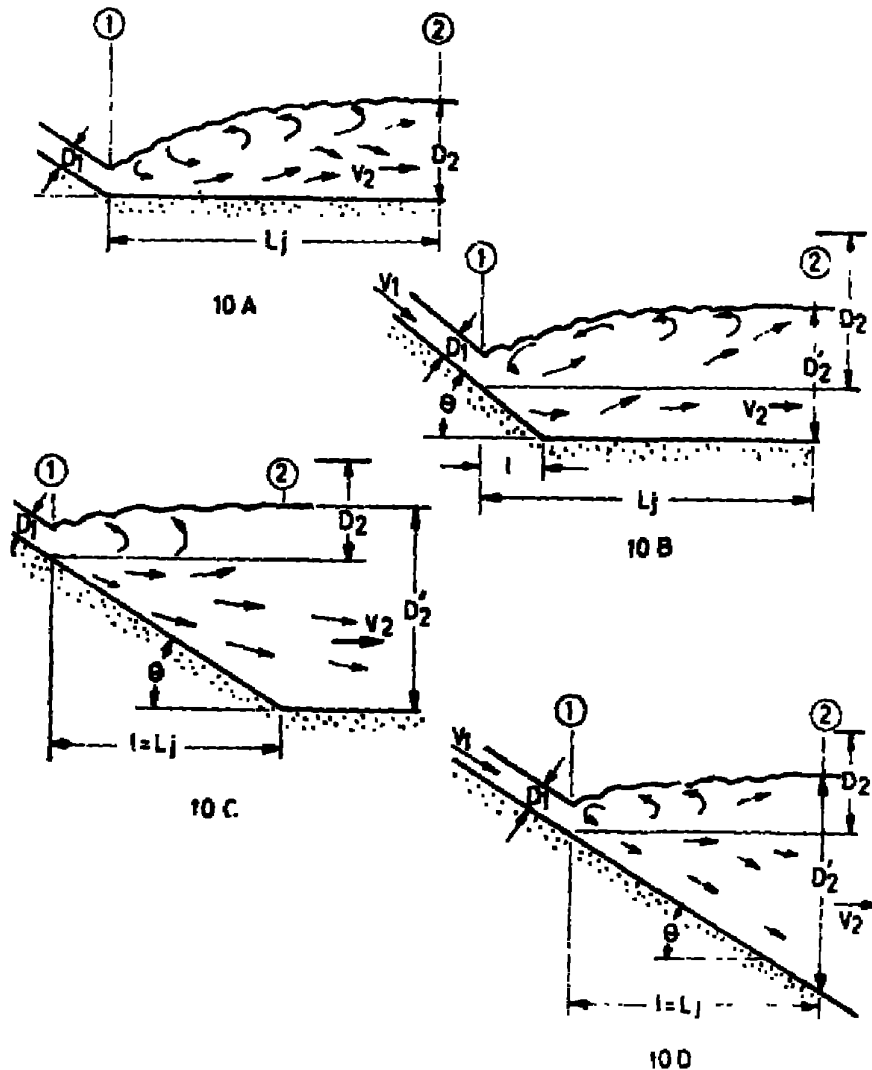

FIG. 10 DIFFERENT FORMS OF HYDRAULIC JUMP ON SLOPING APRON

- d) Test whether the available tail-water depth at the end of the apron matches the conjugate depth D'_2 . If not, change the slope or the level of the upstream end of the apron or both. Several trials may be required before the slope and the location of the apron are compatible with the hydraulic requirement.
- e) The apron designed for maximum discharge may then be tested at lower discharges, say $\frac{1}{2}$, $\frac{1}{3}$ and $\frac{1}{4}$. If the tail-water depth is sufficient

IS : 4997 - 1968

or in excess of the conjugate depth for the intermediate discharges, the design is acceptable. If not, a flatter slope at lower apron level should be tried or Basin IV may be adopted.

- f) The basin should be supplemented by a solid or dentated end sill of height equal to 0.05 to 0.2 D_2 with an upstream slope of 2 : 1 to 3 : 1.

5.3.3 Basin II' — In the design of Basin IV, the following procedure may be adopted:

- a) Determine the discharge at which the tail-water depth is most deficient.
- b) For the above discharge, determine the level and length of the apron on the basis of criteria given in 4.
- c) Assume a certain level at which the front of jump will form for the maximum tail-water depth and discharge.
- d) Determine D_1 from the known upstream total energy line by applying Bernoulli's theorem and calculate F_1 . Then find out conjugate depth D_2 from equation given in 3.3.
- e) Determine a suitable slope (by trial and error) so that the available tail-water depth matches the required conjugate depth D'_2 determined from Fig. 6.
- f) Determine the length of the jump for the above slope from Fig. 3. If the sum of the lengths of inclined portion and horizontal portion is equal to about 60 percent of the jump length, the design is acceptable. If not, fresh trials may be done by changing the level of the upstream end of the jump formation.
- g) The basin should be supplemented by a solid or dentated end sill of height 0.05 to 0.2 D_2 and upstream slope of 2 : 1 to 3 : 1.

BUREAU OF INDIAN STANDARDS**Headquarters:**

Manak Bhavan, 9 Bahadur Shah Zafar Marg, NEW DELHI 110002

Telephones: 323 0131, 323 3375, 323 9402

Fax : 91 11 3234062, 91 11 3239399, 91 11 3239382

Telegrams : Manaksanstha
(Common to all Offices)**Central Laboratory:**

Plot No. 20/9, Site IV, Sahibabad Industrial Area, Sahibabad 201010

Telephone

8-77 0032

Regional Offices:

Central : Manak Bhavan, 9 Bahadur Shah Zafar Marg, NEW DELHI 110002 323 76 17

*Eastern : 1/14 CIT Scheme VII M, V.I.P. Road, Maniktola, CALCUTTA 700054 337 86 62

Northern : SCO 335-336, Sector 34-A, CHANDIGARH 160022 60 38 43

Southern : C.I.T. Campus, IV Cross Road, CHENNAI 600113 235 23 15

† Western : Manakalaya, E9, Behind Marol Telephone Exchange, Andheri (East),
MUMBAI 400093 832 92 95**Branch Offices:**

*Pushpak, Nurmohamed Shaikh Marg, Khanpur, AHMEDABAD 380001 550 13 48

‡ Peenya Industrial Area, 1st Stage, Bangalore-Tumkur Road,
BANGALORE 560056 839 49 55

Gangotri Complex, 5th Floor, Bhadbhada Road, T.T. Nagar, BHOPAL 462003 55 40 21

Plot No. 62-63, Unit VI, Ganga Nagar, BHUBANESHWAR 751001 40 36 27

Kalaikathir Buildings, 670 Avinashi Road, COIMBATORE 641037 21 01 41

Plot No. 43, Sector 16 A, Mathura Road, FARIDABAD 121001 8-28 88 01

Savitri Complex, 116 G.T. Road, GHAZIABAD 201001 8-71 19 96

53/5 Ward No. 29, R.G. Barua Road, 5th By-lane, GUWAHATI 781003 54 11 37

5-8-56C, L.N. Gupta Marg, Nampally Station Road, HYDERABAD 500001 20 10 83

E-52, Chitaranjan Marg, C-Scheme, JAIPUR 302001 37 29 25

117/418 B, Sarvodaya Nagar, KANPUR 208005 21 68 76

Seth Bhawan, 2nd Floor, Behind Leela Cinema, Naval Kishore Road,
LUCKNOW 226001 23 89 23

NIT Building, Second Floor, Gokulpal Market, NAGPUR 440010 52 51 71

Patliputra Industrial Estate, PATNA 800013 26 23 05

Institution of Engineers (India) Building 1332 Shivaji Nagar, PUNE 411005 32 36 35

T.C. No. 14/1421, University P.O. Palayam, THIRUVANANTHAPURAM 695034 6 21 17

*Sales Office is at 5 Chowringhee Approach, P.O. Princep Street,
CALCUTTA 700072 27 10 85

† Sales Office is at Novelty Chambers, Grant Road, MUMBAI 400007 309 65 28

‡ Sales Office is at 'F' Block, Unity Building, Narashimaraja Square,
BANGALORE 560002 222 39 71