

**BUREAU OF INDIAN STANDARDS**

DRAFT FOR COMMENTS ONLY

*(Not to be reproduced without the permission of BIS or used as an Indian Standard)*

**भारतीय मानक मसौदा**

पानी पहुंचाने वाली सुरंगों के डिजाइन के लिए रीति संहिता  
भाग 4 चट्टानों में कंक्रीट अस्तर की संरचनात्मक डिजाइन  
(IS 4880 भाग 4 का पहला पुनरीक्षण)

**Draft Indian Standard**

**CODE OF PRACTICE FOR DESIGN OF TUNNELS CONVEYING WATER  
PART 4 STRUCTURAL DESIGN OF CONCRETE LINING IN ROCK**

*[First Revision of IS 4880(Part 4)]*

**Water Conductor Systems Sectional  
Committee, WRD 14**

**Last Date for Comments:  
20/12/2022**

Formatted: Justified

**FOREWORD**

*(Formal clauses of the foreword will be added later)*

Water conductor system occasionally takes the form of tunnels through high ground or mountains, in rugged terrain where the cost of surface pipe line or canal is excessive and elsewhere as convenience and economy dictates. This standard, which is being published in parts, is intended to help engineers in design of tunnels conveying water. This part lays down the criteria for structural design of concrete lining; for tunnels in rock, covering recommended methods of design. However, in view of the complex nature of the subject it is not possible to cover each and every possible situation in the standard and many times a deviation from the practices recommended in this standard may be considered necessary to meet the requirements of a project or site for which discretion of the designer would be required.

This standard is one of a series of Indian Standard on tunnels. The other parts of this standard are as follows:

- Part 1 General design
- Part 2 Geometric design
- Part 3 Hydraulic design
- Part 5 Structural design of concrete lining in soft strata and soils
- Part 6 Tunnel supports

Formatted: Justified

## Part 7 Structural design of steel lining

~~The first revision of the standard has been taken gaining the experiences from the field and inputs from different stake holders. This revision has been brought out to bring the standard in the latest style and format of the Indian Standards. In updation of this standard, assistance has been derived from the international practices. In addition, the following major changes have been incorporated. In updation of this standard assistance has been derived from the international practices. Major changes that have been brought out in this revision are~~

- a) Criteria for depth of the grout holes is modified in pressure grouting.
- b) Fig. 1 which shows typical section of concrete lined tunnel showing A-line and B-line has been updated.
- c) Structural steel has been omitted from definition of minimum excavation line (A-line).
- d) Criteria for backfill grouting has been updated.
- e) Criteria for design for external water pressure has been updated.

~~e)f) The formulas in Annex D have been reconciled with reference to the book Engineering Mechanics of Solids by Popov. Definition of  $b'$ , has been included taking reference from Civil Engineering Guidelines for Planning and Designing Hydroelectric Developments, Volume 2 Waterways ASCE.~~

For the purpose of deciding whether a particular requirement of this standard is complied with, the final value, observed or calculated, expressing the result of a test or analysis, shall be rounded off in accordance with IS 2: 2022 'Rules for rounding off numerical values (second revision)'. The number of significant places retained in the rounded off value shall be the same as that of the specified value in this standard.

Formatted: Font: 12 pt, Complex Script Font: 11 pt

Formatted: Font: 12 pt, Italic, Complex Script Font: 11 pt, Italic

Formatted: Font: 12 pt, Complex Script Font: 11 pt

Formatted: Font: 14 pt, Complex Script Font: 14 pt

Formatted: Font: 14 pt, Complex Script Font: 14 pt

Formatted: Justified

**Draft Indian Standard**

**CODE OF PRACTICE FOR DESIGN OF TUNNELS CONVEYING WATER  
PART 4 STRUCTURAL DESIGN OF CONCRETE LINING IN ROCK**

[First Revision of IS 4880(Part 4)]

**Water Conductor Systems Sectional  
Committee, WRD 14**

**Last Date for Comments:  
20/12/2022**

## 1 SCOPE

1.1 This standard (Part 4) covers criteria for structural design of plain and reinforced concrete lining for tunnels and circular shafts in rock mainly for river valley projects.

1.2 This standard however does not cover the design of steel and pre-stressed concrete linings, tunnels in swelling and/or squeezing type of rocks, soils or clays and cut and cover sections.

## 2 REFERENCES

The standards listed below contain provisions which, through reference in this text, constitute provisions of this standard. At the time of publication, the editions indicated were valid. All standards are subject to revision, and parties to agreements based on this standard are encouraged to investigate the possibility of applying the most recent editions of the standards indicated below:

<i>IS No.</i>	<i>Title</i>
<u>IS 456</u> : 2000	Code of practice for plain and reinforced concrete (fourth revision)
<u>IS 4880</u> (Part 5) : 1972 <i>Reviewed In : 2020</i>	Code of practice for design of tunnels conveying water: Part 5 Structural design of concrete lining in soft strata and soils
<u>IS 5878</u> (Part 7) : 1972 <i>Reviewed In : 2020</i>	Code of practice for construction of tunnels conveying water: Part 7 Grouting
<u>IS 13365</u> (Part 2) : 2019	Quantitative classification systems of rock mass — Guidelines Part 2 Rock mass quality for prediction of support (first revision)

Formatted: Left

Formatted: Left

Formatted: Left

Formatted: Left

NOTE — The provisions may, never the less, be used for design of any other type of tunnels, like railway or roadway tunnel, provided that all factors peculiar to such projects which may affect the design are taken into account.

### 3 TERMINOLOGY

For the purpose of this standard the following definitions shall apply.

**3.1 Minimum Excavation Line (A-Line)** - A line within which no unexcavated material of any kind and no supports other than permanent supports shall be permitted to remain. (see Fig. 1).

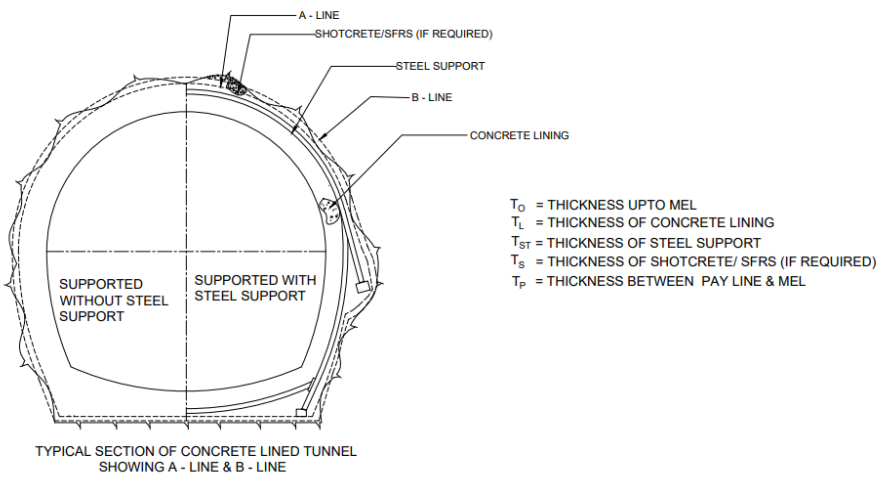

FIG. 1(a)

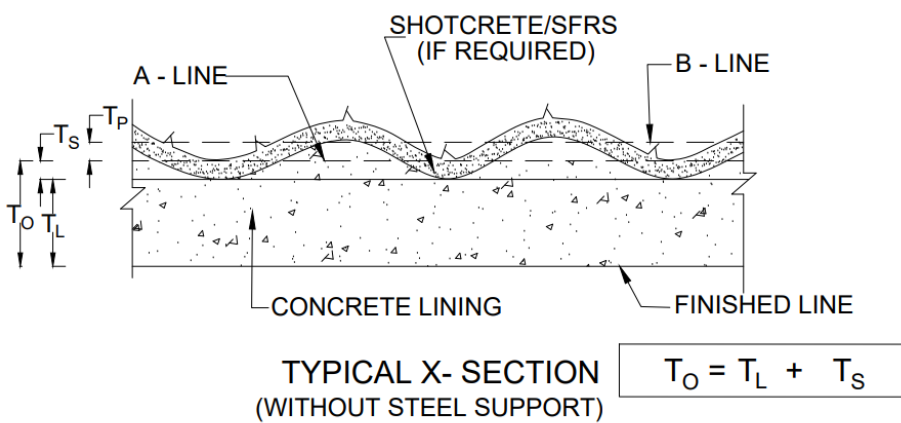
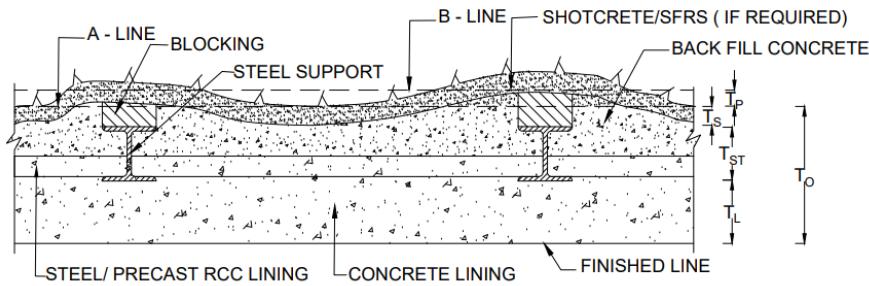

FIG. 1(b)



TYPICAL X-SECTION  
(WITH STEEL SUPPORT)

$$T_O = T_L + T_{ST} + T_S$$

FIG. 1(c)

FIG. 1: TYPICAL SECTION OF CONCRETE LINED TUNNEL SHOWING A - LINE AND B - LINE

**3.2 Pay Line (B-Line)** — An assumed line (beyond A-line) denoting mean line to which payment of excavation and concrete lining is made irrespective of the actual excavation falls inside or outside it. (see Fig. 1)

**3.3 Cover** — Cover on a tunnel in any direction is the distance from the tunnel soffit to the rock surface in that direction. However, where the thickness of the overburden is sizeable, its equivalent weight may also be reckoned provided that the rock cover is more than three times the diameter of the tunnel.

#### 4 MATERIAL

Use of plain and reinforced concrete shall conform to IS 456.

#### 5 General

**5.1** Structural design of tunnel lining requires a thorough study of the geology of rock mass, the effective cover, results of in-situ tests for modulus of elasticity, poisson's ratio, state of stress and other mechanical characteristics of the rock. It is preferable to make a critical study of these factors which may be done in pilot tunnels, test drifts, either during actual excavation or by other exploratory techniques. The assessment of rock load on the lining and portion of the internal pressure which shall be assumed to be transmitted to the rock mass, will have to be done by the designer on the basis of the results of these investigations.

**5.2** It is essential for the designer to have fairly accurate idea of the seepage, and the presence or absence of groundwater under pressure likely to be met with. Where heavy seepage of water is anticipated, the designer shall make provisions for grouting with cement and/or chemicals or extra drainage holes, and also consider the feasibility of providing steel lining, if necessary. It is recommended that such designs of alternate use of steel lining may be made along with the design of plain or reinforced lining so that

a design is readily available with the construction personnel when they meet unanticipated conditions.

**5.3** The portions of a tunnel which shall be reinforced and the amount of reinforcement required depend on the physical features of the tunnel, geological factors and internal water pressure. For a free-flow tunnel normally no reinforcement needs to be provided. However, reinforcement shall be provided where required to resist external loads due to unstable ground or grout or water pressures. Pressure tunnels with high hydrostatic loads shall have lining reinforced sufficiently to withstand bursting where inadequate cover or unstable supporting rock exists.

**5.3.1** The provision of reinforcement in the tunnel lining complicates the construction sequence besides requiring a thicker lining. The use of reinforcement should, therefore, be restricted, as much as possible consistent with the safety of lining. For free flow tunnels it is recommended that as far as possible, no reinforcement should be provided to resist external loads. Such loads should be resisted and taken care of by steel supports and/or precast concrete rings.

**5.3.2** A pressure tunnel should ordinarily be reinforced wherever the depth of cover is less than the internal pressure head. The final choice whether reinforcement should be provided or not, would be guided by the geological set up and economics.

**5.3.3** For design of junctions and transitions for tunnels, detailed structural analysis shall be made. Such transitions are difficult to construct in the restricted working space in tunnels, and the designer shall keep in view this aspect and propose structures which are easy for construction.

**5.3.4** An adequate amount of both longitudinal and circumferential reinforcement in addition to steel supports may be provided, if required, near the portals of both pressure and free-flow tunnels to resist loads resulting from loosened rock headings or from sloughing of the portal cuts.

**5.4** If the seepage of water through the lining is likely to involve heavy loss of water and the structural stability of the rock mass around the tunnel is likely to be affected adversely or might lead to such situation as to be damaging to the tunnel or adjoining structures, steel lining shall be provided. Where rock cover is less than that specified in **5.5** and **5.5.1** or where the cavitation of lining is expected due to the high velocity of water or erosion is expected the provision of a steel liner shall be considered.

**5.5** Where the rock is relatively impervious and the danger of blow out exists, the vertical cover shall be greater than the internal pressure head in the tunnel. In other cases, the weight of the rock over the tunnel shall be greater than the internal pressure.

NOTE — The conventional practice is to provide a vertical cover equal to the internal water pressure head ( $H$ ). Recent trend, however, is to provide lesser cover (as low as  $0.5 H$ ) depending upon the nature of the rock.

Formatted: Justified

**5.5.1** For tunnels located near mountain slopes, the lateral cover rather than the vertical cover may be the governing criteria many times. In such cases the effective vertical cover equivalent to the actual lateral cover shall be found out, by drawing a profile of the ground surface (perpendicular to the contour lines) and fitting the curve shown in Fig. 2 in such a way that it touches the ground surface. The vertical distance marked  $C_v$  shall be designated as the effective vertical cover and shall be greater than the internal pressure head in the tunnel. This method of estimating the effective cover shall not hold good where joints stratification, faults, etc. in the rock are adversely located to invalidate the assumption that horizontal cover is half as effective as the vertical cover on the basis of which the curve of Fig. 2 is drawn. In such cases special analysis shall be made for determining the stability of the rock mass around the tunnel.

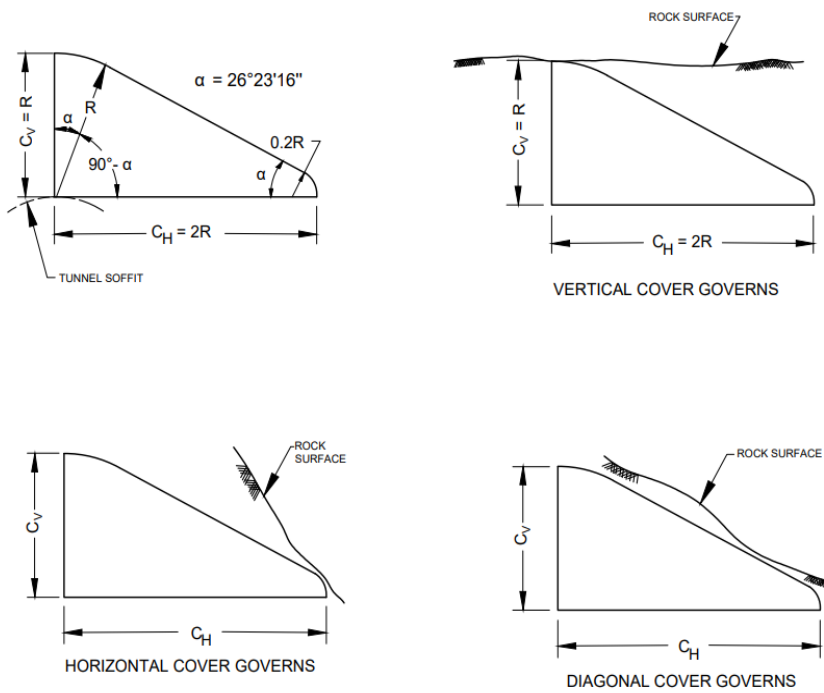

FIG. 2 ESTIMATION OF EFFECTIVE COVER

**6 LOADING CONDITIONS**

**6.1 General**

Design shall be based on the most adverse combination of probable load conditions, but shall include only those loads which have reasonable probability of simultaneous occurrence.

## 6.2 Load Conditions

The design loading applicable to tunnel linings shall be classified as 'Normal' and 'Extreme' design loading conditions. Design shall be made for 'Normal' loading conditions and shall be checked for safety under 'Extreme' loading conditions (see Annex A). The design loading shall be as follows:

- a) External Rock Load (see **8.4.2**)
- b) Self Load of Lining
- c) Design External Water Pressure (see **8.4.3**)
  - 1) Normal design loading conditions — The maximum loading obtained from either maximum steady or steady state condition with loading equal to normal maximum groundwater pressure and no internal pressure, or maximum difference in levels between hydraulic gradient in the tunnel, under steady state or static conditions and the maximum down surge under normal transient operation.
  - 2) Extreme design loading conditions — Loading equal to the maximum difference in levels between the hydraulic gradient in the tunnel under static conditions and the maximum down surge under extreme transient operations or the difference between the hydraulic gradient and the tunnel invert level in case of tunnel empty condition.
- d) Design of internal water pressure
  - 1) Normal design loading conditions — Maximum static conditions corresponding to maximum water level in the head pond, or loading equal to the difference in levels between the maximum upsurge occurring under normal transient operation and the tunnel invert.
  - 2) Extreme design loading conditions — Loading equal to the difference between the highest level of hydraulic gradient in the tunnel under emergency transient operation and the invert of the tunnel.
- e) Grout pressures (see **8.4.4**)
- f) Other Loads — Pressure transmitted from buildings and structures on external surface lying within the area of subsidence and non-permanent loads such as weight of vehicles moving in the tunnel or on the surface above it, where applicable.

**6.3** The loading conditions vary from construction stage to operation stage and from operation stage to maintenance stage. The design shall be checked for all probable combination of loading conditions likely to occur during all these stages.



Formatted: Justified

## 7 STRESSES

7.1 For design of concrete lining the thickness of concrete up to A-line shall be considered. The stress of concrete and reinforcement shall be in accordance with IS 456, for design of lining for conditions of normal load.

7.1.1 For extreme conditions of loading, the permissible stresses in accordance with 7.1 shall be increased by  $33\frac{1}{3}$  percent.

Formatted: Font color: Auto

## 8 DESIGN

8.1 The design of concrete lining for external loads may be done by considering it as an independent structural member (see 8.4). The design of concrete lining for internal water pressure may be done by considering the lining as a part of composite thick cylinder consisting of peripheral concrete and surrounding rock mass subjected to specific boundary conditions (see 8.5).

NOTE — To ensure validity of the assumption that lining is a part of composite thick cylinder in the latter case, adequate measures shall be taken such as pressure grouting of the rock mass surrounding the tunnel.

### 8.2 Thickness of Lining

The thickness of the lining shall be designed such that the stresses in it are within permissible limits when the most adverse load conditions occur. The minimum thickness of the lining will, however, be governed by requirements of construction. It is recommended that the minimum thickness of unreinforced concrete lining to be 15 cm for manual placement. Where mechanical placement is contemplated the thickness of the lining shall be so designed that the slick line can be easily introduced on the top of the shutter without being obstructed by steel supports. For a 15 mm slick line a clear space of 18 cm is recommended. For reinforced concrete lining, a minimum thickness of 30 cm is recommended, the reinforcement, however, being arranged in the crown to allow for proper placement of slick line.

8.2.1 For preliminary design of lining for tunnels in reasonably stable rock, a thickness of lining may be assumed to be 6 cm per meter of finished diameter of tunnel.

NOTE — Minimum thickness of lining, as necessary from structural considerations, shall be provided since thin linings are more flexible and shed off loads to the abutments.

8.3 Where structural steel supports are used, they shall be considered as reinforcement only if it is possible to make them effective as reinforcement by use of high tensile bolts at the joints or by welding the joints. A minimum cover of 15 cm shall be provided over the inner flange of steel supports and a minimum cover of 8 cm over the reinforcement bars.

NOTE — Welding of joints in soft strata tunnels may not be possible, and it may become necessary to embed the steel supports partly or fully in primary concrete immediately after erection. Welded joints shall, therefore, be avoided.

## 8.4 Design for External Loads

The lining may be considered as an independent structural element assuming that it deflects under the active external loads and its deflection is restricted by the passive resistance developed in the surrounding rock mass. At any point on the periphery of the lining this may be stated by the following equation:

$$\Delta p = \Delta r + \Delta e + \Delta w - \Delta y$$

Where,

- $\Delta p$  = deflection due to passive resistance,
- $\Delta r$  = deflection due to rock load,
- $\Delta e$  = deflection due to self-weight of lining and the water contained in it,
- $\Delta w$  = deflection due to the external water pressure; if any, and
- $\Delta y$  = yield of surrounding rock mass due to abutting of the lining against it.

**8.4.1** The following loads and reactions are involved in the design of lining:

- a) Rock load, (see **8.4.2**)
- b) External pressure of water; if any, (see **8.4.3**)
- c) Grout pressure; if any, (see **8.4.4**)
- d) Self-weight of lining,
- e) Weight of water contained in the tunnel,
- f) Reaction due to active vertical loads (see **8.4.5**), and
- g) Lateral passive pressure due to the deformation of lining. (see **8.4.6**)

NOTE — As compared to the other loads, the self-weight and the weight of water contained in the tunnel are small. These loads are not discussed in detail. However, the formulae for calculating bending moment, thrust, radial shear and horizontal and vertical deflections caused by self-load and the weight of water contained in the conduit are given in Annex C.

### 8.4.2 Rock load

Rock load acting on the tunnel varies depending upon the type and mechanical characteristics of rock mass, pre-existing stresses in the rock mass and the width of the excavation. The rock load is also affected by groundwater conditions which may lubricate the joints in rock and cause greater load than when the material is dry.

The existing stresses and their distribution after tunnelling has a great effect on the development of load on tunnel lining. The redistribution may take considerable time to reach an equilibrium condition. Wherever it is felt that rock loads are likely to develop excessively, it is advisable to prevent the movement of rock by immediately supporting it by rockbolts, shotcreting and/or steel supports. Where weak rocks are supported by steel rib supports, much of the rock load would be taken by the supports and the lining would take the load developed after its placement. There may also be redistribution of stresses in supports due to deformation of the lining. A reasonable approach is to

determine the diametral changes in the supported section with respect to time before concreting to estimate the extent of deformation that has already taken place. This investigation may be conveniently done in an experimental section of the tunnel or pilot tunnel with proper instrumentation.

In major tunnels, it is recommended that as excavation proceeds, load cell measurements and diametrical change measurements are carried out to estimate the rock loads. In rocks where the loads and deformations do not attain stable values, it is recommended that pressure measurements shall be made using flat jack or pressure cells.

**8.4.2.1** The magnitude of rock load to be considered in design of lining will depend on the time of placement of lining. Generally, it is not feasible to place the concrete lining just after tunnel excavation. In longer tunnels, lining is placed after at least one face length is fully excavated or after complete excavation of tunnel. By that time rock mass, installed with rock support to carry ultimate load, would have reached equilibrium state. In such conditions, rock load may need not to be considered in the design of concrete lining. However, lining shall be designed for estimated rock loads where the rock mass has not attained equilibrium.

**8.4.2.2** The rock loads may be estimated in accordance with IS 13365 (Part 2). In the absence of any data and investigations, rock loads may be assumed to be acting uniformly over the tunnel crown as shown in Fig. 3 in accordance with Annex B. However, Annex B may be taken as an aid to judgment by the designer.

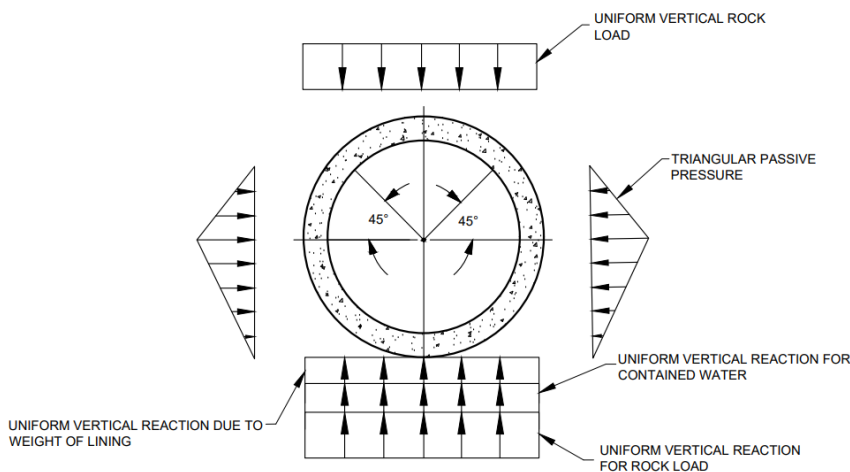

FIG. 3 EXTERNAL LOADS ON LINING

#### 8.4.3 External Water Pressure

Lining shall be designed for external water pressure, if any. However, in areas where drainage holes are provided, the lining should be designed to withstand a proportion of the total external water pressure because the drains cannot reduce the pressures to zero, and there is always a chance that some drains may get clogged. With proper drainage, the design water pressure may be taken as the lesser of the following:

- a) 25 percent of the full pressure, and;
- b) Pressure equivalent to a column of water three tunnel diameters high ( $3D$ ), where  $D$  is diameter of the finished tunnel.

#### **8.4.4 Grout Pressures**

The lining shall be checked for stresses developed in it at the pressure on which grouting is done and it shall be ensured that the stresses are within the limits depending on the strength attained by concrete by then (see **10.1** and **10.2**). To account for non-uniform grouting load, or loads due to void behind lining, the lining shall also be checked for maximum permitted grout pressure over area equal to one quarter the tunnel diameter, subject to maximum 1.5 m.

#### **8.4.5 Vertical Reactions**

Reactions due to the vertical loads may be assumed, reasonably, to be vertical and uniformly distributed on the invert of the lining as shown in Fig.3

NOTE — These reactions may not be uniform depending upon the foundation conditions. Nevertheless, with the uncertainties involved in the design of tunnels, the assumption may not give accurate results. On the other hand, uniform reactions would give more critical condition.

#### **8.4.6 Lateral Passive Pressure**

The lateral passive pressure may be estimated either by considering the lining as a ring restrained by elastic medium with a suitable modulus of deformation or by restricting the maximum deflection of the lining at the horizontal diameter to an assumed value (depending upon the yield of the surrounding rock mass) by the lateral passive pressure. The latter method is discussed in details in **8.4.6.1** for design of circular linings. For design of non-circular linings, the former method shall only be used.

**8.4.6.1** For analyzing a circular lining, the designer will have to assume the maximum deflection to be permitted along the horizontal central axis of the tunnel. This value of horizontal deflection will consist of the yield of the rock mass surrounding the tunnel (see Note 2). It may be assumed that any further deflection of the lining is restricted to this value by the lateral passive resistance of the surrounding rock mass in a pattern given in Fig.3. The design shall be such that the maximum value of the passive resistance is within the maximum permissible values.

NOTE 1 — For circular lining the deflection is outward in a zone extending approximately from 45° above the horizontal diameter to the invert as the invert move up. The maximum value is near

horizontal diameter. On the above consideration and neglecting the effect of vertical translations of the lining, the lateral rock restraint may be assumed to have approximately a triangular distribution as shown in Fig. 3. The vertical translation of the lining would cause a shifting of the point of maximum intensity slightly below the horizontal diameter and restriction of the upper limit to an angle slightly less than 45°, but the effect of vertical translation would be small and can be neglected. The passive pressure would, in fact, be also radial to the surface but in view of the fact that the deflections would be mostly in horizontal direction and vertical deflections would be small, it may be assumed to act in horizontal direction.

NOTE 2 —The rock mass surrounding the tunnel yields due to the bearing pressure of lining against it. This yield may be due to closing up of joints and fractures in the rock mass and also due to its elastic or plastic deformation. The value of yield taken for design shall be based on the experiments carried out in the test sections (see 5.1)

At Bhakra Dam, rock deflection tests indicated yield of either face in poor shattered rock as 1.25 mm under a stress of 54 kg/cm<sup>2</sup>. However, a total deflection of 3.8 mm was assumed in the design of lining though actual bearing pressure on the rock was anticipated to be much less. Experiments on Garrison Dam tunnels, in clay shale of internal diameter 8.8 m and lining thickness of 0.9 m indicated deflection of either face of lining at horizontal diameter to range between 3 to 4 mm. In design of Ramganga Dam tunnels outer deflection of either face of lining at horizontal diameter was assumed to be 3.8 mm.

**8.4.6.2** Formulae for determining the values of horizontal deflection, vertical deflection, bending moments, normal thrust and radial shear for the various circumferential points on a circular lining are given in Annex C considering the invert as the reference point for various loads excepting the internal pressure. In derivation of these values the pattern of vertical reaction and passive pressure has been assumed in accordance with 8.4.5 and 8.4.6 as shown in Fig. 3.

**8.4.7** For non-circular lining numerical methods are recommended to determine the stress distributions.

## 8.5 Design for Internal Water Pressure

Lining shall be considered as a part of composite thick cylinder consisting of peripheral concrete and surrounding rock mass subjected to specified boundary conditions.

NOTE — This method suffers from uncertainties of external loads, material properties and indeterminate tectonic forces. In this method the rock surrounding the tunnels is assumed to have reasonably uniform characteristics and strength and that effective pressure grouting has been done to validate the assumption that concrete lining and surrounding rock behave as a composite cylinder. The grout fills the crack in the rock & thus reduces its ability to deform inelastically and increased the modulus of deformation. The grout pressures are high enough to cause sufficient pre-stress in the lining with the result that the effect of temperature and drying shrinkage and inelastic deformation might be completely counteracted.

**8.5.1** For analyzing a circular lining the method given in Annex D may be adopted. The design shall be such that at no point in the lining and the surrounding rock the stresses exceed the permissible limits.

If the rock is very good, cracking of lining may be permitted to some extent provided it is not otherwise harmful. In that case, tangential stresses in concrete lining will be absent and correspondingly, tangential stress in rock will increase.

If the rock is not good, tensile stress in concrete may exceed the allowable limit and in such a case, reinforcement may be provided. Reinforcement however, is not capable of reducing the tensile stresses to a considerable extent. By suitable arrangement, it will help to distribute the cracks on the whole periphery in the form of hair cracks which are not harmful because they may get closed in course of time, or at least they will not result in serious leakages.

**8.5.2** For analyzing non-circular linings, the stress pattern may be determined using numerical methods.

## **9 GROUND WATER DRAINAGE HOLES**

**9.1** Drainage holes may be provided in other than water conveying tunnels to relieve external pressure, if any, caused by seepage along the outside of the tunnel lining. In free flow tunnels drainage holes may be provided in the crown above the full supply level. In case of pressure tunnels, if the external water pressure is substantially more than the internal water pressure, drainage holes may be provided in the crown. However, when the mountain material is likely to be washed into the tunnel through such drainage holes they shall not be provided.

**9.1.1** The arrangement of drainage holes depends upon the site conditions and shall be decided by the designer. A recommended arrangement is described below:

At successive sections; one vertical hole drilled in the crown alternating with two drilled horizontal holes one in each side wall extending to a depth of at least 15 cm beyond the back of the lining.

**9.1.2** If the flow through the tunnel is conveyed in a separate pipe, the horizontal holes shall be drilled near the invert.

## **10 GROUTING**

**10.1** Grouting shall be in accordance with IS 5878 Part 7.

**10.2 Backfill Grouting** — Backfill grouting shall be done at a pressure not exceeding 5 kg/cm<sup>2</sup> ( $1 Pa = 1.01972 \times 10^{-5} kg/cm^2$ ) and shall be considered as a part of concreting. It shall be done throughout the length of the concrete lining not earlier than 21 days after placement after the concrete in the lining has cooled off. However, stresses developed in concrete at the specified grout pressure may be calculated and seen whether they are within permissible limits depending on the strength attained by concrete by then. The grout pressure mentioned above is the pressure as measured at the grout hole.

NOTE — Backfill grouting serves to fill all voids and cavities between concrete lining and rock.

**10.3 Pressure Grouting** — Pressure grouting shall be done at a maximum practicable pressure consistent with the strength of lining and safety against uplift of overburden. Usually the depth should be between 0.75 *D* and *D*, where *D* is the finished diameter of

the tunnel, except in special reaches where it could be more.

NOTE 1 — Pressure grouting consolidates the surrounding rock and fills any gaps caused by shrinkages of concrete. This grouting is normally specified where lining is reinforced, to improve the rock quality and, therefore, to increase the resistance of rock to carry internal water pressure. As a thumb rule, a grout pressure of 1.5 times the water pressure in the tunnel may be used subject to the conditions that safety against uplift of the overburden is ensured. Grout pressures of up to 5 to 10 times the water pressure in the tunnel have been used internationally.

NOTE 2 — It is advantageous to provide a grout curtain by means of extensive deep grouting at the reservoir end of the tunnel to reduce loss of water due to seepage.

**10.4 Pattern of Holes for Grouting** — For small tunnels, rings of grout holes may be spaced at about 3 m at centres depending upon the nature of the rock. Each ring may consist of four grout holes distributed at about 90° around the periphery, with alternate rings placed vertical and 45° to axis.

**ANNEX A**  
(Clause 6.2)

**BASIC CONDITIONS FOR INCLUDING THE EFFECT OF WATER HAMMER IN THE DESIGN**

**A-1** The basic conditions for including effect of water hammer in the design of tunnels or turbine penstock installations are divided into normal and emergency conditions with suitable factors of safety assigned to each type of operation.

**A-2 NORMAL CONDITIONS OF OPERATIONS**

**A-2.1** The basic conditions to be considered are as follows:

- a) Turbine penstock installation may be operated at any head between the maximum and the minimum values of forebay water surface elevation.
- b) Turbine gates may be moved at any rate of speed by action of the governor head up to a predetermined rate, or at a slower rate by manual control through the auxiliary relay valve.
- c) The turbine may be operating at any gate position, and be required to add or drop; any or all of its load.
- d) If the turbine penstock installation is equipped with any of the following pressure control devices, it will be assumed that these devices are properly adjusted and function in all manner for which the equipment is designed.
  - 1) Surge tanks,
  - 2) Relief valves,
  - 3) Governor control apparatus,
  - 4) Cushioning stroke device, and
  - 5) Any other pressure control device.
- e) Unless the actual turbine characteristics are known, the effective area through the turbine gates during the maximum rate of gate movement will be taken as a linear relation with reference to time.
- f) The water hammer effects shall be computed on the basis of governor head action for the governor rate which is actually set on the turbine for speed regulation. If the relay valve stops are adjusted to give a slower governor setting than that for which the governor is designed, this shall be determined prior to proceeding with the design of turbine penstock installation and later adhered to at the power plant so that an economical basis for designing the penstock scroll case etc., under normal operating conditions may be established.
- g) In those instances, where due to higher reservoir elevation, it is necessary to set the stops on the main relay valve for a slower rate of gate movement, water hammer effects will be computed for this slower rate of gate movement also.



- h) The reduction in head at various points along the penstock will be computed for rate of gate opening which is actually set in the governor in those cases where it appears that the profile of the penstock is unfavorable. This minimum pressure will then be used as a basis for normal design of the penstock to ensure that sub-atmospheric pressures will not cause a penstock failure due to collapse.
- j) If a surge is present in the penstock system, the upsurge in the surge tank will be computed for the maximum reservoir level condition for the rejection of the turbine flow which corresponds to the rated output of the generator during the gate traversing time which is actually set on the governor.
- k) The down surge in the surge tank will be computed for minimum reservoir level condition for a load addition from speed-no-load to the full gate position during the gate traversing time which is actually set on the governor.

### **A-3. EMERGENCY CONDITIONS**

**A-3.1** The basic conditions to be considered as an emergency operation are as follows:

- a) The turbine gates may be closed at any time by the action of the governor head, manual control knob with the main relay valve or the emergency solenoid device.
- b) The cushioning stroke will be assumed to be inoperative.
- c) If a relief valve is present, it will be assumed inoperative.
- d) The gate traversing time will be taken as the minimum time for which the governor is designed.
- e) The maximum head including water hammer at the turbine and along the length of the penstock will be computed for the maximum reservoir head condition for final part gate closure to the zero gate position at the maximum governor rate in  $2L/a$  seconds, where 'L' is length of penstock and 'a' is wave velocity.
- f) If a surge tank is present in the penstock system, the upsurge in the tank will be computed for the maximum reservoir head condition for the rejections of full gate turbine flow at the maximum rate for which the governor is designed. The down surge in the surge tank will be computed for the minimum reservoir head condition for full gate opening from the speed-no-load position at the maximum rate for which the governor is designed. In determining the top and bottom elevations of the surge tank nothing will be added to the upsurge and down surge for this emergency condition of operation.

### **A-4. EMERGENCY CONDITIONS NOT TO BE CONSIDERED AS A BASIS FOR DESIGN**

**A-4.1** The other possible emergency conditions of operation are those during which certain pieces of control are assumed to malfunction in the most unfavorable manner.

The most severe emergency head rise in a turbine penstock installation occurs from either of the two following conditions of operation:

- a) Rapid closure of turbine gates in less than  $2 L/a$  second, when the flow of water in the penstock is maximum.
- b) Rhythmic opening and closing of the turbine gates when a complete cycle of gate operation is performed in  $4 L/a$  second.

Since these conditions of operation require a complete malfunctioning of the governor control apparatus at the most unfavorable moment, the probability of obtaining this type of operation is exceedingly remote. Hence, the conditions shall not be used as a basis for design. However, after the design has been established from other considerations it is desirable that the stresses in the turbine scroll case penstock and pressure control devices not in excess of the ultimate bursting strength or twisting strength of structures for these emergency conditions of operation.

**ANNEX B**  
(Clause 8.4.2.2)

**ROCK LOADS ON TUNNEL LINING**

**B-1. SCOPE**

**B-1.1** This Annex contains recommendations for evaluating rock loads on tunnel lining.

**B-2. LOAD DISTRIBUTION**

**B-2.1** Rock load may be assumed as an equivalent uniformly distributed load over the tunnel soffit over a span equal to the tunnel width or diameter as the case may be.

**B-3. LOAD**

**B-3.1** Rock loads may be estimated by any of the methods given in **B-3.1.1** to **B-3.1.3**.

**B-3.1.1** Rock load at depths less than or equal to  $1.5 (B + H_t)$  may be taken as equal to depth of actual rock cover where  $B$  is the width and  $H_t$  is the height of the tunnel opening. In case of circular tunnels  $B$  and  $H_t$  both will be equal to the diameter of tunnel  $D$ .

Rock load ( $H_p$ ) on the roof of support in tunnel with width  $B$  and height  $H_t$  at depth of more than  $1.5 (B + H_t)$  may be assumed to be according to Table 1.

**B-3.1.2** Rock load may also be worked out using Fenner's ellipse (see Fig. 9) by the following equation:

$$a = \frac{b(m-2)}{2} b(m-2)$$

Where

$a$  = main axis of ellipse of rock load,

$b$  = tunnel diameter (excavated), and

$m$  = inverse of Poisson's ratio for rock (which usually varies from 2 to 7).

The weight of rock in the shaded portion may be taken as rock load and may be considered as uniformly distributed on the diameter of tunnel.

NOTE — The above treatment assumes the rock to be homogeneous and to behave within elastic range. It has also limited application as it does not give any rock loads for value of Poisson's ratio equal to 0.25 and above. It does not also take into consideration the strength and characteristics of rock.

**B-3.1.3** The rock load according to the Russian practice depends upon the degree of rock firmness. The rock load may be taken as that for rock area enclosed by a parabola starting from intersection points of the rupture planes with horizontal length drawn to the crown of the tunnel section. The dimensions of the parabola are given below (see Fig. 5):

$$h = \frac{B}{2f}$$

$$B = b + [2m \tan(45^\circ - \phi/2)]$$

Where

$\phi$  = ~~friction angle of rock mass~~ ~~the angle of repose of the soil~~, and

$f$  = the strength factor after Protodyakonov (see Table 2).

In the case of circular tunnels,  $B = D[1 + 2 \tan(45^\circ - \phi/2)]$

Where,  $D$  = diameter of the finished tunnel.

**TABLE 1 ROCK LOAD**  
(Clause B-3.1.1)

Sl. No.	Rock Condition	Rock Load, $H_p$ m	Remarks
1	Hard and intact	Zero	Light lining required only if spalling or popping occurs
2	Hard stratified or schistose	0 to 0.50 B	Light support
3	Massive, moderately Jointed	0 to 0.25 B	Load may change erratically from point to point
4	Moderately blocky and seamy	0.25 B to 0.35 (B+H)	No side pressure
5	Very blocky and seamy	(0.35 to 1.10) (B+H)	Little or no side pressure
6	Completely crushed but chemically intact	1.10 (B+ H)	Considerable side pressure. Softening effect of seepage towards bottom of tunnel. Requires either continuous support for lower ends of ribs or circular ribs.
7	Squeezing rock, moderate depth	(1.10 to 2.10) (B+ H)	Heavy side pressure. Invert struts required. Circular ribs are recommended.
8	Squeezing rock, great depth	(2.10 to 4.50) (B+ H)	
9	Swelling rock	Up to 80 m irrespective of value of (B+ H)	Circular ribs required. In extreme cases use yielding support.

NOTE 1 — The above Table has been arrived on the basis of observation and behavior of supports in Alpine tunnels where the load was derived mainly on loosening type of rock.

NOTE 2 — The roof of the tunnel is assumed to be located below the water table. If it is located permanently above the water table, the values given for types 4 to 6 may be reduced by 50 percent.

NOTE 3 — Some of the most common rock formations contain layers of shale. In an unweathered state, real shales are no worse than other stratified rocks. However, the term shale is often applied to firmly compacted clay sediments which have not yet acquired the properties of rock. Such so called shales may behave in the tunnel like squeezing or even swelling rock. Such so called shales may behave in the tunnel like squeezing or even swelling rock.

NOTE 4 — If rock formation consists of sequence of horizontal layers of sand stone or lime stone and of immature shale, the excavation of the tunnel is commonly associated with a gradual compression of the rock on the both sides of the tunnel, involving a downward movement of the roof. Furthermore, the relatively low resistance against slippage at the boundaries between the so called shale and rock is likely to reduce very considerably the capacity of rock located above the roof to bridge. Hence, in such rock formations, the roof pressure may be as heavy as in a very blocky and seamy rock.

**TABLE 2 STRENGTH FACTORS**

(Clause B-3.1.3)

Category	Strength Grade	Denotation of Rock (Soil)	Unit Weight (kg/m <sup>3</sup> )	Crushing Strength (kg/cm <sup>2</sup> )	Strength Factor (f)
(1)	(2)	(3)	(4)	(5)	(6)
I	Highest	Solid, dense quartzite, basalt, and other solid rocks of exceptionally high strength.	2800-3000	2000	20
II	Very high	Solid, granite, quartzporphyr, silica shale. Highly resistive sandstones and limestones.	2600-2700	1500	15
III	High	Granite and alike, very resistive sand and limestones, quartz, solid conglomerated.	2500-2600	1000	15
IIIa	High	Limestones, weathered granite, solid sandstone, marble.	2500	800	8
IV	Moderately strong	Normal sandstone	2400	600	6
IVa	Moderately strong	Sandstone shales.	2300	500	5
V	Medium	Clay-shales, sand and Lime stones of smaller resistance. Loose conglomerates.	2400-2600	400	4
Va	Medium	Various shales and slates, dense marl	2400-2800	300	3

VI	Moderately loose	Loose shale and very loose limestone, gypsum, frozen ground, common marl. Blocky sandstones, cemented gravel and boulders, Stoney ground	2200-2600	200 -150	2
Vla	Moderately loose	Gravelly ground, Blocky and fissured shale, compressed boulders and gravel, hard clay	2200-2400	-	1.5
VII	Loose	Dense clay, cohesive ballast clayey ground	2000-2200	-	1.0
VIIa	Loose	Loose loam, loess, gravel.	1800-2000	-	0.8
VIII	Soils	Soil with vegetation peat, soft loam, wet sand.	1600-1800	-	0.6
IX	Granular soils	Sand, fine gravel, upfill	1400-1600	-	0.5
X	Plastic soils	Silty ground, modified looses and other soils in liquid condition	-	-	0.3

The load maybe taken as uniformly distributed over the diameter of the tunnel.

NOTE — The above is applicable when the distance between the vertex of the pressure parabola from the bottom of the weak layer or from the ground surface is not less than h. However, where this conditions is not fulfilled the total value of rock load maybe assumed.

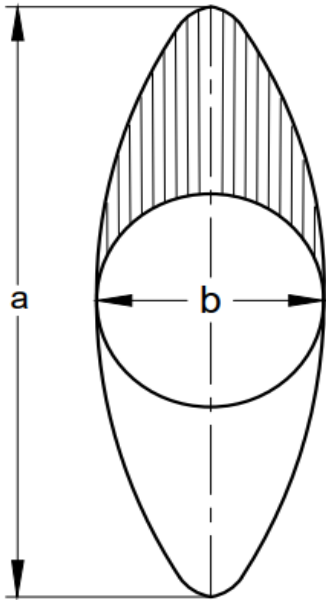

FIG. 4 FENNER'S ELLIPSE

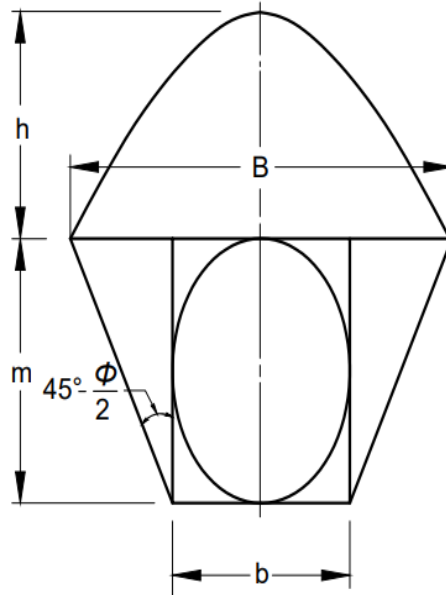

FIG. 5 ASSUMED ROCK LOAD ON A CIRCULAR CAVITY

**ANNEX C**

(Clause 8.4.1 and Clause 8.4.6.2)

**FORMULAE FOR VALUES OF BENDING MOMENTS, NORMAL THRUST, RADIAL SHEAR, HORIZONTAL AND VERTICAL DEFLECTION**

**C-1.** The values of bending moment, normal thrust, radial shear and horizontal and vertical deflection for the loading pattern shown in Fig. 3 are given in Table 3 to 7.

**C-2.** For purpose of this Annex, the following notations shall apply:

$E$	=	young's modulus of the lining material,
$I$	=	moment of inertia of the section,
$K$	=	intensity of lateral triangular load at horizontal diameter,
$P$	=	total rock load on mm diameter,
$r$	=	internal radius of tunnel,
$R$	=	mean radius of tunnel lining,
$t$	=	thickness of lining,
$W$	=	unit weight of water,
$W_c$	=	unit weight of concrete, and
$\phi$	=	angle that the section makes with the vertical diameter at the center measured from invert.

**C-3** For the purpose of this annex, the following sign conventions shall apply:

- Positive moment indicates tension on inside face and compression on outside face,
- Positive thrust means compression on the section,
- Positive shear means that considering left half of the ring the sum of all the forces on the left of the section acts outwards when viewed from inside,
- Positive horizontal deflection means outward deflection with reference to center of conduit, and
- Positive vertical deflection means downward deflection.

**TABLE 3 VALUES OF BENDING MOMENTS**

(Clause C-1)

$\phi$	Uniform Vertical Load	Conduit Weight	Contained Water	Lateral Pressure
0	+0.1250 PR	+0.4406 $W_c . t . R^2$	+ 0.2203 $W . r^2 . R$	- 0.1434 $K . R^2$
$\frac{\pi}{4}$	Zero	-0.0334 $W_c . t . R^2$	- 0.0167 $W . r^2 . R$	- 0.0084 $K . R^2$
$\frac{\pi}{2}$	- 0.1250 PR	- 0.3927 $W_c . t . R^2$	-0.1963 $W . r^2 . R$	+0.1653 $K . R^2$
$\frac{3\pi}{4}$	Zero	+ 0.0334 $W_c . t . R^2$	+0.0167 $W . r^2 . R$	-0.0187 $K . R^2$
$\pi$	+ 0.1250 PR	+0.3448 $W_c . t . R^2$	+0.1724 $W . r^2 . R$	- 0.1295 $K . R^2$



**TABLE 4 VALUES OF NORMAL THRUST**  
(Clause C-1)

$\theta$	Uniform Vertical Load	Conduit Weight	Contained Water	Lateral Pressure
0	Zero	+0.166 7 $W_c .t.R$	- 1.416 6 $W.r^2$	+ 0.475 4 $K.R$
$\frac{\pi}{4}$	+ 0.250 0 P	+1.133 2 $W_c .t.R$	- 0.786 9 $W.r^2$	+ 0.305 8 $K.R$
$\frac{\pi}{2}$	+ 0.500 0 P	+ 1.570 8 $W_c .t.R$	-0.214 6 $W.r^2$	Zero
$\frac{3\pi}{4}$	+0.250 0 P	+ 0.437 6 $W_c .t.R$	-0.427 7 $W.r^2$	+0.267 4 $K.R$
$\pi$	Zero	-0.166 7 $W_c .t.R$	-0.583 4 $W.r^2$	+0.378 2 $K.R$

**TABLE 5 VALUES OF RADIAL SHEAR**  
(Clause C-1)

$\theta$	Uniform Vertical Load	Conduit Weight	Contained Water	Lateral Pressure
0	Zero	Zero	Zero	Zero
$\frac{\pi}{4}$	- 0.250 0 P	-0.897 6 $W_c .t.R$	- 0.448 8 $W.r^2$	+ 0.305 8 $K.R$
$\frac{\pi}{2}$	Zero	+ 0.1667 $W_c .t.R$	+0.0833 $W.r^2$	-0.0246 $K.R$
$\frac{3\pi}{4}$	+0.250 0 P	+ 0.6732 $W_c .t.R$	+0.3366 $W.r^2$	-0.267 4 $K.R$
$\pi$	Zero	Zero	Zero	Zero

**TABLE 6 VALUES OF HORIZONTAL DEFLECTION**  
(Clause C-1)

$\theta$	Uniform Vertical Load	Conduit Weight	Contained Water	Lateral Pressure
0	Zero	Zero	Zero	Zero
$\frac{\pi}{4}$	+ 0.014 73 $\frac{PR^3}{EI}$	+0.050 40 $\frac{W_c tR^4}{EI}$	+0.025 20 $\frac{Wr^2R^3}{EI}$	-0.017 50 $\frac{KR^4}{EI}$

$\frac{\pi}{2}$	$+ 0.041\ 67 \frac{PR^3}{EI}$	$+0.130\ 90 \frac{W_c tR^4}{EI}$	$+0.065\ 45 \frac{Wr^2 R^3}{EI}$	$-0.050\ 55 \frac{KR^4}{EI}$
$\frac{3\pi}{4}$	$+ 0.014\ 73 \frac{PR^3}{EI}$	$+0.042\ 16 \frac{W_c tR^4}{EI}$	$+0.021\ 08 \frac{Wr^2 R^3}{EI}$	$-0.016\ 24 \frac{KR^4}{EI}$
$\pi$	Zero	Zero	Zero	Zero

**TABLE 7 VALUES OF VERTICAL DEFLECTION**  
(Clause C-1)

$\emptyset$	Uniform Vertical Load	Conduit Weight	Contained Water	Lateral Pressure
0	Zero	Zero	Zero	Zero
$\frac{\pi}{4}$	$+ 0.026\ 94 \frac{PR^3}{EI}$	$+0.092\ 79 \frac{W_c tR^4}{EI}$	$+0.046\ 40 \frac{Wr^2 R^3}{EI}$	$-0.031\ 76 \frac{KR^4}{EI}$
$\frac{\pi}{2}$	$+ 0.041\ 67 \frac{PR^3}{EI}$	$+0.139\ 17 \frac{W_c tR^4}{EI}$	$+0.069\ 58 \frac{Wr^2 R^3}{EI}$	$-0.049\ 95 \frac{KR^4}{EI}$
$\frac{3\pi}{4}$	$+ 0.056\ 40 \frac{PR^3}{EI}$	$+0.185\ 35 \frac{W_c tR^4}{EI}$	$+0.092\ 68 \frac{Wr^2 R^3}{EI}$	$-0.068\ 10 \frac{KR^4}{EI}$
$\pi$	$+ 0.083\ 33 \frac{PR^3}{EI}$	$+0.261\ 80 \frac{W_c tR^4}{EI}$	$+0.130\ 90 \frac{Wr^2 R^3}{EI}$	$-0.097\ 39 \frac{KR^4}{EI}$

Formatted: Justified

## ANNEX D (Clause 8.5.1)

### BASIC EQUATIONS FOR ANALYSIS OF TUNNEL LINING CONSIDERING TUNNEL AND THE SURROUNDING ROCK AS A COMPOSITE CYLINDER

#### D-1 SCOPE

**D-1.1** This Annex contains basic equations for calculating radial and tangential stresses in concrete lining and the surrounding rock mass considering both as parts of composite cylinder.

#### D-2 NOTATIONS

**D-2.1** For this Annex the following notations shall apply:

$p$	=	internal hydrostatic pressure (negative compression),
$\sigma_1, \sigma_2, \sigma_3$	=	tangential stress in rock, concrete and steel respectively,
$\bar{\sigma}_1, \bar{\sigma}_2, \bar{\sigma}_3$	=	radial stress in rock, concrete and steel respectively,
$E_1, E_2, E_3$	=	modulus of elasticity of rock, concrete and steel respectively,
$m_1, m_2$	=	<u>inverse of</u> poisson's <u>ratio</u> number of rock, and concrete
respectively,		
$U_1, U_2, U_3$	=	radial deformation in rock, concrete and steel respectively,
$x$	=	radius of element,
$B$ & $C$ , etc.	=	integration constants,
$A_s$	=	areas of reinforcement per unit length of tunnel,
$a$	=	internal radius of the tunnel, and
$b$	=	external radius of the lining up to A-line.

#### D-3 BASIC EQUATIONS

##### D-3.1 Plain Cement Concrete Lining Considering that it is not Cracked.

a) Basic equations:

$$\sigma_r = \frac{mE}{m^2 - 1} \left[ B(m+1) - \frac{C}{x^2}(m-1) \right]$$

$$\sigma_r = \frac{mE}{m^2 - 1} \left[ B(m+1) - \frac{C}{x^2}(m-1) \right]$$

$$\sigma_t = \frac{mE}{m^2 - 1} \left[ B(m+1) + \frac{C}{x^2}(m-1) \right]$$

$$U = Bx + C/x$$

$$\sigma_t = \frac{mE}{m^2 - 1} \left[ B(m+1) + \frac{C}{x^2}(m-1) \right]$$

Formatted: Justified

Formatted: Indent: Left: 0", First line: 0"

$$U = Bx + \frac{C}{x}$$

NOTE — Tensile stress is positive in the derivation of above formula which is opposite to sign convention adopted in concrete design.

b) Limit conditions and constants:

- 1) When  $x = \infty$        ~~$\sigma_{r1} = 0$~~   $\sigma_{r1} = 0$
- 2) When  $x = b$  ,       ~~$\sigma_{r1} = \sigma_{r2}$~~   $\sigma_{r1} = \sigma_{r2}$
- 3) When  $x = a$  ,       ~~$\sigma_{r2} = -p$~~   $\sigma_{r2} = -p$
- 4) When  $x = b$  ,       ~~$U_1 = U_2$~~   $U_1 = U_2$

### D-3.2 Plain Cement Concrete Lining Considering that it is Cracked

a) Basic equations for rock:

$$\sigma_{r1} = \frac{m_1 E_1}{m_1^2 - 1} \left[ B_1 (m_1 + 1) - \frac{C_1}{x^2} (m_1 - 1) \right]$$

$$\sigma_{t1} = \frac{m_1 E_1}{m_1^2 - 1} \left[ B_1 (m_1 + 1) + \frac{C_1}{x^2} (m_1 - 1) \right]$$

b) For concrete:

$$\sigma_{r2} = \frac{a \cdot (\sigma_{r2})_{x=a}}{x}$$

$$\sigma_{r2} = 0 \quad \sigma_{t2} = 0 \quad \text{(s(since concrete does not take any tangential stress))}$$

c) Limit conditions:

- 1) When  $x = \infty$        $\sigma_{r1} = 0$
- 2) When  $x = b$  ,       $\sigma_{r1} = \sigma_{r2}$
- 3) When  $x = a$  ,       $\sigma_{r2} = -p$

d) Constants are calculated as:

$$B_1 = 0$$

$$C_1 = \frac{a \cdot b \cdot p \cdot (m_1 + 1)}{m_1 E_1}$$

$$(\sigma_{r2})_{x=a} = -p$$

Formatted: Justified

Formatted: Centered

Formatted: Justified, Indent: Left: 0.75", First line: 0"

Formatted: Font: 10 pt, Not Bold, Complex Script Font: 10 pt, Bold

Formatted: Font: 12 pt, Complex Script Font: 12 pt

Formatted: Font: 12 pt, Complex Script Font: 12 pt

Formatted: Font: 12 pt, Complex Script Font: 12 pt

Formatted: Font: 12 pt, Complex Script Font: 12 pt

Formatted: Font: 12 pt, Complex Script Font: 12 pt

Formatted: Font: 12 pt, Complex Script Font: 12 pt

Formatted: Font: 12 pt, Complex Script Font: 12 pt

Formatted: Font: 12 pt, Complex Script Font: 12 pt

Formatted: Font: 12 pt, Complex Script Font: 12 pt

Formatted: Font: 12 pt, Complex Script Font: 12 pt

Formatted: Font: 12 pt, Complex Script Font: 12 pt

Formatted: Font: 12 pt, Complex Script Font: 12 pt

Formatted: Font: 12 pt, Complex Script Font: 12 pt

Formatted: Font: 12 pt, Complex Script Font: 12 pt

Formatted: Font: 12 pt, Complex Script Font: 12 pt

Formatted: Font: 12 pt, Complex Script Font: 12 pt

Formatted: Font: 12 pt, Complex Script Font: 12 pt

Formatted: Font: 12 pt, Complex Script Font: 12 pt

Formatted: Font: 12 pt, Complex Script Font: 12 pt

Formatted: Font: 12 pt, Complex Script Font: 12 pt

Formatted: Font: 12 pt, Complex Script Font: 12 pt

Formatted: Font: 12 pt, Complex Script Font: 12 pt

Formatted: Font: 12 pt, Complex Script Font: 12 pt

Formatted: Font: 12 pt, Complex Script Font: 12 pt

Formatted: Font: 12 pt, Complex Script Font: 12 pt

Formatted: Font: 12 pt, Complex Script Font: 12 pt

Formatted: Font: 12 pt, Complex Script Font: 12 pt

Formatted: Font: 12 pt, Complex Script Font: 12 pt

Formatted: Font: 12 pt, Complex Script Font: 12 pt

Formatted: Font: 12 pt, Complex Script Font: 12 pt

Formatted: Font: 12 pt, Complex Script Font: 12 pt

Formatted: Font: 12 pt, Complex Script Font: 12 pt

Formatted: Font: 12 pt, Complex Script Font: 12 pt

Formatted: Font: 12 pt, Complex Script Font: 12 pt

Formatted: Font: 12 pt, Complex Script Font: 12 pt

Formatted: Font: 12 pt, Complex Script Font: 12 pt

Formatted: Font: 12 pt, Complex Script Font: 12 pt

Formatted: Font: 12 pt, Complex Script Font: 12 pt

Formatted: Font: 12 pt, Complex Script Font: 12 pt

Formatted: Font: 12 pt, Complex Script Font: 12 pt

Formatted: Font: 12 pt, Complex Script Font: 12 pt

Formatted: Font: 12 pt, Complex Script Font: 12 pt

Formatted: Font: 12 pt, Complex Script Font: 12 pt

Formatted: Font: 12 pt, Complex Script Font: 12 pt

Formatted: Font: 12 pt, Complex Script Font: 12 pt

Formatted: Font: 12 pt, Complex Script Font: 12 pt

Formatted: Font: 12 pt, Complex Script Font: 12 pt

Formatted: Font: 12 pt, Complex Script Font: 12 pt

Formatted: Justified

**D-3.3 Plain Cement Concrete Lining Considering that it is Cracked and Surrounding Rock also is Cracked for a Distance Equal to Radius Beyond Which Rock is Massive and Uncracked.**

a) For concrete:

$$\sigma_{r2} = \frac{a \cdot (\sigma_{r2})_{x=a}}{x} \quad a \leq x \leq b$$

$$\sigma_{t2} = 0 \quad a \leq x \leq b$$

b) For cracked rock:

$$\sigma_{r1} = \frac{a \cdot (\sigma_{r2})_{x=a}}{x} \quad b \leq x \leq b'$$

$b'$  = extent of the cracked rock diameter beyond A-line ( $\frac{b'}{b}$  may be conservatively taken as 2 for preliminary design)

$$\sigma_{t1} = 0 \quad b \leq x \leq b'$$

NOTE — Symbol  $\sigma_{r1}'$  and  $\sigma_{t1}'$  refer to cracked zone of rock.

c) For surrounding uncracked rock:

$$\sigma_{r1} = \frac{m_1 E_1}{m_1^2 - 1} \left[ B_1 (m_1 + 1) - \frac{C_1}{x^2} (m_1 - 1) \right]$$

$$\sigma_{t1} = \frac{m_1 E_1}{m_1^2 - 1} \left[ B_1 (m_1 + 1) + \frac{C_1}{x^2} (m_1 - 1) \right]$$

d) Limit conditions:

- 1) At  $x = \infty$        $\sigma_{r1} = 0$
- 2) At  $x = y$ ,       $\sigma_{r1}' = \sigma_{r1}$
- 3) At  $x = b$ ,       $\sigma_{r2} = \sigma_{r1}'$
- 4) At  $x = a$ ,       $\sigma_{r2} = -p$

Formatted: Font: 14 pt, Complex Script Font: 14 pt

Formatted: Font: 14 pt, Complex Script Font: 14 pt

Formatted: Font: 16 pt, Complex Script Font: 16 pt

Formatted: Font: 16 pt, Complex Script Font: 16 pt

Formatted: Font: 16 pt, Complex Script Font: 16 pt

Formatted: Font: 16 pt, Complex Script Font: 16 pt

Formatted: Font: 16 pt, Complex Script Font: 16 pt

Formatted: Font: 16 pt, Complex Script Font: 16 pt

Formatted: Font: 16 pt, Complex Script Font: 16 pt

Formatted: Font: 16 pt, Complex Script Font: 16 pt

Formatted: Font: 16 pt, Complex Script Font: 16 pt

Formatted: Font: 16 pt, Complex Script Font: 16 pt

Formatted: Font: 16 pt, Complex Script Font: 16 pt

Formatted: Font: 16 pt, Complex Script Font: 16 pt

Formatted: Font: 16 pt, Complex Script Font: 16 pt

Formatted: Font: 16 pt, Complex Script Font: 16 pt

Formatted: Font: 16 pt, Complex Script Font: 16 pt

Formatted: Font: 16 pt, Complex Script Font: 16 pt

Formatted: Font: 16 pt, Complex Script Font: 16 pt

**D-3.4 Reinforced Cement Concrete Lining Considering that it is not Cracked**

a) Basic equations:

$$\sigma_r = \frac{mE}{m^2 - 1} \left[ B_1 B (m + 1) - \frac{C_1}{x^2} (m - 1) \right]$$

$$\sigma_t = \frac{m^2 E}{m^2 - 1} \left[ B_1 (m + 1) + \frac{C_1}{x^2} (m - 1) \right]$$

$$U = Bx + C/x$$

$$\sigma_{t3} = \frac{E_3}{a} (B_2 a + \frac{C_2}{a})$$

$$\sigma_{r3} = \frac{E_3 A_s}{a^2} (B_2 a + \frac{C_2}{a})$$

b) Limit conditions and constants:

- 1) At  $x = \infty$   $\sigma_{r1} = 0$
- 2) At  $x = b$   $\sigma_{r1} = \sigma_{r2}$
- 3) At  $x = a$ ,  $\sigma_{r2} - \sigma_{r3} = -p$
- 4) At  $x = b$ ,  $U_1 = U_2$

c) Constants are given by:

$$C_1 = B_2 b^2 + C_2$$

$$C_1 = \left\{ \frac{E_2 m_2 (m_1 + 1)}{E_1 m_1 (m_2 + 1)} \right\} C_2 - \left\{ \frac{E_2 m_2 (m_1 + 1)^2}{E_1 m_1 (m_2 - 1)} \right\} B_2 b^2$$

$$-p = B_2 \left\{ \frac{E_2 m_2}{m_2 - 1} - \frac{E_3 A_s}{a} \right\} - \left\{ \frac{E_2 m_2}{a^2 (m_2 + 1)} + \frac{E_3 A_s}{a^3} \right\} C_2$$

**D-3.5 Reinforced Cement Concrete Lining** — Considering that it is cracked and because of radial cracks it cannot take tangential tensile stress

a) Basic equations for rock

$$\sigma_{t1} = \frac{E_1 m_1^2 m_2 C_1}{(m_1 + 1)^2 (m_1 + 1) x^2}$$

$$\sigma_{r1} = -\sigma_{t1}$$

$$U_1 = \frac{C_1}{x}$$

b) Basic equations for concrete

$$\sigma_{t2} = 0$$

$$\sigma_{r2} = \frac{a \cdot (\sigma_{r2})_{x=a}}{x}$$

$$U_2 = \frac{a \cdot (\sigma_{r2})_{x=a}}{E_2} \cdot \log(b/a)$$

c) Basic equations for steel

$$\sigma_{t3} = \frac{a \cdot \sigma_{r3}}{A_s}$$
$$\sigma_{r3} = \frac{E_3 A_s}{a^2} \left( B_2 \cdot a + \frac{C_2}{a} \right)$$
$$U_3 = \frac{a^2 \sigma_{r3}}{E_3 A_s}$$

d) Constants of integration

$$(\sigma_{r2})_{x=a} = \frac{-p a m_1 E_1 E_2}{a m_1 E_1 E_2 + m_1 E_1 E_3 A_s \log(b/a) + (m_1 + 1) E_2 E_3 A_s}$$

$$C_1 = \frac{-a b (m_1 + 1) (\sigma_{r2})_{x=a}}{m_1^2 m_2 E_1}$$

$$\sigma_{r3} = (\sigma_{r2})_{x=(a+p)}$$