**Determination of organonitrogen
compounds in air using liquid
chromatography and mass spectrometry**

Part 1:

Isocyanates using dibutylamine derivatives

*Détermination des composés organiques azotés dans l'air par
chromatographie liquide et spectrométrie de masse*

Partie 1: Isocyanates par les dérivés de la dibutylamine

Copyright notice

This ISO document is a Draft International Standard and is copyright-protected by ISO. Except as permitted under the applicable laws of the user's country, neither this ISO draft nor any extract from it may be reproduced, stored in a retrieval system or transmitted in any form or by any means, electronic, photocopying, recording or otherwise, without prior written permission being secured.

Requests for permission to reproduce should be addressed to either ISO at the address below or ISO's member body in the country of the requester.

ISO copyright office
Case postale 56 • CH-1211 Geneva 20
Tel. + 41 22 749 01 11
Fax + 41 22 749 09 47
E-mail copyright@iso.org
Web www.iso.org

Reproduction may be subject to royalty payments or a licensing agreement.

Violators may be prosecuted.

Contents	Page
Foreword	4
Introduction	5
1 Scope	2
2 Normative references	2
3 Principle	3
4 Reagents and materials	4
5 Preparation of standard solutions	5
6 Apparatus	9
7 Air sampling	12
8 Laboratory sample preparation	15
9 Instrumental settings	16
10 Data handling	17
11 Interferences	18
12 Determination of performance characteristics	18
Annex A (informative) Performance characteristics	27
A.1 Uncertainty estimates	27
A.2 Combined uncertainty	27
A.3 Expanded uncertainty	28
Annex B (informative) Examples	29
B.1 Example 1: Gluing	29
B.2 Example 2: Welding in PUR-coated car metal sheets	30
B.3 Example 3: Casting in sand moulds	31
B.4 Example 4: Mass spectra of isocyanate-DBA derivatives	32
Annex C (informative) Commercially available products	34
Bibliography	35

Foreword

ISO (the International Organization for Standardization) is a worldwide federation of national standards bodies (ISO member bodies). The work of preparing International Standards is normally carried out through ISO technical committees. Each member body interested in a subject for which a technical committee has been established has the right to be represented on that committee. International organizations, governmental and non-governmental, in liaison with ISO, also take part in the work. ISO collaborates closely with the International Electrotechnical Commission (IEC) on all matters of electrotechnical standardization.

The procedures used to develop this document and those intended for its further maintenance are described in the ISO/IEC Directives, Part 1. In particular the different approval criteria needed for the different types of ISO documents should be noted. This document was drafted in accordance with the editorial rules of the ISO/IEC Directives, Part 2 (see www.iso.org/directives).

Attention is drawn to the possibility that some of the elements of this document may be the subject of patent rights. ISO shall not be held responsible for identifying any or all such patent rights. Details of any patent rights identified during the development of the document will be in the Introduction and/or on the ISO list of patent declarations received (see www.iso.org/patents).

Any trade name used in this document is information given for the convenience of users and does not constitute an endorsement.

For an explanation on the meaning of ISO specific terms and expressions related to conformity assessment, as well as information about ISO's adherence to the WTO principles in the Technical Barriers to Trade (TBT) see the following URL: [Foreword - Supplementary information](#)

The committee responsible for this document is ISO/TC 146, *Air quality*, Subcommittee SC 2, *Workplace atmospheres*.

This second edition of ISO 17734-1 cancels and replaces ISO 17734-1:2006, which has been technically revised.

ISO 17734 consists of the following parts, under the general title *Determination of organonitrogen compounds in air using liquid chromatography and mass spectrometry*:

- *Part 1: Isocyanates using dibutylamine derivatives*
- *Part 2: Amines and aminoisocyanates using dibutylamine and ethyl chloroformate derivatives*

Introduction

Isocyanates have been used in industry for about 50 years. They are commercially important chemicals mainly used for the production of polyurethane (PUR). In spite of controls to limit exposures, there are adverse health effects such as asthma, contact dermatitis, and hypersensitivity pneumonitis as consequences of exposure to isocyanates in some industrial sectors.

The analytical method for the determination of isocyanates in workplace air must be sensitive due to the high irritation and sensitization properties of isocyanates. Extremely low occupational exposure limits (OELs) exist in many countries, and concentrations well below the OEL ($< 1/100$) are often to be determined. Isocyanates are very reactive and therefore cannot be analysed directly. Derivatization during sampling is required in order to prevent interfering reactions. Hundreds of different isocyanates are used in industry, and many more are formed during thermal degradation of PUR. Therefore, high selectivity of the analytical method is required for accurate results.

The determination of isocyanates in the work environment using di-*n*-butylamine (DBA) as a reagent and liquid chromatography-mass spectrometric detection (LC-MS) has been demonstrated to be a robust method. The development of the method was initiated when difficulties using the “older” methods during sampling of isocyanates in complex atmospheres were encountered (e.g. thermal decomposition of PUR).^{[1][2][3]} The reaction rate between DBA and isocyanates was found to be fast, and high concentrations can be used to secure instantaneous reactions and eliminate problems with interfering compounds.^{[4][5]} Using impinger flasks containing a reagent solution and a filter in series efficiently collects and derivatizes isocyanates in both the gas and the particle phase.^[6] LC-MS/MS of the isocyanate-DBA derivatives enables highly selective and precise determinations down to levels below 10^{-6} of the OEL.^[7]

Solvent-free sampling can also be performed by using a tube coated with a DBA-impregnated glass fibre filter followed by an impregnated filter. An impregnation solution containing DBA together with an acid is used, and the formed ion pair reduces volatility. DBA remains on the filter even after 8 h of sampling.^[8]

Monomeric isocyanates that are formed during thermal decomposition of polymers [typically PUR and phenol/formaldehyde/urea (PFU) resins], such as isocyanic acid and methyl isocyanate, can also be determined.^{[6][7][8][9][10]} Volatile isocyanate-DBA derivatives can be determined using gas chromatography-mass spectrometric detection (GC-MS).^[9] Using the DBA method and derivatization with ethyl chloroformate makes simultaneous determinations of amine, aminoisocyanates, and isocyanates possible, as described in the companion method ISO 17734-2.

For quantification, reference compounds are necessary but are only available for a few monomeric isocyanates. Most of the isocyanates that are used in industry for the production of PUR can only be obtained in technical grade mixtures. Many isocyanates that are formed during thermal degradation are not available and are not easily synthesized. In this method, a nitrogen-sensitive detector has been used for quantifying isocyanates in reference solutions. This technique has been demonstrated to be a useful tool, together with MS characterization, in greatly facilitating the production of reference solutions.^{[10][11][12]}

For quantifying isocyanates in complex mixtures, MS detection appears to be the current best available detection technique and provides a unique possibility of identifying unknown compounds. This method has enabled assessment of new areas for which exposure to isocyanates was not known previously and has identified new kinds of isocyanates in the work environment.^{[6][7][8][9][10][11][12]}

Workplace atmospheres — Determination of organonitrogen compounds in air using liquid chromatography and mass spectrometry —

Part 1: Isocyanates using dibutylamine derivatives

1 Scope

This part of ISO 17734 gives general guidance for the sampling and analysis of airborne isocyanates in workplace air. When amines and aminoisocyanates are suspected to be emitted (e.g. from thermal degradation of PUR), it is recommended that, in addition to isocyanates, the amines and aminoisocyanates in the air are determined, using DBA and ethyl chloroformate as reagents (see ISO 17734-2).

The method is suitable for the determination of a wide range of different isocyanates in both the gas and particle phases. Typical monofunctional isocyanates that can be determined are isocyanic acid (ICA), methyl isocyanate (MIC), ethyl isocyanate (EIC), propyl isocyanate (PIC), butyl isocyanate (BIC), and phenyl isocyanate (PhI). Typical monomeric diisocyanates include 1,6-hexamethylene diisocyanate (HDI), 2,4- and 2,6-toluene diisocyanate (TDI), 4,4'-methylenediphenyl diisocyanate (MDI), 1,5-naphthyl diisocyanate (NDI), isophorone diisocyanate (IPDI), and 4,4'-dicyclohexylmethane diisocyanate (HMDI). Multifunctional isocyanates that can be determined are typically oligomers in polymeric MDI, biuret-, isocyanurate-, and allophanate-adducts, and prepolymeric forms of isocyanates.

The useful range is approximately 2,5 ng to 500 ng of isocyanate per sample. For a 15 l air sample, this corresponds to 0,2 µg/m³ to 33 µg/m³. These values may slightly change according to the isocyanate analysed.

2 Normative references

The following documents, in whole or in part, are normatively referenced in this document and are indispensable for its application. For dated references, only the edition cited applies. For undated references, the latest edition of the referenced document (including any amendments) applies.

ISO 5725-2, *Accuracy (trueness and precision) of measurement methods and results — Part 2: Basic method for the determination of repeatability and reproducibility of a standard measurement method*

ISO 16200-1, *Workplace air quality — Sampling and analysis of volatile organic compounds by solvent desorption/gas chromatography — Part 1: Pumped sampling method*

ICS 13.040.30

Price based on 29 pages

3 Principle

Samples are collected by drawing a known volume of air through a midjet impinger flask followed by a filter. The impinger contains 10 ml of 0,01 mol·l⁻¹ of DBA in toluene and the filter is a glass fibre filter with no binder.

Solvent-free sampling can also be performed by drawing air through a tube coated with a DBA-impregnated glass fibre filter followed by an impregnated filter. An impregnation solution containing DBA together with acetic acid is used, the ion pair so formed reduces the volatility and enables long-time sampling.

After sampling, deuterium-labelled isocyanate-DBA derivatives (used as internal standard) are added to the sample solutions. The excess reagent and solvent are evaporated, and the samples are dissolved in acetonitrile. The samples are analysed using reversed-phase LC and electrospray (ESP)-MS detection, monitoring positive ions. Quantification is made by monitoring selected ions. See Figure 1.

Quantification and qualitative determinations can be performed using different LC-MS or LC-MS/MS techniques. Liquid chromatography-chemiluminescent nitrogen detection (LC-CLND), or liquid chromatography-ultraviolet detection (LC-UV) for aromatic isocyanates, can be used for the determination of higher concentrations of isocyanates.

Reference materials can be characterized using LC-MS/CLND. For characterization of volatile compounds, gas chromatography-thermionic specific detector (GC-TSD) can also be used.

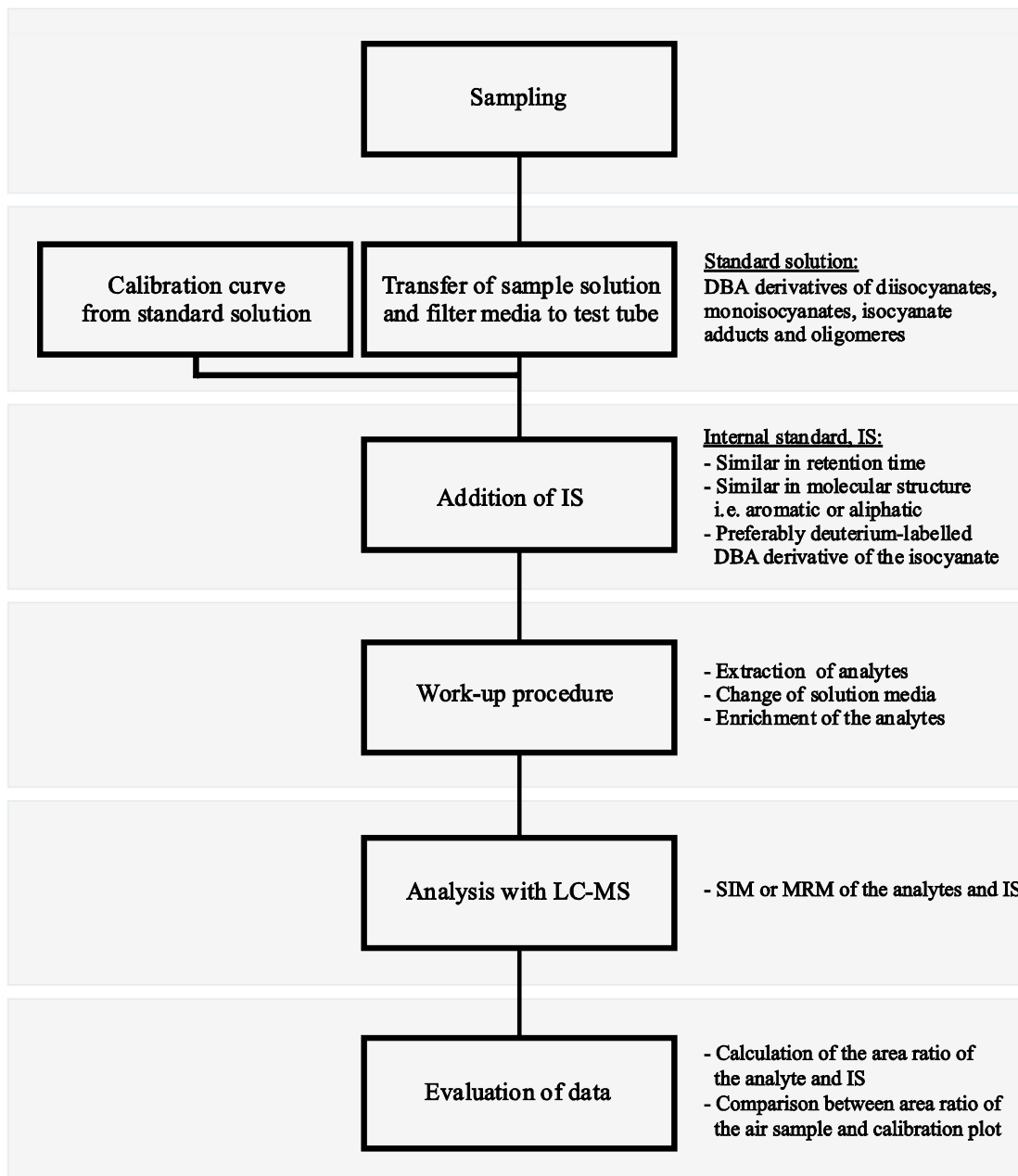

Figure 1 — Principle of the described method

4 Reagents and materials

4.1 DBA reagent.

Analytical grade di-*n*-butylamine is commercially available.

4.2 Solvents.

ICS 13.040.30

Price based on 29 pages

The reagent solvent, typically toluene, and other solvents, such as acetonitrile, isooctane, and methanol, should be of liquid chromatographic quality.

4.3 Formic acid, concentrated formic acid, analytical grade.

4.4 Acetic acid, concentrated acetic acid, analytical grade.

4.5 Sulfuric acid 5 mM, 0,27 ml of concentrated sulfuric acid (98 %) is added to 1 000 ml of water.

4.6 Reagent solution.

In a 1 l volumetric flask, dilute 1,69 ml of DBA in toluene and make up to the mark. The solution is stable and no special care during storage is necessary.

4.7 Reagent solution, for solvent-free sampler.

4.7.1 Solution 1: 0,74 mol·l⁻¹ DBA.

Mix 80 ml methanol and 12,5 ml DBA in a 100 ml volumetric flask. Then while stirring, slowly add 4,16 ml of acetic acid to the flask. Finally, add methanol to the flask, and make up to the mark.

4.7.2 Solution 2: 1,5 mol·l⁻¹ DBA.

Mix 60 ml methanol and 25 ml DBA in a 100 ml volumetric flask. Then while stirring, slowly add 8,32 ml of acetic acid to the flask. Finally, add methanol to the flask, and make up to the mark.

4.8 HPLC mobile phases.

4.8.1 LC-MS.

The weak mobile phase (mobile phase A) consists of water/acetonitrile (95/5 volume fraction) and 0,05 % formic acid. The strong mobile phase (mobile phase B) consists of water/acetonitrile (5/95 volume fraction) and 0,05 % formic acid. The mobile phases are degassed prior to use.

4.8.2 LC-CLND.

The weak mobile phase (mobile phase C) consists of water/methanol (95/5 volume fraction) and 0,05 % formic acid. The strong mobile phase (mobile phase D) consists of water/methanol (5/95 volume fraction) and 0,05 % formic acid. The mobile phases are degassed prior to use.

5 Preparation of standard solutions

5.1 Reference compounds

Reference compounds are necessary for LC-MS determination of isocyanate derivatives. For the commercially available isocyanates, the DBA derivatives are easily prepared by direct derivatization with DBA. DBA derivatives for the isocyanates not commercially available can be made from the bulk material or from the thermal decomposition of PUR or urea-based resins used at the work place. Alternatively, standard solutions can be purchased (see Annex C).

Error! Reference source not found.

5.2 Di-*n*-butylamine (DBA) derivatives of isocyanates

5.2.1 Preparation of isocyanate-DBA derivatives of commercially available isocyanates

Many frequently used isocyanates are commercially available from companies supplying laboratory chemicals such as HDI, 2,4-TDI and 2,6-TDI, 4,4'-MDI, 4,4'-HMDI, 1,5-NDI, IPDI, Phi, MIC, EIC, PIC, and BIC. The purity of the isocyanates varies, and some contain isomers.

Calibration standards are made by spiking accurately weighed amounts or volumes (ca 0,1 mmol) of isocyanates in 100 ml of isooctane. A 1 ml volume is added to 100 ml of toluene containing 0,01 mol·l⁻¹ of DBA (ca 0,01 μmol·ml⁻¹ of the DBA derivative).

The procedure for the synthesis of derivatives is as follows:

- 1) Dilute 6 mmol of isocyanate in 2 ml of isooctane.
- 2) Dissolve 60 mmol of DBA in 20 ml of isooctane.
- 3) Add the isocyanate solution to the DBA solution dropwise under continuous stirring.
- 4) Evaporate the reaction mixture to dryness in a rotating evaporator.
- 5) Dry the residue under vacuum to remove excess DBA.

It is also possible to prepare the isocyanate-DBA derivatives by collecting the thermal degradation products of the corresponding carbamate esters in an impinger flask containing a DBA solution (as specified in 5.2.3.3).

5.2.2 Preparation of ICA and MIC-DBA

When urea is thermally degraded, ICA is formed.

Heat an amount of urea (20 mg) to about 300 °C in a glass tube. Collect the degradation products in an impinger flask containing DBA in toluene (0,5 mol·l⁻¹). Wash the toluene solution containing the ICA-DBA derivatives with water, whereupon the organic phase is evaporated in a vacuum centrifuge and the residue is dissolved in methanol. Characterize the solution, as described in 5.2.4.

The same procedure can be applied for preparation of MIC-DBA derivatives, by collecting thermal degradation products of 1,3-dimethyl urea.

5.2.3 Preparation of deuterium-labelled isocyanate-DBA derivatives

5.2.3.1 Internal standards

For accurate LC-MS quantifications, it is important to use proper internal standards, not only to compensate for variations during the work-up procedure, but also to compensate for fluctuation in the MS instrument response. Ideally, each analyte should have its own deuterium-labelled analogue. For isocyanate-DBA determinations, it is possible to use DBA derivatives of deuterium-labelled isocyanates or d₉- and d₁₈-DBA derivatives of the isocyanates as internal standards.

ICS 13.040.30

Price based on 29 pages

Error! Reference source not found.

The quality of the quantification is influenced by the number of deuterium substitutions in the internal standard (less deuterium in the molecule result in higher precision). Having the deuterium on the isocyanate, and not on the DBA, has advantages when performing structural identification using MS and MS/MS. It is then possible to distinguish between labelled and non-labelled fragments that originate from the isocyanate itself. Therefore, the ideal internal standards are the DBA derivatives of the deuterium-labelled isocyanates. However, they are labour intensive to prepare, and they are only available for a few isocyanates.

The deuterium-labelled d_9 - and d_{18} -DBA derivatives are easy to prepare, and any technical isocyanate or thermal degradation product can be derivatized and used as internal standard.

5.2.3.2 DBA derivatives of deuterium-labelled isocyanates

Dissolve a 10 mmol aliquot of the deuterium-labelled corresponding amine in 20 ml of toluene. Thereafter, add 150 μ l pyridine and 40 ml of 5 mol·l⁻¹ NaOH. Then add 1,5 ml of ethyl chloroformate dropwise under continuous stirring. After 10 min, the toluene phase is separated, and the solvent is evaporated.

Place the residue containing the formed amine carbamate ester (10 μ l) in a glass tube. Heat the tube to about 300 °C. By connecting the tube to an impinger flask, containing 0,5 mol·l⁻¹ DBA in toluene, the formed deuterium-labelled isocyanate is collected as a DBA derivative. Evaporate the solvent, and dissolve the residue in methanol to an appropriate concentration. Characterize the solution, as described in 5.2.4.

5.2.3.3 d_9 -DBA and d_{18} -DBA derivatives of the isocyanates

Prepare the deuterium-labelled d_9 - and d_{18} -DBA derivatives by dissolving accurately weighed amounts of the isocyanates in 10 ml of 0,1 mol·l⁻¹ d_9 -DBA or d_{18} -DBA in toluene.

Prepare the deuterium-labelled derivatives of ICA and MIC by placing 20 mg of urea for ICA and 1,3-dimethyl urea for MIC in a glass tube. Heat the tube to about 300 °C and collect the formed ICA and MIC in impinger flasks containing 0,1 mol·l⁻¹ d_9 -DBA or d_{18} -DBA in toluene. Evaporate the solutions containing the isocyanate d_9 -DBA or d_{18} -DBA derivatives to dryness, and dissolve the residues in methanol. Characterize the solution, as described in 5.2.4.

5.2.4 Characterization

The solutions are diluted in methanol to appropriate concentrations and characterized on the LC-MS and quantified on the LC-CLND. This technique is nitrogen specific and any nitrogen-containing compound can be used as external standard, e.g. caffeine. The technique is used in several applications.^{[13][14][15]} Quantification of volatile isocyanate-DBA derivatives can also be made by using GC-TSD.

5.3 DBA derivatives of bulk isocyanates

5.3.1 Preparation

Technical isocyanates used in industry are typically available in mixtures such as oligomers in polymeric MDI, biuret-, isocyanurate-, and allophanate-adducts, and prepolymeric forms of isocyanates. These isocyanates are typically multifunctional.

If product data sheets are available and correct, standard solutions for the technical-grade isocyanates can be prepared in the same way as described in 5.2.1, by adding a known amount of bulk isocyanate to

Error! Reference source not found.

a toluene solution of DBA. If data regarding the composition and concentrations of different isocyanates are of poor quality or missing, the bulk material shall be characterized.

The procedure for the technical-grade isocyanate is as follows:

- 1) Add an aliquot of 10 mg of the isocyanate product to a 10 ml vial containing $0,5 \text{ mol}\cdot\text{l}^{-1}$ DBA.
- 2) Sonicate the solution and evaporate it to dryness and then dissolve it in methanol.
- 3) Further dilute the solution with methanol to appropriate concentrations.
- 4) Characterize the solution, as described in 5.3.2.

5.3.2 Characterization

If the isocyanates that are present in the bulk are known or reference compounds are available, calibration standards can be prepared, as described in 5.2.1.

If the isocyanates that are present in the bulk are unknown, qualitative data are obtained with full-scan chromatograms for DBA-derivatized bulk material. The obtained structural data together with the LC-CLND data make it possible to calculate the concentrations of the different components in the solution. The characterized bulk sample solution is used as a calibration standard for LC-MS.

When prepolymeric forms or complex isocyanates are to be determined, it can be difficult to quantify each individual isocyanate using LC-MS. However, one or more components can be used as index compounds. The total isocyanate group (NCO) concentration of the bulk is obtained by titration with DBA (see Reference [16]) and standard solutions can be prepared (dilution). The concentration of isocyanates in the air sample is estimated by comparison of peak areas. This can be performed with the assumption that the composition of the bulk material reflects the composition of the airborne isocyanates. The obtained result gives the concentration of the total isocyanate content in the air. However, detection limits are increased by the factor of the ratio of the total isocyanate concentration and the assumed concentration of the index isocyanate. Still, in most cases, levels below 1/10 of the threshold limit value (TLV) are possible to determine.

5.4 DBA derivatives of isocyanates in thermal decomposition products of polyurethane (PUR) or urea-based resins

5.4.1 Preparation

During the thermal decomposition of PUR or urea-based resins, isocyanates that are not commercially available are formed. PUR or urea-based materials can be thermally decomposed at appropriate temperatures. The emitted degradation products are collected in impinger flasks (filters in series) containing $0,5 \text{ mol}\cdot\text{l}^{-1}$ DBA. The solutions are evaporated to dryness, and the residues are dissolved in methanol.

5.4.2 Characterization

Qualitative data are obtained with LC-MS. The obtained structural data together with the LC-CLND data make it possible to calculate the concentrations of different components in the solution. The characterized and diluted sample solution is used as a calibration standard for LC-MS.

ICS 13.040.30

Price based on 29 pages

Error! Reference source not found.

5.5 Stability

Solutions of isocyanate-DBA derivatives (MDI, 2,4- and 2,6-TDI, HDI, IPDI, PhI, BIC, PIC, EIC, MIC, and ICA) have been found stable in toluene, acetonitrile, and methanol for 6 mo when stored at 8 °C. NDI-DBA has limited stability and shall be freshly prepared and quantified before use as a calibration standard.

6 Apparatus

6.1. Sampler, can be either an impinger (6.1.3) followed by a filter (6.1.1) connected in series to the sampling pump (6.1.5) through a vapour trap (6.1.7) or a solvent-free sampler (6.1.4) connected to the sampling pump (6.1.5).

6.1.1 Filter.

Use a 13 mm glass fibre filter (binder free) with a pore size of 0,3 µm.

6.1.2 Filter holder.

Use a 13 mm polypropylene filter holder with luer-lock connections.

6.1.3 Midget impingers.

A midget impinger consists of a tapered inlet tube. Match the two parts so that the distance between the inlet and the receiver bottom is 1 mm to 2 mm. The filter holder is attached to the outlet of the impinger, by using an impinger with a luer-lock fitting on the outlet. Alternatively, the filter holder is attached to the outlet of the impinger by flexible tubing.

6.1.4 Solvent-free sampler.

Cut three kinds of glass fibre filters from a glass fibre filter sheet (binder free) with a pore size of 0,3 µm:

- 1) rectangular filter, 2,5 cm × 5,7 cm;
- 2) rectangular filter, 1,4 cm × 5,7 cm;
- 3) round filter, 13 mm diameter.

To prepare the sampler, the different filters are mounted in the tube and the filter holder unimpregnated. The inside of the tube is lined with filter 1 (2,5 cm × 5,7 cm), so that it covers the inner walls of the tube. Filter 2 (1,4 cm × 5,7 cm) is folded as a "V" and also placed inside the tube to increase the collection efficiency, by increasing the number of channels in the tube.

The dry sampler is then impregnated by dropwise adding 1,5 ml 1,4 M DBA-acetic acid in methanol to the filters at the top of the tube. After impregnation, the tube is dried by blowing nitrogen through the tube for evaporation of methanol.

The round-end filters (diameter of 13 mm) are impregnated by adding 100 µl 0,7 M DBA-acetic acid solution, and dried under nitrogen in open cassettes. When solvent evaporation is complete, the end filters are mounted on the denuder. Then the complete sampler is sealed at both ends. Impregnation and drying of the filters are performed in a container filled with nitrogen to avoid contamination.

Error! Reference source not found.

Alternatively, the sampler can be purchased (see Annex C).

Dimensions in millimetres

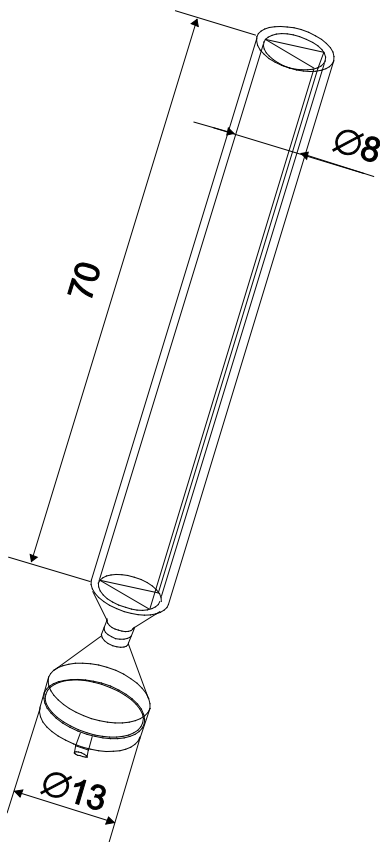

Figure 2 — Solvent-free sampler

6.1.5 Sampling pump, complying to the requirements of ISO 13137, capable of maintaining the flow rate at $1 \text{ l}\cdot\text{min}^{-1}$ for impinger-filter sampling and $0,2 \text{ l}\cdot\text{min}^{-1}$ to $0,8 \text{ l}\cdot\text{min}^{-1}$ for solvent-free sampling during the sampling time.

6.1.6 Tubing.

Use rubber tubing of suitable length and of appropriate diameter to ensure a leak-proof fit to both the pump and the sampler outlet.

6.1.7 Vapour trap.

Use a vapour trap (with an internal diameter of 17 mm and a length of 140 mm) filled with charcoal (with a median particle size $<3 \text{ mm}$) between the impinger filter and the sampling pump. This is for the protection of the pump from toluene vapour. The charcoal in the vapour trap needs to be frequently replaced and recycled, depending on sampling time.

ICS 13.040.30

Price based on 29 pages

Error! Reference source not found.

6.2 Flow meter.

Use a portable flow meter capable of measuring the appropriate flow rate with an acceptable accuracy.

6.3 Liquid chromatographic system.

In this method, a micro-LC system is used in order to improve the sensitivity, to minimize the maintenance on the MS, and to minimize the consumption of the mobile phase. The micro-LC system is described in the following paragraphs. If desired, this system can be replaced by a conventional LC system.

6.3.1 Autosampler.

6.3.1.1 LC-MS.

On-column focusing is performed by partially filled loops (typically 10 μl total volume) of 2 μl loop injections between 4+4 μl of 50/20/30 water/methanol/acetonitrile. Any commercially available autosampler capable of making partially filled loop injections and making sample injections of acceptable accuracy and precision can be used.

6.3.1.2 LC-CLND.

On-column focusing is performed by partially filled loops (typically 10 μl total volume) of 2 μl loop injections between 4+4 μl of 50/50 methanol/water. Any commercially available autosampler capable of making partially filled loop injections and making sample injections of acceptable accuracy and precision can be used.

6.3.2 Pumping system (LC-MS and LC-CLND).

An HPLC pump capable of gradient elution with a flow rate of 100 $\mu\text{l}\cdot\text{min}^{-1}$ is required.

6.3.3 Analytical column (LC-MS and LC-CLND).

An HPLC column capable of separating the different isocyanate derivatives is required.

EXAMPLE An example of a suitable column is a PepMap[®] C₁₈¹) (50 mm \times 1,0 mm with 3 μm particles).

6.3.4 Tubing.

Use short (<40 cm) tubing with a small internal diameter (typically ID <0,1 mm).

6.3.5 Detectors.

6.3.5.1 LC-MS.

Any modern MS equipped with a robust and stable electrospray interface will have the necessary performance. MS detection is performed with atmospheric pressure ionization, monitoring the positive ions. For quantification, the selected ions are monitored. Full spectra are obtained using continuous scans (typically 50 amu to 1 500 amu) for identification of unknown isocyanates. If desired, a UV

¹ PepMap[®] is an example of a suitable product available commercially. This information is given for the convenience of users of this part of ISO 17734 and does not constitute an endorsement by ISO of this product.

Error! Reference source not found.

detector can be used in series, prior to the MS. The UV detector needs to be equipped with a micro flow cell (typically 300 nl) to minimize peak band broadening.

6.3.5.2 LC-CLND.

Use a detector which is specific for bound nitrogen.

6.4 Ultrasonic bath.

Sonication of samples is necessary to make sure that isocyanate-DBA derivatives are dissolved in the extraction solution and that the sample remaining after evaporation is properly dissolved in the added solvent.

6.5 Evaporator.

Equipment for the evaporation of the sample solvent is necessary, preferably a vacuum centrifuge. A gentle evaporation procedure is desirable since there is a risk that a tough evaporation can result in losses of the most volatile isocyanate-DBA derivatives.

6.6 Glassware, glass beakers, and volumetric flasks (Volumetric flasks should conform to ISO 1042).

7 Air sampling

7.1 Pre-sampling laboratory preparation

7.1.1 Cleaning of the sampling equipment

Impingers should be taken apart and soaked in an alkaline cleaning solution for a minimum of 2 h. The upper part shall be rinsed with an alkaline cleaning solution, pure water, and finally deionized water. If the nozzle is clogged, place it in an ultrasonic bath, and then continue with the cleaning procedure. The lower part should be cleaned in a laboratory dishwasher. Both parts should be dried in an oven.

The filter cassettes and the gaskets should be immersed in ethanol in a glass beaker, sonicated for at least 15 min, rinsed with deionized water, and dried in an oven.

7.1.2 Preparation of the reagent solution and extraction solution tubes

Prepare test tubes containing 10 ml of 0,01 mol·l⁻¹ DBA as the reagent solution for the impingers. If the gas phase and the particulate phase are to be collected separately, prepare test tubes containing 10 ml of 0,01 mol·l⁻¹ DBA as the extraction solution tubes for the filters.

7.2 Pre-sampling field preparations

Assemble the sampling system with the filter cassette containing the glass fibre filter coupled to the outlet of the impinger. Transfer the reagent solution to the impinger.

Calibrate the pumps with the impinger-filter sampling system in line, using a portable flow meter. Fill the impinger with the appropriate amount of reagent solution during calibration. The sampling rate should be 1 l·min⁻¹.

ICS 13.040.30

Price based on 29 pages

Error! Reference source not found.

7.3 Collection of air samples

7.3.1 Measurement task

In order to relate measurement results to occupational exposure limit values, take samples in the workers' breathing zone. In order to illustrate risks of being exposed, take stationary samples at every place at the work-site where isocyanates can be emitted into the air and workers are potentially exposed. It is also important to include operations that are not frequently performed, for example repair and maintenance. Differences in materials and batch-to-batch variations are factors that also should be taken into account when sampling. Collect a sufficient number of samples in order to make a representative exposure assessment.

Stationary sampling can be collected as background samples or samples reflecting the worst-case emission source. Background samples are normally collected at head height, taking into account the head height of the workers' position while carrying out the work tasks. Samples to detect emission sources or worst-case scenarios are often collected close to the process and not necessarily representative for workers' exposure but for identification of "hot spots" where substances in the process are emitted.

7.3.2 Impinger-filter sampling

Position the sampling system, either attached to the worker with the inlet in the breathing zone for personal samples, or stationary for area samples. Connect the pump to the sampling system, and place a charcoal vapour trap in line between the pump and the sampling system in order to protect the pump from the solvent vapour. Make sure that the equipment does not disturb the work operation, and that the impinger can be held in a vertical position during the whole sampling period.

When ready to begin sampling, switch on the pump. Record the time of sampling. At the end of the sampling period, measure the flow rate. Rinse the impinger with $0,01 \text{ mol}\cdot\text{l}^{-1}$ DBA in toluene. Transfer the rinsing solution together with the impinger solution to a test tube, and immerse the glass fibre filter into either the sampling solution or an extraction solution tube using tweezers. If the filter is transferred to an extraction solution, it is possible to determine the amount of isocyanates in the particulate phase that passes through the impinger (i.e. particles approximately $0,01 \mu\text{m}$ to $1,5 \mu\text{m}$), separately from the gas phase and large particles ($>1,5 \mu\text{m}$) sampled in the impinger.

For an illustration of the sampling procedure, see Figure 3. Calculate the volume drawn through the sampler from the sampling time and the average sampling flow. The total sampling time is limited (about 30 min), unless the reagent solution is refilled during sampling.

If sampling is performed for more than 30 min or at temperatures above $25 \text{ }^\circ\text{C}$, care should be taken that the sampling solution is not evaporated. If so, the sampling solution needs to be refilled. Sufficient $0,01 \text{ M}$ DBA in toluene is added to the impinger bottle.

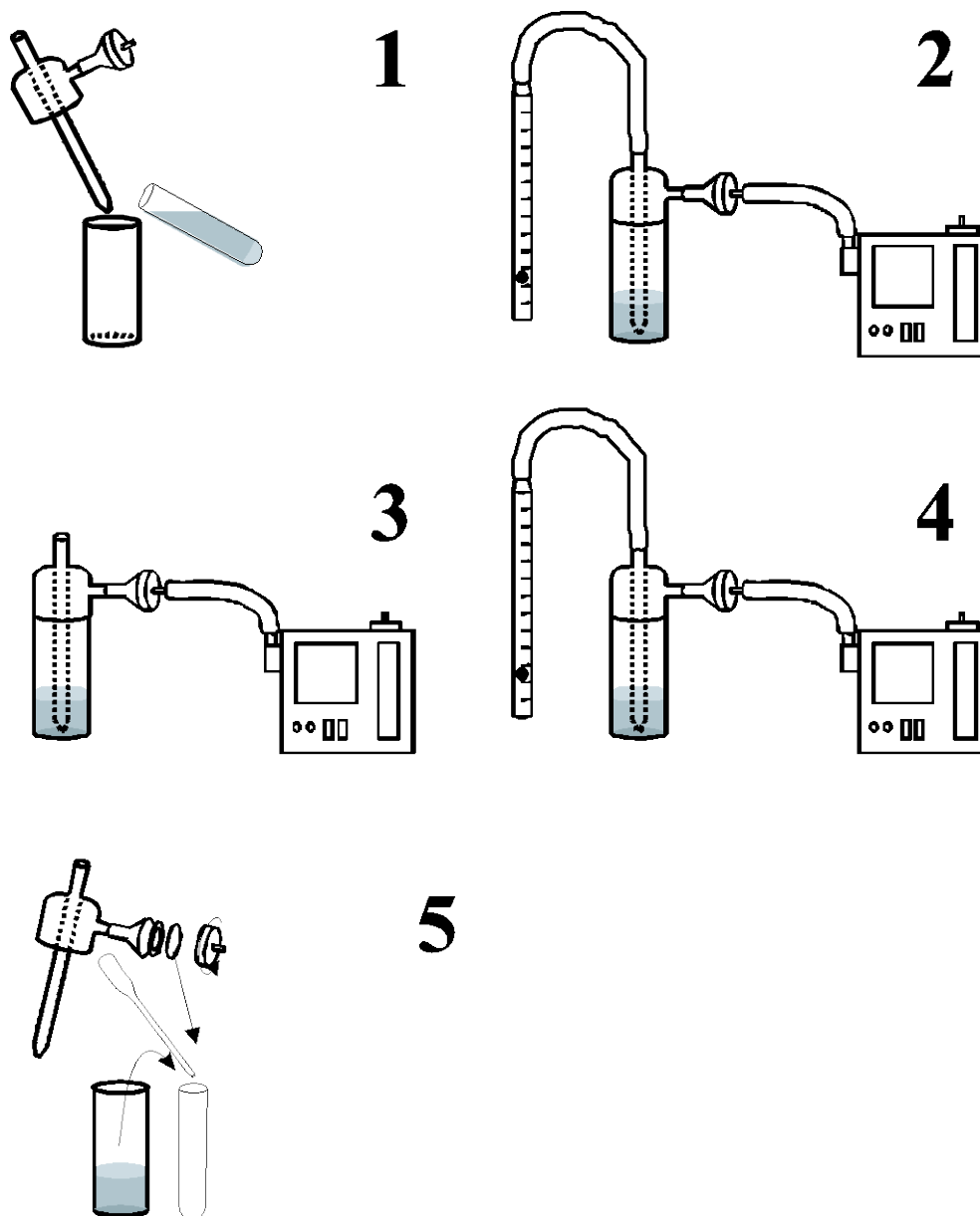

Key

- 1 The impinger solution is transferred to the impinger flask.
- 2 The airflow is measured and the sampling pump is calibrated to 1 l/min.
- 3 Air sampling
- 4 The airflow is measured.
- 5 The impinger solution and the rinsing solution are transferred to a test tube. The filter is either transferred to the impinger solution tube or to an extraction solution tube.

Figure 3 — Illustration of the sampling procedure

7.3.3 Solvent-free sampling

Take off the plugs in both ends just prior to the air sampling. Connect an air sampling pump to the filter-holder outlet with a charcoal vapour trap between the sampler and the pump. Perform the air sampling

ICS 13.040.30

Price based on 29 pages

with an airflow in the range of 0,2 l·min⁻¹ to 0,8 l·m⁻¹ and check the flow rate before and after sampling. After sampling, disconnect the sampler from the pump, and plug both ends with polypropylene plugs. No field extraction is necessary. Prolonged sampling (>8 h) can be performed without any loss of sampling performance.

7.3.4 Post-sampling field preparations

Pumps are calibrated before and after sampling so as to compute the mean flow (12.3.2.1).

7.4 Blanks

From every series of samples, there should be an appropriate number, e.g. 3, of field blanks and lab blanks ($n = 3$). Field blanks are samples that have been handled exactly like the other samples out in the field, except that no air has been drawn through. Lab blanks will be useful to identify if there is contamination, if it took place in the lab or in the field.

7.5 Raw material

From each work-site, it is desirable to collect samples of the raw material suspected of emitting isocyanates during the work operation. If the material is a bulk isocyanate product, it could be useful for qualitative identification of isocyanate species in the air samples. These products are also applicable for the preparation of the reference solutions for the quantification of unknown isocyanates (see 5.2 and 5.3).

Collecting and subsequent laboratory testing of materials that are known or are suspected of emitting isocyanates is useful for assessing the exposure. The testing can consist of extraction, heating, or other processing of the material, as similar to the original work operation as possible.

7.6 Shipment of samples

The test tubes containing the DBA-toluene samples should be shipped in individual plastic cases and preferably kept in an upright position. The sampling solution tubes should be placed well apart from any raw material collected. Regulations for shipping hazardous (dangerous) materials should be followed as appropriate.

8 Laboratory sample preparation

8.1 Sample sequence

In each sample sequence, a number of samples consist of field blanks, lab blanks, chemical blanks, internal standard blanks, and an appropriate number of calibration standards. Internal standard blanks are reagent solutions from the same batch as the reagent solution used for air sampling spiked with internal standard in the work-up procedure. Chemical blanks are pure toluene with no addition of internal standard in the work-up procedure.

8.2 Work-up procedure

8.2.1 General

For the preparation of the calibration standards, aliquots of 10 ml toluene solutions, containing 0,01 mol·l⁻¹ DBA, are spiked with the isocyanate-DBA derivatives to concentrations appropriate for the

Error! Reference source not found.

calibration curve (typically five to seven calibration standards in the range of 0 µg/sample to 0,5 µg/sample).

Upon receiving the air samples from the field, add internal standards (deuterium-labelled isocyanate derivatives) to the air samples, to the standard solutions, to the field blanks, and to the internal standard blanks. Place the samples in an ultrasonic bath for 15 min. If the solutions contain filters, place the samples in a centrifuge for 10 min (3 000 r/min). Remove the sample solutions from the filters with a pipette into new test tubes. Evaporate the solvent from the samples and the standards. Dissolve the residues in 0,5 ml acetonitrile and place them in an ultrasonic bath for 15 min.

8.2.2 Solvent-free sampling

To extract the isocyanate-DBA derivatives from the glass fibre filters, a double extraction to an organic solvent is performed. The filters are carefully removed from the denuder and end filter using tweezers. The filters are then folded and placed in screw-cap test tubes. To the filter, 3 ml 5 mM H₂SO₄, 3 ml methanol, and 6 ml toluene are added. An internal standard solution, containing deuterium-labelled isocyanate-DBA derivatives, is also added. Prepare the calibration standards in test tubes containing the same extraction solutions and internal standards as the extracted air samples. The filter is then shaken for 5 min, sonicated for 10 min in an ultrasonic bath, and then shaken again for 20 min. After centrifugation for 10 min at 3 000 r/min, the toluene solution is separated to a new test tube. To the tube containing the filter and mixture of methanol and acid, another aliquot of 6 ml toluene is added, and the extraction procedure is repeated. The toluene is separated to the same test tube as the first, giving a toluene solution with a total volume of about 12 ml. Remove the solvent and the excess reagent from the samples by evaporation. Dissolve the residues in 0,5 ml acetonitrile and place them in an ultrasonic bath for 15 min.

9 Instrumental settings

9.1 HPLC program (LC-MS)

For simultaneous determination of the DBA derivatives of monoisocyanates and diisocyanates, the following mobile phase composition can be used:

- flow rate: 100 µl·min⁻¹;
- 0 min to 15 min: linear gradient from 50 % mobile phase B to 90 % mobile phase B;
- 15 min to 20 min: re-equilibrate at 50 % mobile phase B.

If a single or a few derivatives are to be determined, isocratic elution or gradient elution with appropriate mobile phase composition can be performed.

If high molecular weight DBA derivatives (e.g. prepolymers, isocyanate adducts) are to be determined together with DBA monomers, it is necessary to continue with the gradient up to 100 % B and maintain at 100 % B until all analytes are eluted.

ICS 13.040.30

Price based on 29 pages

Error! Reference source not found.

9.2 HPLC program [LC-chemiluminescent nitrogen detector (LC-CLND)]

For quantifying DBA derivatives in reference solutions prepared in-lab, generally at higher concentrations, the following mobile phase composition can be used:

- flow rate: 100 $\mu\text{l}\cdot\text{min}^{-1}$;
- 0 min to 15 min: linear gradient from 40 % mobile phase D to 100 % mobile phase D;
- 15 min to 30 min: 100 % mobile phase D;
- 30 min to 35 min: re-equilibrate at 40 % mobile phase D.

Depending on the properties of the analytes in the sample, stronger, weaker, or isocratic elution can be used.

9.3 Mass spectrometer

Settings of the MS depend greatly on the type of instrument that is used. Optimization is normally performed by the introduction of flow at 100 $\mu\text{l}\cdot\text{min}^{-1}$ of mobile phase containing low and high mass aromatic and aliphatic isocyanate derivatives. Optimal settings vary for the analytes and the ions to be monitored. Practical settings are not the optimum for all of the compounds to be studied.

For quantification, selected ions are monitored, e.g. the molecular ion $[\text{MH}]^+$, but other typical ions can be used, such as $[(\text{DBA})\text{H}]^+$ ($m/z = 130$), $[(\text{DBA})\text{CO}]^+$ ($m/z = 156$), $[\text{MH}-129]^+$, and $[\text{MNa}]^+$ (see Annex B.4).

For LC-MS/MS quantifications, multiple reaction monitoring is performed by monitoring the daughter ion, $[(\text{DBA})\text{H}]^+$, $[(\text{DBA})\text{CO}]^+$, or $[\text{MH}-129]^+$, from the protonated molecular ion $[\text{MH}]^+$.

For identification of unknown isocyanates, full spectra are obtained using continuous scans (typically 50 amu to 1 500 amu).

10 Data handling

10.1 Identification

For identification, the retention times of sample peaks in the selected ion chromatograms are compared to the standards and the internal standards.

10.2 Calibration curves

The peak areas of the isocyanate-DBA derivative and the internal standard are measured, and the ratio is calculated. The ratio versus the concentration is plotted. A coefficient of correlation $>0,98$ can be achieved. Values below 0,98 will increase the uncertainty, as calculated in 12.2. Examples of calibration data can be found in References [5-12].

Quadratic fit of the calibration curves can sometimes be necessary, usually because of a large dynamic range. Type and condition of used instrumentation can affect the linearity of the calibration. Quadratic calibration curves could be tolerated to some extent. However, care should be taken when using a quadratic fit so that the performance of the method is not affected.

Error! Reference source not found.

10.3 Quantification

Quantification is accomplished by comparing the area ratio of the sample peak and internal standard to the calibration plot.

11 Interferences

The reactions between aromatic and aliphatic isocyanates with DBA in the presence of some possibly interfering compounds (water, morpholine, phenol, ethanol, TDA, MDA, HDA, and IPDA) have been investigated.^{[4][5]} No losses of the studied isocyanates were observed.

12 Determination of performance characteristics

12.1 General

The measurement of the concentration of isocyanates in workplace air has associated with it an uncertainty that can be expressed as combined uncertainty (see Reference [17]) or expanded uncertainty (see Reference [18]). Thus, an uncertainty assessment has to be performed according to one or other of these definitions of uncertainty. In both cases, this consists of the determination of uncertainty contributions evaluated by means of laboratory and simulated field tests or from existing information. The values obtained of the measurement uncertainty can then be compared with pre-set criteria, for example those in Reference [17] or those defined in national or international legislation.

12.2 Relevant uncertainty contributions and criteria

Uncertainty contribution	Quantity	Subclause	Criterion
<i>Sample volume</i>	V_{sam}	12.3.2	
Sample flow – calibration	q_{cal}		Relative uncertainty <2 %
Sample flow – variation	Δq		<5 %
Sampling time	t		Relative uncertainty <0,1 %
Temperature during sampling	T		Relative uncertainty <4 %
Pressure during sampling	p		Relative uncertainty <2 %
<i>Analyte mass</i>	m_{sam}	12.3.3	
Analyte stability during storage	k_{AS}		No significant difference between results of analysis of samples before and after storage
Reaction/extraction efficiency	E_{RE}		>90 % at the limit value with a relative uncertainty <3 %
Mass of isocyanate in calibration standards	m_{CS}		Relative uncertainty <2 %
Calibration lack-of-fit	LOF		Relative residuals over the calibration range <3 %; at the limit value <2 %
Response drift between calibrations	D_R		<3 %

ICS 13.040.30

Price based on 29 pages

Error! Reference source not found.

Analytical precision	r		<1 %
Selectivity	s		Resolution factor >1
Blank level	m_{BL}	12.3.4	<50 ng with a relative uncertainty <5 %
Between-laboratory variations	bl	12.3.5	Relative uncertainty <7,5 %

12.3 Assessment of performance characteristics (following the detailed approach in Reference [18])

12.3.1 Collection efficiency — relative to particle size distribution

For a complete description of the performance requirements and tests to be performed, see Reference [18].

12.3.2 Air sampling

12.3.2.1 Sampling volume

The sampled volume of air is calculated on the basis of measuring the sample flow rate before and after sampling, as specified in ISO 16200-1, using Formula (1).

$$V_{\text{sam}} = \frac{(q_{\text{start}} + q_{\text{end}})}{2} \cdot t \quad (1)$$

where

V_{sam} is the sampled volume of air (usually in millilitres);

q_{start} is the sample flow rate at the beginning of the sampling period (usually in millilitres per minute);

q_{end} is the sample flow rate at the end of the sampling period;

t is the sampling time (in minutes).

The uncertainty in the volume of air sampled is built up of contributions from

- the measurements of the flow rates before and after sampling,
- the measurement of the sampling time, and
- the variations in the flow rate during the sampling period.

It can be expressed using Formula (2).

$$\frac{u^2(V_{\text{sam}})}{V_{\text{sam}}^2} = \frac{u^2(q_{\text{start}}) + u^2(q_{\text{end}})}{(q_{\text{start}} + q_{\text{end}})^2} + \frac{u_t^2}{t^2} + \frac{u_{\text{var},q}^2}{\left[\frac{(q_{\text{start}} + q_{\text{end}})}{2}\right]^2} \quad (2)$$

where the last term represents the uncertainty contribution due to flow rate variations during sampling.

Error! Reference source not found.

12.3.2.2 Sampling time

The sampling time, t , can be measured to within $\pm 0,5$ min. For a sampling time of 8 h, the relative uncertainty due to the measurement of t is about 0,1 % and is negligible.

12.3.2.3 Variations in flow rate during sampling

The flow rate during sampling is unknown. The uncertainty due to the variations in the flow rate during sampling can be estimated by assuming a uniform distribution using Formula (3).

$$u_{\text{var},q}^2 = \frac{(q_{\text{start}} - q_{\text{end}})^2}{12} \quad (3)$$

12.3.2.4 Conversion of sample volume to STP

For the conversion of concentrations to STP, knowledge is required of the actual mean temperature and pressure during sampling. Uncertainties in values of T and p used for conversion can be obtained from:

- actual measurements, taking into account the uncertainty in the calibration of temperature and pressure sensors used, using Formula (4):

$$u^2 = u_{\text{cal}}^2 + \frac{s_{\text{meas}}^2}{n} \quad (4)$$

where

u_{cal} is the uncertainty due to calibration of the sensor;

s_{meas} is the standard deviation of the temperature/pressure measurements;

n is the number of temperature/pressure measurements;

- knowledge of extremes of temperature and pressure during sampling, assuming these to be uniformly distributed.

For example, if the temperature extremes are known to be T_{min} and T_{max} , the uncertainty in T can be calculated using Formula (5).

$$u_T^2 = u_{\text{cal}}^2 + \frac{(T_{\text{max}} - T_{\text{min}})^2}{12} \quad (5)$$

Generally, the first term will be negligible compared to the second.

12.3.2.5 Combined uncertainty of sample volume

The above uncertainty contributions are combined to give the uncertainty in the sample volume converted to SPT using Formula (6).

$$\frac{u^2(V_{\text{sam, SPT}})}{V_{\text{sam, SPT}}^2} = \frac{u^2(V_{\text{sam}})}{V_{\text{sam}}^2} + \frac{u^2(T)}{\bar{T}^2} + \frac{u^2(p)}{\bar{p}^2} \quad (6)$$

ICS 13.040.30

Price based on 29 pages

Error! Reference source not found.

where

\bar{T} is the mean temperature during sampling;

\bar{p} is the mean pressure during sampling.

12.3.3 Analysis

12.3.3.1 Sampled mass

The mass of isocyanate in the air samples can be expressed using Formula (7).

$$m_{\text{sam}} = \frac{m_{\text{anal}}}{E_{\text{coll}} \cdot \Delta S \cdot k_{\text{AS}} \cdot E_{\text{RE}}} \quad (7)$$

where

E_{coll} is the collection efficiency;

ΔS is the sampler variability;

k_{AS} is the analyte stability in the sample;

E_{RE} is the reaction/extraction efficiency;

m_{anal} is the uncorrected analytical mass of isocyanate in the analytical sample.

12.3.3.2 Analyte stability

The analyte stability shall be experimentally established for storage under conditions (time, temperature, environment) typical to the individual laboratory. Tests shall be performed at an isocyanate level corresponding to a concentration equivalent to the limit value.

At time $t = 0$ and time t , each sample shall be analysed under repeatability conditions ($n = 6$). For both times, the samples shall be randomly picked from a batch of representative samples in order to minimize possible systematic concentration differences. As a test of (in)stability, a t -test will be performed (95 % confidence, two-sided). The uncertainty of the stability determination consists of contributions from

- desorption (random part of desorption efficiency),
- calibration (random part of calibration),
- analytical precision, and
- inhomogeneity of the sample batch.

As such, the contribution of the determination of k_{AS} will already be incorporated in other contributions and needs not to be taken into account.

12.3.3.3 Reaction/extraction efficiency

The reaction/extraction efficiency of isocyanate and its uncertainty are typically obtained from replicate measurements on certified reference materials (CRM) of the isocyanate or of its reaction product(s). The uncertainty due to incomplete reaction/extraction for the isocyanate level corresponding to the limit value is calculated from contributions of

Error! Reference source not found.

- the uncertainty in the concentration of the CRM,
- the standard deviation of the mean recovery, and
- the bias between the mass of isocyanate in the CRM and the mean mass of isocyanate.

It is determined using Formula (8):

$$\frac{u_{E_{RE}}^2}{E_{RE}^2} = \frac{u_{m_{CRM}}^2}{m_{CRM}^2} + \frac{s^2(\bar{m}_{DE})}{\bar{m}_{DE}^2} + \frac{(\bar{m}_{DE} - m_{CRM})^2}{m_{CRM}^2} \quad (8)$$

where

m_{CRM} is the mass of isocyanate in CRM;

$u_{m_{CRM}}$ is the uncertainty in the mass of isocyanate in CRM;

\bar{m}_{DE} is the mean mass of isocyanate determined;

$s(\bar{m}_{DE})$ is the standard deviation of the mean of the replicate measurement results.

The latter term, representing the uncertainty due to a significant bias between certified and determined mass, can be ignored if

- the bias is statistically insignificant at the 95 % level, and
- a correction is applied for the bias.

If a CRM is not available, the material with the highest metrological quality available should be used.

12.3.3.4 Uncorrected analytical mass of compound

The uncertainty in the uncorrected analytical mass of a compound is determined by

- the uncertainty in the concentrations of the calibration standards used,
- the lack-of-fit of the calibration function,
- the drift of detector response between calibrations,
- the precision of the analysis, and
- the selectivity of the chromatographic system.

12.3.3.5 Calibration standards

The uncertainty of the concentration of isocyanate in the calibration standards used depends on the type of calibration standard used.

For calibration standards consisting of solutions in toluene or acetonitrile, the uncertainty is built up of contributions from

ICS 13.040.30

Price based on 29 pages

Error! Reference source not found.

- the purity of isocyanate; this is generally known from manufacturer's specifications as a minimum purity, p :
 - $P = 99\%$, the relative uncertainty due to impurity is given by $(100-p)\%$;
 - $p \geq 99\%$, the relative uncertainty can be estimated assuming a uniform distribution using Formula (9):

$$u_{\text{pur}}^2 = \frac{(100-p)^2}{12} \quad (9)$$

- the uncertainties in the weighings of compounds and solutions, i.e. the uncertainty of the balance used.

The latter contribution is generally expressed for differential weighings using Formula (10).

$$u_{\text{weigh}}^2 = 2u_{\text{bal}}^2 \quad (10)$$

where

u_{bal} is the uncertainty of the balance used.

If this method is used for the determination of other compounds besides isocyanate, the concentration of isocyanate in the chemicals used and its uncertainty shall be established and used in the above uncertainty assessment.

12.3.3.6 Lack-of-fit of calibration function

The uncertainty due to lack-of-fit of the calibration function can be calculated for the relevant concentration (corresponding to a mass of isocyanate sampled at the limit value) from residuals of a calibration function obtained by a least-squares linear regression weighted in the concentration of isocyanate in the calibration standard using Formula (11).

$$u_{\text{LOF}}^2 = \frac{(m_{\text{regr}} - m_{\text{std}})^2}{m_{\text{std}}^2} = \rho^2 \quad (11)$$

where

m_{regr} is the mass of isocyanate calculated from the regression equation at the level of the calibration standard corresponding closest to the mass of isocyanate representing a sample at the limit value;

m_{std} is the mass of isocyanate present in the corresponding calibration standard;

ρ is the relative residual for the particular concentration level.

NOTE The lack-of-fit of the calibration function will contribute to the uncertainty due to incomplete extraction or reaction if the latter's efficiency is significantly different from 1. In that case, irrespective of whether or not a correction for incomplete reaction/extraction is applied, the uncertainty due to lack-of-fit of the calibration function needs not to be taken into account in the uncertainty assessment.

Error! Reference source not found.

12.3.3.7 Drift in detector response

The uncertainty due to response drift, D_R , can be estimated from data on the relative differences in responses between subsequent calibrations using Formula (12).

$$u_{D_R}^2 = \frac{(r_n - r_{n-1})^2}{12 \left(\frac{r_n + r_{n-1}}{2} \right)^2} \quad (12)$$

where

n is the number of replicate analyses;

r_n is the detector response for a calibration standard corresponding closest to the mass of isocyanate representing a sample at the limit value.

12.3.3.8 Precision of the analysis

The uncertainty due to the (im)precision of the analysis is determined by analysis under repeatability conditions of calibration standards of the same composition; a minimum of six replicate analyses shall be performed. The uncertainty is then calculated using Formula (13).

$$u_r^2 = \frac{s_{\text{anal}}^2}{\bar{r}^2} \quad (13)$$

where

s_{anal} is the standard deviation of the replicate responses;

\bar{r} is the mean response.

In the uncertainty assessment, this contribution is already incorporated in contributions from the determination of desorption efficiency and needs not be taken into account.

12.3.3.9 Analytical selectivity

The separation system used (liquid chromatographic column, gradient program) shall be optimized in order to minimize the uncertainty due to (unnoticed) co-elution of potential interferents.

The resolution, R , of the liquid chromatographic system used, given in Formula (14), shall be better than 1. In that case, the maximum uncertainty due to co-elution is 2,5 %. The typical uncertainty contribution will then be $\pm 0,7$ %.

$$R = \frac{\Delta t_r}{0,85(w_B + w_I)} \quad (14)$$

where

Δt_r is the difference in retention time of isocyanate and interferent (in seconds);

w_B is the peak width at half height of the peak (in seconds), with subscript B referring to

ICS 13.040.30

Price based on 29 pages

Error! Reference source not found.

isocyanate;

w_1 is the peak width at half height of the peak (in seconds), with subscript I referring to interferent.

12.3.3.10 Combined uncertainty in the analytical mass of isocyanate

The above contributions are combined to give the uncertainty of the analytical mass of isocyanate excluding the uncertainty due to imprecision using Formula (15):

$$\frac{u^2(m_{\text{anal}})}{m_{\text{anal}}^2} = \frac{u_{\text{std}}^2}{m_{\text{std}}^2} + u_{\text{LOF}}^2 + u_{\text{drift}}^2 + u_{\text{sel}}^2 \quad (15)$$

12.3.3.11 Combined uncertainty in the sampled mass of isocyanate

The contributions given in 12.3.3.4 through 12.3.3.8 and in 12.3.3.10 are combined to give the uncertainty of the mass of isocyanate in the air sample using Formula (16).

$$\frac{u^2(m_{\text{sam}})}{m_{\text{sam}}^2} = \frac{u^2(m_{\text{anal}})}{m_{\text{anal}}^2} + \frac{u_{E_{\text{RE}}}^2}{E_{\text{RE}}^2} \quad (16)$$

12.3.4 Mass of compound in sample blank

The mass of isocyanate in a sample blank is determined by analysis under repeatability conditions of a series of sample blanks; a minimum of six replicate analyses shall be performed. The uncertainty is then calculated using the slope of the calibration function extrapolated to the blank response level using Formula (17).

$$u^2(m_{\text{BL}}) = \frac{s_{\text{BL}}^2}{b_{\text{BL}}} \quad (17)$$

where

s_{BL} is the standard deviation of the replicate analytical results;

b_{BL} is the slope of the calibration function at the blank response level.

If the blank response is below 3 times the noise level of the detector at the retention time of isocyanate, then the blank level and its uncertainty shall be calculated from the detector noise level using the slope of the calibration function extrapolated to zero response assuming a uniform distribution using Formulae (18) and (19):

$$m_{\text{BL}} = \frac{3r_0}{2b_0} \quad (18)$$

$$u^2(m_{\text{BL}}) = \frac{9r_0^2}{12} \quad (19)$$

where

r_0 is the noise level;

b_0 is the slope of calibration function at zero response.

Error! Reference source not found.

12.3.5 Between-laboratory uncertainty contributions

The procedures described above are not restrictive but allow for possible variations in approaches between laboratories. The resulting additional uncertainty contributions can be quantified by performing interlaboratory comparisons involving

- the complete measurement procedure inclusive of sampling, and
- the analytical part of the measurement procedure.

Interlaboratory comparisons shall be organized, in accordance with ISO 5725-2, using samples of sufficient homogeneity to ensure that the contribution to the between-laboratory uncertainty due to inhomogeneity is negligible. In practice, an uncertainty due to inhomogeneity of <2 % will usually be sufficient.

12.3.6 Combined uncertainty

The combined uncertainty of the isocyanate concentration in the air sampled is obtained by the combination of the contributions given in Formulae (6), (14), (18), and (19) and adding the between-laboratory uncertainty (if considered appropriate) using Formula (20).

$$u_c^2(C_m) = u^2(m_{\text{sam}}) + u^2(m_{\text{BL}}) + u^2(V_{\text{sam, SPT}}) + u_{\text{bl}}^2 \quad (20)$$

where

u_{bl} is the between-laboratory uncertainty contribution.

12.3.7 Expanded uncertainty

The expanded uncertainty in C at the 95 % confidence level is obtained by multiplying $u_c(C_m)$ with a coverage factor of 2.

12.3.8 Uncertainty from performance criteria

When combining the uncertainties specified for the performance characteristics (12.2), a worst-case situation will result. The resulting combined relative uncertainty, calculated as described in 12.3.6, will be about 10 %. The expanded uncertainty will be 20 %.

ICS 13.040.30

Price based on 29 pages

Error! Reference source not found.

Annex A (informative)

Performance characteristics

A.1 Uncertainty estimates

The data in Table A.1 on uncertainty contributions were obtained from References [5-7, 9, 19, and 20] and validation of ISO 17734-1.

Table A.1 — Uncertainty contributions

Uncertainty contribution	Uncertainty %	Comments
<i>Sample volume</i>	4	For a 15 min air sample at a flow rate of 1 l·min ⁻¹
Sample flow – calibration	2	Calibration instrument specification
Sample flow – variation	3	Estimation
Sampling time	0,2	
Temperature during sampling	1	Estimation
Pressure during sampling	1	Estimation
<i>Analyte mass (weighing)</i> <i>Analyte mass (CLND)</i>	6 12	Isocyanate content in calibration standards determined by weighing or LC-CLND.
Analyte stability during storage	negligible	See References [5],[9], and [19]
Reaction/extraction efficiency	6	Calculated using titration data as reference material
Mass of isocyanate in calibration standards (weighing)	1	Isocyanate content in calibration standards determined by weighing or LC-CLND (see Reference [20])
Mass of isocyanate in calibration standards (CLND)	10	
Calibration lack-of-fit	1	
Response drift between calibrations	negligible	Instrumental drift is corrected by using internal standards (see References [6] and [7]).
Analytical precision	2	
Selectivity	negligible	LC-MS provides highly selective determinations.
<i>Blank level</i>	negligible	
<i>Between-laboratory variations</i>	10	Estimation, no data are available

A.2 Combined uncertainty

Error! Reference source not found.

If the isocyanate content in the calibration standards is based on accurately weighed amounts of isocyanates that are derivatized with DBA, the combined uncertainty is estimated to be 12 %. If the isocyanate content in the calibration standards is based on LC-CLND quantification, the combined uncertainty is estimated to be 16 %.

A.3 Expanded uncertainty

By using a coverage factor of 2, the expanded uncertainty is 24 % when using accurately weighed amounts of isocyanates that are derivatized with DBA. Using LC-CLND for determination of the isocyanate content in the calibration standards, the expanded uncertainty is 32 %. There will be an additional uncertainty contribution, so far not accounted for, from the collection efficiency, if collection according to a sampling convention is required.

In the case of determining prepolymeric isocyanates, the expanded uncertainty and combined uncertainty are assumed to be about the same as for the other isocyanates, if the composition in the bulk and the air samples is the same. This can be confirmed with LC-MS.

When analysing isocyanates such as prepolymeric isocyanates, oligomeric MDI, and technical mixtures of isocyanates for which pure defined standards are not available, bulk samples can be titrated. The total content of isocyanate functional groups can be calculated. To estimate the isocyanate concentration in air samples, one or several peaks in the chromatograms can be used as "indicators" of the isocyanate concentration in the sample, if the chromatogram of the air samples reflects the composition of the bulk samples. Interlaboratory comparison showed that TDI (80 %/20 % 2,4-TDI and 2,6-TDI) and an HDI mixture gave titration data that was about the same as the data obtained with several chromatographic methods tested. However, for oligomeric MDI, there is a bias of -30 %. The reason for this is at present not known. Raw results are corrected by dividing by (1 + bias). In this case, there is an additional uncertainty component of the combined uncertainty equal to 5 %.

Annex B (informative)

Examples

B.1 Example 1: Gluing

The emission of isocyanates was studied when 17 mg of MDI-based glue was heated to 80 °C.

At this temperature, no MDI was emitted from the sample, but 0,004 µg of HDI and 2,2 µg of IPDI were emitted from the glue (see Figure B.1).

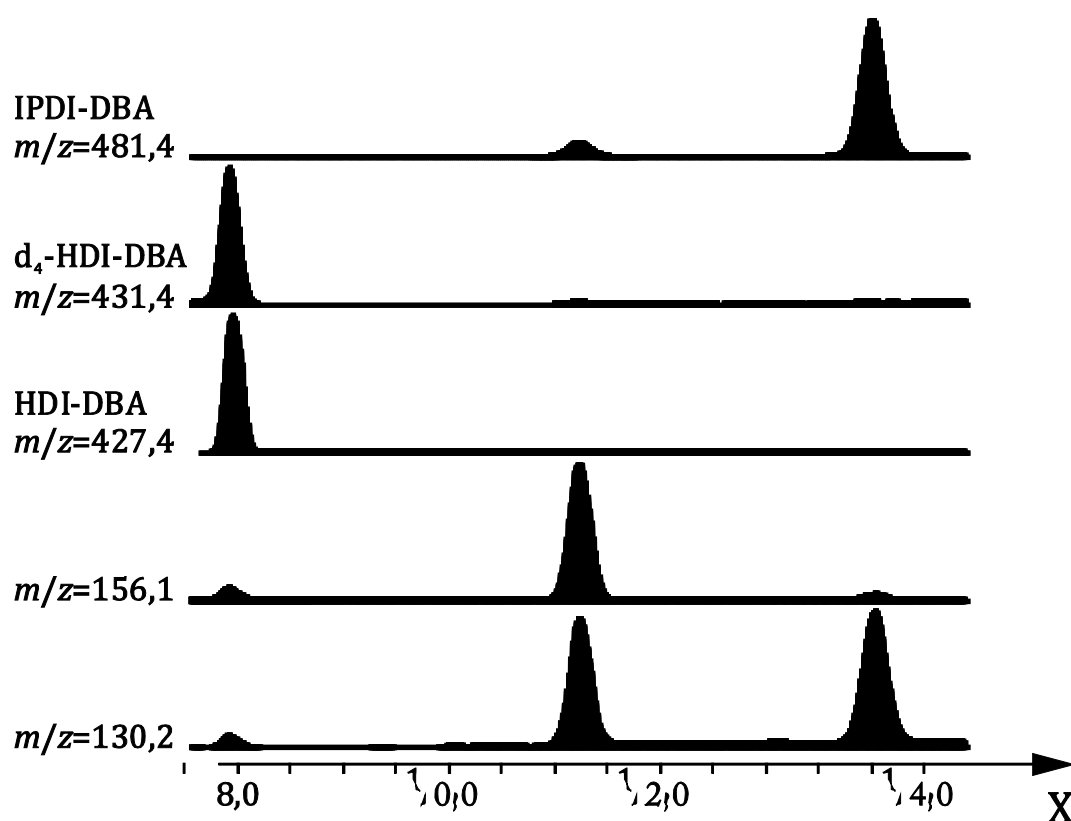

Key

X t_R , in min

NOTE Peak heights in terms of retention time, t_R , were adjusted to 100 % (arbitrary scale).

Figure B.1 — LC-MS-SIR chromatogram of the air sample in terms of retention time, t_R , as described in Example 1

Error! Reference source not found.

B.2 Example 2: Welding in PUR-coated car metal sheets

An air sample was collected during metal active gas (MAG) welding on a PUR-coated car in a car repair shop. Sampling was performed 20 cm above the welding spot for 15 min with a sampling flow of 1 l/min.

The air sample contained the following isocyanates (see Figure B.2):

- Isocyanic acid (ICA): 500 µg/m³;
- Methyl isocyanate (MIC): 57 µg/m³;
- Ethyl isocyanate (EIC): 21 µg/m³;
- Propyl isocyanate (PIC): 24 µg/m³;
- Hexamethylene diisocyanate (HDI): 72 µg/m³;
- 2,4-Toluene diisocyanate (TDI): 290 µg/m³;
- 2,6-TDI: 100 µg/m³;
- Methylenediphenyl diisocyanate (MDI): 2 µg/m³.

Air samples collected from this type of work operation can also contain amines and aminoisocyanates (see ISO 17734-2 for the simultaneous determination of isocyanates, aminoisocyanates, and amines).

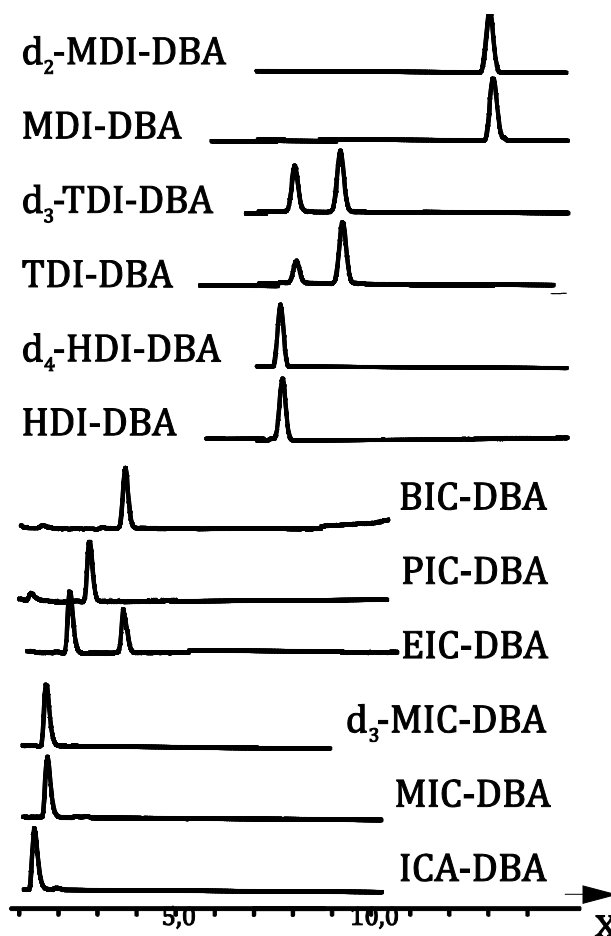

Key

X t_R , in min

NOTE Peak heights are adjusted to 100 % (arbitrary scale).

Figure B.2 — LC-MS-SIR chromatogram of the air sample described in Example 2

B.3 Example 3: Casting in sand moulds

Air samples ($n = 8$) were collected in an iron foundry during casting in sand moulds with furan resins. Four of the samples were collected in the breathing zone of the workers and two samples were collected 0,5 m above the mould during the casting operation. The other two samples were collected about 0,2 m above a transport pipe where melted steel was transported to a ladle. The pipe was insulated with mineral wool.

The air samples showed that ICA was emitted in high amounts both from the thermal degradation of the mould and from the mineral wool surrounding the transport pipe (see Table B.1).

Table B.1 — Concentrations of ICA and MIC in air samples collected in an iron foundry during casting in sand moulds with furan resins

Error! Reference source not found.

Sample	Collected air volume l	ICA $\mu\text{g}\cdot\text{m}^{-3}$	MIC $\mu\text{g}\cdot\text{m}^{-3}$
1. Breathing zone, worker 1	6	50	—
2. Breathing zone, worker 1	6	60	—
3. Breathing zone, worker 2	5	300	—
4. Breathing zone, worker 2	5	300	—
5. Above the insulated pipe	2	700	30
6. Above the insulated pipe	2	700	30
7. Above the mould	3	300	—
8. Above the mould	3	300	—

B.4 Example 4: Mass spectra of isocyanate-DBA derivatives

Mass spectrometry provided valuable information of the present compounds in a sample. Identification of the derivatives is made possible due to characteristic fragmentation patterns. For the DBA derivatives, the typical formed ions are $[\text{MH}]^+$, $[(\text{DBA})\text{H}]^+$ ($m/z = 130$), $[(\text{DBA})\text{CO}]^+$ ($m/z = 156$), $[\text{MH}-129]^+$, and $[\text{MNa}]^+$ (see Figure B.3).

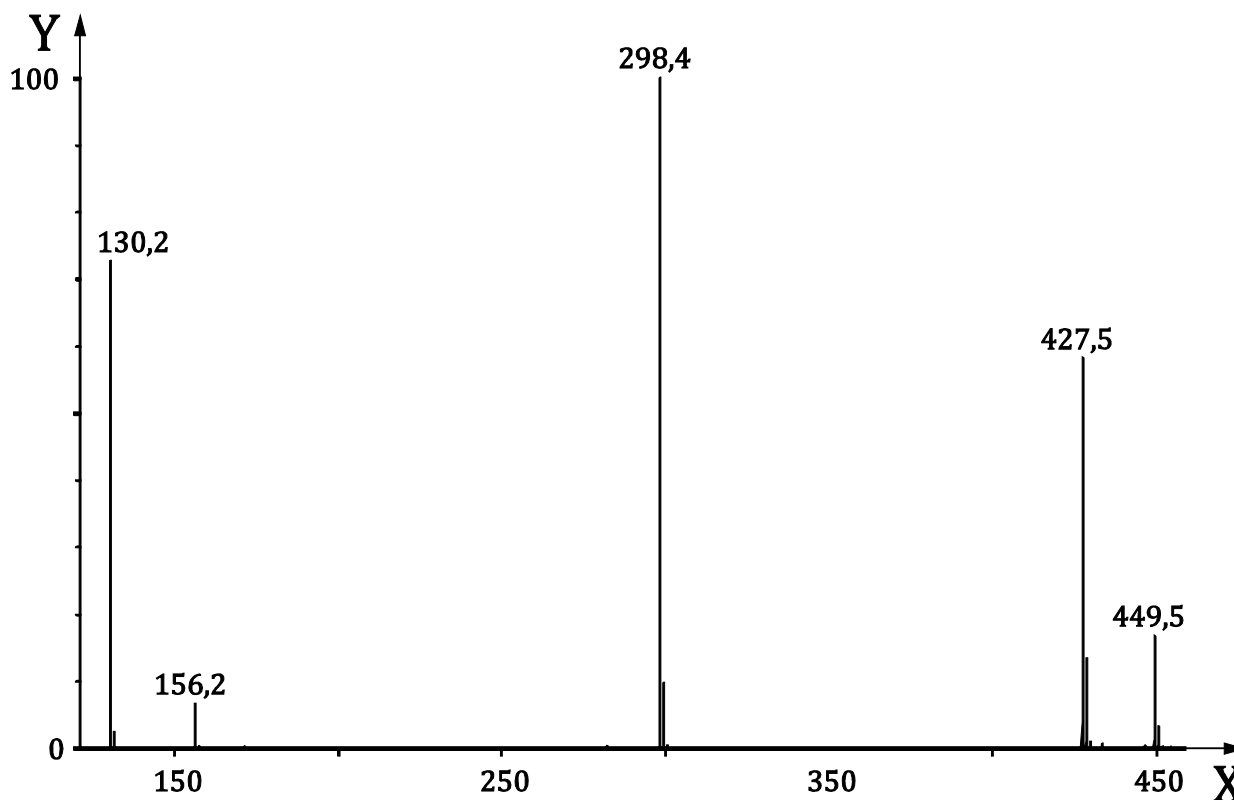

ICS 13.040.30

Price based on 29 pages

Error! Reference source not found.

Key

X m/z

Y relative intensity (RI), in percent

$m/z = 130,2$ [(DBA)H]⁺

$m/z = 156,2$ [(DBA)CO]⁺

$m/z = 298,4$ [MH-129]⁺

$m/z = 427,5$ [MH]⁺

$m/z = 449,5$ [MNa]⁺

Figure B.3 — LC-ESP mass spectra of HDI-DBA

Error! Reference source not found.

Annex C (informative)

Commercially available products

Product	Supplier	Product name	Product number
Standard solution (1 µg/ml)	Sigma Aldrich	DBA Isocyanate Mix	40141-U
Internal standard solution(1 µg/ml)	Sigma Aldrich	d ₉ -DBA Isocyanate Internal Standard Mix	40142-U
Dry sampler	Sigma Aldrich	ASSET™ ^a) EZ4-NCO Dry sampler for Isocyanates, pk 10	5027-U
Dry sampler	Sigma Aldrich	ASSET™ EZ4-NCO Dry sampler for Isocyanates, pk 50	5028-U

^a ASSET™ is an example of a suitable product available commercially. This information is given for the convenience of users of this part of ISO 17734 and does not constitute an endorsement by ISO of this product.

ICS 13.040.30

Price based on 29 pages

Error! Reference source not found.

Bibliography

- [1] BRORSON T., SANGÖ C., SKARPING G., RENMAN L. Evaluation of chromatographic methods for the determination of isocyanates in air. *Int. J. Environ. Anal. Chem.* 1990, **38** pp. 399–413
- [2] TINNERBERG H., SPANNE M., DALENE M., SKARPING G. Determination of Complex Mixtures of Airborne Isocyanates and Amines — Part 3. Methylenediphenyl Diisocyanate, Methylenediphenylamino Isocyanate and Methylenediphenyldiamine and Structural Analogues after Thermal Degradation of Polyurethane. *Analyst (Lond.)*. 1997, **122** (3), pp. 275–278
- [3] TINNERBERG H., KARLSSON D., DALENE M., SKARPING G. Determination of toluene diisocyanate in air using di-*n*-butylamine and 9-N-methylaminomethyl-antracene as derivatization reagents. *J. Liq. Chrom. Rel. Technol.* 1997, **20** (14), pp. 2 207-2 219
- [4] SPANNE M., TINNERBERG H., DALENE M., SKARPING G. Determination of Complex Mixtures of Airborne Isocyanates and Amines — Part 1. Liquid Chromatography with Ultraviolet Detection of Monomeric and Polymeric Isocyanates as their Dibutylamine Derivatives. *Analyst*. 1996, **121** (8), pp. 1095-1099
- [5] KARLSSON D., SPANNE M., DALENE M., SKARPING G. Determination of Complex Mixtures of Airborne Isocyanates and Amines — Part 4. Determination of Aliphatic Isocyanates as Dibutylamine Derivatives Using Liquid Chromatography and Mass Spectrometry. *Analyst (Lond.)*. 1998, **123** (1), pp. 117–123
- [6] KARLSSON D., SPANNE M., DALENE M., SKARPING G. Airborne thermal degradation products of polyurethane coatings in car repair shops. *J. Environ. Monit.* 2000, **2** (5), pp. 462–469
- [7] KARLSSON D., DAHLIN J., MARAND Å., SKARPING G., DALENE M. Determination of airborne isocyanates as di-*n*-butylamine derivatives using liquid chromatography and tandem mass spectrometry. *Anal. Chim. Acta.* 2005, **534** pp. 263–269
- [8] MARAND Å., KARLSSON D., DALENE M., SKARPING G. Solvent-free sampling with di-*n*-butylamine for monitoring of isocyanates in air. *J. Environ. Monit.* 2005, **7** pp. 335–343
- [9] KARLSSON D., DALENE M., SKARPING G. Determination of Complex Mixtures of Airborne Isocyanates and Amines — Part 5. Determination of low molecular weight aliphatic isocyanates as dibutylamine derivatives. *Analyst*. 1998, **123**, pp. 1 507-1 512
- [10] KARLSSON D., DALENE M., SKARPING G., MARAND Å. Determination of isocyanic acid in air. *J. Environ. Monit.* 2001, **3** pp. 432–436
- [11] KARLSSON D., DAHLIN J., SKARPING G., DALENE M. Determination of isocyanates, aminocyanates and amines in air formed during the thermal degradation of polyurethane. *J. Environ. Monit.* 2002, **4** pp. 216–222
- [12] MARAND Å., DAHLIN J., KARLSSON D., DALENE M., SKARPING G. Determination of technical grade isocyanates used in the production of polyurethane plastics. *J. Environ. Monit.* 2004, **6** pp. 606–614
- [13] ASTM D4629-02, *Standard Test Method for Trace Nitrogen in Liquid Petroleum Hydrocarbons by Syringe/Inlet Oxidative Combustion and Chemiluminescence Detection*, American Society for Testing and Materials

Error! Reference source not found.

- [14] ASTM D5762-05, *Standard Test Method for Nitrogen in Petroleum and Petroleum Products by Boat-Inlet Chemiluminescence*, American Society for Testing and Materials
- [15] ENV 12260:2003, *Water quality — Determination of nitrogen — Determination of bound nitrogen (TN_{+b}), following oxidation to nitrogen oxides*
- [16] DOMBROW B. *Polyurethanes*. Reinhold Publishing Corporation, New York, Second Edition, 1965
- [17] EN 482:2012, *Workplace exposure — General requirements for the performance of procedures for the measurement of chemical agents*
- [18] EN 13205:2002, *Workplace atmospheres — Assessment of performance of instruments for measurement of airborne particle concentrations*
- [19] TINNERBERG H., SPANNE M., DALENE M., SKARPING G. Determination of Complex Mixtures of Airborne Isocyanates and Amines — Part 2. Toluene Diisocyanate and Aminoisocyanate and Toluenediamine After Thermal Degradation of a Toluene Diisocyanate-Polyurethane. *Analyst*. 1996, **121** (8), pp. 1 101-1 106
- [20] TAYLOR E.W., QIAN M.G., DOLLINGER G.D. Simultaneous On-Line Characterization of Small Organic Molecules Derived from Combinatorial Libraries for Identity, Quantity, and Purity by Reversed-Phase HPLC with Chemiluminescent Nitrogen, UV, and Mass Spectrometric Detection. *Anal. Chem.* 1998, **70** (16), pp. 3 339–3 347
- [21] ISO 13137, *Workplace atmospheres — Pumps for personal sampling of chemical and biological agents — Requirements and test methods*

ICS 13.040.30

Price based on 29 pages

Error! Reference source not found.