

BUREAU OF INDIAN STANDARDS

DRAFT FOR COMMENTS ONLY

(Not to be reproduced without permission of BIS or used as an Indian Standard)

भारतीय मानक मसौदा
स्वचालित मापन प्रणालियों की प्रदर्शन विशेषताएँ
भाग 4 स्थिर स्तोत्रों से नाइट्रोजन आक्साइड
[IS 17148 (भाग 4) का पहला पुनरीक्षण]

Draft Indian Standard

**Performance Characteristics of
Automated Measurement Systems**

Part 4 Nitrogen Oxides from Stationary Sources

[*First Revision of IS 17148 (Part 4)*]

(ICS 13.040.40)

Air Quality Sectional Committee, CHD 35

Last Date for Comments: 12th December 2024

Air Quality Sectional Committee, CHD 35

NATIONAL FOREWORD

(Formal clause shall be added later)

Deterioration in air quality due to pollution is a pertinent global problem. Monitoring industrial emissions so as to minimize its environmental and health effects is a major concern in a developing economy like India. Automated measurement systems (AMS) help in continuous monitoring of emissions. For accurate and effective functioning, these measurement systems shall fulfill certain performance criteria. This standard has been developed to ensure production and availability of good quality AMS instruments in India. These standard forms a part of a series of standards on performance characteristics of AMS and it is applicable for the AMS utilized for determination of nitrogen oxides from stationary source emissions.

This standard was first published in 2020 as an identical adoption of ISO 10849: 1996 under dual numbering. This Part specifies a method for the determination of nitrogen oxides (NO_x) in flue gas of stationary sources and describes the fundamental structure and the key performance characteristics of automated measuring systems.

This Indian standard has been published in several parts. The other parts in this series are:

Part 1 Carbon monoxide, carbon dioxide and oxygen from stationary sources

Part 2 Particulate Matter from Stationary Sources

Part 3 Sulfur Dioxide from Stationary Sources

Part 5 Determination of the mass concentration of ammonia in flue gas from Stationary Sources

This first revision of the standard has been brought out to adopt the latest version of ISO 10849 : 2022. In this revision following modification have been done:

- a) The structure and the components have been updated to be similar to the latest editions of e.g. ISO 12039 (measurement of CO, CO₂ and O₂), ISO 17179 (measurement of NH₃), ISO 13199 (measurement of total VOC), ISO 25140 (measurement of CH₄), ISO 21258 (measurement of N₂O);
- b) Clause 3 has been updated (addition or deletion and change in terms and definitions);
- c) A new analytical technique has been added (Fourier transform infrared spectroscopy) for measurement of NO and NO₂ or NO_x;
- d) The performance characteristics and criteria as well as QA/QC procedures have been changed to harmonize with latest ISO standards;
- e) Examples of performance test results and the results of uncertainty calculation have been added for NO and NO₂ or NO_x measurement.

The text of ISO Standard has been approved as suitable for publication as an Indian Standard without deviations. Certain conventions and terminologies are, however, not identical to those used in Indian Standards. Attention is particularly drawn to the following:

- a) Wherever the words 'International Standard' appear referring to this standard, they should be read as 'Indian Standard'.
- b) Comma (,) has been used as a decimal marker in the International Standard, while in Indian Standards, the current practice is to use a point (.) as the decimal marker.

The Committee has reviewed the provisions of the following International Standards referred in this adopted standard and has decided that they are acceptable for use in conjunction with this standard.

<i>International Standard No</i>	<i>Title</i>
ISO 9169	Air quality — Definition and determination of performance characteristics of an automatic measuring system
ISO 14956	Air quality — Evaluation of the suitability of a measurement procedure by comparison with a required measurement uncertainty

In this adopted standard, reference appears to certain International Standards where the standard atmospheric conditions to be observed are stipulated which are not applicable to tropical/subtropical countries. The applicable standard atmospheric conditions for Indian conditions are (27 ± 2) °C and (65 ± 5) percent, relative humidity and shall be observed while using this standard.

In reporting the result of a test or analysis made in accordance with this standard, if the final value, observed or calculated, is to be rounded off, it shall be done in accordance with IS 2: 2022 'Rules for rounding off numerical values (*second revision*)'

FOR COMPLETE TEXT OF THE DOCUMENT, KINDLY REFER ISO 10849: 2022

Note: The technical content of the document has not been enclosed as these are identical with the corresponding ISO Standard. For obtaining the copy of the complete ISO Standard, please contact:

Scientist 'F' and Head
Chemical Department
Bureau of Indian Standards
Manak Bhavan, 9, Bahadur Shah Zafar Marg
New Delhi-110002
Telephone: 011-23236428
Email: chd@bis.gov.in or chd35@bis.org.in

**Stationary source emissions —
Determination of the mass
concentration of nitrogen oxides
in flue gas — Performance
characteristics of automated
measuring systems**

*Émissions de sources fixes — Détermination de la concentration en
masse des oxydes d'azote dans les effluents gazeux — Caractéristiques
de performance des systèmes de mesurage automatiques*

FOR B10 USE ONLY



FOR BIS USE ONLY



COPYRIGHT PROTECTED DOCUMENT

© ISO 2022

All rights reserved. Unless otherwise specified, or required in the context of its implementation, no part of this publication may be reproduced or utilized otherwise in any form or by any means, electronic or mechanical, including photocopying, or posting on the internet or an intranet, without prior written permission. Permission can be requested from either ISO at the address below or ISO's member body in the country of the requester.

ISO copyright office
CP 401 • Ch. de Blandonnet 8
CH-1214 Vernier, Geneva
Phone: +41 22 749 01 11
Email: copyright@iso.org
Website: www.iso.org

Published in Switzerland

Contents

	Page
Foreword.....	iv
Introduction.....	v
1 Scope.....	1
2 Normative references.....	1
3 Terms and definitions.....	1
4 Symbols and abbreviated terms.....	4
5 Principle.....	5
6 Description of the automated measuring systems.....	5
6.1 Sampling and sample gas conditioning systems.....	5
6.2 Analyser equipment.....	6
7 Performance characteristics and criteria.....	6
7.1 Performance criteria.....	6
7.2 Determination of the performance characteristics.....	7
7.2.1 Performance test.....	7
7.2.2 Ongoing quality control.....	7
8 Selection and installation procedure.....	7
8.1 Choice of the measuring system.....	7
8.2 Sampling.....	8
8.2.1 Sampling location.....	8
8.2.2 Representative sampling.....	8
8.3 Calculation.....	8
8.3.1 Conversion from volume to mass concentration for NO.....	8
8.3.2 Calculation of NO ₂ and NO _x concentrations.....	9
9 Quality assurance and quality control procedures.....	9
9.1 General.....	9
9.2 Frequency of checks.....	9
9.3 Calibration, validation and measurement uncertainty.....	10
10 Test report.....	10
Annex A (informative) Extractive NO, NO₂ or NO_x measurement systems.....	12
Annex B (informative) In situ NO and NO₂ measurement systems.....	22
Annex C (normative) NO₂-NO converter.....	26
Annex D (normative) Operational gases.....	28
Annex E (normative) Procedures for determination of the performance characteristics.....	29
Annex F (informative) Examples of results for the validation of NO_x AMS.....	37
Annex G (informative) Calculation of uncertainty of measurement of NO and/NO₂ or NO_x.....	41
Bibliography.....	47

Foreword

ISO (the International Organization for Standardization) is a worldwide federation of national standards bodies (ISO member bodies). The work of preparing International Standards is normally carried out through ISO technical committees. Each member body interested in a subject for which a technical committee has been established has the right to be represented on that committee. International organizations, governmental and non-governmental, in liaison with ISO, also take part in the work. ISO collaborates closely with the International Electrotechnical Commission (IEC) on all matters of electrotechnical standardization.

The procedures used to develop this document and those intended for its further maintenance are described in the ISO/IEC Directives, Part 1. In particular, the different approval criteria needed for the different types of ISO documents should be noted. This document was drafted in accordance with the editorial rules of the ISO/IEC Directives, Part 2 (see www.iso.org/directives).

Attention is drawn to the possibility that some of the elements of this document may be the subject of patent rights. ISO shall not be held responsible for identifying any or all such patent rights. Details of any patent rights identified during the development of the document will be in the Introduction and/or on the ISO list of patent declarations received (see www.iso.org/patents).

Any trade name used in this document is information given for the convenience of users and does not constitute an endorsement.

For an explanation of the voluntary nature of standards, the meaning of ISO specific terms and expressions related to conformity assessment, as well as information about ISO's adherence to the World Trade Organization (WTO) principles in the Technical Barriers to Trade (TBT), see www.iso.org/iso/foreword.html.

This document was prepared by Technical Committee ISO/TC 146, *Air quality*, Subcommittee SC 1, *Stationary source emissions*.

This second edition cancels and replaces the first edition (ISO 10849:1996), which has been technically revised.

The main changes are as follows:

- the structure and the components have been updated to be similar to the latest editions of e.g. ISO 12039 (measurement of CO, CO₂ and O₂), ISO 17179 (measurement of NH₃), ISO 13199 (measurement of total VOC), ISO 25140 (measurement of CH₄), ISO 21258 (measurement of N₂O);
- [Clause 3](#) has been updated (addition or deletion and change in terms and definitions);
- a new analytical technique has been added (Fourier transform infrared spectroscopy) for measurement of NO and NO₂ or NO_x;
- the performance characteristics and criteria as well as QA/QC procedures have been changed to harmonize with latest ISO standards;
- examples of performance test results and the results of uncertainty calculation have been added for NO and NO₂ or NO_x measurement.

Any feedback or questions on this document should be directed to the user's national standards body. A complete listing of these bodies can be found at www.iso.org/members.html.

Introduction

Nitrogen oxides are produced during most combustion processes. In fossil fuel combustion, nitrogen oxides are produced from nitrogen contained in the fuel and from the oxidation of nitrogen in the air used for combustion. The quantity of nitrogen oxides produced depends upon the nitrogen content of the fuel, the combustor design, and the combustor operating conditions.

In flue gases from conventional boiler combustion systems, the nitrogen oxides consist of approximately 95 % nitrogen monoxide (NO). The remaining oxide is predominantly nitrogen dioxide (NO₂) formed from the oxidation of NO when the flue gas temperature decreases. These two oxides (NO + NO₂) are generally designated as NO_x. It should be noted that in other processes the ratio of NO to NO₂ may be different and other nitrogen oxides may be present.

There are numerous ways of determining nitrogen oxides in the gases of combustion plants, both wet chemical/analytical methods and instrumental techniques.

FOR BIS USE ONLY

FOR BIS USE ONLY

Stationary source emissions — Determination of the mass concentration of nitrogen oxides in flue gas — Performance characteristics of automated measuring systems

1 Scope

This document specifies a method for the determination of nitrogen oxides (NO_x) in flue gas of stationary sources and describes the fundamental structure and the key performance characteristics of automated measuring systems.

The method allows continuous monitoring with permanently installed measuring systems of NO_x emissions.

This document describes extractive systems and in situ (non-extractive) systems in connection with a range of analysers that operate using, for example, the following principles:

- chemiluminescence (CL);
- infrared absorption (NDIR);
- Fourier transform infrared (FTIR) spectroscopy;
- ultraviolet absorption (NDUV);
- differential optical absorption spectroscopy (DOAS);

Other equivalent instrumental methods such as laser spectroscopic techniques can be used provided they meet the minimum performance requirements specified in this document. The measuring system can be validated with reference materials, in accordance with this document, or comparable methods.

Automated measuring system (AMS) based on the principles listed above has been used successfully in this application for the measuring ranges as shown in [Annex F](#).

2 Normative references

The following documents are referred to in the text in such a way that some or all of their content constitutes requirements of this document. For dated references, only the edition cited applies. For undated references, the latest edition of the referenced document (including any amendments) applies.

ISO 9169, *Air quality — Definition and determination of performance characteristics of an automatic measuring system*

ISO 14956, *Air quality — Evaluation of the suitability of a measurement procedure by comparison with a required measurement uncertainty*

3 Terms and definitions

For the purposes of this document, the following terms and definitions apply.

ISO and IEC maintain terminology databases for use in standardization at the following addresses:

- ISO Online browsing platform: available at <https://www.iso.org/obp>

— IEC Electropedia: available at <https://www.electropedia.org/>

**3.1
analyser**

analytical part in an extractive or in situ *automated measuring system* (3.2)

[SOURCE: ISO 12039:2019, 3.1]

**3.2
automated measuring system
AMS**

measuring system interacting with the flue gas under investigation, returning an output signal proportional to the physical unit of the *measurand* (3.9) in unattended operation

[SOURCE: ISO 9169:2006, 2.1.2, modified — Note is removed]

Note 1 to entry: For the purposes of this document, an AMS is a system that can be attached to a duct or stack to continuously or intermittently measure the mass concentration of NO, NO₂ or NO_x passing through the duct.

**3.3
in situ AMS**

non-extractive system that measures the concentration directly in the duct or stack

Note 1 to entry: In situ systems measure either across the stack or duct or at a point within the duct or stack.

**3.4
parallel measurements**

measurements taken on the same duct in the same sampling plane for the same period of time with the AMS under test and with the reference method at points a short distance from each other, providing pairs of measured values

Note 1 to entry: See 3.21.

**3.5
independent reading**

reading that is not influenced by a previous individual reading by separating two individual readings by at least four response times

**3.6
interference
cross-sensitivity**

negative or positive effect upon the response of the measuring system, due to a component of the sample that is not the measurand

**3.7
interferent
interfering substance**

substance present in the air mass under investigation, other than the *measurand* (3.9), that affects the response of AMS (3.2)

**3.8
lack-of-fit**

systematic deviation within the range of application, between the accepted value of a reference material applied to the measuring system and the corresponding result of measurement produced by the measuring system

Note 1 to entry: Lack-of-fit can be a function of the result of measurement.

Note 2 to entry: The expression “lack-of-fit” is often replaced in everyday language for linear relations by “linearity” or “deviation from linearity”.

[SOURCE: ISO 9169:2006, 2.2.9, modified — Note 2 is removed.]

3.9**measurand**

particular quantity subject to measurement

[SOURCE: ISO/IEC Guide 98-3:2008, B.2.9, modified— Example and Note is removed.]

3.10**NO₂/NO converter efficiency**

ratio with which the converter device of a NO_x analyser reduces NO₂ to NO

3.11**performance characteristic**

one of the quantities assigned to equipment in order to define its performance

Note 1 to entry: Performance characteristics can be described by values, tolerances, or ranges.

3.12**period of unattended operation**

maximum interval of time for which the performance characteristics remain within a predefined range without external servicing, e.g. refill, adjustment

[SOURCE: ISO 9169:2006, 2.2.11]

Note 1 to entry: The period of unattended operation is often called maintenance interval.

3.13**reference material**

substance or mixture of substances with a known concentration within specified limits, or a device of known characteristics

Note 1 to entry: Normally calibration gases, gas cells, gratings or filters are used.

[SOURCE: ISO 14385-1:2014, 3.20]

3.14**reference method**

measurement method taken as a reference by convention, which gives the accepted reference value of the measurand

Note 1 to entry: See [3.4](#).

3.15**transport time in the measuring system**

time period for transportation of the sampled gas from the inlet of the probe to the inlet of the measurement instrument

3.16**response time**

time interval between the instant when a stimulus is subjected to bring about a specified abrupt change and the instant when the response reaches and remains within specified limits around its final stable value, determined as the sum of the lag time and the rise time in the rising mode, and the sum of the lag time and the fall time in the falling mode

[SOURCE: ISO 9169:2006, 2.2.4]

Note 1 to entry: Lag time, rise time and fall time are defined in ISO 9169:2006.

3.17**span gas**

gas or gas mixture used to adjust and check the span point on the response line of the measuring system

Note 1 to entry: The concentration is often chosen around 70 % to 90 % of full scale.

3.18

span point

value of the output quantity (measured signal) of the automated measuring system for the purpose of calibration, adjustment, etc. that represents a correct measured value generated by reference gas

3.19

standard uncertainty

uncertainty of the result of a measurement expressed as a standard deviation

[SOURCE: ISO/IEC Guide 98-3:2008, 2.3.1]

3.20

uncertainty

parameter associated with the result of a measurement, that characterizes the dispersion of the values that could reasonably be attributed to the measurand

[SOURCE: ISO/IEC Guide 98-3: 2008, 2.2.3 modified — Note 1, 2 and 3 removed.]

3.21

validation of an automated measuring system

procedure to check the statistical relationship between values of the measurand indicated by the automated measuring system and the corresponding values given by parallel measurements implemented simultaneously at the same measuring point

3.22

zero gas

gas or gas mixture used to establish the *zero point* (3.23) on a calibration curve within a given concentration range

[SOURCE: ISO 12039:2019, 3.20]

3.23

zero point

specified value of the output quantity (measured signal) of the AMS and which, in the absence of the measured component, represents the zero crossing of the calibration line

4 Symbols and abbreviated terms

e_i	Residual (lack-of-fit) at level i
K	Coverage factor
N	Number of measurements
s_r	Standard deviation of repeatability
$u(\gamma_X)$	Combined uncertainty of X (NO or NO ₂) mass concentration
$U(\gamma_X)$	Expanded uncertainty of X (NO or NO ₂) mass concentration
M_x	Molar mass of X (NO or NO ₂ , g/mol)
V_M	Molar volume (22,4 l/mol at standard conditions, 273,15 K; 101,325 kPa)
φ_X	Volume fraction of X (NO or NO ₂)
γ_X	X (NO or NO ₂) mass concentration at standard conditions in mg/m ³ (273,15 K; 101,325 kPa)
γ_R	NO or NO ₂ mass concentration at reference conditions in mg/m ³ (273,15 K; 101,325 kPa; H ₂ O corrected)

\bar{x}	Average of the measured values x_i
x_i	i th measured value
\bar{x}_i	Average of the measured value at level i
\dot{x}_i	Value estimated by the regression line at level i
AMS	Automated measuring system
FTIR	Fourier transform infrared
NDIR	Non-dispersive infrared
NDUV	Non-dispersive ultraviolet
DOAS	Differential optical absorption spectroscopy
QA	Quality assurance
QC	Quality control

5 Principle

This document describes automated measurement systems for sampling, sample conditioning, and determining NO and NO₂ or NO_x content in flue gas using instrumental methods (analysers).

There are two types of automated measuring systems:

- extractive systems;
- in situ systems.

With extractive systems, a representative sample of gas is taken from the stack with a sampling probe and conveyed to the analyser through the sample line and sample gas conditioning system.

In situ systems do not require any sampling transfers out of the stack. For the installation of these systems, a representative place in the stack is to be chosen.

The systems described in this document measure NO and NO₂ or NO_x concentrations using instrumental methods that shall meet the minimum performance specifications given.

In most of the cases, it is considered that only NO is measured, because the NO₂ content is much smaller than NO. However, in some cases NO₂ may exist in large quantities and shall be taken into account, either by direct measurement or by using a converter of NO₂ to NO. The sampling is more complex.

6 Description of the automated measuring systems

6.1 Sampling and sample gas conditioning systems

Sampling and sample gas conditioning systems for extractive and in situ methods shall conform to ISO 10396.

In extractive sampling, these gases are conditioned to remove aerosols, particulate matter and other interfering substances before being conveyed to the instruments. Three kinds of extractive systems as well as non-extractive systems are described in ISO 10396:

- a) Cold-dry,
- b) Hot-wet and

- c) Dilution. In non-extractive sampling, the measurements are made in situ; therefore, no sample conditioning is required.

The details of the extractive sampling and sample gas conditioning systems are described in [Annex A](#) and two kinds of in situ system are illustrated in [Annex B](#).

6.2 Analyser equipment

Examples of the typical analytical methods available are described in [Annex A](#) and [Annex B](#).

The NO₂ to NO converter is necessary if NO₂ is measured with an NO analyser (only required in combination with extractive systems). The details of the converter and the test method for the performance characteristics are described in [Annex C](#).

AMS shall meet the performance characteristics as described in [Clause 7](#).

7 Performance characteristics and criteria

7.1 Performance criteria

[Table 1](#) gives the performance characteristics and performance criteria of the analyser and measurement system to be evaluated during performance test, by means of ongoing QA/QC in the laboratory and during field operation. Test procedures for the performance test are specified in [Annex E](#).

Table 1 — Performance characteristics and criteria of AMS for measurement of NO and NO₂

Performance characteristic	Performance criterion	Test procedure
Response time	≤ 200 s	E.2
Standard deviation of repeatability in laboratory at zero point	≤ 2,0 % of the upper limit of the lowest measuring range used	E.3.2
Standard deviation of repeatability (NO or NO ₂) in laboratory at span point	≤ 2,0 % of the upper limit of the lowest measuring range used	E.3.3
Lack-of-fit	≤ 2,0 % of the upper limit of the lowest measuring range used	E.4
Zero drift within 24 h	≤ 2,0 % of the upper limit of the lowest measuring range used	E.5
Span drift within 24 h	≤ 2,0 % of the upper limit of the lowest measuring range used	E.5
Zero drift within the period of unattended operation	≤ 3,0 % of the upper limit of the lowest measuring range used	E.6
Span drift within the period of unattended operation	≤ 3,0 % of the upper limit of the lowest measuring range used	E.6
Sensitivity to ambient temperature, for a change of 20 K in the temperature range specified by the manufacturer	≤ 5,0 % of the upper limit of the lowest measuring range used	E.7
Sensitivity to sample gas pressure, for a pressure change of 3 kPa	≤ 2,0 % of the upper limit of the lowest measuring range used	E.8
Sensitivity to sample gas flow for an extractive AMS	≤ 2,0 % of the upper limit of the lowest measuring range used	E.9
Sensitivity to electric voltage in the range -15 % below or +10 % above from the nominal voltage stated by the manufacturer	≤ 2,0 % of the upper limit of the lowest measuring range used	E.10
Cross-sensitivity	≤ 4,0 % of the upper limit of the lowest measuring range used	E.11

Table 1 (continued)

Performance characteristic	Performance criterion	Test procedure
Losses and leakage in the sampling line and conditioning system	$\leq 2,0$ % of the measured value	E.12 and E.13
Excursion of the measurement beam of cross-stack in situ AMS	≤ 2 % of the measured value of the lowest measuring range used	E.14
NO ₂ /NO converter efficiency if applicable	$\geq 95,0$ %	Annex C

7.2 Determination of the performance characteristics

7.2.1 Performance test

The performance characteristics of the AMS shall be determined during the performance test. The values of the performance characteristics determined shall meet the performance criteria specified in [Table 1](#). The procedures for the determination of these performance characteristics are specified in [Annex E](#).

The ambient conditions applied during the general performance test shall be documented.

The measurement uncertainty of the AMS measured values shall be calculated in accordance with ISO 14956 on the basis of the performance characteristics determined during the performance test and shall meet the level of uncertainty appropriate for the intended use. These characteristics may be determined either by the manufacturer or by the user.

7.2.2 Ongoing quality control

The user shall check specific performance characteristics during ongoing operation of the measuring system with a periodicity specified in [Table 2](#).

The measurement uncertainty during field application shall be determined by the user of the measuring system in accordance with applicable international or national standards. For process monitoring, the level of uncertainty shall be appropriate for the intended use. It can be determined by a direct or an indirect approach for uncertainty estimation as described in ISO 20988. The uncertainty of the measured values under field operation is not only influenced by the performance characteristics of the analyser itself but also by uncertainty contributions due to:

- the sampling line and conditioning system,
- the site specific conditions, and
- the reference materials used.

8 Selection and installation procedure

8.1 Choice of the measuring system

To choose an appropriate analyser, sampling line and conditioning unit, the following characteristics of flue gases should be known before the field operation:

- ambient temperature range;
- temperature range of the flue gas;
- water vapour content of the flue gas;
- dust loading of the flue gas;
- expected concentration range of NO, NO₂ or NO_x;

— expected concentration of potentially interfering substances.

To avoid long response time and memory effects, the sampling line should be as short as possible. If necessary, a bypass pump should be used. If there is a high dust loading in the sample gas, an appropriate heated filter shall be used.

Before monitoring emissions, the user shall verify that the necessary QA/QC procedures have been performed.

NOTE Information on QA/QC procedures is provided in ISO 14385-1 and ISO 14385-2.

8.2 Sampling

8.2.1 Sampling location

The sampling site shall be in an accessible location where a representative measurement can be made. In addition, the sampling location shall be chosen with regard to the safety of the personnel involved.

8.2.2 Representative sampling

It is necessary to ensure that the gas concentrations measured are representative of the average conditions inside the flue gas duct.

NOTE The selection of sampling points for representative sampling is described e.g. in ISO 10396, where gas stratification, fluctuations in gas velocity, temperature and others are discussed.

8.3 Calculation

8.3.1 Conversion from volume to mass concentration for NO

Results of the measurement for NO shall be expressed as mass concentrations at reference conditions.

If the NO concentration is provided as a volume fraction, [Formula \(1\)](#) shall be used to convert volume fraction of NO (10^{-6}), φ_{NO} , to NO mass concentrations, γ_{NO} :

$$\gamma_{\text{NO}} = \varphi_{\text{NO}} \cdot M_{\text{NO}} / V_{\text{M}} \quad (1)$$

where

γ_{NO} is the NO mass concentration at standard conditions in mg/m^3 (273,15 K; 101,325 kPa);

φ_{NO} is the volume fraction of NO (by volume, 10^{-6});

M_{NO} is the molar mass of NO (= 30,0 g/mol);

V_{M} is the molar volume (= 22,4 l/mol at 273,15 K and 101,325 kPa).

If necessary, the NO concentration measured in the wet gas should be corrected to the NO concentration at standard conditions (dry gas), using [Formula \(2\)](#):

$$\gamma_{\text{R}} = \gamma_{\text{NO}} \cdot \frac{100 \%}{100 \% - h} \quad (2)$$

where

γ_{R} is the NO mass concentration at standard conditions in mg/m^3 (273,15 K; 101,325 kPa; H_2O corrected);

h is the absolute water vapour content (by volume) (%).

The concentration of NO₂ measured in the wet gas can be corrected to the NO₂ concentration at standard conditions (dry gas), by using the [Formula \(2\)](#) by substituting NO₂ for γ_{NO_2} .

8.3.2 Calculation of NO₂ and NO_x concentrations

By using analytical instruments such as NDUV and FTIR, both NO and NO₂ can independently be measured.

When a sample gas flows through a converter (NO₂ to NO) to analytical instruments such as CL and NDIR, the total quantity of nitrogen oxides is obtained as:

$$[\text{NO}_x] = [\text{NO}] + [\text{NO}]_{\text{NO}_2}$$

where $[\text{NO}]_{\text{NO}_2}$ represents the concentration of NO originated from NO₂ in the sample gas. The concentration of NO_x is often described as that of NO, since NO_x in flue gases from conventional boiler combustion systems consist of approximately 95 % NO.

When the converter is bypassed, only [NO] is obtained. The amount of NO₂ thus can be calculated as:

$$[\text{NO}_x] - [\text{NO}] = [\text{NO}_2]$$

where $[\text{NO}_2]$ is derived from $[\text{NO}]_{\text{NO}_2} \cdot (M_{\text{NO}_2}/M_{\text{NO}})$.

9 Quality assurance and quality control procedures

9.1 General

Quality assurance and quality control (QA/QC) are important in order to ensure that the uncertainty of the measured values for NO or NO₂ is kept within the limits specified for the measurement task. The results of the QA/QC procedures shall be documented.

9.2 Frequency of checks

AMS shall be adjusted and checked after the installation and then during continuous operation. [Table 2](#) shows the minimum required test procedures and frequency of checks. The user shall implement the relevant procedures for determination of performance characteristics or procedures described in this clause and [Annex D](#). The results of the QA/QC procedures shall be documented.

Table 2 — Minimum checks and minimum frequency of checks for QA/QC during the operation

Check	Minimum frequency for permanently installed AMS	Test procedure
Response time	Once a year	E.2
Standard deviation of repeatability at zero point	Once a year	E.3.2
Standard deviation of repeatability at span point	Once a year	E.3.3
Lack-of-fit	Once a year and after any major changes or repair to the AMS, which will influence the results obtained significantly	E.4
Sampling system and leakage check	Once a year	E.12 and E.13
Beam alignment (in situ AMS only)	Once a year	According to manufacturer's manual

^a Analysers can be checked with internal gas cells or optical filters for this determination.

Table 2 (continued)

Check	Minimum frequency for permanently installed AMS	Test procedure
Light intensity attenuation through cleanliness and dust load (in situ AMS only)	According to manufacturer's requirements or period specified by national standard	According to manufacturer's manual
Cleaning or changing of particulate filters at the sampling inlet and at the monitor inlet	The particulate filters shall be changed periodically depending on the dust load at the sampling site. During this filter change the filter housing shall be cleaned.	According to manufacturer's manual
Zero drift ^a	Once in the period of unattended operation or period specified by national standard	E.6
Span drift ^a	Once in the period of unattended operation or period specified by national standard	E.6
Regular maintenance of the analyser	According to manufacturer's requirements	According to manufacturer's manual

^a Analysers can be checked with internal gas cells or optical filters for this determination.

The user shall implement a procedure to guarantee that the reference materials used meet the uncertainty requirement specified in [Annex D](#), e.g. by comparison with a reference gas of higher quality.

9.3 Calibration, validation and measurement uncertainty

The calibration and validation of the AMS shall be performed annually and after repair of the analyser in accordance with applicable national or international standards.

Permanently installed AMS for continuous monitoring shall be calibrated by comparison with

- a) an independent method of measurement or
- b) a reference material.

In either case, the validation of an automated measuring system shall include the determination of uncertainty of the measured value obtained by calibrating the AMS. Calculation of uncertainty of measurement of NO and NO₂ or NO_x is described in [Annex G](#). The AMS shall be subject to adjustments and functional tests in accordance with [9.2](#) before each calibration. This ensures that the measurement uncertainty is representative of the application at the specific plant.

The validation shall include the determination of the uncertainty of measured values obtained by comparison between reference gas or reference material with the AMS.

NOTE The determination of the uncertainty of measured values obtained by permanently installed AMS for continuous monitoring on the basis of a comparison with an independent method of measurement is described, e.g. in ISO 20988.

The uncertainty of the measured values shall meet the uncertainty criterion specified for the measurement objective.

10 Test report

If not specified otherwise, it shall include at least the following information:

- a) a reference to this document;
- b) description of the measurement objective;

- c) principle of gas sampling;
- d) information about the analyser and description of the sampling and conditioning line;
- e) identification of the analyser used, and the performance characteristics of the analyser, listed in [Table 1](#);
- f) operating range;
- g) sample gas temperature, sample gas pressure and optical path length through an optical cell (it is needed for only in situ measurement);
- h) details of the quality, purity and uncertainty in the concentration of the span gases used;
- i) description of plant and process; concentration range of pollutants and potential interferences;
- j) the identification and location of the sampling plane;
- k) the actions taken to achieve representative samples;
- l) a description of the location of the sampling point(s) in the sampling plane;
- m) a description of the operating conditions of the plant process;
- n) the changes in the plant operations during sampling;
- o) the sampling date, time, and duration;
- p) the time averaging on relevant periods;
- q) the measured values;
- r) the measurement uncertainty;
- s) the results of any QA/QC checks conducted arising from [Table 2](#);
- t) any deviations from this document.

Annex A (informative)

Extractive NO, NO₂ or NO_x measurement systems

A.1 General

A.1.1 Cold-dry extractive system

Many variants of this exist and [Figure A.1 a\)](#) is just an example of a typical arrangement of a complete measuring system for NO. This system is suitable for use with all the analysers that are described in [6.2](#). When NO₂ should be measured with a NO analyser, NO₂ to NO converter is to be used as shown in [Figure A.1 b\)](#).

The sampling of gas shall be representative, that is, the sampling location shall be typical of the entire duct with the guidelines given in ISO 10396. The sampling points for the measurement require a check for homogeneity. Prior to installation the uniformity of the gas stream should be checked.

FOR BIS USE ONLY

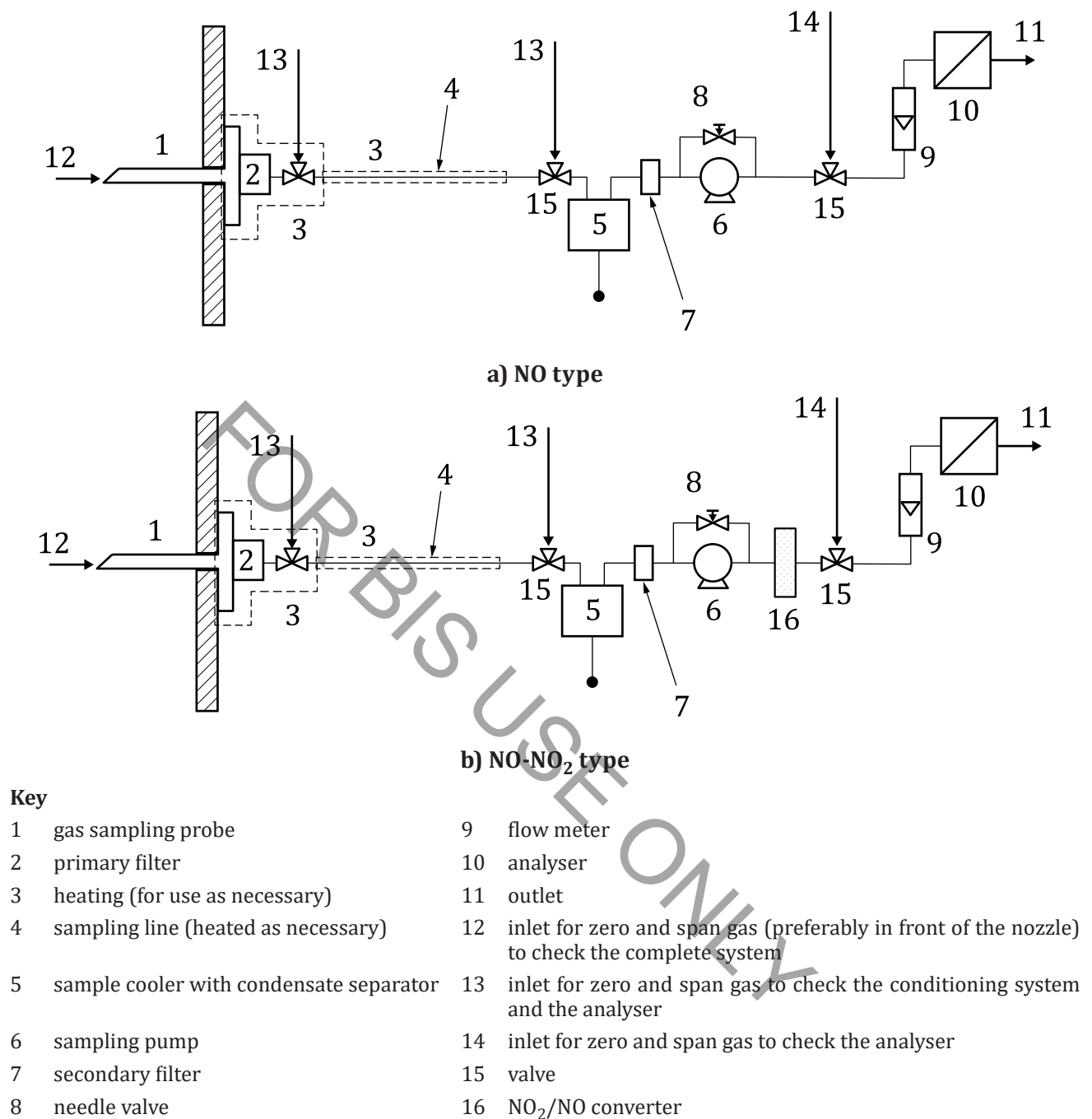

Figure A.1 — Cold-dry extractive system (example)

The components described in [A.1.2.1](#) to [A.1.2.8](#) have, for example, proven to be successful for measurements at gas-, oil- and coal-fired plants (precautions need be observed because of the high corrosiveness of condensable acid gases, e.g. HCl, SO₃ or NO₂).

A.1.2 Components for cold-dry extractive system

A.1.2.1 Sampling probe

The sampling probe shall be made of suitable, corrosion-resistant material. For gas temperatures up to 190 °C, polytetrafluoroethylene (PTFE) is an acceptable material. At temperatures higher than 250 °C,

stainless steel and certain other materials can alter the ratio of NO:NO₂. In this case, ceramic or glass material is required, if it is necessary to determine the ratio. Cooling may be considered necessary in order to maintain the gas concentrations in the flue gas.

A.1.2.2 Filter

The filter is needed to remove the particulate matter, in order to protect the sampling system and the analyser. The filter shall be made of ceramic, borosilicate glass or sintered metal. The filter shall be heated above the water or acid dew-point whichever is the higher. A filter that retains particles greater than 2 µm is recommended. The size of the filter shall be determined from the sample flow required and the manufacturer's data on the flow rate per unit area.

The temperature of the sampling probe and the filter shall be higher by at least 10 K to 20 K than the water or acid dew-point of the gases.

A.1.2.3 Sampling line

The sampling line shall be made of PTFE, PFA or stainless steel. The lines shall be operated at 15 K above the dew-point of condensable substances (generally the water or acid dew-point). The tube diameter should be appropriately sized to provide a flow rate that meets the requirements of the analysers, under selected line length and the degree of pressure drop in the line as well as the performance of the sampling pump used.

A.1.2.4 Moisture removal system (Sample cooler or permeation dryer)

The moisture removal system shall be used to separate water vapour from the flue gas. The dew point shall be sufficiently below the ambient temperature to ensure that ambient air temperatures do not affect the separation of water from the gases. A cooling temperature of 2 °C to 5 °C is suggested. Sufficient cooling is required for the volume of gas being sampled and the amount of water vapour that it contains.

The design of the sample gas cooler shall be such that absorption of NO₂ in the condensate is restricted to a minimum. This ensures that loss of NO₂ dissolved in the condensate, which is drained from the sample cooler, is at a minimum. The use of a permeation dryer can ensure that NO₂ losses are minimal.

A.1.2.5 Sampling pump (corrosion-resistant)

A sampling pump is used to withdraw a continuous sample from the duct through the sampling system. This may be a diaphragm pump, a metal bellows pump, an ejector pump, or other pump types. The pump shall be constructed of corrosion-resistant material. The performance of the pump shall be such that it can supply the analyser with the gas flow required. In order to reduce the transport time in the measuring system and the risk of physicochemical transformation of the sample, the gas flow can be greater than that required for the analytical units, and should be pulseless to ensure constant and even flow.

For the hot-wet extractive system ([A.1.3](#)), the pump shall be operated at a minimum of 180 °C, or 10 K to 15 K above the acid dew-point of the gases.

A.1.2.6 Secondary filter

The secondary filter is needed to remove the remaining particulate material, in order to protect the pump and the analyser. A filter that retains particles greater than 1 µm is recommended. Acceptable materials are PTFE, borosilicate glass or sintered metals. The size of the filter shall be determined from the sample flow required and the manufacturer's data on the flow rate per unit area.

A.1.2.7 Flow controller and flow meter

The flow controller and flow meter are used to set the required flow rate. They shall be constructed of corrosion resistant material.

A.1.2.8 NO₂/NO converter

The NO₂/NO converter is necessary if NO₂ shall be measured with an NO analyser (only possible in combination with extractive systems). The details of the converter and the test method for the performance characteristics are described in [Annex C](#).

A.1.3 Hot-wet extractive system

When analysers with a hot sample cell are used, the automated measuring system as shown in [Figure A.2](#) is often applied.

In addition to the cold-dry extractive system, there is also automated measuring system for the NO_x measurement that heats the sample gas to above water and acid dew-points (or the dew-point of other condensable substances) to avoid losses of NO₂. In this case, the system can be simplified. It is important that all the components carrying the sample gas to the analyser are also heated above water and acid dew-points.

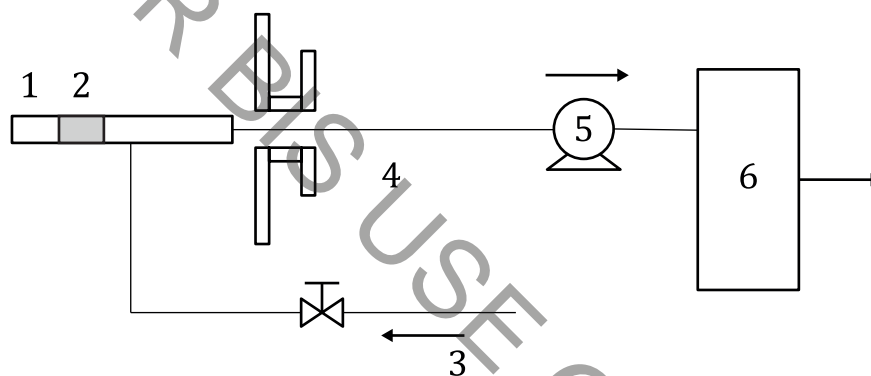

Key

- 1 sampling probe, heated (if necessary)
- 2 particle filter (in-stack or out-stack)
- 3 zero and span gas inlet
- 4 heated sampling line
- 5 sampling pump, heated
- 6 analyser with heated sample cell

Figure A.2 — Diagram of the hot optical measuring system (example: Hot-wet type)

A.1.4 Dilution extractive system

The dilution technique is an alternative to hot gas monitoring or sample gas drying. The flue gas is diluted with a dilution gas which shall be free from the species being measured [3].

The dilution ratio shall be chosen according to the objectives of the measurement and shall be compatible with the range of the analytical unit. It shall remain constant throughout the period of the test, because the calibration frequency of the measurement unit depends, among other things, on the stability of the dilution ratio. The water dew-point shall be reduced so as to reduce the risks of condensation in the gas monitoring system. The measured values always refer to the wet gas.

Many types of devices are suitable for use in dilution systems, such as:

- calibrated apertures (capillaries, sonic nozzles, needle valves, etc.);
- flow meters by volume or mass;
- pressure and/or flow regulators;

An example of diagram of the dilution probe is shown in [Figure A.3](#).

NOTE Dilution ratios are dependent upon changes in the flue gas density. Changes in the flue gas temperature, molecular weight and total stack pressure can affect the ratio and resultant concentration measurements and can need recording.

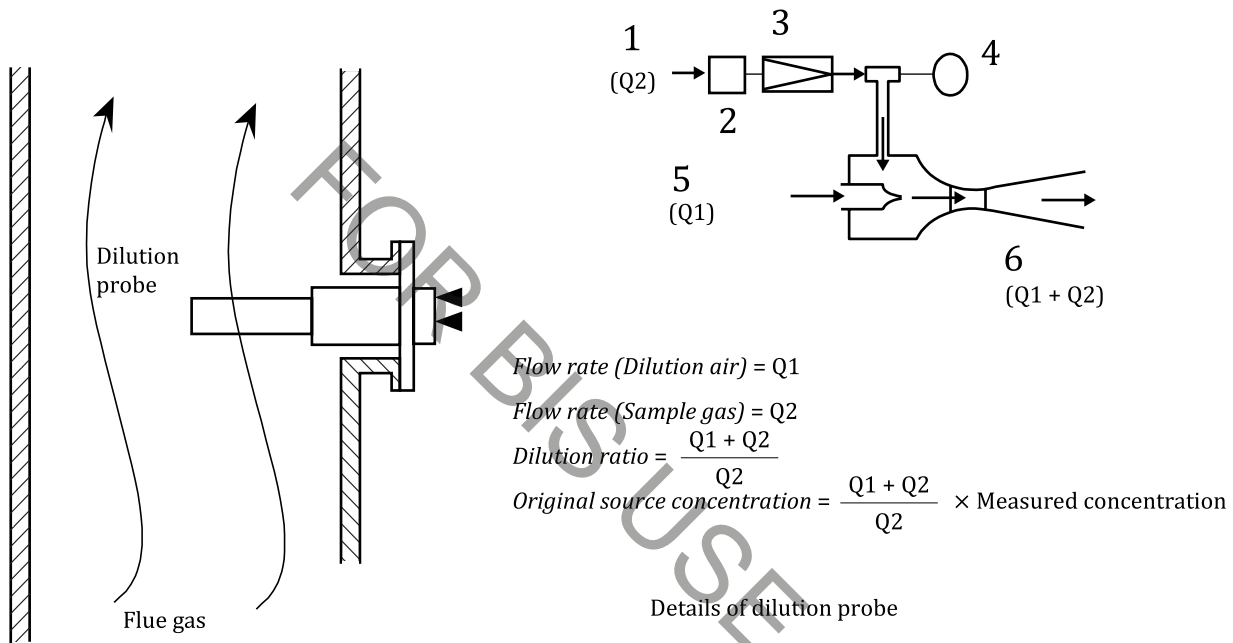

Key

- 1 sample gas (Q2:flow rate)
- 2 particle filter
- 3 critical orifice
- 4 vacuum gauge
- 5 dilution air (Q1:flow rate)
- 6 diluted sample gas (Q1 + Q2: flow rate of sample gas)

Figure A.3 — Diagram of the automated measuring system (example: Dilution extractive type)

A.2 Measuring principles of analysers

A.2.1 Chemiluminescence method

The principle of the chemiluminescence method for the determination of the mass concentration of nitrogen oxides in ambient air is described in ISO 7996[5].

If NO reacts with ozone (O₃), NO₂ is formed. Part of this NO₂ is in a photochemically excited state. When returning to the basic state, these NO₂ molecules can radiate light in the wavelength range of 590 nm to 3 000 nm. The intensity of this light depends on the NO content and is influenced by the pressure and presence of other gases.

[Figure A.4](#) shows the basic arrangement of a chemiluminescence analyser.

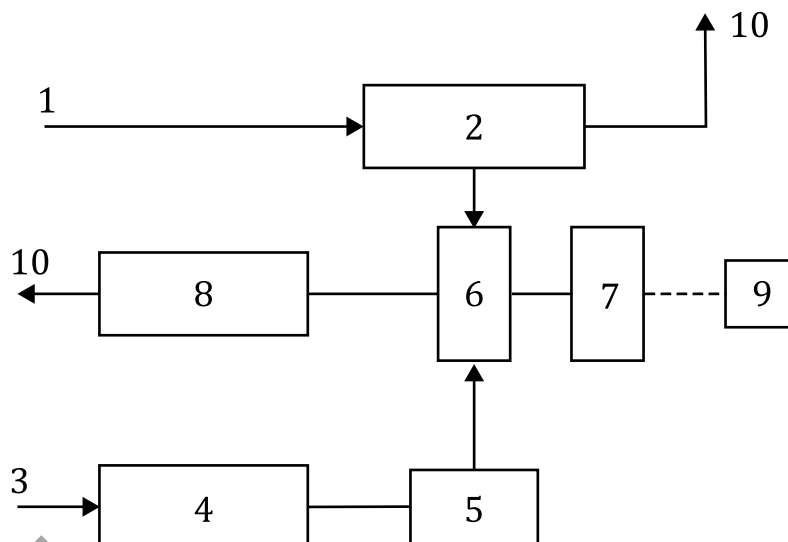
**Key**

1	sample gas	6	reaction chamber
2	flow rate control unit	7	photodetector
3	gas containing oxygen	8	ozone decomposition unit
4	flow rate control unit	9	signal
5	ozone generator	10	waste gas

Figure A.4 — Basic arrangement of a chemiluminescence analyser (example)

There are atmospheric pressure and low-pressure analysers, depending on the pressure in the reaction chamber. Some analysers have built-in NO₂/NO converters and, because of their structure, give signals for NO, NO_x and NO₂ either simultaneously or in sequence.

Interference due to carbon dioxide (CO₂) and water vapour in the sample gas is possible due to quenching of the chemiluminescent reaction. The extent of the quenching depends on the CO₂ and H₂O concentrations and the type of analyser used.

A.2.2 Infrared absorption technique

The non-dispersive infrared absorption method is based on the principle that gases consisting of molecules with different atoms absorb infrared radiation at a unique wavelength. The measurement technique makes use of the principle as follows:

a) Dual beam method

The radiation emitted from an IR source is divided into two beams and then modulated, one beam passing through the sample cell and the other through the reference cell containing an IR inactive gas, usually nitrogen. If the sample gas contains NO, some of the IR energy is absorbed and the difference in IR energy reaching the detector is proportional to the amount of NO present. The detector is designed so that it is only sensitive to the NO-specific wavelengths. An example of diagram of a dual-beam type NDIR analyser is shown in [Figure A.5](#).

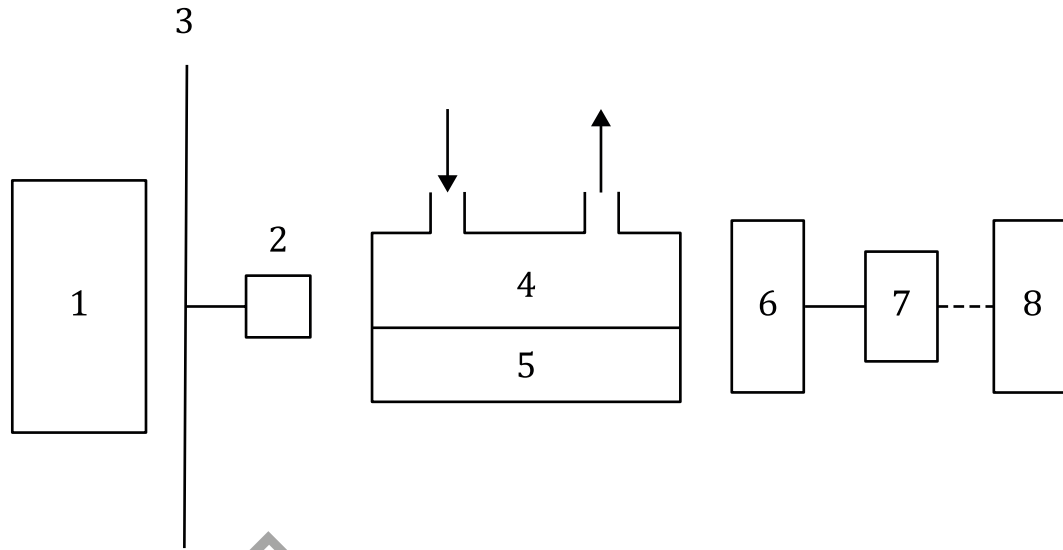

Key

- | | | | |
|---|---------------|---|----------------|
| 1 | IR source | 5 | reference cell |
| 2 | chopper motor | 6 | detector |
| 3 | chopper wheel | 7 | electronics |
| 4 | sample cell | 8 | display |

Figure A.5 — Diagram of a dual-beam type NDIR analyser (example)

b) Single beam method

There are at least three types of single beam methods:

- Use of interference filters, with one filter at the absorption band for the gas being measured and the other filter at the reference wavelength. The gas concentration is then a function of the ratio of the measured and reference wavelengths. A tuneable filter with varying band pass wavelength may be employed instead of multiple filters.
- In the gas filter correlation method the measurement interference filter is replaced with a gas filter; otherwise the method is similar to above. The analyser consists of the gas correlation filters, which are composed of the sample gas filter filled with a high level of the measurand gas including NO or NO₂ and the reference gas filter filled with the correlation zero gas (N₂), and the chopper wheel. After the introduction of the sample gas into the sample cell, the gas correlation filters and the chopper wheel are rotated constantly. The gas analyser measures the differential IR absorption of a beam which alternatively passes through the sample gas filter and the reference gas filter. This gives better sensitivity and reduction of cross-sensitivity effects. An example of diagram of gas filter correlation type NDIR analyser is shown in [Figure A.6](#).

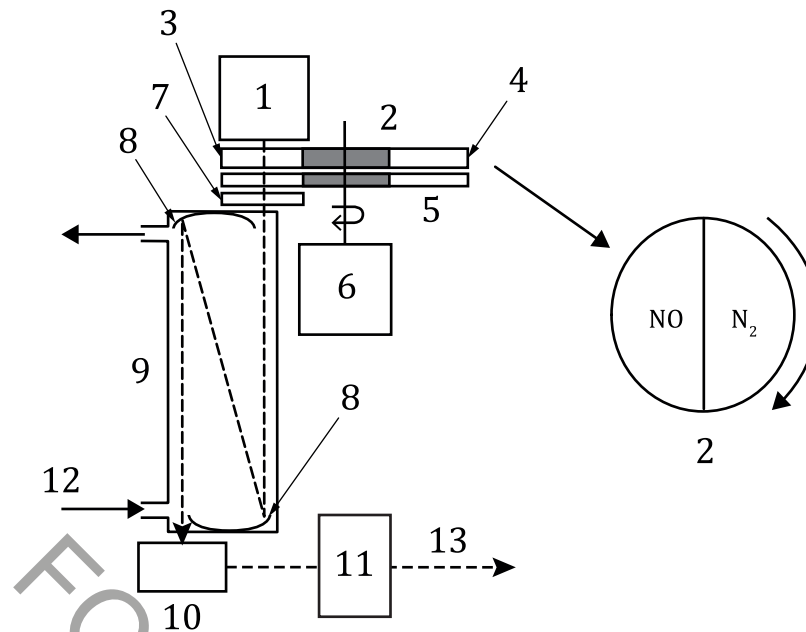
**Key**

- | | | | |
|---|------------------------|----|------------------|
| 1 | IR source | 8 | mirror |
| 2 | gas correlation filter | 9 | sample cell |
| 3 | sample gas filter | 10 | detector |
| 4 | reference gas filter | 11 | amplifier |
| 5 | chopper wheel | 12 | sample gas inlet |
| 6 | chopper motor | 13 | output signals |
| 7 | optical filter | | |

Figure A.6 — Diagram of gas filter correlation type NDIR analyser

- Cross-modulation type non-dispersive infrared analyser detects the difference of infrared absorption caused by alternatively introducing the sample gas and the gas for reference (e.g. air with NO/NO₂, etc. removed) to the measurement cell. The difference measured is the level due to the measurand and in this way the effects of interfering components are removed. An example of diagram of cross-modulation type NDIR analyser is shown in [Figure A.7](#).

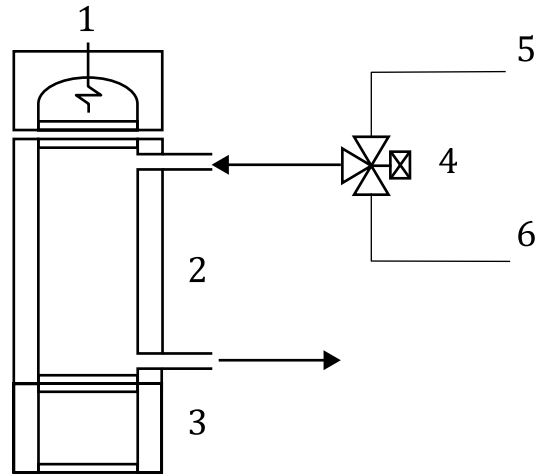

Key

- 1 IR source
- 2 sample cell
- 3 part for detection (optical filter and detector)
- 4 solenoid valve
- 5 sample gas
- 6 gas for reference

Figure A.7 — Diagram of cross-modulation type NDIR analyser

c) Fourier transform infrared spectroscopy

In a two-beam interferometer typically used for FTIR, the light emitted from infrared source is collimated and directed to a beam splitter. Part of the light passes through the beam splitter to a mirror, and the rest of the light is reflected to another mirror. Depending on the interferometer design, one or more mirrors are made to move, and as a result the beams will have travelled over different distances. When the two beams are reflected back to the beam splitter, there will be a phase difference between them. The combined output beam exiting the interferometer will have varying intensity as a function of the optical path difference (mirror position). This varying intensity signal is called the interferogram and it is linked to the wavelength spectrum by the Fourier Transformation. The spectrum is obtained in an FTIR instrument by recording the interferogram, applying some digital signal processing to it (apodization, filtering, phase correction) and computing its inverse Fourier transformation. The spectrum obtained is evaluated against established library spectra to derive the concentration of the gaseous species of interest (NO and NO₂). An example of diagram of Fourier transform infrared analyser is shown in [Figure A.8](#).

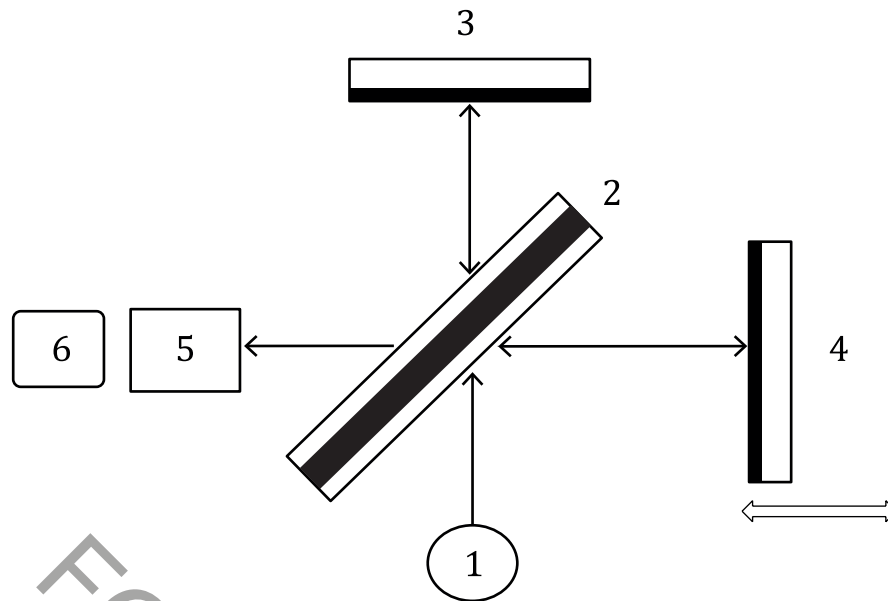
**Key**

- 1 IR source
- 2 beam splitter (half-silvered mirror)
- 3 fixed mirror
- 4 moving mirror
- 5 sample cell
- 6 detector

Figure A.8 — Diagram of Fourier transform infrared analyser (example)

A.2.3 Ultraviolet absorption technique

The non-dispersive ultraviolet absorption method is based on the principle that gases consisting of molecules with different atoms absorb ultraviolet radiation at a unique wavelength. The non-dispersive ultraviolet (NDUV) methods use the same principles as those described in [A.2.2](#) (a) and (b).

The NDUV analyser typically consists of the following principal components:

- light source (deuterium arc lamp, high pressure mercury lamp and others);
- optical and/or gas filters;
- measurement cell;
- photodetector;
- calibration cell to be used for QC drift check.

Annex B (informative)

In situ NO and NO₂ measurement systems

B.1 Measuring principle based on in situ NO and NO₂ measurement with differential optical absorption spectroscopy (DOAS) technique

B.1.1 General

An example of an in situ DOAS is shown below. The analysis principle is based upon measurement of unconditioned NO and NO₂ in the stream. NO and NO₂ levels are determined by direct measurement with a differential optical absorption spectroscopy (DOAS) analyser. For the correction to dry standard conditions it is recommended to measure water vapour together with the NO and NO₂ concentration.

NOTE Analysers based on NDIR, FTIR and NDUV principles are also offered for in situ measurements.

B.1.2 Differential optical absorption spectroscopy (DOAS)

The analyser with a high-pressure xenon lamp measures the total absorption spectrum of the flue gas in the stack in the range of 200 nm to 2,000 nm and the data are stored in the analyser memory (computer). The spectrum is divided by a 'zero' or system reference spectrum, recorded under conditions where no absorption for the measurement gases is present.

By dividing the two spectra, the total light absorption along the light beam is obtained. This may be due to gaseous pollutants in the gas, but also to dust or variations in the light intensity. As it is only gas molecules that cause rapid or narrowband variations in the absorption spectra, the slow or broadband variations, which cause a rise in the gradient, are mathematically removed.

Now all that remains are the rapid (narrowband) variations. The obtained spectrum is mathematically compared with the stored spectrum of the light source. The differential absorption spectrum is calculated, this calculation being the basis for the calculation of the concentration of the compound(s). The calculated spectrum consists of a well-balanced summation of the reference spectra for the analysis concerned.

Typical measurement wavelength used for NO is 215 nm – 226 nm and that for NO₂ is 330 nm – 550 nm.

B.2 In situ cross duct measuring systems

B.2.1 General

The in situ DOAS measuring system consists of a transmitter and receiver unit. The two units are mounted opposite each other directly on the pipe or stack. [Figure B.1](#) shows a typical arrangement of an in situ measuring system based on DOAS for NO and NO₂.

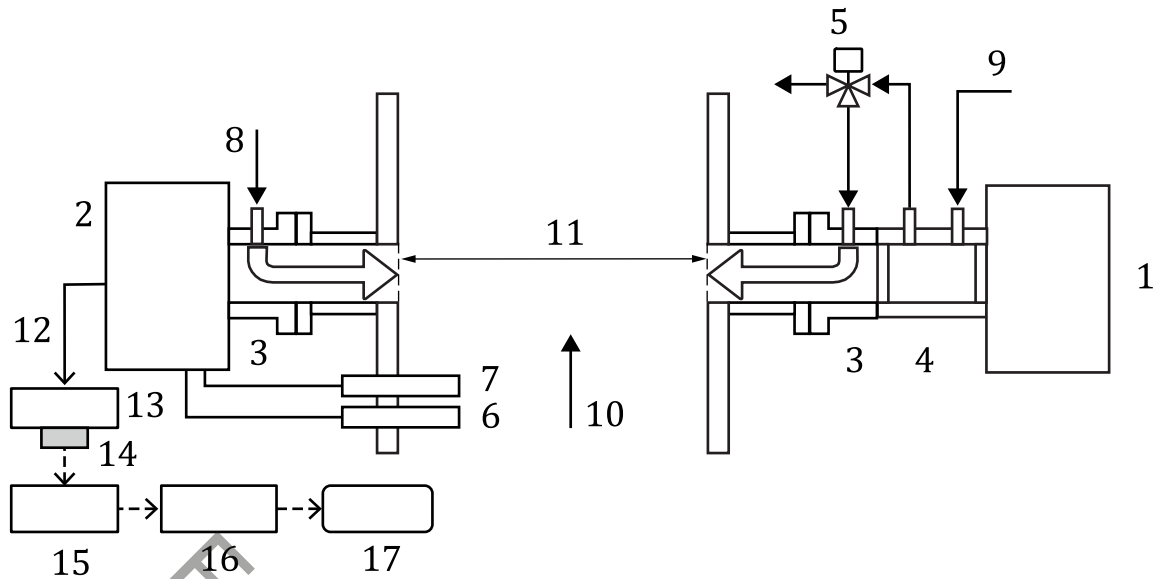

Key

- | | |
|--|----------------------|
| 1 transmitter unit | 10 stack gas region |
| 2 receiver unit | 11 measurement path |
| 3 purging flanges | 12 fibre optic cable |
| 4 validation cell | 13 spectrometer |
| 5 three-way valve | 14 detector |
| 6 pressure sensor (if the duct has constant conditions, it is not required) | 15 electronics |
| 7 temperature sensor (if the duct has constant conditions, it is not required) | 16 computer |
| 8 purge gas | 17 data |
| 9 purge gas, span gas or zero gas | |

Figure B.1 — Diagram of an in situ DOAS measuring system (example)

B.2.2 Components of an in situ DOAS measuring system (cross duct)

B.2.2.1 Transmitter and receiver unit

The transmitter unit contains a light source such as a xenon lamp and the receiver unit contains a photo detector. The light beam is emitted from the lamp located in the transmitter unit. The ultraviolet light passes through the gas and strikes the photo detector in the receiver unit.

B.2.2.2 Optical window purge

The purging flanges have two functions. First, the flanges are used to mount the transmitter or receiver unit on the pipe. Second, the purging flange has a connection port for the purging.

If required by the application, purge gas is applied to keep the windows clean in order to prevent the contamination of the optical components by the flue gas. The purge medium enters the purging flange and flows in the direction of the duct, where it is mixed with the flue gas. Instrument air is usually used as a flange purge gas. The purge flow depends on the conditions and is typically between 20 l/min and 50 l/min.

B.2.2.3 Validation cell

To verify the functionality of the DOAS measuring system, a validation procedure can be conducted regularly.

One method for validation is to apply an external validation cell, which is permanently mounted in the optical path between the pipe and the transmitter/receiver unit. An alternative method is to use a gas filled cell with stable concentration.

During the validation procedure, the validation cell is flushed with test gas or gas filled validation cell is temporarily moved into the optical path respectively.

The gas concentration required for both methods depends on the optical path length and validation cell, as well as the measuring range. Typically test gas with a concentration equivalent to 70 % to 90 % of full span is used.

B.2.2.4 Pressure and temperature sensor

Due to the in situ installation, varying gas pressures and gas temperatures in flue gas may have an effect on the measurement signal. If the parameters exceed the maximum acceptable variations, pressure and/or temperature readings can be applied to provide the relevant corrections for gas pressure or temperature to the DOAS measuring system.

B.3 In situ point measuring systems

B.3.1 General

The in situ point measuring system consists of a transceiver unit and a probe. The beam is typically transmitted through a short path of sample gas stream and reflected by the mirror at the tip of the probe. [Figure B.2](#) shows a typical arrangement of an in situ point measuring system

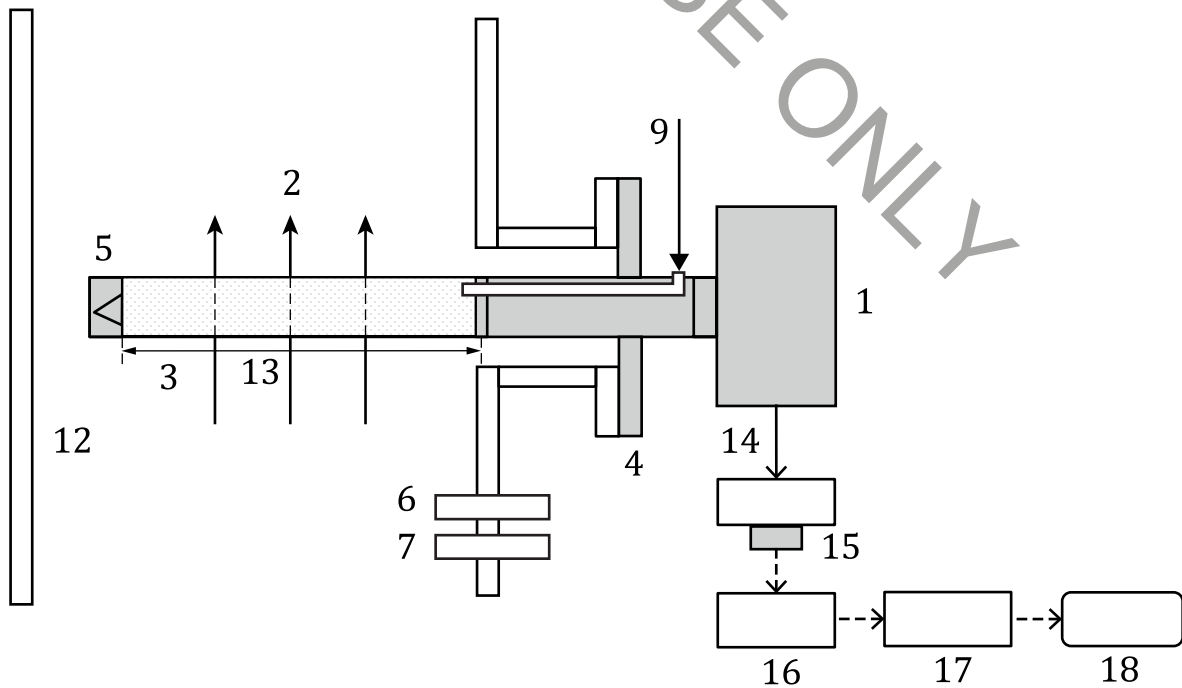

a) Filter type (side view of the probe)

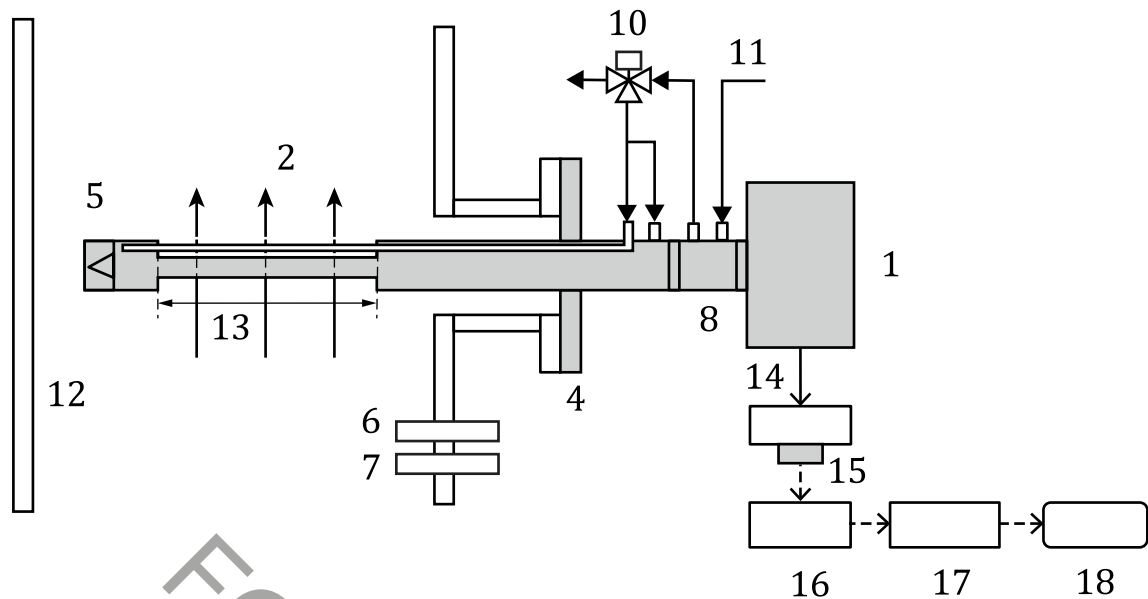

b) Non-Filter type (side view of the probe)

Key

1	transceiver unit	10	three-way valve
2	probe	11	purge gas, span gas or zero gas
3	probe filters	12	stack gas region
4	probe flange	13	measurement cell or cavity
5	mirror	14	spectrometer
6	pressure sensor (if the duct has constant conditions, it is not required)	15	detector
7	temperature sensor (if the duct has constant conditions, it is not required)	16	electronics
8	validation cell	17	computer
9	span gas or zero gas	18	data

Figure B.2 — Example of an in situ DOAS measuring system (point monitor)**B.3.2 Components of an in situ DOAS measuring system (point monitor)****B.3.2.1 Instrument transceiver**

A transceiver is a device comprising both a transmitter and a receiver. The component of the instrument sensing the response of the measurement cell and generate an electrical signal that corresponds to the concentration of the gas being measured.

B.3.2.2 Measurement cell

A cell or cavity exposed to the gas stream, for the purpose of producing an electro-optical response to the gas concentration at the end of the probe.

B.3.2.3 Probe filter

A porous ceramic or sintered metal tube or screen minimizes the interference of particulate matter with the gas measurement. If little effect of particulate matter on the measurement is expected, it is possible to use a non-filter probe.

Annex C (normative)

NO₂-NO converter

C.1 General

When NO₂ is measured with a NO analyser, a converter of NO₂ to NO is to be used. The test method for evaluating the efficiency of the converter is described here.

C.2 Principle of converters

Different types of converters exist, for example:

- carbon converters;
- carbon-molybdenum converters;
- stainless steel converters;
- thermal converters.

In some situations (e.g. when ammonia is present in the sample gas), interferences can occur depending on the operating temperature of the converter. In these cases, it is necessary to take into account such possibilities when selecting the converter type.

The converter can be bypassed with a three-way valve. If the sample gas flows through the converter, the total quantity (NO + NO₂) is obtained; when the converter is bypassed, the NO content is obtained. The amount of NO₂ can be calculated as the difference between NO_x and NO.

C.3 Check of the efficiency concerning NO₂ to NO

C.3.1 General

The converter shall have an efficiency > 95 %, which can be tested using test gases containing NO₂ in synthetic air, or with a converter efficiency tester. This method is described in detail in ISO 7996 and it is not suitable if the NO analyser is prone to interference by ozone.

C.3.2 Test of converter efficiency using test gas containing NO₂

For analysers with two reaction chambers, adjust the NO_x analyser on the NO and NO_x channel with a NO concentration around the emission limit value. Make sure that both channels give the same value and record the values.

Apply a NO₂ containing gas with a known concentration (as mentioned in [D.5](#)) to the analyser.

Record the NO_x and NO concentration. Wait at least 6 response times between the readings of the NO_x and NO concentrations. A measurement shall be taken as the average of a time period of at least three response times.

Calculate the converter efficiency by [Formula \(C.1\)](#)

$$\text{Conv. Eff. (\%)} = \frac{(\text{NO}_x)_u - (\text{NO})_u}{(\text{NO}_2)_i} \times 100 \quad (\text{C.1})$$

where

- Conv. Eff. (%) is the converter efficiency in percentage;
- $(\text{NO}_x)_u$ is the NO_x reading with NO₂ containing gas;
- $(\text{NO})_u$ is the NO reading with NO₂ containing gas;
- $(\text{NO}_2)_i$ is the NO₂ concentration of the NO₂ containing gas applied to the analyser.

Perform the determination of the converter efficiency three times and report the average of the three determinations. The value of the efficiency shall meet the performance criterion specified in [Table 1](#).

C.3.3 Test of converter efficiency using efficiency tester

The principle of an efficiency tester is shown in [Figure C.1](#). A constant flow of a NO calibration gas is mixed with a constant flow of air or oxygen, that contains different amounts of ozone, produced by an adjustable ozone generator. Ozone reacts with NO to produce NO₂. Thus the total amount of nitrogen oxides (NO + NO₂) remains constant, while the ratio (NO:NO₂) changes.

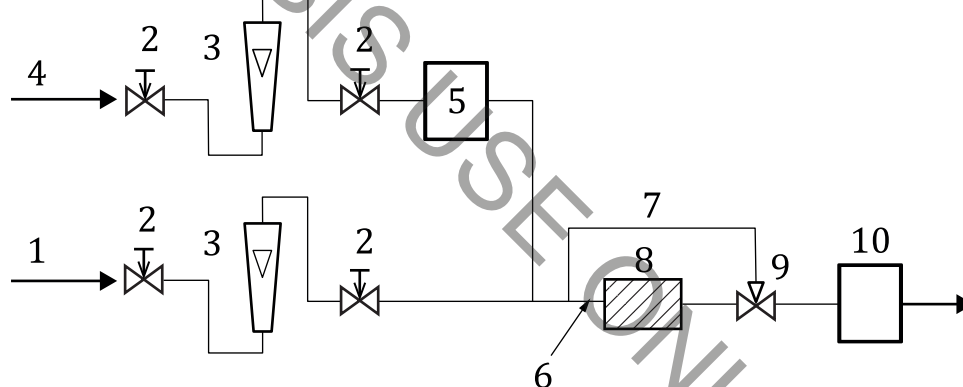

Key

- | | | | |
|---|--------------------|----|--|
| 1 | NO calibration gas | 6 | flow path to NO _x measurement |
| 2 | flow regulator | 7 | flow path to NO measurement |
| 3 | flow meter | 8 | NO ₂ /NO converter |
| 4 | air or oxygen | 9 | three-way valve |
| 5 | ozone generator | 10 | NO analyser |

Figure C.1 — Principle of an efficiency tester for NO₂/NO converters

If the converter efficiency is >95 %, the signal of the analyser, combined with the tested converter, remains nearly constant. The signal of every different concentration is compared with the signal of the gas mixture containing NO only (with the ozone generator switched off). At each different ozone concentration, the concentration of NO and (NO + NO₂) of the gas mixture shall be determined.

Annex D (normative)

Operational gases

D.1 General

Several operational gases are required when using this document.

D.2 Zero gas

Zero gas shall not contain compounds which interfere with the measuring efficiency of the instruments. For all analysers, pure nitrogen (5,0 grade, with the impurity of components to be measured less than the analytical detection limit), purified ambient air or other mixtures of O₂ and N₂ shall be used.

The concentration of the species of interest within the zero gas shall not exceed 1,0 % of the measuring range used.

D.3 Span gas

Span gas shall consist of NO in pure nitrogen. It shall have a known concentration with a maximum permissible expanded uncertainty of 2,0 % of its nominal value traceable to applicable standards. The span gas concentration should be about 70 % to 90 % of the upper limit of the selected measuring range.

D.4 Reference gas

Reference gas shall consist of NO in pure nitrogen. It shall have a known concentration with a maximum permissible expanded uncertainty of 2,0 % of its nominal value traceable to applicable standards.

D.5 Test gas for checking the efficiency of NO₂/NO converter

Test gas for checking the converter efficiency shall consist of NO₂ in synthetic air or any suitable device which uses traceable gases to verify the efficiency of the NO₂ converter. The concentration shall be in the range of the NO/NO_x concentration expected.

Annex E (normative)

Procedures for determination of the performance characteristics

E.1 General

Before any tests are being performed the warm-up time specified by the manufacturer shall be taken into account. If the warm-up time is not specified, a minimum of 2 h should be taken.

Before determining the performance characteristics of an AMS, the instrument shall be set up according to the manufacturer's requirements and according to the procedure detailed in [9.3](#).

During the test conditions for each individual performance characteristic, the values of the following parameters shall be constant within the specified range stated below:

- surrounding temperature ± 2 °C;
- sampling pressure $\pm 0,2$ kPa;
- supply voltage ± 1 % of the nominal line voltage (except for the voltage dependence test).

For the determination of the various performance characteristics reference gases with a known uncertainty of concentration shall be used.

NOTE Response time, repeatability at zero and at span level, lack-of-fit, cross-sensitivity, zero drift and span drift, sensitivity to ambient temperature, sensitivity to electric voltage of in situ systems can be measured with an external test cell.

E.2 Response time

In order to establish response time, lag time, rise time and fall time, a step function of the measurand shall be input to the continuous automatic measuring system. Unless otherwise specified in the terms of reference, the step produced by the test facility shall have a rise time (between 10 % and 90 % of the step change) less than 10 % of the averaging time to be applied during the tests. The step change of the test facility shall correspond to at least 60 % of the measuring range (see [Figure E.1](#)). If rise time and fall time differ, the longer one is to be taken for the computation of the response time.

For instruments where transient oscillations occur in approach to the final output signal, the final output signal is considered as reached when the oscillations fall to within 10 % of the input step.

NOTE A significant difference between the rise time and the fall time indicates memory effects, i.e. dependence of a result of measurement on the values of the measurand during previous measurement(s).

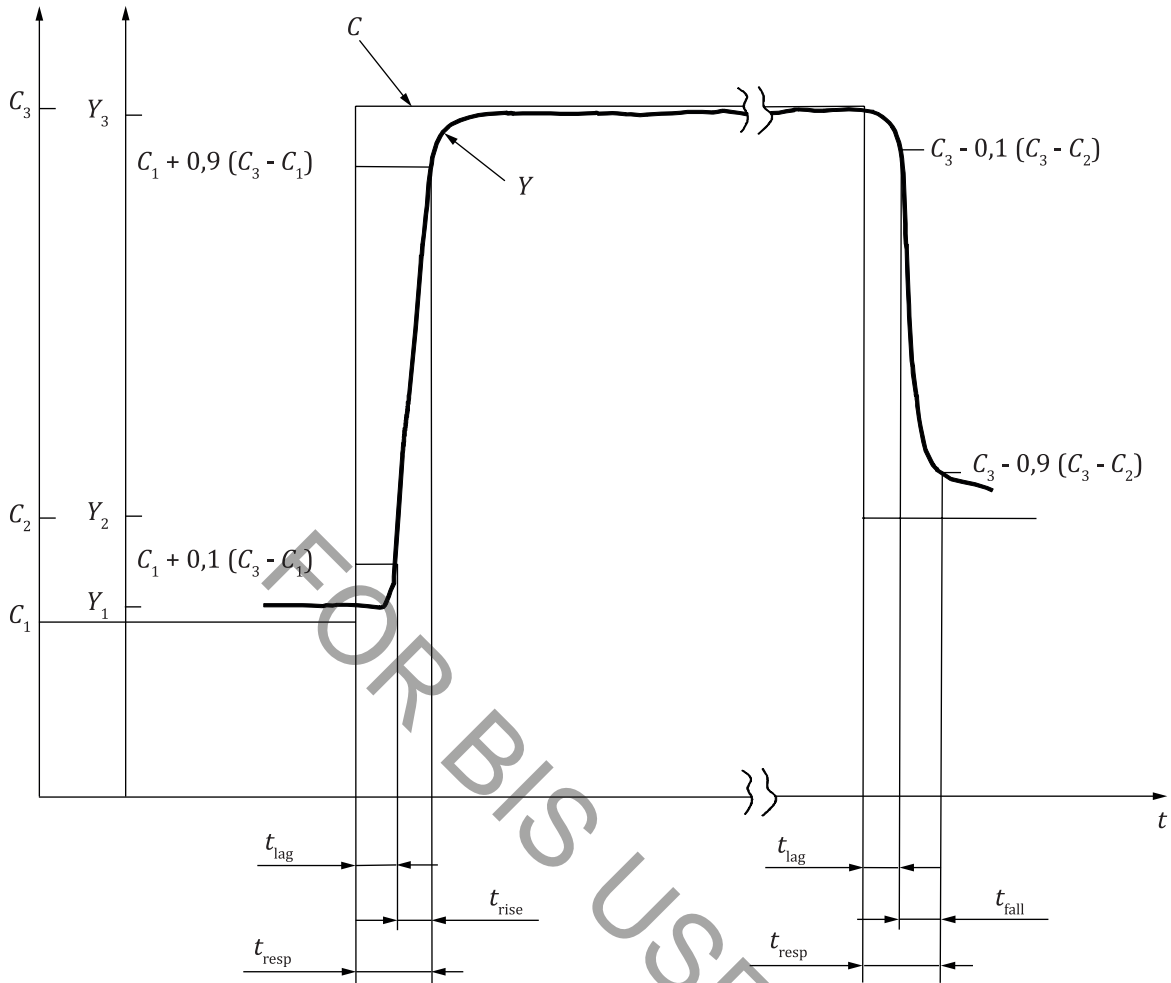

Key

- C_i value of the measurand in reference material i
- Y_i output signal obtained by measuring the measurand in reference material i
- t_{lag} lag time
- t_{rise} rise time
- t_{fall} fall time
- t_{resp} response time

Figure E.1 — Illustration of the time characteristics of an automated measuring system; Change of the output signal Y (output) after a change of the reference value C (input) as a function of time t

E.3 Repeatability at zero and at span level

E.3.1 General

To determine repeatability at zero and at span level, several measurements are conducted at zero and at a span concentration according to the procedures in [E.3.2](#) and in [E.3.3](#). Standard deviation and repeatability are calculated for both series of measurement (zero and span value) in accordance with ISO 9169.

E.3.2 Standard deviation of repeatability in laboratory at zero point

The standard deviation of repeatability at zero point shall be determined by application of a reference material at the zero point (zero gas). First adjust the zero point of the analyser. Then zero gas shall be applied to the sample inlet.

If the standard deviation of repeatability at zero point is determined during the lack-of-fit test, the reference material at zero concentration applied during the test shall be used.

The measured values of the AMS at zero point shall be determined after application of the reference material by waiting the time equivalent to one independent reading and then put in a span gas or go back to flue gas and then measure zero gas, at least 10 times.

The measured values obtained shall be used to determine the standard deviation of repeatability at zero point using [Formula \(E.1\)](#):

$$s_r = \sqrt{\frac{\sum (x_i - \bar{x})^2}{n-1}} \quad (\text{E.1})$$

where

s_r is standard deviation of repeatability;

x_i is the i th measured value;

\bar{x} is the average of the measured values x_i ;

n is the number of measurements.

The standard deviation of repeatability at zero point shall meet the performance criterion specified in [Table 1](#).

E.3.3 Standard deviation of repeatability in laboratory at span point

The standard deviation of repeatability at span point shall be determined by application of a reference material at the span point (span gas). The span gas shall be applied to the sample inlet. If the standard deviation of repeatability at span point is determined during the lack-of-fit test, the highest value of reference material applied during the test shall be used.

The measured values of the AMS at span point shall be determined after application of the reference material by waiting the time equivalent to one independent reading and then put in a zero gas or go back to flue gas and then measure span gas, at least 10 times. The measured signals obtained shall be used to determine the standard deviation of repeatability at span using [Formula \(E.1\)](#).

The standard deviation of repeatability at span point shall meet the performance criterion specified in [Table 1](#).

E.4 Lack-of-fit (linearity)

The lack-of-fit (linearity) shall be checked in the laboratory by feeding zero gas and at least four test gases with concentrations evenly distributed over the selected measuring range. The different gas concentrations may be produced using a dilution system.

The test gases shall be applied in an order, which avoids hysteresis effects.

Measure the test gas at each concentration with their accepted value c_i at least 3 consecutive measurements, each averaged over at least one response time.

The residuals e_i (lack-of-fit) shall be determined on the basis of a linear regression as described in ISO 9169. In this test procedure, a regression line is established between the instrument readings of the

AMS (x values) and the test gas values (c values). In the next step, the average \bar{x}_i of AMS readings at each test gas level is calculated. Then the deviation (residual) of the average to the corresponding value, \dot{x}_i , estimated by the regression line is calculated according to [Formula \(E.2\)](#):

$$e_i = |\dot{x}_i - \bar{x}_i| \quad (\text{E.2})$$

The relative residuals, $e_{i, \text{rel}}$, which is calculated by dividing e_i by the upper limit of the lowest measuring range used shall meet the performance criterion specified in [Table 1](#). If the performance criterion is not met, the instrument response shall be corrected until the performance criterion is met.

E.5 Zero drift and span drift for performance test

Zero and span drifts are estimated by applying at least 10 sequences of zero and span level, evenly distributed over a period of 24 h, and calculating for each concentration the slope of a linear regression, according to ISO 9169.

The zero and span gases should be applied to the AMS at the beginning of the test and then reapplied during the 24 h period as described above and should meet the performance criterion specified in [Table 1](#).

E.6 Zero drift and span drift for periodical test

Instrument adjustments with zero and span gases or with other reference materials shall be carried out at least once in the period of unattended operation. Tests for instruments for periodical measurements shall be carried out at the beginning of each measurement series.

The zero and span gas or other reference materials shall be used under the same flow and pressure conditions as for measurement conditions. For zero and span gas the sample port of the instrument or a procedure according to the manufacturer's instructions should be used. The deviations between the measured values at the zero point and at the span point and the nominal values shall meet the performance criterion specified in [Table 1](#).

E.7 Sensitivity to ambient temperature, for a change of 20 K in the temperature range specified by the manufacturer

Determine how the zero and span values of the AMS are influenced by changes in ambient temperature by using a climatic chamber which can control ambient temperature from -20 °C to $+50\text{ °C}$, within limits of $\pm 1,0\text{ K}$.

In the case of AMS installed outdoors, the following temperatures shall be set in the climatic chamber in the given order of sequence:

$20\text{ °C} \rightarrow 0\text{ °C} \rightarrow -20\text{ °C} \rightarrow 20\text{ °C} \rightarrow 50\text{ °C} \rightarrow 20\text{ °C}$.

In the case of AMS installed at temperature-controlled locations, the following temperatures shall be set in the given order of sequence:

$20\text{ °C} \rightarrow 5\text{ °C} \rightarrow 20\text{ °C} \rightarrow 40\text{ °C} \rightarrow 20\text{ °C}$.

After a sufficient equilibration period, the measured signals of the AMS at zero point and at span point shall be determined at each temperature by waiting the time equivalent to one independent reading and then recording three consecutive individual readings. The three individual readings shall be averaged.

Wait at least 6 h between each temperature change in the environmental chamber, to allow the AMS to equilibrate, before taking further readings.

Alternatively, it is recommended to monitor the reading from the AMS following each temperature change. If the instrument stabilizes in less than six hours, then the test laboratory may reduce the equilibration period. However, objective and verifiable evidence to support this will need to be recorded.

The AMS shall remain switched on when varying the ambient temperature in the environmental chamber.

The deviations between the average reading at each temperature and the average reading at 20 °C shall be determined. The deviations shall meet the applicable performance criteria specified in [Table 1](#) for all temperatures. The test shall be repeated three times at the zero point and three times at the span point. If the AMS meets the performance criterion by a factor of two or more for the first test, then any subsequent repeats (of the three) may be omitted.

The individual readings, averages and deviations at each temperature as well as the maximum deviation at zero point and at span point shall be reported.

E.8 Sensitivity to sample gas pressure, for a pressure change of 2 kPa

Determine the influence of variations in sample gas pressure on the response of the AMS. The sample shall be nitrogen containing the measured component at a concentration of between 70 % and 80 % of the upper limit of the lowest range.

NOTE The effect of sample gas pressure typically applies to in-situ AMS, but not to extractive AMS, since the sample gas is conditioned and typically not subject to significant variations of temperature and pressure once within the analyser.

For evaluation of the sensitivity to sample gas pressure of in-situ AMS, usually a temperature controlled cell (in most cases with a standard length of 1m optical path) is used, which is purged with zero or span gas and the gas pressure of the cell can be modified with a connected pump.

Measure the output signal of the AMS when the sample gas pressure is at

- ambient atmospheric pressure;
- approximately 3 kPa above ambient atmospheric pressure, within limits of $\pm 0,2$ kPa;
- approximately 3 kPa below ambient atmospheric pressure, within limits of $\pm 0,2$ kPa.

During the measurement period the temperature shall be held stable to within $\pm 1,0$ K.

The measured signals of the AMS shall be determined at each pressure by waiting the time equivalent to one independent reading and then recording three consecutive individual readings. The three individual readings shall be averaged.

The deviations between the average reading at each pressure and the average reading at the ambient atmospheric pressure shall be determined. The deviations shall meet the applicable performance criteria specified in [Table 1](#).

The individual readings, averages and deviations at each pressure as well as the maximum deviation shall be reported.

E.9 Influence of the sample gas flow for extractive AMS

The AMS shall initially be operated with the flow rate prescribed by the manufacturer. This flow rate shall then be changed to the lowest flow rate specified by the manufacturer.

NOTE Influence of the sample gas flow typically applies to extractive AMS, since in situ AMS mostly are not influenced by flow rate.

If the manufacturer's documentation permits only minor tolerances these are binding and shall not be extended.

The measured signals of the AMS at the zero point and span point shall be determined at both flow rates by waiting the time equivalent to one independent reading and then recording three consecutive individual readings. The three individual readings shall be averaged.

The deviation between the average readings at both flow rates shall be determined. The deviation shall meet the applicable performance criteria specified in [Table 1](#).

This test shall be repeated three times at the zero point and three times at the span point. If the AMS meets the performance criterion by a factor of two or more for the first test, then any subsequent repeats (of the three) may be omitted.

The individual readings, averages and the deviations as well as the maximum deviation shall be reported.

The operation of any fault status signal with respect to flow shall be tested at this time.

E.10 Sensitivity to electric voltage

The supply voltage to the AMS shall be varied, using an isolating transformer, in steps of 5 % from the nominal supply voltage to at least the upper and the lower limits specified by the manufacturer. The measured signals of the AMS at zero point and at span point shall be determined at each voltage by waiting the time equivalent to one independent reading and then recording three consecutive individual readings. The three individual readings shall be averaged.

NOTE After changes in voltage the AMS can need time to stabilize. The deviations between the average reading at each voltage and the average reading at the nominal supply voltage are determined.

The deviations shall meet the applicable performance criteria specified in [Table 1](#) for all voltages. This test shall be repeated three times at the zero point and three times at the span point. If the AMS meets the performance criterion by a factor of two or more for the first test, then any subsequent repeats (of the three) may be omitted.

The individual readings, averages and deviations at each voltage as well as the maximum deviation at zero point and at span point shall be reported.

E.11 Cross-sensitivity

The influence of potentially interfering substances also present in the flue gas shall be determined by admitting test gas mixtures to the input of the complete AMS (upstream of the test gas conditioner, where present). The gas mixtures shall be produced with a mixing system in which an interferent is added to the gases for zero point and span point. The mixing system shall be compliant with national standards and shall have a maximum expanded uncertainty of 1 %. Reference materials (e.g. gases) shall be traceable to national standards and shall have an expanded uncertainty no greater than 2 %.

Interferents and their concentrations are defined in relation to the measuring principle and the intended measurement objective. The interferents listed in [Table E.1](#) shall be examined. The interferents shall be admitted individually.

Test gas without interferent and then with the interferent shall be applied. The measured signals of the AMS shall be determined for each test gas by waiting the time equivalent to one independent reading and then recording three consecutive individual readings. The three individual readings shall be averaged.

The deviations between the average reading with and without the interferent present at the zero point and span point shall be determined for each interferent.

All positive deviations above 0,5 % of the span gas concentration shall be summed and all negative deviations below -0,5 % of the span gas concentration shall be summed at both the zero point and span point. The maximum of the absolute values of the four summations shall meet the performance criteria specified in [Table 1](#).

The individual readings, averages and deviations at zero point and span point and for all interferences as well as the maximum deviation shall be reported.

Table E.1 — Concentrations of interferences used during cross sensitivity tests

Interferent	Mass or volume concentration	
	Value	Unit
O ₂	3 ^a and 21	%
H ₂ O	30	%
CO	300	mg/m ³
CO ₂	15	%
CH ₄	50	mg/m ³
N ₂ O	20	mg/m ³
N ₂ O (fluidised-bed firing)	100	mg/m ³
NH ₃	20	mg/m ³
SO ₂	200	mg/m ³
SO ₂ (coal-fired power stations without desulphurisation)	1 000	mg/m ³
HCl	50	mg/m ³
HCl (coal-fired power stations)	200	mg/m ³

^a A test with 3 % oxygen concentration is used instead of a test without interferent.

E.12 Check of losses in the sampling line and conditioning system

E.12.1 Check of losses in the sampling line and conditioning system

The losses in the sampling line and conditioning system shall be checked by supplying zero gas and span gas to the analyser through the sampling system, as close as possible to the nozzle (in front of the filter if possible) and secondly direct to the analyser. Possible impurities in the entire system may lead to memory effects due to adsorption or desorption to or from the surfaces. Differences shall be less than 2 %.

The test gas should have an NO (NO₂) concentration of about 70 % to 80 % of the measuring range or level of NO₂ occurrence (when monitoring NO_x using NO₂/NO converter). In case of NO_x monitoring using NO₂/NO converter at NO₂ level exceeding 5 % of NO_x, differences for NO₂ shall be less than 20 %.

E.13 Check of leakage in the sampling line and conditioning system

The sampling system shall be checked for leaks. The procedure of leak test is as follows:

- assemble the complete sampling system, including charging the filter housing and absorbers;
- allow the sampler to warm up to its operating temperature;
- seal the nozzle inlet;
- close the nozzle and switch on the pump(s);
- after reaching minimum pressure read the flow rate.

E.14 Excursion of measurement beam of cross-stack in situ AMS

Gradually and precisely deflect the transmitter and then receiver assemblies of the AMS in the horizontal and vertical planes in a series of separate tests, and then record the measured signals using reference materials.

NOTE 1 This test typically applies to cross-stack in situ optical techniques. The test also applies to extractive AMS with separate transmitter and receiver assemblies. Extractive systems using an in situ analyser is securely mounted to an optical bench or rig and hence not subject to this.

NOTE 2 This testing requires calibration standards (e.g. reference filters) and an optical bench.

NOTE 3 Typically the experimental path length for this test can be from 1 m up to 5 m at least, although the test is performed at the maximum path length practical.

Deflections shall be carried out for both the position of the zero point and as well as for that of a span point for approx. 70 % to 90 % of the output range over two typical measurement path lengths. Initially one deflects the transmitter and records the data. Then resets its position and then one deflects the receiver and records the variation. These processes are repeated.

The range of deflection shall be equal to at least twice the angle specified by the manufacturer. It should also be tested as far as the deflection limit permitted by the assemblies - if necessary in larger increments.

The efficiency of any manual optical adjustment facilities shall be examined at least in qualitative terms. Automatic adjustment processes shall be activated and included in the test.

The measured signals obtained for the various test steps shall be included in tabular form in the test report. These measured signals shall be paired up with the deflection angles.

The maximum permissible deflection angles shall be stated within which the AMS satisfies the performance criterion. In the case of automatically aligning AMS, the manner of operation shall be described and verified by means of test results.

Annex F (informative)

Examples of results for the validation of NO_x AMS

F.1 NO and NO₂ (NO_x) measurement

The results of performance tests according to performance characteristics of [Annex E](#) for the NO and/or NO₂ measurement using cold-dry or hot-wet extractive methods (CL, NDIR, FTIR, NDUV) and in situ methods (DOAS) are given in [Tables F.1](#) to [F.4](#).

NOTE Most of the data listed in [Tables G.1](#) to [G.4](#) are referred to the results of the performance tests in Reference [\[8\]](#).

Table F.1 — Examples of performance test results for NO and/or NO₂ measurement by using cold-dry extractive chemiluminescence methods (CL)

Performance characteristic	Performance criterion	Cold-dry extractive		
		CL-1	CL-2	
Typical lowest range		NO 134 mg/m ³	NO 90 mg/m ³	NO _x 90 mg/m ³
Response time	≤ 200 s	56 s	140 s	140 s
Standard deviation of repeatability at zero point	≤ 2 % of the upper limit of the lowest measuring range used	0,0 %	0,18 %	0,20 %
Standard deviation of repeatability at span point	≤ 2 % of the upper limit of the lowest measuring range used	0,1 %	0,30 %	0,0 %
Lack-of-fit	≤ 2 % of the upper limit of the lowest measuring range used	0,82 %	0,70 %	0,80 %
Zero drift within the period of unattended operation	≤ 3 % of the upper limit of the lowest measuring range used	0,3 %	1,0 %	0,9 %
Span drift within the period of unattended operation	≤ 3 % of the upper limit of the lowest measuring range used	3,0 %	3,0 %	-2,7 %
Sensitivity to ambient temperature, for a change of 20 K in the temperature range specified by the manufacturer	≤ 5 % of the upper limit of the lowest measuring range used	-2,0 %	3,5 %	4,5 %
Sensitivity to sample gas pressure, for a pressure change of 3 kPa	≤ 2 % of the upper limit of the lowest measuring range used			
Sensitivity to sample gas flow for extractive AMS	≤ 2 % of the upper limit of the lowest measuring range used	-0,7 %	< 2,0 %	< 2,0 %
Sensitivity to electric voltage in the range -15 % below or +10 % above from the nominal voltage stated by the manufacturer	≤ 2 % of the upper limit of the lowest measuring range used	0,0 %	-0,30 %	0,40 %
Influence of vibration	≤ 2 % of the upper limit of the lowest measuring range used	—	—	—
Cross-sensitivity	≤ 4 % of the upper limit of the lowest measuring range used	3,81 %	-0,13 %	-2,7 %

Table F.1 (continued)

Performance characteristic	Performance criterion	Cold-dry extractive		
		CL-1	CL-2	
Excursion of the measurement beam of cross-stack in situ AMS	$\leq 2\%$ of the measured value of the lowest measuring range used	—	—	
NO ₂ /NO converter efficiency for NO _x AMS		100 %		96,9 %

Table F.2 — Examples of performance test results for NO and/or NO₂ measurement by using cold-dry extractive NDIR and NDUV methods

Performance characteristic	Performance criterion	Cold-dry extractive		
		NDIR	NDUV	
Typical lowest range		NO _x 100 mg/m ³	NO 33,5 mg/m ³	NO ₂ 125 mg/m ³
Response time	≤ 200 s	60 s	62 s	58 s
Standard deviation of repeatability at zero point	$\leq 2\%$ of the upper limit of the lowest measuring range used	0,1 %	0,05 %	0,04 %
Standard deviation of repeatability at span point	$\leq 2\%$ of the upper limit of the lowest measuring range used	0,2 %	0,07 %	0,13 %
Lack-of-fit	$\leq 2\%$ of the upper limit of the lowest measuring range used	0,30 %	0,20 %	0,92 %
Zero drift within 24 h	$\leq 2\%$ of the upper limit of the lowest measuring range used	0,12 %		
Span drift within 24 h	$\leq 2\%$ of the upper limit of the lowest measuring range used	-0,19 %		
Zero drift within the period of unattended operation	$\leq 3\%$ of the upper limit of the lowest measuring range used	0,94 %	0,8 %	-3,0 %
Span drift within the period of unattended operation	$\leq 3\%$ of the upper limit of the lowest measuring range used	-2,81 %	-1,6 %	-2,9 %
Sensitivity to ambient temperature, for a change of 20 K in the temperature range specified by the manufacturer	$\leq 5\%$ of the upper limit of the lowest measuring range used	1,9 %	0,91 %	-1,24 %
Sensitivity to sample gas pressure, for a pressure change of 3 kPa	$\leq 2\%$ of the upper limit of the lowest measuring range used			
Sensitivity to sample gas flow for extractive AMS	$\leq 2\%$ of the upper limit of the lowest measuring range used	0,4 %	0,21 %	-1,31 %
Sensitivity to electric voltage in the range -15 % below or +10 % above from the nominal voltage stated by the manufacturer	$\leq 2\%$ of the upper limit of the lowest measuring range used	-0,9 %	0,23 %	0,19 %
Cross-sensitivity	$\leq 4\%$ of the upper limit of the lowest measuring range used	3,00 %	1,35 %	1,96 %
Excursion of the measurement beam of cross-stack in situ AMS	$\leq 2\%$ of the measured value of the lowest measuring range used			
NO ₂ /NO converter efficiency for NO _x AMS		97,6 %		

Table F.3 — Examples of performance test results for NO and/or NO₂ measurement by using hot-wet extractive FTIR methods

Performance characteristic	Performance criterion	Hot-wet extractive	
		FTIR	
Typical lowest range		NO 150 mg/m ³	NO ₂ 80 mg/m ³
Response time	≤ 200 s	134 s	172 s
Standard deviation of repeatability at zero point	≤ 2 % of the upper limit of the lowest measuring range used	0,1 %	0,3 %
Standard deviation of repeatability at span point	≤ 2 % of the upper limit of the lowest measuring range used	0,1 %	1,4 %
Lack-of-fit	≤ 2 % of the upper limit of the lowest measuring range used	-0,27 %	0,10 %
Zero drift within the period of unattended operation	≤ 3 % of the upper limit of the lowest measuring range used	0,2 %	1,0 %
Span drift within the period of unattended operation	≤ 3 % of the upper limit of the lowest measuring range used	1,3 %	1,3 %
Sensitivity to ambient temperature, for a change of 20 K in the temperature range specified by the manufacturer	≤ 5 % of the upper limit of the lowest measuring range used	-0,4 %	-1,5 %
Sensitivity to sample gas pressure, for a pressure change of 3 kPa	≤ 2 % of the upper limit of the lowest measuring range used		
Sensitivity to sample gas flow for extractive AMS	≤ 2 % of the upper limit of the lowest measuring range used	-0,9 %	-1,4 %
Sensitivity to electric voltage in the range -15 % below or +10 % above from the nominal voltage stated by the manufacturer	≤ 2 % of the upper limit of the lowest measuring range used per 10 V	0,5 %	0,3 %
Cross-sensitivity	≤ 4 % of the upper limit of the lowest measuring range used	-1,67 %	2,95 %
Excursion of the measurement beam of cross-stack in situ AMS	≤ 2 % of the measured value of the lowest measuring range used		
NO ₂ /NO converter efficiency for NO _x AMS			

Table F.4 — Examples of performance test results for NO measurement by using in situ methods (DOAS)

Performance characteristic	Performance criterion	In situ	
		DOAS cross stack	DOAS point monitor
Typical lowest range		NO 70 mg/m ³	NO 70 mg/m ³
Response time	≤ 200 s	39 s	39 s
Standard deviation of repeatability at zero point	≤ 2 % of the upper limit of the lowest measuring range used	0,09 %	0,13 %
Standard deviation of repeatability at span point	≤ 2 % of the upper limit of the lowest measuring range used	0,32 %	0,22 %

Table F.4 (continued)

Performance characteristic	Performance criterion	In situ	
		DOAS cross stack	DOAS point monitor
Lack-of-fit	$\leq 2\%$ of the upper limit of the lowest measuring range used	-0,9 %	-0,9 %
Zero drift within the period of unattended operation	$\leq 3\%$ of the upper limit of the lowest measuring range used	0,9 %	0,4 %
Span drift within the period of unattended operation	$\leq 3\%$ of the upper limit of the lowest measuring range used	-2,3 %	1,6 %
Sensitivity to ambient temperature, for a change of 20 K in the temperature range specified by the manufacturer	$\leq 5\%$ of the upper limit of the lowest measuring range used	0,6 %	-0,6 %
Sensitivity to sample gas pressure, for a pressure change of 3 kPa	$\leq 2\%$ of the upper limit of the lowest measuring range used	-0,1 %	-0,1 %
Sensitivity to sample gas flow for extractive AMS	$\leq 2\%$ of the upper limit of the lowest measuring range used		
Sensitivity to electric voltage in the range -15 % below or +10 % above from the nominal voltage stated by the manufacturer	$\leq 2\%$ of the upper limit of the lowest measuring range used	0,3 %	0,3 %
Influence of vibration	$\leq 2\%$ of the upper limit of the lowest measuring range used	-0,9 %	-0,9 %
Cross-sensitivity	$\leq 4\%$ of the upper limit of the lowest measuring range used	3,6 %	3,6 %
Excursion of the measurement beam of cross-stack in situ AMS	$\leq 2\%$ of the measured value of the lowest measuring range used	-1,0 %	-1,0 %
NO ₂ /NO converter efficiency for NO _x AMS			

Annex G (informative)

Calculation of uncertainty of measurement of NO and/NO₂ or NO_x

G.1 General

The model equations in this clause, as well as calculations of partial uncertainties are related to the values measured by the analyser and expressed in mg/m³ (NO, NO₂ or NO_x). Explanation and calculation procedures for the standard uncertainty associated with measurement are given in ISO 20988.

G.2 Results of uncertainty calculation

The quantification of the impact of selected performance characteristics as partial standard uncertainty is calculated in accordance with ISO 14956.

Combined standard uncertainty ($u(\gamma_{\text{NO}})$) and expanded uncertainty ($U(\gamma_{\text{NO}})$) are calculated as follows:

$$u(\gamma_{\text{NO}}) = \sqrt{u_{r,0}^2 + u_{r,s}^2 + u_{\text{lof}}^2 + u_{d,0}^2 + u_{d,s}^2 + u_{\text{inf},p}^2 + u_{\text{inf},f}^2 + u_{\text{inf},T}^2 + u_{\text{inf},V}^2 + u_{i,\text{NO}}^2 + u_{\text{mb}}^2} \quad (\text{G.1})$$

$$U(\gamma_{\text{NO}}) = k \cdot u(\gamma_{\text{NO}}) = 1,96u(\gamma_{\text{NO}}) \quad (\text{G.2})$$

k : coverage factor (=1,96)

Table G.1 — Examples of performance test results for NO and/or NO₂ measurement by using cold-dry extractive methods (CL)

Performance characteristic	Partial standard uncertainty	Value of standard uncertainty at upper limit of the lowest measuring range used (mg/m ³)		
		CL-1	CL-2	
Lowest range		NO 0-134 mg/m ³	NO 0 - 90 mg/m ³	NO _x 0-90 mg/m ³
Standard deviation of repeatability at zero point	$u_{r,0}$	0,0 % × 134 = 0,0	0,18 % × 90 = 0,16	0,20 % × 90 = 0,18
Standard deviation of repeatability at span point	$u_{r,s}$	0,1 % × 134 = 0,13	0,30 % × 90 = 0,27	0,0 % × 90 = 0,0
Lack-of-fit	u_{lof}	$\frac{0,82 \% \times 134}{\sqrt{3}} = 0,63$	$\frac{0,70 \% \times 90}{\sqrt{3}} = 0,36$	$\frac{0,80 \% \times 90}{\sqrt{3}} = 0,42$
Zero drift within the period of unattended operation	$u_{d,0}$	$\frac{0,30 \% \times 134}{\sqrt{3}} = 0,23$	$\frac{1,0 \% \times 90}{\sqrt{3}} = 0,52$	$\frac{0,90 \% \times 90}{\sqrt{3}} = 0,47$
Span drift within the period of unattended operation	$u_{d,s}$	$\frac{3,0 \% \times 134}{\sqrt{3}} = 2,3$	$\frac{3,0 \% \times 90}{\sqrt{3}} = 1,6$	$\frac{-2,7\% \times 90}{\sqrt{3}} = 1,4$
Sensitivity to ambient temperature, for a change of 20 K in the temperature range specified by the manufacturer	$u_{\text{inf},T}$	$\frac{-2,0 \% \times 134}{\sqrt{3}} = 1,5$	$\frac{3,5 \% \times 90}{\sqrt{3}} = 1,8$	$\frac{4,5 \% \times 90}{\sqrt{3}} = 2,3$

Table G.1 (continued)

Performance characteristic	Partial standard uncertainty	Value of standard uncertainty at upper limit of the lowest measuring range used (mg/m ³)		
		CL-1	CL-2	
Sensitivity to sample gas pressure, for a pressure change of 3 kPa	$u_{inf,p}$			
Sensitivity to sample gas flow for extractive AMS	$u_{inf,f}$	$\frac{0,70 \% \times 134}{\sqrt{3}} = 0,54$	$\frac{2,0 \% \times 90}{\sqrt{3}} = 1,0$	$\frac{2,0 \% \times 90}{\sqrt{3}} = 1,0$
Sensitivity to electric voltage in the range -15 % below or +10 % above from the nominal voltage stated by the manufacturer	$u_{inf,v}$	$\frac{0,0 \% \times 134}{\sqrt{3}} = 0,0$	$\frac{-0,3 \% \times 90}{\sqrt{3}} = 0,16$	$\frac{0,4 \% \times 90}{\sqrt{3}} = 0,20$
Cross-sensitivity	$u_{i,NO}$	$\frac{3,81 \% \times 134}{\sqrt{3}} = 2,9$	$\frac{0,13 \% \times 90}{\sqrt{3}} = 0,07$	$\frac{-2,7 \% \times 90}{\sqrt{3}} = 1,4$
Excursion of the measurement beam of cross-stack in situ AMS	u_{mb}			
NO ₂ /NO converter efficiency for NO _x AMS	u_{ce}	0		$\frac{(1-0,97) \times 90}{\sqrt{3}} = 1,6$

G.2.1 Chemiluminescence type AMS

G.2.1.1 CL-1

NO

The combined uncertainty, $u(\gamma_{NO})$ is calculated using [Formula \(G.1\)](#) and the value of each partial standard uncertainty listed in [Table G.1](#) as an example:

$$u(\gamma_{NO}) = \sqrt{0,0^2 + 0,13^2 + 0,63^2 + 0,23^2 + 2,3^2 + 1,5^2 + 0,54^2 + 0,0^2 + 2,9^2}$$

$$= \sqrt{16,9} = 4,1 \text{ mg/m}^3$$

The expanded uncertainty ($U(\gamma_{NO})$) is thus calculated as $1,96 \times 4,1 = 8,0 \text{ mg/m}^3$ (6,0 % of the range).

G.2.1.2 CL-2

NO

Based on the data listed in the 4th column of [Table G.1](#), the combined uncertainty at upper limit of the lowest measuring range of 90 mg/m³ is estimated 2,71 mg/m³.

The expanded uncertainty ($U(\gamma_{NO})$) is thus calculated as 5,3 mg/m³ (5,9 % of the range).

NO_x

Based on the data listed in the 5th column of [Table G.1](#), the combined uncertainty at upper limit of the lowest measuring range of 90 mg/m³ is estimated 3,63 mg/m³.

The expanded uncertainty ($U(\gamma_{NOx})$) is thus calculated as 7,1 mg/m³ (7,9 % of the range).

Table G.2 — Examples of performance test results for NO and/or NO₂ measurement by using cold-dry extractive methods (NDIR and NDUV)

Performance characteristic	Partial standard uncertainty	Value of standard uncertainty at upper limit of the lowest measuring range used (mg/m ³)		
		NDIR	NDUV	
Typical lowest range		NO _x 100mg/m ³	NO 33,5 mg/m ³	NO ₂ 125 mg/m ³
Standard deviation of repeatability at zero point	$u_{r,0}$	0,1 %×100 = 0,1	0,05 %×33,5 = 0,02	0,04 %×125 = 0,05
Standard deviation of repeatability at span point	$u_{r,s}$	0,2 %×100 = 0,2	0,07 %×33,5 = 0,02	0,13 %×125 = 0,16
Lack-of-fit	u_{lof}	$\frac{0,3 \% \times 100}{\sqrt{3}} = 0,17$	$\frac{0,2 \% \times 33,5}{\sqrt{3}} = 0,04$	$\frac{0,92 \% \times 125}{\sqrt{3}} = 0,66$
Zero drift within 24 h	$u_{d,o}$	$\frac{0,12 \% \times 100}{\sqrt{3}} = 0,07$		
Span drift within 24 h	$u_{d,s}$	$\frac{0,19 \% \times 100}{\sqrt{3}} = 0,11$		
Zero drift within the period of unattended operation	$u_{d,o}$	$\frac{0,94 \% \times 100}{\sqrt{3}} = 0,54$	$\frac{0,8 \% \times 33,5}{\sqrt{3}} = 0,15$	$\frac{3,0 \% \times 125}{\sqrt{3}} = 2,2$
Span drift within the period of unattended operation	$u_{d,s}$	$\frac{2,81 \% \times 100}{\sqrt{3}} = 1,6$	$\frac{1,6 \% \times 33,5}{\sqrt{3}} = 0,30$	$\frac{2,9 \% \times 125}{\sqrt{3}} = 2,1$
Sensitivity to ambient temperature, for a change of 20 K in the temperature range specified by the manufacturer	$u_{inf,T}$	$\frac{1,9 \% \times 100}{\sqrt{3}} = 1,1$	$\frac{0,91 \% \times 33,5}{\sqrt{3}} = 0,18$	$\frac{1,24 \% \times 125}{\sqrt{3}} = 0,90$
Sensitivity to sample gas pressure, for a pressure change of 3 kPa	$u_{inf,p}$			
Sensitivity to sample gas flow for extractive AMS	$u_{inf,f}$	$\frac{0,4 \% \times 100}{\sqrt{3}} = 0,23$	$\frac{0,21 \% \times 33,5}{\sqrt{3}} = 0,04$	$\frac{1,31 \% \times 125}{\sqrt{3}} = 0,95$
Sensitivity to electric voltage in the voltage range specified by the manufacturer	$u_{inf,V}$	$\frac{-0,9 \% \times 100}{\sqrt{3}} = 0,53$	$\frac{0,23 \% \times 33,5}{\sqrt{3}} = 0,04$	$\frac{0,19 \% \times 125}{\sqrt{3}} = 0,14$
Cross-sensitivity	$u_{i,NO}$	$\frac{3,0 \% \times 100}{\sqrt{3}} = 1,7$	$\frac{1,35 \% \times 33,5}{\sqrt{3}} = 0,26$	$\frac{1,96 \% \times 125}{\sqrt{3}} = 1,4$
Excursion of the measurement beam of cross-stack in situ AMS	u_{mb}			
NO ₂ /NO converter efficiency for NO _x AMS	u_{ce}	$\frac{0,05(1-0,98)\% \times 100}{\sqrt{3}} = 0,06$		

G.2.2 NDIR type AMS

G.2.2.1 NO_x

Based on the data listed in the third column of [Table G.2](#), the combined uncertainty at upper limit of the lowest measuring range of 100 mg/m³ is estimated 2,70 mg/m³.

The expanded uncertainty ($U(\gamma_{NO_x})$) is thus calculated as 5,3 mg/m³ (5,3 % of the range).

G.2.3 NDUV type AMS

G.2.3.1 NO

Based on the data listed in the 4th column of [Table G.2](#), the combined uncertainty at upper limit of the lowest measuring range of 33,5 mg/m³ is estimated 0,47mg/m³.

The expanded uncertainty ($U(\gamma_{NO})$) is thus calculated as 0,92 mg/m³ (2,7 % of the range).

G.2.3.2 NO₂

Based on the data listed in the 5th column of [Table G.2](#), the combined uncertainty at upper limit of the lowest measuring range of 125 mg/m³ is estimated 3,69 mg/m³.

The expanded uncertainty ($U(\gamma_{NO_2})$) is thus calculated as 7,2 mg/m³ (5,8 % of the range).

Table G.3 — Examples of performance test results for NO and/or NO₂ measurement by using hot-wet extractive methods (FTIR)

Performance characteristic	Partial standard uncertainty	Value of standard uncertainty at upper limit of the lowest measuring range used (mg/m ³)	
		FTIR	
Typical lowest range		NO 150 mg/m ³	NO ₂ 80 mg/m ³
Standard deviation of repeatability at zero point	$u_{r,0}$	0,1 % × 150 = 0,15	0,3 % × 80 = 0,24
Standard deviation of repeatability at span point	$u_{r,s}$	0,1 % × 150 = 0,15	1,4 % × 80 = 1,1
Lack-of-fit	u_{lof}	$\frac{0,27 \% \times 150}{\sqrt{3}} = 0,23$	$\frac{0,10 \% \times 80}{\sqrt{3}} = 0,05$
Zero drift within the period of unattended operation	$u_{d,o}$	$\frac{0,2 \% \times 150}{\sqrt{3}} = 0,17$	$\frac{1,0 \% \times 80}{\sqrt{3}} = 0,46$
Span drift within the period of unattended operation	$u_{d,s}$	$\frac{1,3 \% \times 150}{\sqrt{3}} = 1,1$	$\frac{1,3 \% \times 80}{\sqrt{3}} = 0,60$
Sensitivity to ambient temperature, for a change of 20 K in the temperature range specified by the manufacturer	$u_{inf,T}$	$\frac{-0,4 \% \times 150}{\sqrt{3}} = 0,35$	$\frac{-1,5 \% \times 80}{\sqrt{3}} = 0,69$
Sensitivity to sample gas pressure, for a pressure change of 3 kPa	$u_{inf,p}$		
Sensitivity to sample gas flow for extractive AMS	$u_{inf,f}$	$\frac{-0,9 \% \times 150}{\sqrt{3}} = 0,78$	$\frac{-1,4 \% \times 80}{\sqrt{3}} = 0,65$

Table G.3 (continued)

Performance characteristic	Partial standard uncertainty	Value of standard uncertainty at upper limit of the lowest measuring range used (mg/m ³)	
		FTIR	
Sensitivity to electric voltage in the voltage range specified by the manufacturer	$u_{\text{inf},V}$	$\frac{0,5 \% \times 150}{\sqrt{3}} = 0,43$	$\frac{0,3 \% \times 80}{\sqrt{3}} = 0,14$
Cross-sensitivity	$u_{i,\text{NO}}$	$\frac{-1,67 \% \times 150}{\sqrt{3}} = 1,4$	$\frac{2,10 \% \times 80}{\sqrt{3}} = 0,97$
Excursion of the measurement beam of cross-stack in situ AMS	u_{mb}		
NO ₂ /NO converter efficiency for NO _x AMS	u_{ce}		

G.2.4 FTIR type AMS

G.2.4.1 NO

Based on the data listed in the third column of Table G.3, the combined uncertainty at upper limit of the lowest measuring range of 150 mg/m³ is estimated 2,05 mg/m³.

The expanded uncertainty ($U(\gamma_{\text{NO}})$) is thus calculated as 4,0 mg/m³ (2,7 % of the range).

G.2.4.2 NO₂

Based on the data listed in the 4th column of Table G.3, the combined uncertainty at upper limit of the lowest measuring range of 80 mg/m³ is estimated 1,93 mg/m³.

The expanded uncertainty ($U(\gamma_{\text{NO}_2})$) is thus calculated as 3,8 mg/m³ (4,7 % of the range).

Table G.4 — Examples of performance test results for NO measurement by using in situ DOAS methods

Performance characteristic	Partial standard uncertainty	Value of standard uncertainty at upper limit of the lowest measuring range used (mg/m ³)	
		DOAS Cross stack	DOAS Point monitor
Typical lowest range		NO 70 mg/m ³	NO 70 mg/m ³
Standard deviation of repeatability at zero point	$u_{r,0}$	$0,09 \% \times 70 = 0,06$	$0,13 \% \times 70 = 0,09$
Standard deviation of repeatability at span point	$u_{r,s}$	$0,32 \% \times 70 = 0,22$	$0,22 \% \times 70 = 0,15$
Lack-of-fit	u_{lof}	$\frac{-0,9 \% \times 70}{\sqrt{3}} = 0,36$	$\frac{-0,9 \% \times 70}{\sqrt{3}} = 0,36$
Zero drift within the period of unattended operation	$u_{d,0}$	$\frac{0,9 \% \times 70}{\sqrt{3}} = 0,36$	$\frac{0,40 \% \times 70}{\sqrt{3}} = 0,16$
Span drift within the period of unattended operation	$u_{d,s}$	$\frac{-2,3 \% \times 70}{\sqrt{3}} = 0,93$	$\frac{1,6 \% \times 70}{\sqrt{3}} = 0,64$

Table G.4 (continued)

Performance characteristic	Partial standard uncertainty	Value of standard uncertainty at upper limit of the lowest measuring range used (mg/m ³)	
		DOAS Cross stack	DOAS Point monitor
Sensitivity to ambient temperature, for a change of 20 K in the temperature range specified by the manufacturer	$u_{\text{inf},f}$	$\frac{0,6 \% \times 70}{\sqrt{3}} = 0,24$	$\frac{-0,6 \% \times 70}{\sqrt{3}} = 0,24$
Sensitivity to sample gas pressure, for a pressure change of 3 kPa	$u_{\text{inf},T}$	$\frac{-0,1 \% \times 70}{\sqrt{3}} = 0,04$	$\frac{-0,1 \% \times 70}{\sqrt{3}} = 0,04$
Sensitivity to sample gas flow for extractive AMS	$u_{\text{inf},p}$		
Sensitivity to electric voltage in the voltage range specified by the manufacturer	$u_{\text{inf},V}$	$\frac{0,3 \% \times 70}{\sqrt{3}} = 0,12$	$\frac{0,3 \% \times 70}{\sqrt{3}} = 0,12$
Influence of vibration	u_{vib}	$\frac{-0,9 \% \times 70}{\sqrt{3}} = 0,36$	$\frac{0,3 \% \times 70}{\sqrt{3}} = 0,12$
Cross-sensitivity	$u_{i,\text{NO}}$	$\frac{3,6 \% \times 70}{\sqrt{3}} = 1,46$	$\frac{3,6 \% \times 70}{\sqrt{3}} = 1,46$
Excursion of the measurement beam of cross-stack in situ AMS	u_{mb}	$\frac{-0,62 \% \times 70}{\sqrt{3}} = 0,40$	$\frac{-1,0 \% \times 70}{\sqrt{3}} = 0,40$

G.2.5 In situ DOAS AMS

G.2.5.1 Cross stack type

Based on the data listed in the fourth column of [Table G.4](#), the combined uncertainty at upper limit of the lowest measuring range of 70 mg/m³ is estimated 1,90 mg/m³.

The expanded uncertainty ($U(\gamma_{\text{NO}})$) is thus calculated as 3,7 mg/m³ (5,3 % of the range).

G.2.5.2 Point monitor type

Based on the data listed in the third column of [Table G.4](#), the combined uncertainty at upper limit of the lowest measuring range of 70 mg/m³ is estimated 1,73 mg/m³.

The expanded uncertainty ($U(\gamma_{\text{NO}})$) is thus calculated as 3,4 mg/m³ (4,8 % of the range).

Bibliography

- [1] ISO 12039:2019, *Stationary source emissions — Determination of the mass concentration of carbon monoxide, carbon dioxide and oxygen in flue gas — Performance characteristics of automated measuring systems*
- [2] ISO/IEC Guide 98-3:2008, *Uncertainty of measurement — Part 3: Guide to the expression of uncertainty in measurement (GUM:1995)*
- [3] ISO 14385-1:2014, *Stationary source emissions — Greenhouse gases — Part 1: Calibration of automated measuring systems*
- [4] ISO 10396, *Stationary source emissions — Sampling for the automated determination of gas emission concentrations for permanently-installed monitoring systems*
- [5] ISO 14385-2:2014, *Stationary source emissions — Greenhouse gases — Part 2: Ongoing quality control of automated measuring systems*
- [6] ISO 20988, *Air quality — Guidelines for estimating measurement uncertainty*
- [7] ISO 7996:1985, *Ambient air — Determination of the mass concentration of nitrogen oxides — Chemiluminescence method*
- [8] The references are TÜV: www.gal1.de/en/index.htm MCERTS: www.csagroupuk.org/services/mcerts/mcerts-product-certification/mcerts-certified-products/

FOR BIS USE ONLY