International Standard



7996

INTERNATIONAL ORGANIZATION FOR STANDARDIZATION • МЕЖДУНАРОДНАЯ ОРГАНИЗАЦИЯ ПО СТАНДАРТИЗАЦИИ • ORGANISATION INTERNATIONALE DE NORMALISATION

Ambient air — Determination of the mass concentration of nitrogen oxides — Chemiluminescence method

Air ambiant — Détermination de la concentration en masse des oxydes d'azote — Méthode par chimiluminescence

First edition — 1985-12-15

FOR BIS USE ONLY

UDC 614.71 : 543.272.32

Ref. No. ISO 7996-1985 (E)

Descriptors: air, quality, chemical analysis, determination of content, nitrogen oxides.

Foreword

ISO (the International Organization for Standardization) is a worldwide federation of national standards bodies (ISO member bodies). The work of preparing International Standards is normally carried out through ISO technical committees. Each member body interested in a subject for which a technical committee has been established has the right to be represented on that committee. International organizations, governmental and non-governmental, in liaison with ISO, also take part in the work.

Draft International Standards adopted by the technical committees are circulated to the member bodies for approval before their acceptance as International Standards by the ISO Council. They are approved in accordance with ISO procedures requiring at least 75 % approval by the member bodies voting.

International Standard ISO 7996 was prepared by Technical Committee ISO/TC 146, *Air quality*.

Users should note that all International Standards undergo revision from time to time and that any reference made herein to any other International Standard implies its latest edition, unless otherwise stated.

FOR BIS USE ONLY

Ambient air — Determination of the mass concentration of nitrogen oxides — Chemiluminescence method

1 Scope and field of application

This International Standard specifies a chemiluminescence method for the determination of the mass concentration of nitrogen oxides present in ambient air.

The method is applicable to the determination of the mass concentration of nitrogen monoxide present in ambient air up to approximately 12,5 mg/m³ and of nitrogen dioxide up to approximately 19 mg/m³ respectively¹⁾ at 25 °C and 101,3 kPa.

For interferences, see 6.6.

2 References

ISO 6142, *Gas analysis — Preparation of calibration gas mixtures — Weighing methods.*

ISO 6144, *Gas analysis — Preparation of calibration gas mixtures — Static volumetric methods.*

ISO 6349, *Gas analysis — Preparation of calibration gas mixtures — Permeation method.*

ISO 6711, *Gas analysis — Checking of calibration gas mixtures by a comparison method.*

3 Principle

Passage of the air sample through a filter (to prevent mal-operation of the chemiluminescence analyser) at a constant flow rate into the reaction chamber of the analyser, where it is mixed with an excess of ozone. Filtering of the emitted radiation, proportional to the amount of nitrogen monoxide present in the air sample, by means of a selective optical filter and conversion of the filtered radiation into an electric signal by a photomultiplier tube.

Measurement of nitrogen dioxide in the air sample by reducing it to nitrogen monoxide by passage through a converter before it enters the reaction chamber.

The electric signal obtained is proportional to the total amount of nitrogen oxides, and the nitrogen dioxide contribution is calculated from the difference between this value and that obtained for nitrogen monoxide only — when the air sample does not pass through the converter.

Analysers may be of the dual or cyclic type. In the dual type, the air flow is divided into two streams, one passing directly to the reaction chamber and the other via the converter. There are two reaction chambers and one or two detectors respectively monitoring the nitrogen monoxide and nitrogen oxides content of the air sample. In the cyclic type analyser, there is only one reaction chamber and detector and the output alternates between nitrogen monoxide and total nitrogen oxides measurements, i.e. the air sample alternately bypasses or passes through the converter.

4 Reactions

Luminescence is a characteristic of many substances from which light is emitted when they are excited. This phenomenon is called chemiluminescence when produced as a result of a chemical reaction.

This chemiluminescence method is based on the reaction

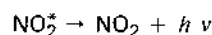
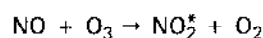

Excited nitrogen dioxide emits radiation centred around the near infra-red (1 200 nm).

5 Apparatus

Schematic diagrams of typical analysers are given in figures 1a) and 1b) (dual type) and figure 1c) (cyclic type). An apparatus consists of the following principal components (5.1 to 5.10).

1) At the temperature and pressure given, the following conversion factors apply.

$$\begin{aligned} \text{NO: } 1 \text{ mg/m}^3 &\cong 0,81 \text{ ppm (V/V)} \\ 1 \text{ ppm (V/V)} &\cong 1,23 \text{ mg/m}^3 \end{aligned}$$

$$\begin{aligned} \text{NO}_2: 1 \text{ mg/m}^3 &\cong 0,53 \text{ ppm (V/V)} \\ 1 \text{ ppm (V/V)} &\cong 1,88 \text{ mg/m}^3 \end{aligned}$$

5.1 Sample line.

The sample intake shall consist of a small inverted funnel connected to the sample line — the latter being as short as practically possible. Both shall be made of material which is inert to nitrogen monoxide and nitrogen dioxide. It is very important not to use any materials made from copper based alloys. From experience, the best materials to use are polytetrafluoroethylene (PTFE) or perfluoro(ethylene/propylene) (FEP). In order to avoid disturbance of the nitrogen monoxide-nitrogen dioxide-ozone equilibrium caused by reduced daylight intensity in the sample line, the residence time in the sample line should be as short as possible. The sample line may be moderately heated to avoid any condensation.

5.2 Particle filter.

The particle filter shall retain all particles likely to alter the performance of the analyser. At the same time, it and its support shall be made from material which will not retain nitrogen monoxide or nitrogen dioxide, for example PTFE or stainless steel. The particle filter shall be replaced or cleaned periodically as required by the dust loading at the sampling site. Overloading of this filter may cause loss of nitrogen dioxide by sorption on the particulate matter.

5.3 Control and regulation of sample flow rate.

The sample flow rate shall be maintained to $\pm 2\%$ of the specified by the manufacturer of the analyser. Flow rate control is usually maintained by a controlled pressure drop across restrictors.

5.4 Converter.

The converter shall consist of a heated furnace maintained at a constant temperature and is made of stainless steel, copper, molybdenum, tungsten or spectroscopically pure carbon. It shall be capable of converting at least 95 % of the nitrogen dioxide to nitrogen monoxide at a temperature not exceeding 400 °C.

The role of the converter is very important since it controls the determination of nitrogen dioxide.

5.5 Ozone generator.

Ozone is generated from oxygen by either ultra-violet radiation or by a high voltage silent electric discharge. If oxygen in ambient air is used for ozone generation by a high voltage silent electric discharge, it is essential that the air be thoroughly dried and filtered before entering the generator. If the ozone is generated using oxygen of recognized analytical grade from a compressed gas cylinder, this oxygen can be fed directly into the generator. The concentration of ozone produced shall be greater than the maximum concentration of nitrogen oxides being measured.

The flow rate of air or oxygen to the ozone generator shall be kept constant.

5.6 Reaction chamber.

This shall be constructed of an inert material. Its dimensions determine the characteristics of the chemiluminescence reaction (residence time, speed of reaction). The reaction chamber may be heated slightly to avoid condensation. The reaction is generally carried out at reduced pressure to minimize quenching effects and increase sensitivity.

5.7 Optical filter.

This filter shall remove all radiation at wavelengths below 600 nm, thus avoiding any interference produced by the chemiluminescence reaction with unsaturated hydrocarbons which radiate at these wavelengths.

5.8 Photomultiplier tube.

The output of the analyser is closely affected by the characteristics of the photomultiplier tube. In order to reduce background noise and the effect of temperature changes, the tube is usually housed in a thermostatically controlled refrigerated container.

5.9 Ozone filter.

The ozone shall be removed from the gas on leaving the reaction chamber by passage through activated charcoal. This prevents pollution of the immediate ambient air and protects the sampling pump.

5.10 Sampling pump.

Situated at the end of the circuit, the sampling pump draws air through the apparatus. It shall be capable of operating under the pressure conditions required for the reaction chamber.

5.11 Apparatus for checking the analyser converter efficiency (see 6.1).

5.11.1 Source of nitrogen monoxide, compressed gas cylinder containing nitrogen monoxide in nitrogen at a concentration of the order of 1 ppm (V/V). The actual concentration need not be known provided that it remains constant throughout the test.

5.11.2 Source of oxygen, compressed gas cylinder containing oxygen or air.

5.11.3 Ultra-violet lamp, capable of varying the size of the lamp window for producing varying amounts of ozone from oxygen.

5.11.4 Chemiluminescence analyser in which the temperature of the converter furnace is controllable.

6 Procedure

The operation of the apparatus will vary from one to another. Follow the manufacturer's instructions regarding setting up operations, and flow rates of air sample and ozone. The frequency of calibration will vary from one apparatus to another, but this should be carried out as frequently as is practically possible.

6.1 Converter efficiency

One of the most important components of the apparatus (5.2 to 5.10) is the converter, which reduces nitrogen dioxide to nitrogen monoxide, and permits, by difference, the measurement of the nitrogen dioxide concentration.

Before calibrating the analyser, it is essential to ensure that the converter efficiency lies as close to unity as possible. The determination of the efficiency is based on the principle that the response of the apparatus to the total amount of nitrogen oxides (NO_x) does not change if analyses are made of varying mixtures of nitrogen monoxide and nitrogen dioxide, but for which the total concentration of nitrogen oxides is constant.

A schematic diagram of a suitable arrangement is given in figure 2 (see also 5.11).

Ensure that the total flow rate of nitrogen monoxide and oxygen (or air) is greater than the flow rate of gas through the analyser — the excess being led away as shown in figure 2.

In each of the following steps, note both the nitrogen monoxide and total nitrogen oxides concentration responses of the analyser. This then checks the level of nitrogen dioxide being produced which should be in the range 90 to 99 % of the total nitrogen oxides level.

a) With the ultra-violet lamp extinguished, note the total nitrogen oxides concentration response, R_1 , and the nitrogen monoxide concentration response, P_1 .

b) Switch on the ultra-violet lamp. Ozone is formed which reacts with the nitrogen monoxide to produce nitrogen dioxide before the gases enter the analyser. Note the total nitrogen oxides concentration response, R_2 , and the nitrogen monoxide concentration response, P_2 .

c) Vary the output of the ultra-violet lamp, and note the total nitrogen oxides concentration responses (R_3, R_4, R_5 , etc.) and the nitrogen monoxide concentration responses (P_3, P_4, P_5 , etc.). The ratios $R_2/R_1, R_3/R_1, R_4/R_1$, etc. should be as close to unity as possible (within the range of repeatability of the analyser), i.e. the total nitrogen oxides concentration response should be constant in each instance and independent of the ratio of the concentrations of nitrogen dioxide to nitrogen monoxide.

d) Determine the actual efficiency, expressed as a percentage, of the converter from the formula

$$\frac{(R_n - P_n) - (R_1 - P_1)}{P_1 - P_n} \times 100$$

where R_n and P_n are the total nitrogen oxides and nitrogen monoxide concentration responses respectively for each position of the window of the ultra-violet lamp.

If this efficiency falls below 95 %, replace or regenerate the converter.

6.2 Calibration of the chemiluminescence analyser

6.2.1 Principle

Generation of calibration gas mixtures containing accurately known concentrations of nitrogen dioxide by means of a permeation system (see ISO 6349). Dilution of the nitrogen dioxide emitted with zero air of a relative humidity of about 50 % to obtain nitrogen dioxide concentrations suitable for the calibration of the nitrogen dioxide and total nitrogen oxides channels. Calibration of the nitrogen monoxide channel by using the same system in conjunction with a converter, the efficiency of which has been determined as in 6.1.

6.2.2 Apparatus

A typical system for generating the required concentrations of nitrogen monoxide and nitrogen dioxide is shown in figure 3.

6.2.2.1 Air flow rate controllers and flow meters, capable of maintaining and measuring flow rates to ± 1 %.

6.2.2.2 Drier, to remove moisture from the air passing over the permeation cell. Satisfactory driers are permeation driers or suitable large tubes of desiccants containing silica gel or similar.

6.2.2.3 Constant temperature chamber, capable of housing the nitrogen dioxide permeation cell and maintaining its temperature to within ± 1 °C. It shall incorporate a temperature measuring device having an accuracy of $\pm 0,05$ °C.

6.2.2.4 Valves. Two valves — one to direct the nitrogen monoxide (or nitrogen dioxide) flow into the diluent zero air flow and one to allow the nitrogen dioxide to flow through or bypass the converter.

6.2.2.5 Output manifold, of an inert material and of sufficient diameter to ensure an insignificant pressure drop at the analyser connection. The system shall have a vent designed to ensure sufficient pressure within the manifold and so prevent ambient air from entering it.

6.2.3 Procedure

Assemble the apparatus as shown in figure 3. Select the operating range of the analyser to be calibrated. In order to obtain maximum precision and accuracy for the nitrogen dioxide calibration, all channels shall be set to the same range. Switch the valve to vent the flow from the permeation cell and adjust the diluent air flow rate to provide zero air at the output manifold. For highest accuracy it is necessary to zero the analyser with the ozone flowing. This is best achieved by using

a "pre-reactor" vessel — one which has a volume of 2 to 3 times that of the reaction chamber. The ozone reacts with any nitrogen monoxide present in the pre-reactor, ensuring that no nitrogen monoxide reaches the reaction chamber. At the same time, this technique maintains ozone in the reaction chamber in the same concentration as during normal ambient air measurements. Thus, a true zero air is generated and the artificial signal caused by reaction of ozone with the reaction chamber surface is eliminated. When the responses of the analyser have stabilized, adjust the analyser zero control(s).

6.3 Preparation of calibration graph

6.3.1 Nitrogen monoxide

Switch the 3-way valve [(1) in figure 3] so that nitrogen dioxide from the permeation cell passes through the converter. Switch the second valve [(2) in figure 3] to provide nitrogen monoxide at the output manifold. Adjust the zero air flow to generate approximately 80 % of the upper limit of the nitrogen monoxide range.

The actual nitrogen monoxide concentration, $\varphi(\text{NO})$, expressed in parts per million by volume, is given by the equation

$$\varphi(\text{NO}) = \frac{q_m K}{q_{V1} + q_{V2}} \quad \dots (1)$$

where

q_m is the permeation rate, expressed in micrograms per minute, of nitrogen dioxide;

K is the volume conversion factor (0,532 $\mu\text{l}/\mu\text{g}$ at 25 °C and 101,3 kPa) for nitrogen dioxide;

q_{V1} is the volume flow rate, expressed in litres per minute, of zero air across the permeation cell;

q_{V2} is the volume flow rate, expressed in litres per minute, of the diluent air.

NOTE — The mass concentration of nitrogen monoxide, $\varrho(\text{NO})$, expressed in micrograms per cubic metre, is given by the equation

$$\varrho(\text{NO}) = \frac{q_m \times 10^3 \times 1,23}{q_{V1} + q_{V2}} \quad \dots (2)$$

After stabilization, adjust the nitrogen monoxide span control to obtain a response on the percentage scale of

$$\% \text{ span} = \frac{\varphi(\text{NO}) \times 100}{L} + \varphi'(\text{NO}) \quad \dots (3)$$

where

L is the range limit;

$\varphi'(\text{NO})$ is the nitrogen monoxide concentration, expressed in parts per million by volume, in the diluent air.

Generate several additional concentrations (at least five spaced evenly over the range) by suitable adjustment of $(q_{V1} + q_{V2})$. For each setting, calculate the exact nitrogen monoxide concentration and record the response of the analyser. Plot the

responses against respective concentrations to obtain a calibration graph. Subsequent calibration can be checked with a two-point calibration — a zero point and one at a concentration of about 80 % full scale.

6.3.2 Nitrogen dioxide and total nitrogen oxides

Switch the 3-way valve [(1) in figure 3] to bypass the converter and to provide nitrogen dioxide at the output manifold. Adjust the zero air flow rate to generate a nitrogen dioxide concentration of approximately 80 % of the upper limit of the nitrogen dioxide range. The actual concentration of nitrogen dioxide or total nitrogen oxides is calculated as in equation (1) or (3) — $\varphi(\text{NO})$ being substituted by $\varphi(\text{NO}_2)$ or $\varphi(\text{NO}_x)$ and $\varphi'(\text{NO})$ by $\varphi'(\text{NO}_2)$ or $\varphi'(\text{NO}_x)$.

Record the nitrogen dioxide and total nitrogen oxides concentrations and the corresponding response of the analyser. Adjust q_{V2} to obtain at least five different concentrations of nitrogen dioxide (or nitrogen oxides) evenly spaced over the range. Record the corresponding response and plot this against the calculated concentrations to obtain the calibration graph — allowance shall be made for any nitrogen dioxide (or nitrogen oxides) in the diluent air. When analysing mixtures of nitrogen monoxide and nitrogen dioxide, check that the total nitrogen oxides response is the same as the sum of the responses due to nitrogen monoxide and nitrogen dioxide.

NOTES

1 The mass concentration of nitrogen dioxide, $\varrho(\text{NO}_2)$, expressed in micrograms per cubic metre, is given by the equation

$$\varrho(\text{NO}_2) = \frac{q_m \times 10^3 \times K \times 1,88}{q_{V1} + q_{V2}} \quad \dots (4)$$

2 In the case of an analyser with only one adjuster for calibration, the latter can be fixed in a single operation directly using a nitrogen dioxide permeation system. It is useful to check that the response of the analyser is the same when it is presented with a sample of nitrogen monoxide of the same concentration.

3 Other calibration systems may be used:

- The use of compressed gas cylinders containing known concentrations of nitrogen oxides. Depending on the concentration present, these can be used directly or after suitable dilution, i.e. the mixture should be prepared according to ISO 6142 or ISO 6144 and checked for stability according to ISO 6711.
- Gas phase titration of a nitrogen monoxide standard using a calibrated source of ozone.

This shall be used with care and only after being shown to be equivalent to the standard method using the permeation cell.

6.4 Sampling

Take the air sample via the sample line as described in 5.1.

6.5 Determination

With the analyser connected to a suitable recorder or data logger/computer, take readings for nitrogen monoxide, total nitrogen oxides, and nitrogen dioxide.

6.6 Interferents

The determination of nitrogen oxides can be affected because, at high temperatures, the converter will also convert nitrogen compounds other than nitrogen dioxide to nitrogen monoxide partially or completely, depending on converter type and temperature. The most important of these are ammonia, amines, nitric acid, some organic and inorganic nitrites and nitrates, and peroxyacetylnitrate (PAN).

The determination may also be affected by poisoning of the catalyst in the converter by sulfur compounds and carbonyls.

The determination may be affected by variations of quenching effects originating from either pressure variation or water vapour in the reaction chamber. Generally the reaction takes place under reduced pressure to minimize these effects.

7 Expression of results

The readings (6.5) are converted to concentrations using the appropriate calibration graph and the results expressed in micrograms per cubic metre, or parts per million by volume,¹⁾ at 25 °C and 101,3 kPa.

8 Test report

The test report shall contain at least the following information :

- a) a complete identification of the air sample ;
- b) a reference to this International Standard ;
- c) the results ;
- d) any unusual features noted during the determination.

FOR BIS USE ONLY

1) See footnote on page 1.

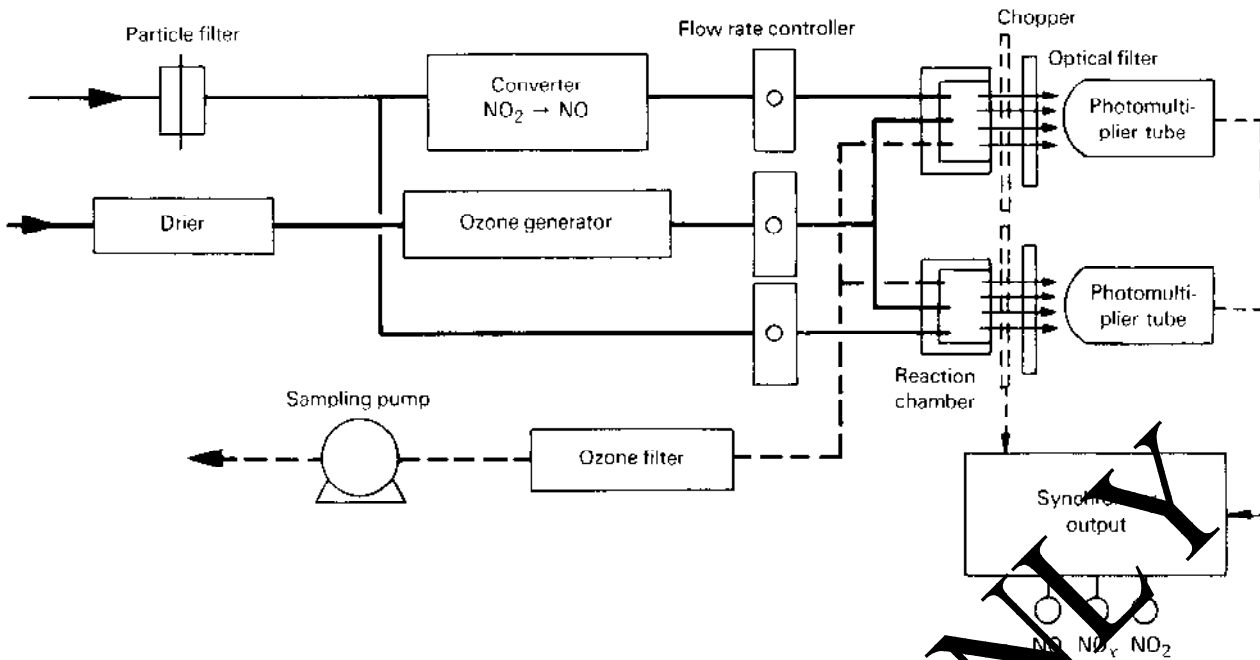

Figure 1a) – Schematic representation of a dual type chemiluminescence analyser (two reaction chambers and photomultipliers)

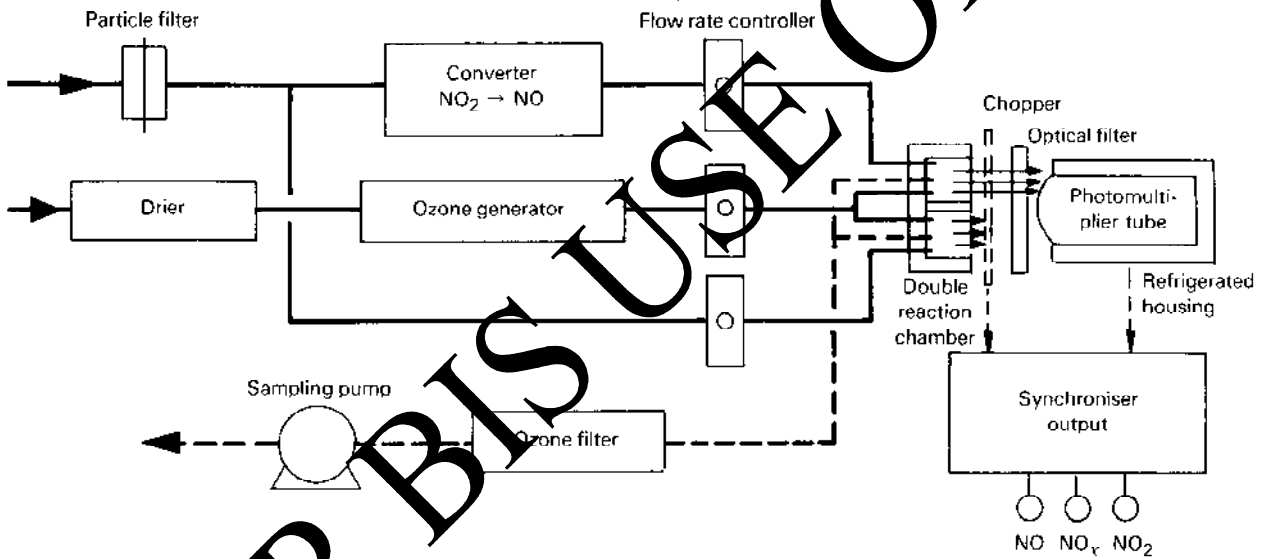

Figure 1b) – Schematic representation of a dual type chemiluminescence analyser utilizing double reaction chamber and one photomultiplier

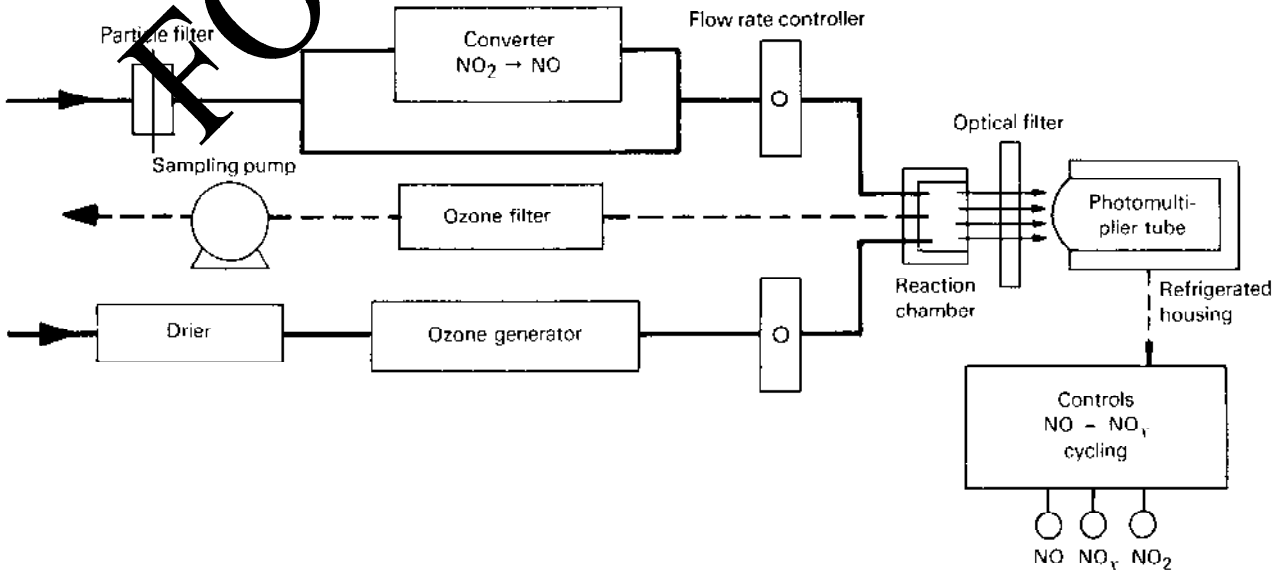

Figure 1c) – Schematic representation of a cyclic type chemiluminescence analyser

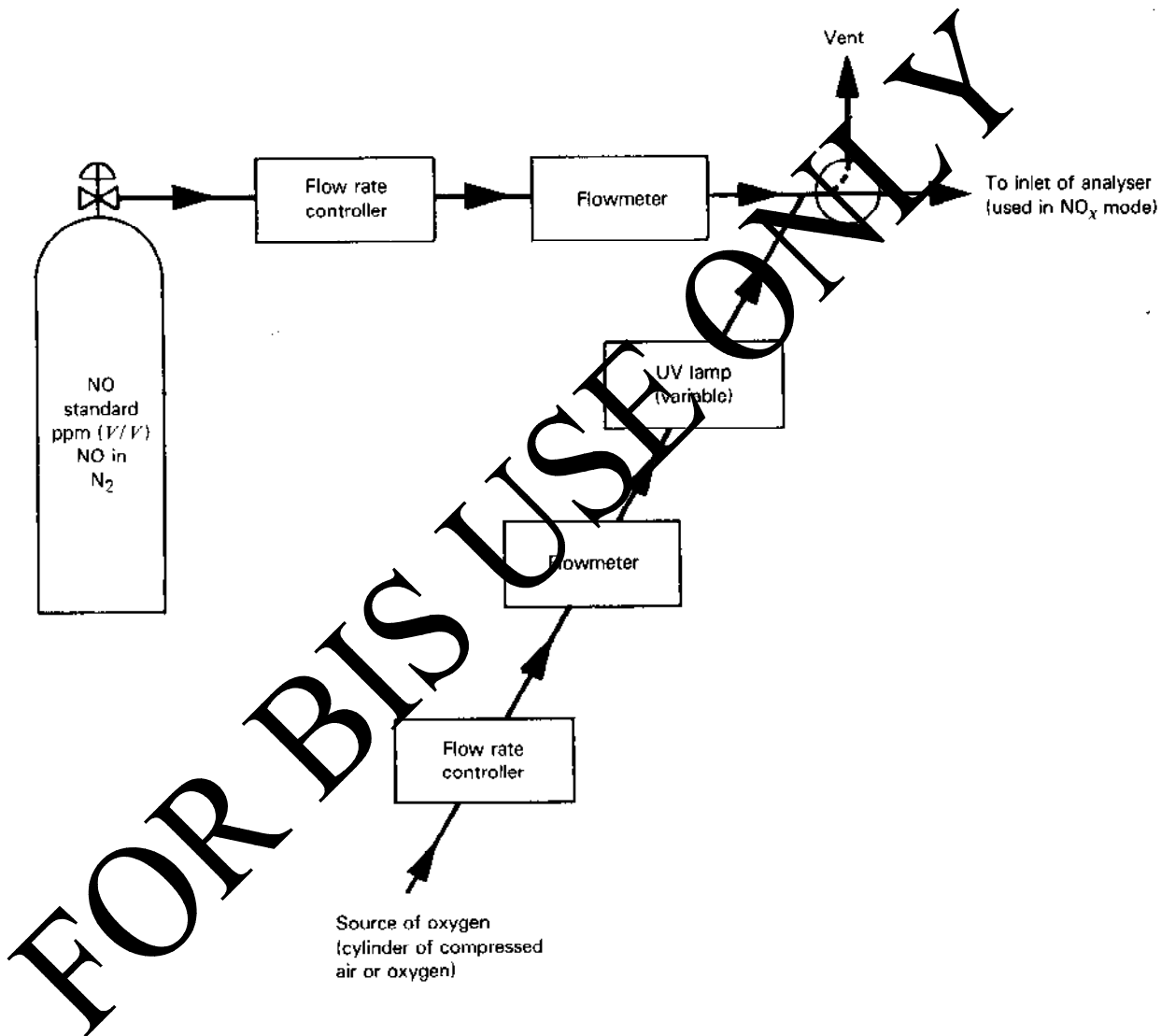

Figure 2 — Schematic representation of arrangement for checking analyser converter efficiency

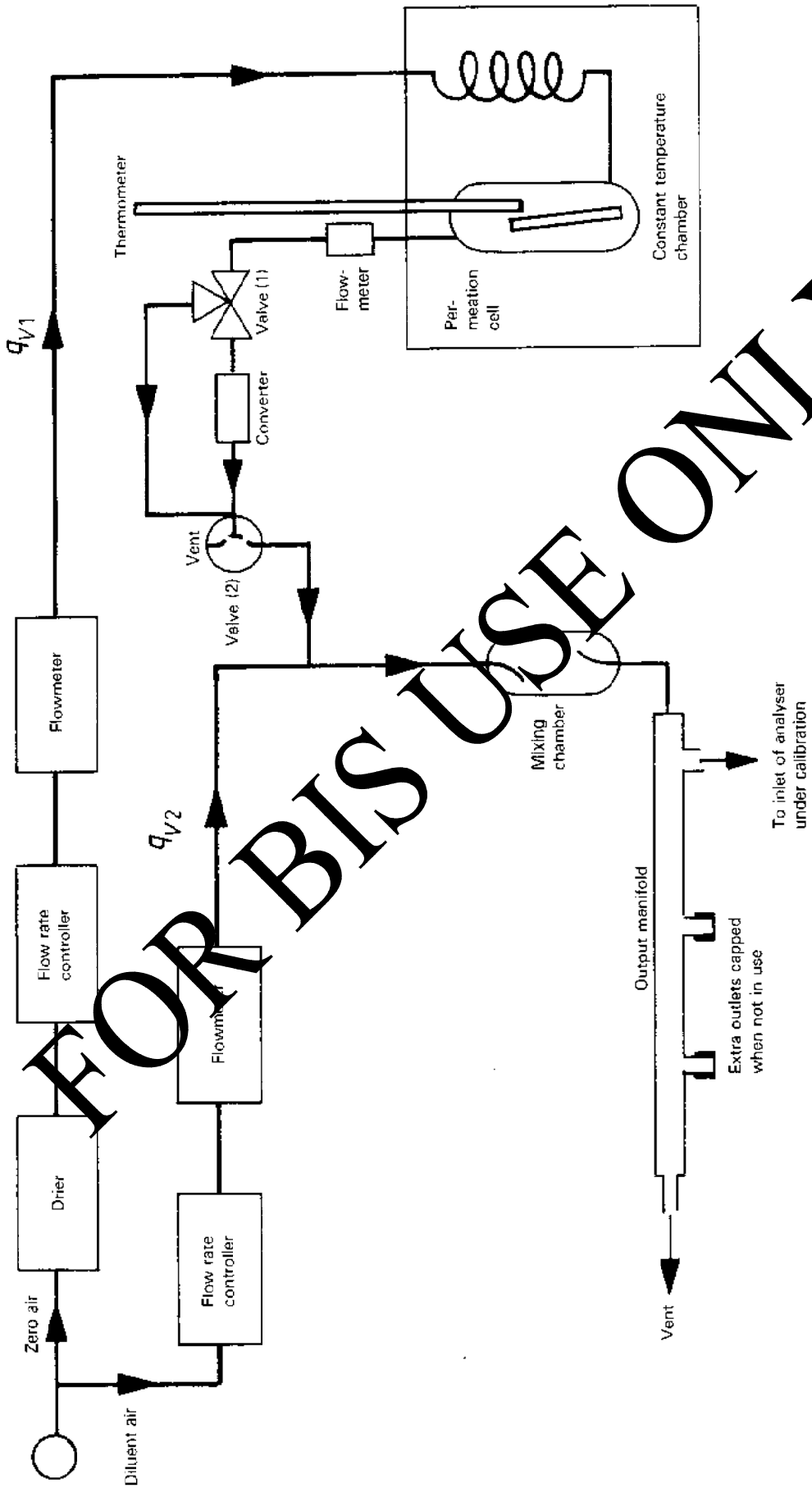

Figure 3 — Schematic representation of a typical calibration system using a nitrogen dioxide permeation cell

FOR BIS USE ONLY

Annex

Typical performance characteristics

(This annex does not form part of the standard.)

The values presented below are for general information only and are not to be interpreted as being applicable to any particular analyser.

Measurement range	Up to	12 mg/m ³ for NO
	and	18 mg/m ³ for NO ₂
Lower detection limit		10 µg/m ³ for NO 15 µg/m ³ for NO ₂
Zero drift	12 and 24 h	± 1 % full scale
Span drift	24 h	± 2 % full scale
Lag time	5 s	
Rise time	less than 20 s	(5 s time constant)
Fall time	less than 20 s	(5 s time constant)
Precision		± 1 % (at 20 % full scale) ± 2 % (at 80 % full scale)
Accuracy at ≈ 1 000 µg/m ³		± 1 % full scale
Period of unattended operation		7 d but if very low levels are being measured, then recalibration shall take place daily
Operating humidity range		0 to 95 %
Operating temperature range		10 to 45 °C

NOTE — The terms lag time, rise time, fall time, precision, accuracy, and period of unattended operation are defined in ISO 6879, *Air quality — Performance characteristics and related concepts for air quality measuring methods*.

FOR BIS USE ONLY

This page intentionally left blank