

BUREAU OF INDIAN STANDARDS

DRAFT FOR COMMENTS ONLY

(Not to be reproduced without permission of BIS or used as an Indian Standard)

भारतीय मानक मसौदा
**कार्यस्थल पर वायु — द्रव क्रोमेटोग्राफी और द्रव्यमान
स्पेक्ट्रोमीटरी के प्रयोग द्वारा आग्नेनोनाइट्रोजन
वायु में यौगिक ज्ञात करना**

भाग 2 डाइब्यूटाइलऐमीन एवं एथिल क्लोरोफार्मेट व्युत्पन्नो का
प्रयोग करके एमीन एवं एमीनोआइसोसाइनेट्स ज्ञात करना

(IS 16139(Part 2) का पहला पुनरीक्षण)

Draft Indian Standard

**Workplace Air — Determination of Organonitrogen
Compounds in Air Using Liquid Chromatography and
Mass Spectrometry**

Part 2 Amines and aminoisocyanates using dibutylamine and ethyl chloroformate
derivatives

(First Revision of IS 16139(Part 2))

(ICS 13.040.30)

Air Quality Sectional Committee, CHD 35

Last Date for Comments: 12th November 2024

Air Quality Sectional Committee, CHD 35

NATIONAL FOREWORD

(Formal clause shall be added later)

In many applications, when considering isocyanates as a workplace contaminant, there is also a need to investigate the presence of aminoisocyanates and amines. During thermal decomposition of polyurethane (PUR), not only isocyanates, but also amines and aminoisocyanates, are formed.

This standard was originally published in 2014 as an identical adoption of ISO 17734-2: 2006 under dual numbering. The first revision of this standard has been undertaken in order to adopt the latest version of ISO 17734-2 : 2013.

This part gives general guidance for the sampling and analysis of airborne amines and aminoisocyanates in workplace air. It is strongly recommended that the determination of amines and aminoisocyanates is made together with the determination of isocyanates in air, using DBA as a reagent.

This Indian standard has been published in two parts. The other part in this series is:

Part 1 Isocyanates Using Dibutylamine Derivatives

The text of ISO Standard has been approved as suitable for publication as an Indian Standard without deviations. Certain conventions and terminologies are, however, not identical to those used in Indian Standards. Attention is particularly drawn to the following:

- a) Wherever the words 'International Standard' appear referring to this standard, they should be read as 'Indian Standard'.
- b) Comma (,) has been used as a decimal marker in the International Standard, while in Indian Standards, the current practice is to use a point (.) as the decimal marker.

In this adopted standard, reference appears to certain International Standards for which Indian Standards also exist. The corresponding Indian Standards, which are to be substituted in their places, are listed below along with their degree of equivalence for the editions indicated:

<i>International Standard</i>	<i>Corresponding Indian Standard</i>	<i>Degree of Equivalence</i>
ISO 5725-2, Accuracy (trueness and precision) of measurement methods and results — Part 2: Basic method for the determination of repeatability and reproducibility of a standard measurement method	IS 15393 (Part 2) : 2021/ISO 5725-2 — Accuracy trueness and precision of measurement methods and results -- Part 2: Basic method for the determination of repeatability and reproducibility of a standard measurement method (<i>first revision</i>)	Identical with ISO 5725-2: 2019

The technical committee has reviewed the provisions of the following International Standards referred in this adopted standard and has decided that they are acceptable for use in conjunction with this standard.

<i>International Standard No</i>	<i>Title</i>
ISO 16200-1,	Workplace air quality — Sampling and analysis of volatile organic compounds by solvent desorption/gas chromatography — Part 1: Pumped sampling method

In this adopted standard, reference appears to certain International Standards where the standard atmospheric conditions to be observed are stipulated which are not applicable to tropical/subtropical countries. The applicable standard atmospheric conditions for Indian conditions are 27 °C ± 2 °C and (65 ± 5) percent, relative humidity and shall be observed while using this standard.

In reporting the result of a test or analysis made in accordance with this standard, if the final value, observed or calculated, is to be rounded off, it shall be done in accordance with IS 2: 2022 'Rules for rounding off numerical values (*second revision*)'

**Determination of organonitrogen
compounds in air using liquid
chromatography and mass
spectrometry —**

**Part 2:
Amines and aminoisocyanates
using dibutylamine and ethyl
chloroformate derivatives**

*Détermination des composés organiques azotés dans l'air par
chromatographie liquide et spectrométrie de masse —*

*Partie 2: Amines et aminoisocyanates par les dérivés de la
dibutylamine et du chloroformate d'éthyle*

FOR BIS USE ONLY



COPYRIGHT PROTECTED DOCUMENT

© ISO 2013

All rights reserved. Unless otherwise specified, no part of this publication may be reproduced or utilized otherwise in any form or by any means, electronic or mechanical, including photocopying, or posting on the internet or an intranet, without prior written permission. Permission can be requested from either ISO at the address below or ISO's member body in the country of the requester.

ISO copyright office
Case postale 56 • CH-1211 Geneva 20
Tel. + 41 22 749 01 11
Fax + 41 22 749 09 47
E-mail copyright@iso.org
Web www.iso.org

Published in Switzerland

Contents

Page

Foreword	iv
Introduction	v
1 Scope	1
2 Normative references	1
3 Principle	1
4 Reagents and materials	2
5 Standard solutions	3
5.1 Reference compounds	3
5.2 Amine and deuterium-labelled amine derivatives	3
5.3 Aminoisocyanate derivatives	4
5.4 Thermal decomposition products of polyurethane (PUR)	4
5.5 Stability of the amine and aminoisocyanate derivatives	4
6 Apparatus	5
7 Air sampling	7
7.1 Pre-sampling laboratory preparation	7
7.2 Pre-sampling field preparations	7
7.3 Collection of air samples	7
7.4 Blanks	8
7.5 Raw material	8
7.6 Shipment of samples	8
8 Laboratory sample preparation	9
8.1 Sample sequence	9
8.2 Work-up procedure	10
9 Instrumental settings	10
9.1 HPLC program (LC-MS)	10
9.2 HPLC program [LC-chemiluminescent nitrogen detector (LC-CLND)]	10
9.3 Mass spectrometer	10
10 Data handling	11
10.1 Identification	11
10.2 Calibration curves	11
10.3 Quantification	11
11 Determination of performance characteristics	11
11.1 General	11
11.2 Relevant uncertainty contributions and criteria	12
11.3 Assessment of performance characteristics (following the detailed approach in Reference [12])	12
Annex A (informative) Performance characteristics	20
Annex B (informative) Examples	22
Bibliography	27

Foreword

ISO (the International Organization for Standardization) is a worldwide federation of national standards bodies (ISO member bodies). The work of preparing International Standards is normally carried out through ISO technical committees. Each member body interested in a subject for which a technical committee has been established has the right to be represented on that committee. International organizations, governmental and non-governmental, in liaison with ISO, also take part in the work. ISO collaborates closely with the International Electrotechnical Commission (IEC) on all matters of electrotechnical standardization.

The procedures used to develop this document and those intended for its further maintenance are described in the ISO/IEC Directives, Part 1. In particular the different approval criteria needed for the different types of ISO documents should be noted. This document was drafted in accordance with the editorial rules of the ISO/IEC Directives, Part 2 (see www.iso.org/directives).

Attention is drawn to the possibility that some of the elements of this document may be the subject of patent rights. ISO shall not be held responsible for identifying any or all such patent rights. Details of any patent rights identified during the development of the document will be in the Introduction and/or on the ISO list of patent declarations received (see www.iso.org/patents).

Any trade name used in this document is information given for the convenience of users and does not constitute an endorsement.

For an explanation on the meaning of ISO specific terms and expressions related to conformity assessment, as well as information about ISO's adherence to the WTO principles in the Technical Barriers to Trade (TBT) see the following URL: Foreword - Supplementary information

The committee responsible for this document is ISO/TC 146, *Air quality*, Subcommittee SC 2, *Workplace atmospheres*.

This second edition of ISO 17734-2 cancels and replaces ISO 17734-2:2006, which has been technically revised.

ISO 17734 consists of the following parts, under the general title *Determination of organonitrogen compounds in air using liquid chromatography and mass spectrometry*:

- *Part 1: Isocyanates using dibutylamine derivatives*
- *Part 2: Amines and aminoisocyanates using dibutylamine and ethyl chloroformate derivatives*

Introduction

In many applications, when considering isocyanates as a workplace contaminant, there is also a need to investigate the presence of aminoisocyanates and amines. During thermal decomposition of polyurethane (PUR), not only isocyanates, but also amines and aminoisocyanates, are formed.^{[1][2][3][4][5][6]}

The determination of isocyanates in the work environment using DBA as a reagent has been demonstrated to be a robust method (see ISO 17734-1). Using the DBA method and derivatization with ethyl chloroformate in the following work-up procedure makes simultaneous determination of amines, aminoisocyanates, and isocyanates possible.^{[6][7]}

For quantification of amine and aminoisocyanate derivatives, reference compounds are necessary, but are only available for a few diamines. Aminoisocyanates cannot be analysed directly because they react with themselves. In this method, a nitrogen-specific detector has been used for quantification of amine and aminoisocyanate derivatives in reference solutions. This technique has been demonstrated to be a useful tool, together with MS characterization, in greatly facilitating the production of reference solutions.^[6]

FOR BIS USE ONLY

FOR BIS USE ONLY

Determination of organonitrogen compounds in air using liquid chromatography and mass spectrometry —

Part 2: Amines and aminoisocyanates using dibutylamine and ethyl chloroformate derivatives

1 Scope

This part of ISO 17734 gives general guidance for the sampling and analysis of airborne amines and aminoisocyanates in workplace air. It is strongly recommended that the determination of amines and aminoisocyanates is made together with the determination of isocyanates in air, using DBA as a reagent (see ISO 17734-1).

The method can be used for simultaneous determinations of amines, such as 4,4'-methylenediphenyldiamine (4,4'-MDA), 2,4- and 2,6-toluenediamine (2,4- and 2,6-TDA), and 1,6-hexamethylenediamine (1,6-HDA), and compounds containing both isocyanate and amine groups, such as 4,4'-methylenediphenyl aminoisocyanate (4,4'-MAI), 2,4-, 4,2-, and 2,6-toluene aminoisocyanate (2,4-, 4,2-, and 2,6-TAI), and 1,6-hexamethylene aminoisocyanate (1,6-HAI). The method is suitable for collecting amines and aminoisocyanates in both the gas and particle phases. The instrumental detection limit for the amines is about 5 nmol/sample and for the aminoisocyanate, it is about 0,3 nmol/sample. For a 15 l air sample, this corresponds to 0,4 ng·m⁻³ for TDA and 0,03 ng·m⁻³ for TAI.

2 Normative references

The following documents, in whole or in part, are normatively referenced in this document and are indispensable for its application. For dated references, only the edition cited applies. For undated references, the latest edition of the referenced document (including any amendments) applies.

ISO 16200-1, *Workplace air quality — Sampling and analysis of volatile organic compounds by solvent desorption/gas chromatography — Part 1: Pumped sampling method*

ISO 5725-2, *Accuracy (trueness and precision) of measurement methods and results — Part 2: Basic method for the determination of repeatability and reproducibility of a standard measurement method*

3 Principle

The method permits the simultaneous sampling and analysis of amines, aminoisocyanates, and isocyanates. Only amines and aminoisocyanates are discussed in this part of ISO 17734, because isocyanates are considered in ISO 17734-1.

Samples are collected by drawing a known volume of air through a midjet impinger flask followed by a filter. The impinger contains 10 ml of 0,01 mol·l⁻¹ of di-*n*-butylamine (DBA) in toluene, and the filter is a glass fibre filter with no binder. After sampling, deuterium-labelled amine-ethyl chloroformate (ET) and isocyanate-DBA derivatives (used as internal standard) are added to the sample solutions. The excess reagent and solvent are evaporated, and the samples are dissolved in acetonitrile. The samples are analysed using reversed-phase liquid chromatography (LC) and electrospray (ESP) mass spectrometric (MS) detection, monitoring positive ions. Quantification is made by quantifying selected ions.

Quantification and qualitative determinations can be performed using different LC-MS techniques. LC-CLND (chemiluminescent nitrogen detection) or, for aromatic isocyanates, aminoisocyanates, and amines, LC-UV (ultraviolet detection) can be used for the determination of higher concentrations. Reference

materials can be characterized using LC-MS/CLND. For characterization of volatile compounds, a GC-thermoionic specific detector (TSD) can also be used.

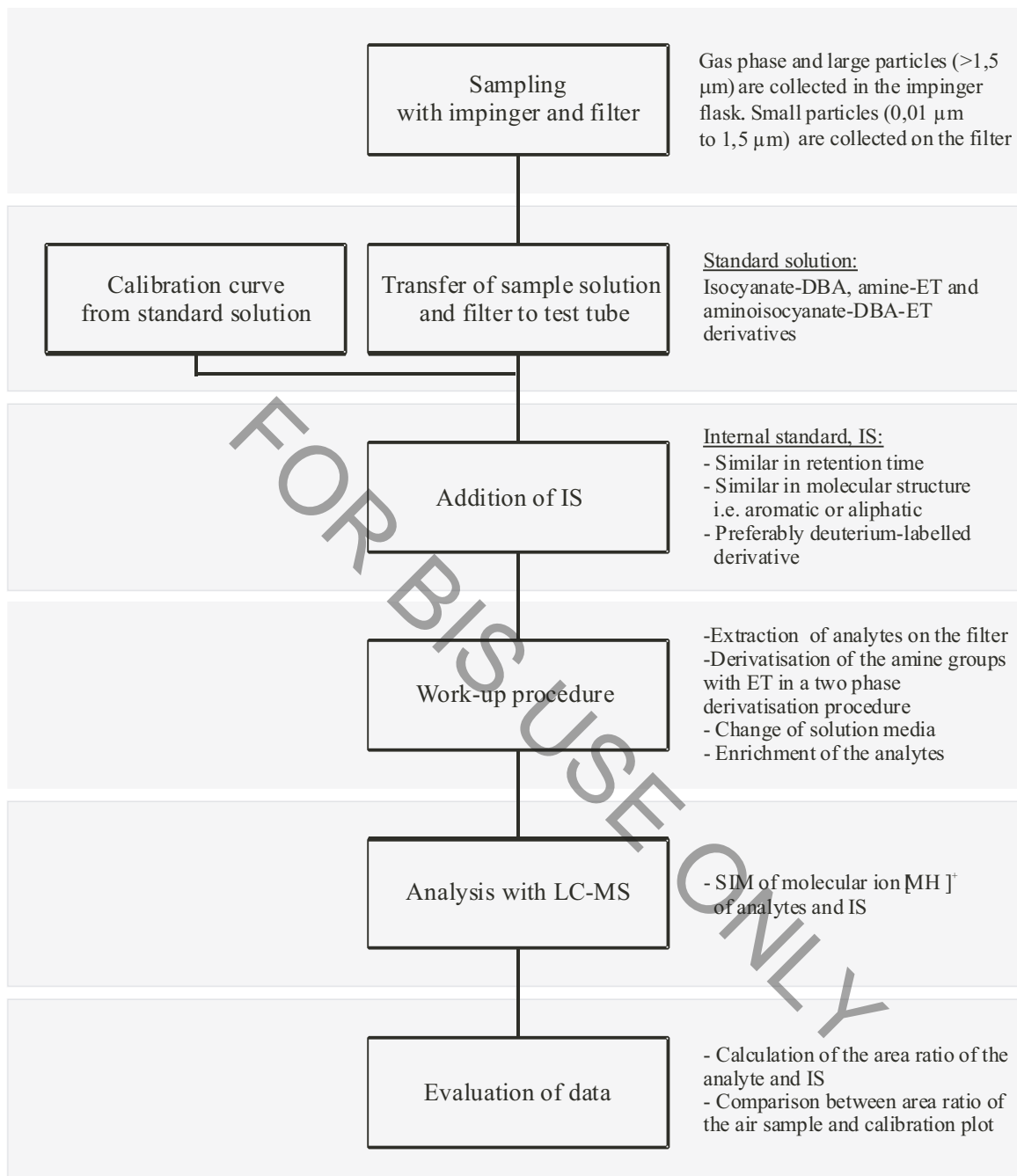

Figure 1 — Principle of the described method

4 Reagents and materials

4.1 DBA reagent.

Analytical grade di-*n*-butylamine is commercially available.

4.2 Ethyl chloroformate reagent.

Analytical grade ethyl chloroformate is commercially available.

4.3 Reagent solution.

In a 1 l volumetric flask, dilute 1,69 ml of DBA in toluene and make up to the mark. The solution is stable and no special care during storage is necessary.

4.4 Sodium hydroxide, 5 mol·l⁻¹.

Dissolve 200 g of NaOH in water in a beaker, then transfer the solution to a 1 l volumetric flask and make up to the mark.

4.5 Pyridine, analytical grade.

4.6 Solvents.

The reagent solvent, typically toluene, and other solvents, such as acetonitrile and methanol, should be of liquid chromatographic quality.

4.7 Formic acid, concentrated formic acid, analytical grade.

4.8 Ethanol, absolute, extra pure 99,5 %.

4.9 HPLC mobile phases.

4.9.1 LC-MS.

The weak mobile phase (mobile phase A) consists of water/acetonitrile (95/5 volume fraction) and 0,05 % formic acid. The strong mobile phase (mobile phase B) consists of water/acetonitrile/methanol (5/70/25 volume fraction) and 0,05 % formic acid. The mobile phases are degassed prior to use.

4.9.2 LC-CLND.

The weak mobile phase (mobile phase C) consists of water/methanol (95/5 volume fraction) and 0,05 % formic acid. The strong mobile phase (mobile phase D) consists of water/methanol (5/95 volume fraction) and 0,05 % formic acid. The mobile phases are degassed prior to use.

5 Standard solutions

5.1 Reference compounds

Reference compounds are necessary for LC-MS determination. For the commercially available amines, the ethyl chloroformate (ET) derivatives are easily prepared by direct derivatization with ET for use as calibration standards. The aminoisocyanate derivatives are prepared by reacting one of the isocyanate groups with DBA and the other group with ethanol. The mixed derivatives formed shall be characterized before use as calibration standards. Isocyanate, aminoisocyanate, and amine derivatives for compounds that are not commercially available can be made from the bulk material or from the thermal decomposition of PUR. Alternatively, standard solutions can be purchased.

5.2 Amine and deuterium-labelled amine derivatives

Calibration standards are made by spiking accurately weighed amounts (ca 0,1 mmol) of amines in 100 ml of toluene. The solution is further diluted to ca 0,01 $\mu\text{mol}\cdot\text{ml}^{-1}$. 5 ml toluene solutions are spiked with volumes of the amine solutions appropriate for the construction of a calibration curve. The work-up procedure is then performed; this is described in [8.2](#).

The procedure for the synthesis of derivatives is as follows.

- 1) Dissolve a 10 mmol aliquot of the amines and the deuterium-labelled amines in 20 ml of toluene. Thereafter, add 150 μl pyridine and 40 ml of 5 mol·l⁻¹ NaOH. Then add 1,5 ml of ET dropwise under continuous stirring.
- 2) After 10 min, separate the toluene phase.
- 3) Evaporate the reaction mixture to dryness in a rotating evaporator, and dry the residue under vacuum.

5.3 Aminoisocyanate derivatives

5.3.1 Preparation

Two procedures, A and B, are used to enrich different mixed aminoisocyanate derivatives. The isocyanate groups in, for example, 2,4-TDI have different reactivity and two different derivatives can be formed.

In procedure A: Dissolve 0,5 mmol of the isocyanates (HDI, 2,4- and 2,6-TDI, and 4,4'-MDI) in 50 ml isooctane. Add 0,5 mmol of DBA dissolved in isooctane under continuous stirring to the isocyanate solutions. After 30 min, add excess ethanol to the solutions. Allow the mixtures to react for 16 h. Evaporate the solutions to dryness and dissolve in methanol.

In procedure B: Dissolve 0,5 mmol of the isocyanate (2,4-TDI) in 50 ml of isooctane; 0,5 mmol of ethanol dissolved in isooctane is added under continuous stirring to the isocyanate solution. After 16 h, excess DBA dissolved in isooctane is added to the solution. The solution is allowed to react for 1 h. The solution is evaporated under a gentle stream of nitrogen. The residue is dissolved in methanol.

The solutions are characterized as described in [5.3.2](#).

5.3.2 Characterization

Dilute the solutions in methanol to appropriate concentrations and characterize them on the LC-MS and quantify them on the LC-CLND. This technique is nitrogen specific and any nitrogen-containing compound (e.g. caffeine) can be used as external standard. The technique is used in several applications. [\[8\]](#)[\[9\]](#)[\[10\]](#)

5.4 Thermal decomposition products of polyurethane (PUR)

5.4.1 Preparation of mixed isocyanate, amine, and aminoisocyanate derivatives

During the thermal decomposition of PUR, isocyanates, aminoisocyanates, and amines are formed that are not commercially available. PUR-based material can be thermally decomposed at appropriate temperatures. Collect emitted degradation products in impinger flasks (filters in series) containing 0,5 mol·l⁻¹ DBA and follow this by the work-up procedure described in [7.2](#). The solution is characterized as described in [5.4.2](#).

5.4.2 Characterization

Qualitative data are obtained with LC-MS. The obtained structural data together with the LC-CLND data make it possible to calculate the concentrations of different components in the solution. The characterized and diluted sample solution is used as a calibration standard for LC-MS.

5.5 Stability of the amine and aminoisocyanate derivatives

Solutions of amine-ET and ET-DBA-aminoisocyanate derivatives (MDA, 2,4- and 2,6-TDA, HDA, MAI, 2,4-, 4,2-, and 2,6-TAI, and HAI) have been found stable in toluene, acetonitrile, and methanol for 6 mo (stored in a dark fridge).

6 Apparatus

6.1 Sampler.

Sample the air with an impinger flask followed by a filter.

6.1.1 Filter.

Use a 13 mm glass fibre filter (binder free) with a pore size of 0,3 μm .

6.1.2 Filter holder.

Use a 13 mm polypropylene filter holder with luer-lock connections.

6.1.3 Midget impingers.

A midget impinger consists of a tapered inlet tube. Match the two parts so that the distance between the inlet and the receiver bottom is 1 mm to 2 mm. The filter holder is attached to the outlet of the impinger, by using an impinger with a luer-lock fitting on the outlet. Alternatively, the filter holder is attached to the outlet of the impinger by flexible tubing.

6.1.4 Sampling pump, complying to the requirements of ISO 13137, capable of maintaining the flow rate at $1 \text{ l}\cdot\text{min}^{-1}$ for impinger-filter sampling and $0,2 \text{ l}\cdot\text{min}^{-1}$ for solvent-free sampling during the sampling time.

6.1.5 Tubing.

Use rubber tubing of suitable length and of appropriate diameter to ensure a leak-proof fit to both the pump and the sampler outlet.

6.1.6 Vapour trap.

Use a vapour trap with an internal diameter of 17 mm and a length of 140 mm filled with charcoal (with a median particle size $<3 \text{ mm}$) between the sampler and the sampling pump.

6.2 Flow meter.

Use a portable flow meter capable of measuring the appropriate flow rate with acceptable accuracy.

6.3 Liquid chromatographic system.

In this method, a micro-LC system is used in order to improve the sensitivity, to minimize the maintenance on the MS, and to minimize the consumption of the mobile phase. The micro-LC system is described in the following paragraphs. If desired, this system can be replaced by a conventional LC system.

6.3.1 Autosampler.

6.3.1.1 LC-MS.

On-column focusing is performed by partially filled loops (typically 10 μl total volume) of 2 μl loop injections between 4+4 μl of 50/30/20 water/acetonitrile/methanol. Any commercially available autosampler capable of making partially filled loop injections and making sample injections of acceptable accuracy and precision can be used.

6.3.1.2 LC-CLND.

On-column focusing is performed by partially filled loops (typically 10 μl total volume) of 2 μl loop injections between 4+4 μl of 50/50 methanol/water. Any commercially available autosampler capable

of making partially filled loop injections and making sample injections of acceptable accuracy and precision can be used.

6.3.2 Pumping system (LC-MS and LC-CLND).

An HPLC pump capable of gradient elution with a flow rate of 100 $\mu\text{l}\cdot\text{min}^{-1}$ is required.

6.3.3 Analytical column (LC-MS and LC-CLND).

An HPLC column capable of separating the different analytes is required.

EXAMPLE An example of a suitable column is a PepMap® C₁₈¹⁾ (50 mm × 1,0 mm with 3 μm particles).

6.3.4 Tubing.

Use short (<40 cm) tubing with a small internal diameter (typically ID <0,1 mm).

6.3.5 Detectors.

6.3.5.1 LC-MS.

Any modern MS equipped with a robust and stable electrospray interface will have the necessary performance. The MS detection is performed with atmospheric pressure ionization, monitoring positive ions. For quantification, selected ions are monitored. Full spectra are obtained using continuous scans (typically 50 amu to 1 500 amu) for identification of unknown analytes. If wanted, a UV detector can be used in series, prior to the MS. The UV detector needs to be equipped with a micro flow cell (typically 300 nl) to minimize peak band broadening.

6.3.5.2 LC-CLND.

Use a detector which is specific for bound nitrogen.

6.4 Ultrasonic bath.

Sonication of samples is necessary to make sure that isocyanate-DBA derivatives are dissolved in the extraction solution and that the sample remaining after evaporation is properly dissolved in the added solvent.

6.5 Evaporator.

Equipment for the evaporation of the sample solvent is necessary, preferably a vacuum centrifuge. A gentle evaporation procedure is desirable since there is a risk that a tough evaporation can result in losses of the most volatile isocyanate-DBA derivatives.

6.6 Glassware, glass beakers and volumetric flasks (volumetric flasks should conform to ISO 1042).

1) PepMap® is an example of a suitable product available commercially. This information is given for the convenience of users of this part of ISO 17734 and does not constitute an endorsement by ISO of this product.

7 Air sampling

7.1 Pre-sampling laboratory preparation

7.1.1 Cleaning of sampling equipment

Impingers should be taken apart and soaked in alkaline cleaning solution for a minimum of 2 h. The upper part shall be rinsed with an alkaline cleaning solution, pure water, and finally deionized water. If the nozzle is clogged, place it in an ultrasonic bath, and then continue with the cleaning procedure. The lower part should be cleaned in a laboratory dishwasher. Both parts should be dried in an oven.

The filter cassettes and the gaskets should be immersed in ethanol in a glass beaker, sonicated for at least 15 min, rinsed with deionized water, and dried in an oven.

7.1.2 Preparation of the reagent solution and extraction solution tubes

Prepare test tubes containing 10 ml of 0,01 mol·l⁻¹ DBA as the reagent solution for the impingers. If the gas phase and the particulate phase are to be collected separately, prepare test tubes containing 10 ml of 0,01 mol·l⁻¹ DBA as the extraction solution tubes for the filters.

7.2 Pre-sampling field preparations

Assemble the sampling system with the filter cassette containing the glass fibre filter coupled to the outlet of the impinger. Transfer the reagent solution to the impinger.

Calibrate the pumps with the impinger-filter sampling system in line, using a portable flow meter. Fill the impinger with the appropriate amount of reagent solution during calibration. The sampling rate should be 1 l·min⁻¹.

7.3 Collection of air samples

7.3.1 Measurement task

In order to relate measurement results to occupational exposure limit values, take samples in the worker's breathing zone. In order to illustrate risks of being exposed, take stationary samples at every place at the work-site where isocyanates can be emitted into the air and workers are potentially exposed. It is also important to include operations that are not frequently performed, for example repair and maintenance. Differences in materials and batch-to-batch variations are factors that also should be taken into account when sampling. Collect a sufficient number of samples in order to make a representative exposure assessment.

Stationary sampling can be collected as background samples or samples reflecting the worst-case emission source. Background samples are normally collected at head height, taking into account the head height of the workers' position while carrying out the work tasks. Samples to detect emission sources or worst-case scenarios are often collected close to the process and not necessarily representative for workers' exposure but for identification of "hot spots" where substances in the process are emitted.

7.3.2 Impinger-filter sampling

Position the sampling system, either attached to the worker with the inlet in the breathing zone for personal sampling, or stationary for area sampling. Connect the pump to the sampling system, and place a charcoal vapour trap in line between the pump and the sampling system in order to protect the pump from the solvent vapour. Make sure that the equipment does not disturb the work operation, and that the impinger can be held in a vertical position during the whole sampling period.

When ready to begin sampling, switch on the pump. Record the time of sampling. At the end of the sampling period, measure the flow rate. Rinse the impinger with 0,01 mol·l⁻¹ DBA in toluene. Transfer the rinsing solution together with the impinger solution to a test tube, and immerse the glass fibre filter into

either the sampling solution or an extraction solution tube using tweezers. If the filter is transferred to an extraction solution, it is possible to determine the amount of isocyanates in the particulate phase that passes through the impinger (i.e. particles approx. 0,01 μm to 1,5 μm), separately from the gas phase and large particles (>1,5 μm) sampled in the impinger. For an illustration of the sampling procedure, see [Figure 2](#). The volume drawn through the sampler is calculated from the sampling time and the average sampling flow. The total sampling time is limited (about 30 min), unless the reagent solution is refilled during sampling.

7.4 Blanks

From every series of samples, there should be an appropriate number, e.g. 3, of field blanks, lab blanks, and chemical blanks.

Field blanks are samples that have been handled exactly like the other samples out in the field, except that no air has been drawn through. Lab blanks will be useful to identify if there is contamination, if it took place in the lab or in the field.

Chemical blanks are pure toluene with no addition of internal standard in the work-up.

7.5 Raw material

From each work-site, it is desirable to collect samples of the raw material suspected of emitting amines, aminoisocyanates, and isocyanates during the work operation. Collecting and subsequent laboratory testing of materials that are known or are suspected of emitting amines, aminoisocyanates, and isocyanates is useful for assessing the exposure. The testing can consist of extraction, heating, or other processing of the material, as similar to the original work operation as possible.

7.6 Shipment of samples

The test tubes containing the DBA-toluene samples should be shipped in individual plastic cases and preferably kept in an upright position. The sampling solution tubes should be placed well apart from any raw material collected. Regulations for shipping hazardous (dangerous) materials should be followed as appropriate.

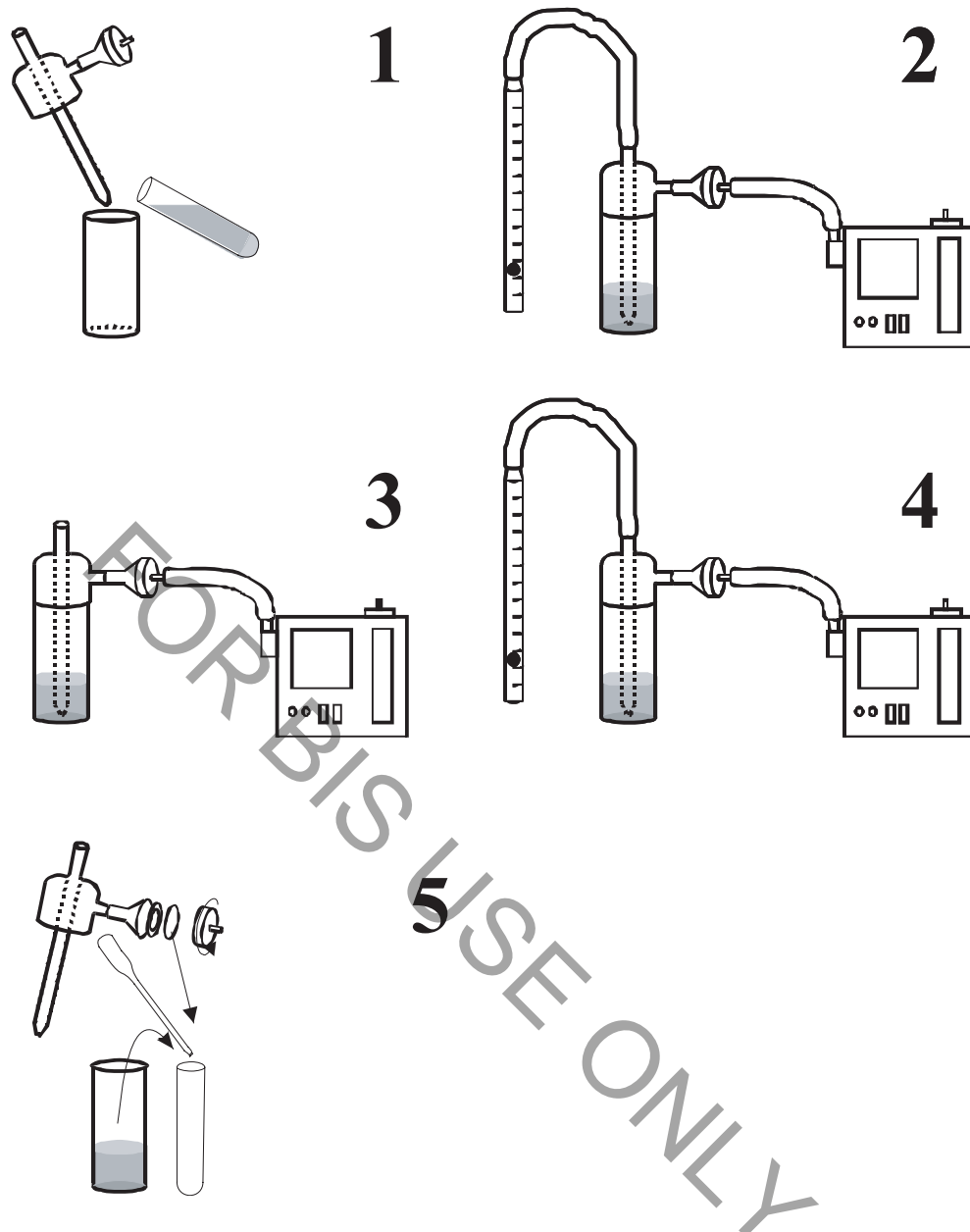
**Key**

- 1 The impinger solution is transferred to the impinger flask.
- 2 The airflow is measured and the sampling pump is calibrated to 1 l/min.
- 3 Air sampling
- 4 The airflow is measured.
- 5 The impinger solution is transferred to a test tube. The filter is either transferred to the impinger solution tube or to an extraction solution tube.

Figure 2 — Illustration of the sampling procedure

8 Laboratory sample preparation

8.1 Sample sequence

In each sample sequence (typically 50 samples), a number of samples consist of field blanks, two chemical blanks, two internal standard blanks, and an appropriate number of calibration standards. Internal

standard blanks are reagent solutions from the same batch as the reagent solution used for air sampling spiked with internal standard in the work-up procedure. Chemical blanks are pure toluene with no addition of internal standard in the work-up procedure.

8.2 Work-up procedure

For the preparation of calibration standards, aliquots of 10 ml toluene solutions, containing 0,01 mol·l⁻¹ DBA, are spiked with the amine derivatives and the aminoisocyanate derivatives to concentrations appropriate for the calibration curve. For simultaneous isocyanate determination, the isocyanate-DBA derivatives are also added to the standard solutions (see ISO 17734-1).

Upon receiving samples from the field, add deuterium-labelled amine derivatives (internal standard) to the air samples, to the standard solutions, to the field blanks, and to the internal standard blanks. For simultaneous isocyanate determination, the deuterium-labelled isocyanate derivatives are also added to the solutions (see ISO 17734-1). Place the samples in an ultrasonic bath for 15 min. If the sample solutions contain filters, place the samples in a centrifuge for 10 min (3 000 r/min). Remove the sample solutions from the filters with a pipette into new test tubes. Carbamate esters are formed by a two-phase derivatisation procedure by the addition of 3 ml of 5 mol·l⁻¹ NaOH, 10 µl pyridine, and 50 µl ethyl chloroformate. The samples are shaken for 15 min and the organic phase is separated and evaporated to dryness. The residues are dissolved in 0,5 ml acetonitrile and placed in an ultrasonic bath for 15 min.

9 Instrumental settings

9.1 HPLC program (LC-MS)

For simultaneous determination of amine, aminoisocyanate, and isocyanate derivatives, the following mobile phase composition can be used:

- flow rate: 100 µl·min⁻¹;
- 0 min to 20 min: linear gradient from 40 % mobile phase B to 80 % mobile phase B;
- 20 min to 25 min: re-equilibrate at 40 % mobile phase B.

If single or a few derivatives are to be determined, isocratic elution or gradient elution with appropriate mobile phase composition can be performed.

9.2 HPLC program [LC-chemiluminescent nitrogen detector (LC-CLND)]

For quantifying DBA derivatives in reference solutions prepared in-lab, generally at higher concentrations, the following mobile phase composition can be used:

- flow rate: 100 µl·min⁻¹;
- 0 min to 20 min: linear gradient from 40 % mobile phase D to 100 % mobile phase D;
- 20 min to 25 min: re-equilibrate at 40 % mobile phase D.

Depending on the properties of the analytes in the sample, stronger, weaker, or isocratic elution can be used.

9.3 Mass spectrometer

Settings of the MS depend greatly on the type of instrument that is used. Optimization is normally performed by the introduction of flow at 100 µl·min⁻¹ of mobile phase containing aromatic and aliphatic amine and aminoisocyanate derivatives. Optimal settings vary for the analytes and the ions to be monitored. Practical settings are not the optimum for all of the compounds to be studied.

For quantification, selected ions are monitored, e.g. the molecular ion [MH]⁺, but other typical ions can be used.

For the DBA derivatives, typical formed ions are $[MH]^+$, $[(DBA)H]^+$ ($m/z = 130$), $[(DBA)CO]^+$ ($m/z = 156$), $[MH-129]^+$, and $[MNa]^+$.

Typical ions for the amine derivatives are $[MH]^+$, $[MNa]^+$, $[M-46]^+$, and $[M-92]^+$.

Typical ions for the aminoisocyanate derivatives are $[MH]^+$, $[MNa]^+$, $[M-46]^+$, $[M-129]^+$, $[(DBA)H]^+$ ($m/z = 130$), and $[(DBA)CO]^+$ ($m/z = 156$) (see Annex B.4).

For identification of unknown isocyanates, full spectra are obtained using continuous scans (typically 50 amu to 1 500 amu).

10 Data handling

10.1 Identification

For identification, the retention times of sample peaks in the selected ion chromatograms are compared to the standards and the internal standards.

10.2 Calibration curves

The peak areas of the amine and the aminoisocyanate derivatives and the internal standard are measured, and the ratio is calculated. The ratio versus the concentration is plotted. A coefficient of correlation of 0,98 or better can be achieved. Values below 0,98 will increase the uncertainty, as calculated in 11.2.

Quadratic fit of the calibration curves can sometimes be necessary, usually because of a large dynamic range. Type and condition of used instrumentation can affect the linearity of the calibration. Quadratic calibration curves could be tolerated to some extent. However, care should be taken when using a quadratic fit so that the performance of the method is not affected.

10.3 Quantification

Quantification is accomplished by comparing the area ratio of the sample peak and internal standard to the calibration plot.

11 Determination of performance characteristics

11.1 General

The measurement of the concentration of amines, aminoisocyanates, and isocyanates in workplace air has associated with it an uncertainty that can be expressed as combined uncertainty (see EN 482[11] or Reference [12]). Thus, an uncertainty assessment has to be performed according to one or other of these definitions of uncertainty. In both cases, this consists of the determination of uncertainty contributions evaluated by means of laboratory and simulated field tests or from existing information. The values obtained of the measurement uncertainty can then be compared with pre-set criteria, for example those in EN 482[11] or those defined in national or international legislation.

11.2 Relevant uncertainty contributions and criteria

Uncertainty contribution	Quantity	Subclause	Criterion
<i>Sample volume</i>	V_{sam}	11.3.2	
Sample flow – calibration	q_{cal}		Relative uncertainty <2 %
Sample flow – variation	Δq		<5 %
Sampling time	t		Relative uncertainty <0,1 %
Knowledge of temperature during sampling	T		Relative uncertainty <4 %
Knowledge of pressure during sampling	p		Relative uncertainty <2 %
<i>Analyte mass</i>	m_{sam}	11.3.3	
Analyte stability during storage	k_{AS}		No significant difference between results of analysis of samples before and after storage
Reaction/extraction efficiency	E_{RE}		>90 % at the limit value with a relative uncertainty of <3 %
Mass of isocyanate in calibration standards	m_{CS}		Relative uncertainty <2 %
Calibration lack-of-fit	LOF		Relative residuals over the calibration range <3 %; at the limit value <2 %
Response drift between calibrations	D_R		<3 %
Analytical precision	r		<1 %
Selectivity	s		Resolution factor >1
<i>Blank level</i>	m_{BL}	11.3.4	<50 ng with a relative uncertainty of <5 %
<i>Between-laboratory variations</i>	bl		11.3.5

11.3 Assessment of performance characteristics (following the detailed approach in Reference [12])

11.3.1 Collection efficiency — relative to particle size distribution

For a complete description of the performance requirements and tests to be performed, see Reference [12].

11.3.2 Air sampling

11.3.2.1 Sampling volume

The sampled volume of air is calculated on the basis of measuring the sample flow rate before and after sampling, as specified in ISO 16200-1, using Formula (1).

$$V_{\text{sam}} = \frac{(q_{\text{start}} + q_{\text{end}})}{2} \cdot t \quad (1)$$

where

V_{sam} is the sampled volume of air (usually in millilitres);

q_{start} is the sample flow rate at the beginning of the sampling period (usually in millilitres per minute);

q_{end} is the sample flow rate at the end of the sampling period;

t is the sampling time (in minutes).

The uncertainty in the volume of air sampled is built up of contributions from

- the measurements of the flow rates before and after sampling,
- the measurement of the sampling time, and
- the variations in the flow rate during the sampling period.

It can be expressed using Formula (2).

$$\frac{u^2(V_{\text{sam}})}{V_{\text{sam}}^2} = \frac{u^2(q_{\text{start}}) + u^2(q_{\text{end}})}{(q_{\text{start}} + q_{\text{end}})^2} + \frac{u_t^2}{t^2} + \frac{u_{\text{var},q}^2}{\left[\frac{(q_{\text{start}} + q_{\text{end}})}{2}\right]^2} \quad (2)$$

where the last term represents the uncertainty contribution due to flow rate variations during sampling.

11.3.2.2 Sampling time

The sampling time, t , can be measured to within $\pm 0,5$ min. For a sampling time of 8 h, the relative uncertainty due to the measurement of t is about 0,1 % and is negligible.

11.3.2.3 Variations in flow rate during sampling

The flow rate during sampling is unknown. The uncertainty due to the variations in the flow rate during sampling can be estimated by assuming a uniform distribution using Formula (3).

$$u_{\text{var},q}^2 = \frac{(q_{\text{start}} - q_{\text{end}})^2}{12} \quad (3)$$

11.3.2.4 Conversion of sample volume to STP

For the conversion of concentrations to STP, knowledge is required of the actual mean temperature and pressure during sampling. Uncertainties in values of T and p used for conversion can be obtained from:

- actual measurements, taking into account the uncertainty in the calibration of temperature and pressure sensors used, using Formula (4):

$$u^2 = u_{\text{cal}}^2 + \frac{s_{\text{meas}}^2}{n} \quad (4)$$

where

u_{cal} is the uncertainty due to calibration of the sensor;

s_{meas} is the standard deviation of the temperature/pressure measurements;

n is the number of temperature/pressure measurements;

— knowledge of extremes of temperature and pressure during sampling, assuming these to be uniformly distributed.

For example, if the temperature extremes are known to be T_{min} and T_{max} , the uncertainty in T can be calculated using Formula (5).

$$u_T^2 = u_{\text{cal}}^2 + \frac{(T_{\text{max}} - T_{\text{min}})^2}{12} \quad (5)$$

Generally, the first term will be negligible compared to the second.

11.3.2.5 Combined uncertainty of sample volume

The above uncertainty contributions are combined to give the uncertainty in the sample volume converted to SPT using Formula (6).

$$\frac{u^2(V_{\text{sam, SPT}})}{V_{\text{sam, SPT}}^2} = \frac{u^2(V_{\text{sam}})}{V_{\text{sam}}^2} + \frac{u^2(T)}{\bar{T}^2} + \frac{u^2(p)}{\bar{p}^2} \quad (6)$$

where

\bar{T} is the mean temperature during sampling;

\bar{p} is the mean pressure during sampling.

11.3.3 Analysis

11.3.3.1 Sampled mass

The mass of isocyanate in the air samples can be expressed using Formula (7).

$$m_{\text{sam}} = \frac{m_{\text{anal}}}{E_{\text{coll}} \cdot \Delta S \cdot k_{\text{AS}} \cdot E_{\text{RE}}} \quad (7)$$

where

E_{coll} is the collection efficiency;

ΔS is the sampler variability;

k_{AS} is the analyte stability in the sample;

E_{RE} is the reaction/extraction efficiency;

m_{anal} is the uncorrected analytical mass of isocyanate in the analytical sample.

11.3.3.2 Analyte stability

The analyte stability shall be experimentally established for storage under conditions (time, temperature, environment) typical to the individual laboratory. Tests shall be performed at an isocyanate level corresponding to a concentration equivalent to the limit value.

At time $t = 0$ and time t , n samples each shall be analysed under repeatability conditions ($n = 6$). For both times, the samples shall be randomly picked from a batch of representative samples in order to minimize possible systematic concentration differences. As a test of (in)stability, a t -test will be performed (95 % confidence, two-sided). The uncertainty of the stability determination consists of contributions from

- desorption (random part of desorption efficiency),
- calibration (random part of calibration),
- analytical precision, and
- inhomogeneity of the sample batch.

As such, the contribution of the determination of k_{AS} will already be incorporated in other contributions and needs not to be taken into account.

11.3.3.3 Reaction/extraction efficiency

The reaction/extraction efficiency of isocyanate and its uncertainty are typically obtained from replicate measurements on certified reference materials (CRM) of the isocyanate or of its reaction product(s). The uncertainty due to incomplete reaction/extraction for the isocyanate level corresponding to the limit value is calculated from contributions of

- the uncertainty in the concentration of the CRM,
- the standard deviation of the mean recovery, and
- the bias between the mass of isocyanate in the CRM and the mean mass of isocyanate.

It is determined using Formula (8):

$$\frac{u_{E_{RE}}^2}{E_{RE}^2} = \frac{u_{m_{CRM}}^2}{m_{CRM}^2} + \frac{s^2(\bar{m}_{DE})}{\bar{m}_{DE}^2} + \frac{(\bar{m}_{DE} - m_{CRM})^2}{m_{CRM}^2} \quad (8)$$

where

m_{CRM} is the certified mass of isocyanate in CRM;

$u_{m_{CRM}}$ is the uncertainty in the certified mass of isocyanate in CRM;

\bar{m}_{DE} is the mean mass of isocyanate determined;

$s(\bar{m}_{DE})$ is the standard deviation of the mean of the replicate measurement results.

The latter term, representing the uncertainty due to a significant bias between certified and determined mass, can be ignored if

- the bias is statistically insignificant at the 95 % level, and
- a correction is applied for the bias.

If a CRM is not available, the material with the highest metrological quality available should be used.

11.3.3.4 Uncorrected analytical mass of compound

The uncertainty in the uncorrected analytical mass of a compound is determined by

- the uncertainty in the concentrations of the calibration standards used,
- the lack-of-fit of the calibration function,
- the drift of detector response between calibrations,
- the precision of the analysis, and
- the selectivity of the chromatographic system.

11.3.3.5 Calibration standards

The uncertainty of the concentration of isocyanate in the calibration standards used depends on the type of calibration standard used.

For calibration standards consisting of solutions in toluene or acetonitrile, the uncertainty is built up of contributions from

- the purity of isocyanate; this is generally known from manufacturer's specifications as a minimum purity p , e.g.
 - $p = 99\%$, the relative uncertainty due to impurity is given by $(100 - p)\%$; or
 - $p \geq 99\%$, the relative uncertainty can be estimated assuming a uniform distribution using Formula (9):

$$u_{\text{pur}}^2 = \frac{(100 - p)^2}{12} \quad (9)$$

- the uncertainties in the weighings of compounds and solutions, i.e. the uncertainty of the balance used.

The latter contribution is generally expressed for differential weighings using Formula (10).

$$u_{\text{weigh}}^2 = 2u_{\text{bal}}^2 \quad (10)$$

where

u_{bal} is the uncertainty of the balance used.

If this method is used for the determination of other compounds besides isocyanate, the concentration of isocyanate in the chemicals used and its uncertainty shall be established and used in the above uncertainty assessment.

11.3.3.6 Lack-of-fit of calibration function

The uncertainty due to lack-of-fit of the calibration function can be calculated for the relevant concentration (corresponding to a mass of isocyanate sampled at the limit value) from residuals of a

calibration function obtained by a least-squares linear regression weighted in the concentration of isocyanate in the calibration standard using Formula (11).

$$u_{\text{LOF}}^2 = \frac{(m_{\text{regr}} - m_{\text{std}})^2}{m_{\text{std}}^2} = \rho^2 \quad (11)$$

where

m_{regr} is the mass of isocyanate calculated from the regression equation at the level of the calibration standard corresponding corresponding closest to the mass of isocyanate representing a sample at the limit value;

m_{std} is the mass of isocyanate present in the corresponding calibration standard;

ρ is the relative residual for the particular concentration level.

NOTE The lack-of-fit of the calibration function will contribute to the uncertainty due to incomplete extraction or reaction if the latter's efficiency is significantly different from 1. In that case, irrespective of whether or not a correction for incomplete reaction/extraction is applied, the uncertainty due to lack of fit of the calibration function needs not to be taken into account in the uncertainty assessment.

11.3.3.7 Drift in detector response

The uncertainty due to response drift, D_R , can be estimated from data on the relative differences in responses between subsequent calibrations using Formula (12).

$$u_{\text{DR}}^2 = \frac{(r_n - r_{n-1})^2}{12 \left(\frac{r_n + r_{n-1}}{2} \right)^2} \quad (12)$$

where

r_n is the detector response for a calibration standard corresponding closest to the mass of isocyanate representing a sample at the limit value;

n is the number of replicate analyses.

11.3.3.8 Precision of the analysis

The uncertainty due to the (im)precision of the analysis is determined by analysis under repeatability conditions of calibration standards of the same composition; a minimum of six replicate analyses shall be performed. The uncertainty is then calculated using Formula (13).

$$u_r^2 = \frac{s_{\text{anal}}^2}{\bar{r}^2} \quad (13)$$

where

s_{anal} is the standard deviation of the replicate responses;

\bar{r} is the mean response.

In the uncertainty assessment, this contribution is already incorporated in contributions from the determination of desorption efficiency and needs not be taken into account.

11.3.3.9 Analytical selectivity

The separation system used (liquid chromatographic column, gradient program) shall be optimized in order to minimize uncertainty due to (unnoticed) co-elution of potential interferents.

The resolution, R , of the liquid chromatographic system used, given by Formula (14), shall be better than 1. In that case, the maximum uncertainty due to co-elution is 2,5 %. The typical uncertainty contribution will then be $\pm 0,7$ %.

$$R = \frac{\Delta t_r}{0,85(w_B + w_I)} \tag{14}$$

where

Δt_r is the difference in retention time of isocyanate and interferent (in seconds);

w_B is the peak width at half height of the peak (in seconds), with subscript B referring to isocyanate;

w_I is the peak width at half height of the peak (in seconds), with subscript I referring to interferent.

11.3.3.10 Combined uncertainty in the analytical mass of isocyanate

The above contributions are combined to give the uncertainty of the analytical mass of isocyanate excluding the uncertainty due to imprecision using Formula (15).

$$\frac{u^2(m_{\text{anal}})}{m_{\text{anal}}^2} = \frac{u_{\text{std}}^2}{m_{\text{std}}^2} + u_{\text{LOF}}^2 + u_{D_R}^2 + u_{\text{sel}}^2 \tag{15}$$

11.3.3.11 Combined uncertainty in the sampled mass of isocyanate

The contributions given in [11.3.3.4](#) to [11.3.3.8](#) and [11.3.3.10](#) are combined to give the uncertainty of the mass of isocyanate in the air sample using Formula (16).

$$\frac{u^2(m_{\text{sam}})}{m_{\text{sam}}^2} = \frac{u^2(m_{\text{anal}})}{m_{\text{anal}}^2} + \frac{u_{E_{RE}}^2}{E_{RE}^2} \tag{16}$$

11.3.4 Mass of compound in sample blank

The mass of isocyanate in a sample blank is determined by analysis under repeatability conditions of a series of sample blanks; a minimum of six replicate analyses shall be performed. The uncertainty is then calculated using the slope of the calibration function extrapolated to the blank response level using Formula (17).

$$u^2(m_{\text{BL}}) = \frac{s_{\text{BL}}^2}{b_{\text{BL}}} \tag{17}$$

where

s_{BL} is the standard deviation of the replicate analytical results;

b_{BL} is the slope of the calibration function at the blank response level.

If the blank response is below 3 times the noise level of the detector at the retention time of isocyanate, then the blank level and its uncertainty shall be calculated from the detector noise level using the slope of

the calibration function extrapolated to zero response assuming a uniform distribution using Formulae (18) and (19).

$$m_{\text{BL}} = \frac{3r_0}{2b_0} \quad (18)$$

$$u^2(m_{\text{BL}}) = \frac{9r_0^2}{12} \quad (19)$$

where

r_0 is the noise level;

b_0 is the slope of calibration function at zero response.

11.3.5 Between-laboratory uncertainty contributions

The procedures described above are not restrictive but allow for possible variations in approaches between laboratories. The resulting additional uncertainty contributions can be quantified by performing interlaboratory comparisons involving

- the complete measurement procedure inclusive of sampling, and
- the analytical part of the measurement procedure.

Interlaboratory comparisons shall be organized, in accordance with ISO 5725-2, using samples of sufficient homogeneity to ensure that the contribution to the between-laboratory uncertainty due to inhomogeneity is negligible. In practice, an uncertainty due to inhomogeneity of <2 % will usually be sufficient.

11.3.6 Combined uncertainty

The combined uncertainty of the isocyanate concentration in the air sampled is obtained by combination of the contributions given in Formulae (6), (14), (18), and (19) and adding the between-laboratory uncertainty (if considered appropriate) using Formula (20).

$$u_c^2(C_m) = u^2(m_{\text{sam}}) + u^2(m_{\text{BL}}) + u^2(V_{\text{sam, SPT}}) + u_{\text{bl}}^2 \quad (20)$$

where

u_{bl} is the between-laboratory uncertainty contribution.

11.3.7 Expanded uncertainty

The expanded uncertainty in C at the 95 % confidence level is obtained by multiplying $u_c(C_m)$ with a coverage factor of 2.

11.3.8 Uncertainty from performance criteria

When combining the uncertainties specified for the performance characteristics (11.2), a worst-case situation will result. The resulting combined relative uncertainty, calculated as described in 11.3.6, will be about 10 %. The expanded uncertainty will be about 20 %.

Annex A (informative)

Performance characteristics

A.1 Published uncertainty estimates

The following data on uncertainty contributions has been obtained from References [6] and [13] to [17] surveys conducted in the course of the validation of the currently described method, and estimations.

Table A.1 — Uncertainty contributions

Uncertainty contribution	Uncertainty %	Comments
<i>Sample volume</i>	4	For a 15 min air sample at a flow rate of 1 l·min ⁻¹
Sample flow – calibration	2	Calibration instrument specification
Sample flow – variation	3	Estimation
Sampling time	0,2	
Temperature during sampling	1	Estimation
Pressure during sampling	1	Estimation
<i>Analyte mass (weighing)</i>	3	The amine content in calibration standards is determined by weighing of compounds. The aminoisocyanate content is determined by LC-CLND.
<i>Analyte mass (CLND)</i>	11	
Analyte stability during storage	negligible	See References [13], [14], and [15].
Reaction/extraction efficiency	6	Estimation, no data are available
Mass of amines in calibration standards (weighing)	1	The amine content in calibration standards is determined by weighing of compounds. The aminoisocyanate content is determined by LC-CLND.[16]
Mass of aminoisocyanates in calibration standards (CLND)	10	
Calibration lack-of-fit	1	
Response drift between calibrations	negligible	Instrumental drift is corrected by using internal standards (see References [6] and [7]).
Analytical precision	2	
Selectivity	negligible	LC-MS provides highly selective determinations.
<i>Blank level</i>	negligible	
<i>Between-laboratory variations</i>	10	Estimation, no data are available

A.2 Combined uncertainty

The combined uncertainty for the amine concentration is estimated to be 12 %. The combined uncertainty for aminoisocyanate concentration is estimated to be 16 %.

A.3 Expanded uncertainty

By using a coverage factor of 2, the expanded uncertainty for the amine and aminoisocyanate concentrations is 24 % and 32 %, respectively. There will be an additional uncertainty contribution, so far not accounted for, from the collection efficiency, if collection according to a sampling convention is required.

FOR BIS USE ONLY

Annex B
(informative)

Examples

B.1 Example 1: Standard solution

See [Figure B.1](#).

FOR BIS USE ONLY

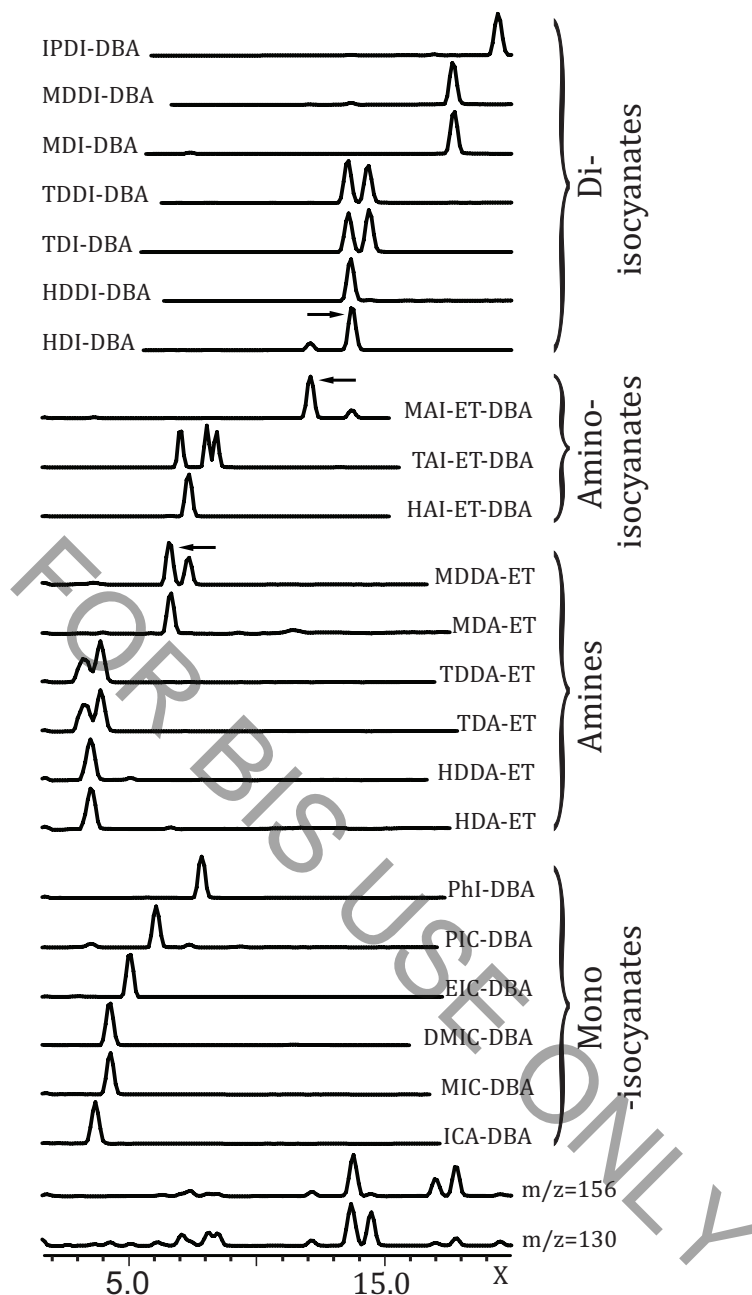

Key

X t_R in min

NOTE 1 SIR monitoring of 22 different molecular ions $[MH^+]$ and the $m/z = 130$ and 156 amu ions was performed.

NOTE 2 Peak heights in terms of retention time, t_R , were adjusted to 100 % (arbitrary scale).

Figure B.1 — LC-MS of a solution containing $0,15 \mu\text{g}\cdot\text{ml}^{-1}$ of different isocyanate-DBA, aminoisocyanate-ET-DBA, and amine-ET derivatives

B.2 Example 2: Welding in PUR-coated car metal sheets

An air sample was collected during metal active gas (MAG) welding on a PUR-coated car in a car repair shop. Sampling was performed 20 cm above the welding spot during 2 min with a sampling flow of 1 l/min.

The air sample contained the following isocyanates, aminoisocyanates, and amines (see [Figure B.2](#)):

- Isocyanic acid (ICA): 700 µg/m³;
- Methyl isocyanate (MIC): 67 µg/m³;
- Phenyl isocyanate (PhI): 11 µg/m³;
- 2,6-Toluene diisocyanate (TDI): 120 µg/m³;
- 2,4-TDI: 190 µg/m³;
- 2,6-Toluene aminoisocyanate (TAI): 540 µg/m³;
- 2,4-TAI: 390 µg/m³;
- 4,2-TAI: 820 µg/m³;
- 2,6-Toluene diamine (TDA): 67 µg/m³;
- 2,4-TDA: 270 µg/m³.

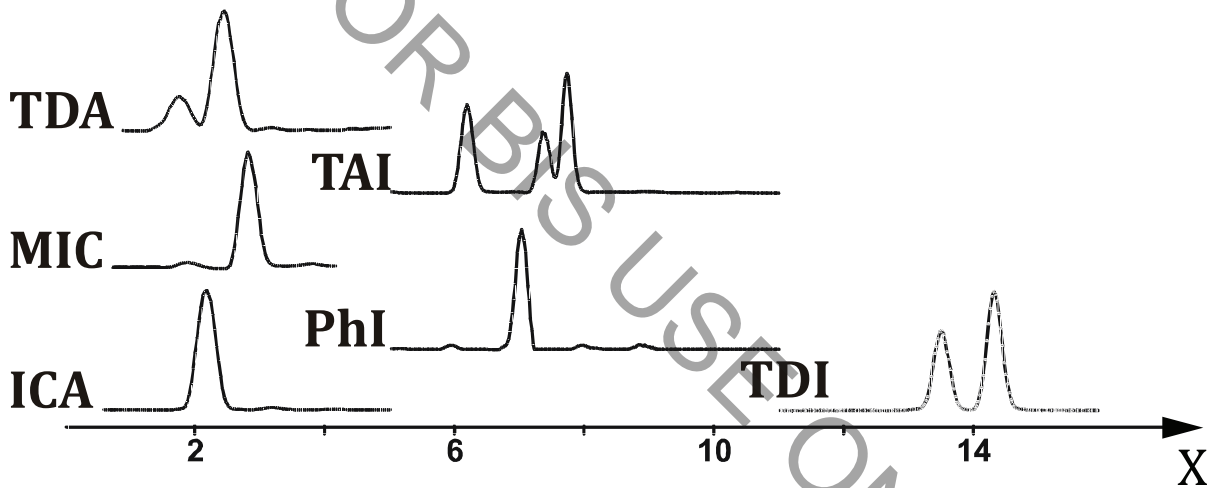

Key

X t_R , in min

NOTE Peak heights were adjusted to 100 % (arbitrary scale).

Figure B.2 — LC-MS-SIR chromatogram of the air sample in terms of retention time, t_R , as described in Example 2

B.3 Example 3: Welding in PUR-insulated pipes

An air sample was collected during outdoor welding in district heating pipes, insulated with MDI-based PUR foam. Two pipes were joined together, and before welding, the foam was removed approximately 20 cm from each end of the pipes. The sample was collected 20 cm to 40 cm above the welding spot close to the workers' breathing zone.

The air sample contained the following isocyanates, aminoisocyanates, and amines (see [Figure B.3](#)):

- Isocyanic acid (ICA): 870 µg/m³;

- Methyl isocyanate (MIC): 42 $\mu\text{g}/\text{m}^3$;
- Phenyl isocyanate (PhI): 42 $\mu\text{g}/\text{m}^3$;
- 4,4'-Methylenediphenyl diisocyanate (MDI): 1 100 $\mu\text{g}/\text{m}^3$;
- 2,4'-MDI: 260 $\mu\text{g}/\text{m}^3$;
- MDI-three ring: 3 $\mu\text{g}/\text{m}^3$;
- Methylenediphenyl diamine (MDA): 120 $\mu\text{g}/\text{m}^3$;
- Methylenediphenyl aminoisocyanate (MAI): 720 $\mu\text{g}/\text{m}^3$.

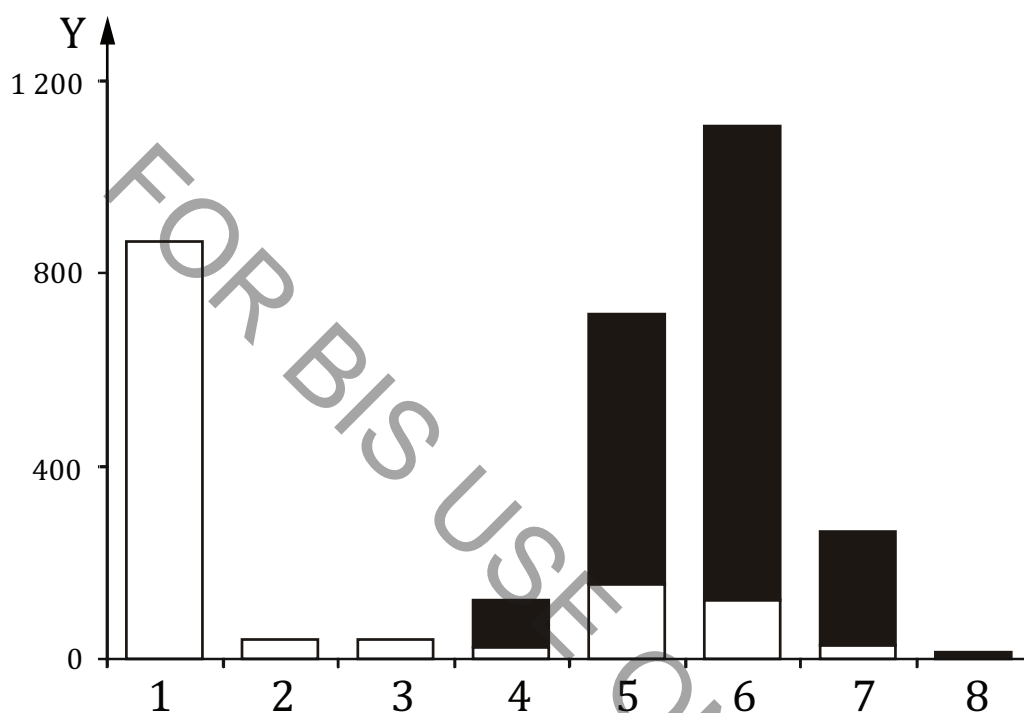

Key

Y C, in $\mu\text{g}/\text{m}^3$

- 1 Isocyanic acid (ICA)
- 2 Methyl isocyanate (MIC)
- 3 Phenyl isocyanate (PhI)
- 4 Methylenediphenyl diamine (MDA)
- 5 Methylenediphenyl aminoisocyanate (MAI)
- 6 4,4'-Methylenediphenyl diisocyanate (MDI)
- 7 2,4'-MDI
- 8 MDI-three ring
- fraction collected in the impinger flask
- fraction collected on the glass fibre filter

Figure B.3 — Isocyanate, aminoisocyanate, and amine concentrations, C, in the air sample and the fractions collected in the impinger flask and on the glass fibre filter

B.4 Example 4: Mass spectra of amino-ET, aminoisocyanate-ET-DBA, and isocyanate-DBA derivatives

Mass spectrometry provided valuable information of the present compounds in a sample. Identification of the derivatives is made possible due to characteristic fragmentation patterns. For the DBA derivatives, the typical formed ions are $[MH]^+$, $[(DBA)H]^+$ ($m/z = 130$), $[(DBA)CO]^+$ ($m/z = 156$), $[MH-129]^+$, and $[MNa]^+$.

Typical ions formed for the amino-ET derivatives are $[MH]^+$, $[MNa]^+$, $[M-46]^+$, and $[M-92]^+$.

Typical ions formed for the aminoisocyanate-ET-DBA derivatives are $[MH]^+$, $[MNa]^+$, $[M-46]^+$, $[M-129]^+$, $[(DBA)H]^+$ ($m/z = 130$), and $[(DBA)CO]^+$ ($m/z = 156$) (see [Figure B.4](#)).

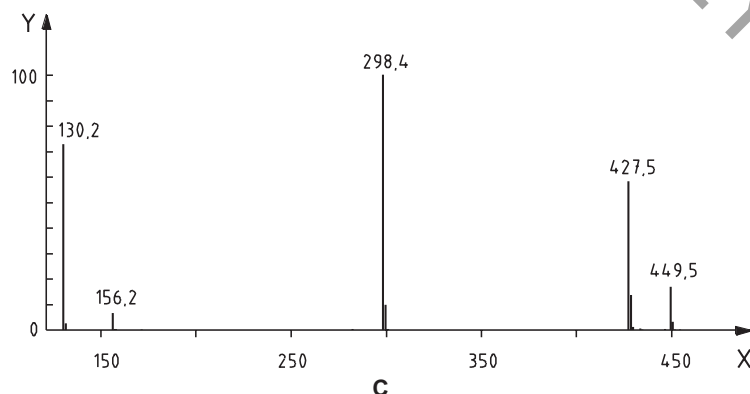
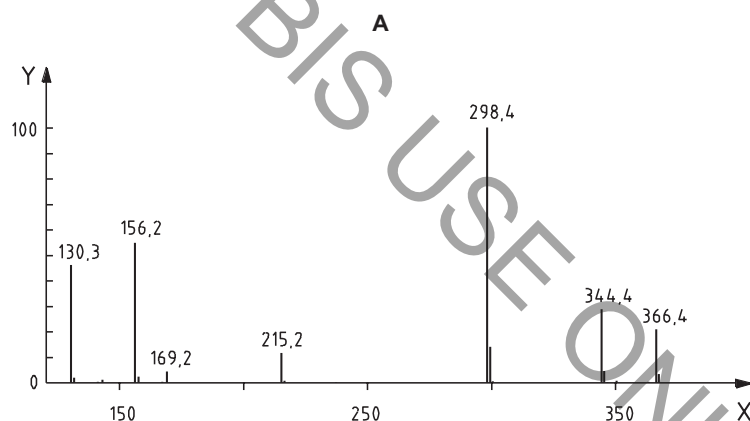
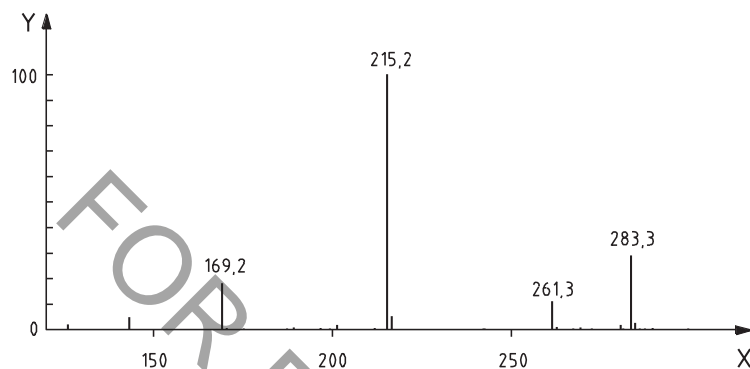

Key

X m/z

Y relative intensity (RI), in percent

Figure B.4 — Relative intensity (RI) LC-ESP mass spectra of HDA-ET (A), HAI-ET-DBA (B), and HDI-DBA (C)

Bibliography

- [1] SKARPING G., DALENEM., MATHIASSEN L. Trace analysis of airborne 1,6-hexamethylenediisocyanate and the related aminoisocyanate and diamine by glass capillary gas chromatography. *J. Chromatogr. A*. 1988, **435** pp. 453–468
- [2] TINNERBERG H., SPANNE M., DALENEM., SKARPING G. Determination of Complex Mixtures of Airborne Isocyanates and Amines — Part 3. Methylenediphenyl Diisocyanate, Methylenediphenylamino Isocyanate and Methylenediphenyldiamine and Structural Analogues after Thermal Degradation of Polyurethane. *Analyst (Lond.)*. 1997, **122** (3), pp. 275–278
- [3] TINNERBERG H., KARLSSON D., DALENE M., SKARPING G. Determination of toluene diisocyanate in air using di-*n*-butylamine and 9-N-methylaminomethyl-antracene as derivatization reagents. *J. Liq. Chrom. Rel. Technol.* 1997, **20** (14), pp. 2 207-2 219
- [4] RENMAN L., SANGÖ C., SKARPING G. Determination of isocyanate and aromatic amine emissions from thermally degraded polyurethanes in foundries. *Am. Ind. Hyg. Assoc. J.* 1986, **47** pp. 621–627
- [5] ROSENBERG C. Direct determination of isocyanates and amines as degradation products in the industrial production of polyurethane-coated wire. *Analyst (Lond.)*. 1984, **109** pp. 859–866
- [6] KARLSSON D., DAHLIN J., SKARPING G., DALENE M. Determination of isocyanates, aminocyanates and amines in air formed during the thermal degradation of polyurethane. *J. Environ. Monit.* 2002, **4** pp. 216–222
- [7] TINNERBERG H., SPANNE M., DALENE M., SKARPING G. Determination of Complex Mixtures of Airborne Isocyanates and Amines — Part 2. Toluene Diisocyanate and Aminoisocyanate and Toluenediamine After Thermal Degradation of a Toluene Diisocyanate-Polyurethane. *Analyst*. 1996, **121** (8), pp. 1 101-1 106
- [8] ASTM D4629-02, *Standard Test Method for Trace Nitrogen in Liquid Petroleum Hydrocarbons by Syringe/Inlet Oxidative Combustion and Chemiluminescence Detection*, American Society for Testing and Materials
- [9] ASTM D5762-05, *Standard Test Method for Nitrogen in Petroleum and Petroleum Products by Boat-Inlet Chemiluminescence*, American Society for Testing and Materials
- [10] ENV 12260:2003, *Water quality — Determination of nitrogen — Determination of bound nitrogen (TN_{nb}), following oxidation to nitrogen oxides*
- [11] EN 482:2012, *Workplace exposure — General requirements for the performance of procedures for the measurement of chemical agents*
- [12] EN 13205:2002, *Workplace atmospheres — Assessment of performance of instruments for measurement of airborne particle concentrations*
- [13] KARLSSON D., SPANNE M., DALENE M., SKARPING G. Determination of Complex Mixtures of Airborne Isocyanates and Amines — Part 4. Determination of Aliphatic Isocyanates as Dibutylamine Derivatives Using Liquid Chromatography and Mass Spectrometry. *Analyst (Lond.)*. 1998, **123** (1), pp. 117–123
- [14] KARLSSON D., DALENE M., SKARPING G. Determination of Complex Mixtures of Airborne Isocyanates and Amines — Part 5. Determination of low molecular weight aliphatic isocyanates as dibutylamine derivatives. *Analyst*. 1998, **123** pp. 1 507-1 512
- [15] KARLSSON D., DALENE M., SKARPING G., MARAND Å. Determination of isocyanic acid in air. *J. Environ. Monit.* 2001, **3** pp. 432–436

- [16] TAYLOR E.W., QIAN M.G., DOLLINGER G.D. Simultaneous On-Line Characterization of Small Organic Molecules Derived from Combinatorial Libraries for Identity, Quantity, and Purity by Reversed-Phase HPLC with Chemiluminescent Nitrogen, UV, and Mass Spectrometric Detection. *Anal. Chem.* 1998, **70** (16), pp. 3 339–3 347
- [17] KARLSSON D., SPANNE M., DALENE M., SKARPING G. Airborne thermal degradation products of polyurethane coatings in car repair shops. *J. Environ. Monit.* 2000, **2** (5), pp. 462–469
- [18] ISO 1042, *Laboratory glassware — One-mark volumetric flasks*
- [19] ISO 13137, *Workplace atmospheres — Pumps for personal sampling of chemical and biological agents — Requirements and test methods*
- [20] ISO 17734-1, *Determination of organonitrogen compounds in air using liquid chromatography and mass spectrometry — Part 1: Isocyanates using dibutylamine derivatives*

FOR BIS USE ONLY

FOR BIS USE ONLY

FOR BIS USE ONLY