

Settling Tanks for Ghee — Specification

(First Revision)

FOREWORD

This Indian Standard (First Revision) was adopted by the Bureau of Indian Standards, after the draft finalized by the Dairy Products and Equipment Sectional Committee had been approved by the Food and Agriculture Division Council.

Settling tanks for ghee are used in the ghee refineries and dairies to remove non-fatty solid residues from ghee by allowing the heated ghee **volume to hold**. This standard would help the fabricator and the user to obtain quality equipment meeting the desired mechanical and hygienic requirements.

Settling tanks for ghee may be of the following four types:

- a) Single-walled;
- b) Double-walled (single jacketed) with a provision for circulation of water or steam or both;
- c) Double-jacketed, insulated with a provision for circulation of water or steam or both in the inner jacket; and
- d) Double-walled, insulated.

This standard was first published in 1968. This revision is being undertaken to cover the requirements for only double-walled (single jacketed) cylindrical settling tanks for ghee, as they are most commonly used. Also the sizes of tanks widely used in ghee manufacturing have been selected in this standard. The nominal capacities as recommended in IS 2843: 1964 'Recommendations on nominal capacities for process equipment' have been adopted in sizing the settling tanks.

This standard includes the requirements for cylindrical tanks only since cylindrical tanks with conical bottoms are comparatively less costly as compared with rectangular tanks as the cost of the material and fabrication would be less. This standard is intended chiefly to cover the technical provisions relating to jacketed stainless steel ghee settling tank, and it does not include all the necessary provisions of a contract.

The word 'stainless steel' appearing at various places in this standard shall mean ISS 304 (equivalent to AISI 304) stainless steel conforming to designation X04Cr19Ni9 of IS 6911 : 2017 'Stainless steel plate, sheet and strip — Specification (**Second** Revision). Only Stainless Steel

Tungsten Inert Gas (TIG) Arc Welding using AWS ER 308L filler metal conforming to IS 2811: 1987 'Recommendations for manual tungsten inert-gas arc welding of austenitic stainless steel (first revision)' shall be done for all joints in stainless steel sheet.

For the purpose of deciding whether a particular requirement of this standard is complied with, the final value, observed or calculated, expressing the result of a test shall be rounded off in accordance with IS 2 : 1960 'Rules for rounding off numerical values (revised)'. The number of significant places retained in the rounded off value should be the same as that of the specified value in this standard.

1 SCOPE

This standard prescribes the important constructional details and dimensional requirements for double-walled (single jacketed) stainless steel settling tanks (vertical cylindrical) for ghee.

2 REFERENCES

The standards given below contain provisions which, through reference in this text, constitute provisions of this standard. At the time of publication, the editions indicated were valid. All standards are subject to revision and parties to agreements based on this standard are encouraged to investigate the possibility of applying the most recent editions of these standards.

<i>IS No.</i>	<i>Title</i>
2811 : 1987	Recommendations for manual tungsten inert-gas arc welding of austenitic stainless steel (<i>first revision</i>)
3178 : 1996	Abrasive emery grain — Specification (first revision)
3382 : 1965	Specification for stainless steel milk pipes and fittings
6911 : 2017	Stainless steel plate, sheet and strip — Specification (Second revision)

3 CAPACITY

3.1 The tanks shall be constructed in capacities of 500, 1 000, 2000, 3000, **4000** and **5000** litres.

3.1.1 The capacity is a rounded off value of the calculated capacity of the container which includes the volume of the bottom but does not include the volume of branches/nozzles.

4 MATERIAL

4.1 All the component metallic parts of tanks, which come into contact with the ghee, and the cover shall be constructed from stainless steel conforming to steel grade designation ISS 304 having Cr 18-20 percent and Ni 8-10 percent as per IS 6911. The weld areas and the deposited material shall be as corrosion resistant as the parent material.

4.2 Non-metallic material may be used for sealing, but such material shall be non-toxic, corrosion resistant, relatively non-absorbent and shall not impart any objectionable odour or flavour and dissolve in the ghee or cleaning solutions or bactericidal agents normally used.

4.3 Outer jacket and all such parts of the surfaces of the ghee settling tank, which do not come into contact with the ghee, shall also be made of steel grade designation ISS 304.

5 SHAPE AND DIMENSIONS

5.1 The cylindrical settling tanks of 500, 1000, 2000, 3000, 4000 and 5000 litres capacities shall be with conical bottom (12°) and half openable three piece covers on top. The centre portion of the cover should be fixed type. The leading recommended dimensions of vertical cylindrical tanks shall be as given in Table 1 (see also Fig. 1), However, the dimension may vary as per plant and process layout or as per mutual agreement between seller and purchaser.

6 THICKNESS OF MATERIAL

The minimum thickness of the material for tanks and cover shall be as given in Table 2.

7 FABRICATION

7.1 The typical designs of the settling tanks for ghee of different capacities are shown in Fig.1.

Table 1 Recommended Dimensions of Vertical Cylindrical Settling Tanks for Ghee

(Clause 5.1 and Fig. 1)

Capacity	Inner Diameter	Outer Diameter	Cylindrical Body Straight Height	Distance Between Legs (cc)	Height of Leg
litres	mm	mm	mm	mm	mm
(1)	(2)	(3)	(4)	(5)	(6)
500	850	1010	1230	850	1210
1 000	1200	1360	1400	1200	1230
2 000	1400	1560	1760	1400	1385
3 000	1500	1660	1750	1500	1280
4 000	1800	1960	1680	1800	1300
5 000	1800	1960	2250	1800	1300

Table 2 Thickness (minimum) of Material for Cylindrical Tanks

(Clause 6)

Capacity	Inner Shell	Outer Shell	Conical Bottom	Outer Bottom	Openable cover
litres	mm	mm	mm	mm	mm
(1)	(2)	(3)	(4)	(5)	(6)

500	2.0	2.0	2.0	2.0	2.0
1 000	2.0	2.0	2.5	2.0	2.0
2 000	2.0	2.0	2.5	2.0	2.0
3 000	2.0	2.0	3.0	2.0	2.0
4 000	2.5	2.0	3.0	2.5	2.0
5 000	2.5	2.0	3.0	2.5	2.0

7.2 All joints which come into contact with ghee shall be butt welded and finished smooth by buffing with IS Grit No. 150 (see IS 3178).

7.3 All surfaces, which come into contact with ghee, shall be free from crevices and finished smooth. All inside corners shall have a radius of not less than 25 mm.

7.4 All component parts and appurtenances having surfaces in contact with ghee shall be easily removable for cleaning or shall be readily cleanable in their places.

7.5 The tank shall be so constructed that it will not sag, buckle or prevent complete drainage.

7.6 Stainless steel flat of suitable cross-section shall be welded at the brim of the tanks from outside to strengthen the tank top edge.

8 SUPPORTS (LEGS)

8.1 The tanks shall be supported on stainless steel (AISI 304) legs (four numbers) and welded over pads provided on the bottom of tank's inner body. The pads shall be of stainless steel having **telltale/weep/vent hole for weeping of entrapped heated air/gases during welding at bottom portion.** The legs shall be of SS pipe of diameter of min size of 76 mm x 2 mm thick for tanks of capacity up to 1000 litres capacity and 90 mm x 3.0 mm thick for tanks of capacity from 2000 to 5000 liters.

8.2 The legs shall have adjustable stainless steel ball feet with provision for height adjustment upto 50 mm, as shown in **Fig. 1**.

9 COVER

Three pieces cover with a fixed central portion made of 4 mm thick stainless steel and two loose removable pieces with lifting handles made from 2 mm thick stainless steel shall be provided as shown in **Fig. 1**.

10 INLET

10.1 A vertical removable type stainless steel no foam inlet pipe connection terminating with a complete stainless steel union of 38 mm (see IS 3382) shall be provided on the top of the tanks as shown in **Fig. 1**

10.2 Air Vent

A stainless-steel air vent of size 76 mm for tanks capacity up to 2000 liters and 150 mm for capacity from 3000 to 5000 liters tanks shall be provided on top of the tank. The vent shall have sufficient free opening area (with wire mesh cover fitted) to prevent formation of partial vacuum during cleaning in place / emptying and pressure build up during filling of the tank. The vent shall be protected from ingress of vermin / insects by removable wire mesh cover. The vent shall also be protected by a hood to prevent any dirt or other particles falling from above. The hood should be bolted down.

11 OUTLET

11.1 Bottom

A 50.8 mm diameter vertical outlet with stainless steel straight through plug type flanged valve ending in complete stainless steel union (see IS 3282) shall be provided at the center of bottom conical portion. This outlet should be at a height of 650 mm from the finished floor level to facilitate placement of can under it.

11.2 Side

A 50.8 mm diameter horizontal outlet with stainless steel angular flanged valve ending in complete stainless-steel union (see IS 3382) shall be so located on the straight cylindrical body that the distance between the center line of the outlet and the line joining conical bottom to cylindrical body is appx. 100-150 mm.

11.3 The outlet shall project to at least 75 mm from the tank body.

12 SPRINKLER

12.1 Sprinkler Pipe

Sprinkler pipe of 25 mm diameter made from stainless steel shall be provided for sprinkling hot water or chilled water on the outer surface of inner shell. The sprinkler pipe shall have adequate numbers of stainless union on equal space to make it completely removable. The sprinkler pipe shall end outside in a header with two separate connections for hot and chilled water.

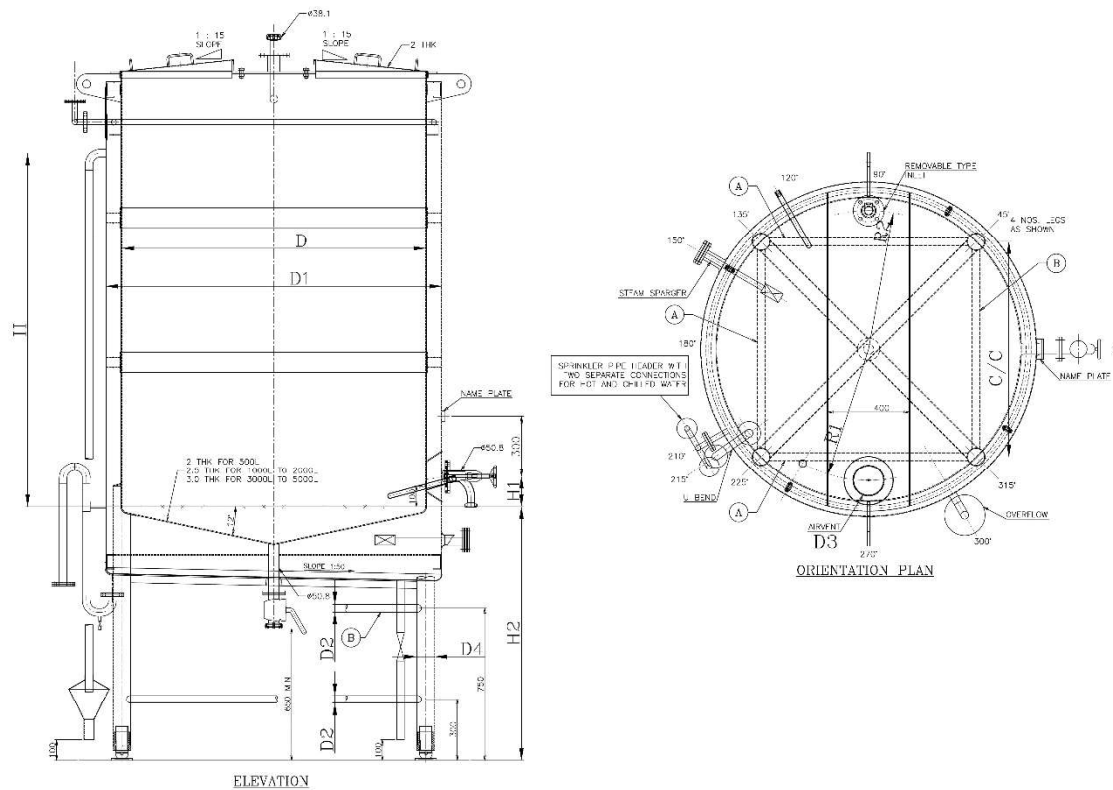

Figure: 1 JACKETED GHEE SETTLING TANK (CYLINDRICAL)

DIMENSION TABLE											
CAP. L	D mm	D1 mm	D2 mm	D3 mm	D4 mm	R1 mm	R2 mm	C/C mm	H mm	H1 mm	H2 mm
500	850	1010	φ 25	φ 76	φ 76	325	367	850	1230	150	1322
1000	1200	1360	φ 38	φ 76	φ 76	500	500	1200	1400	150	1340
2000	1400	1560	φ 38	φ 76	φ 90	600	600	1400	1760	150	1507
3000	1500	1660	φ 38	φ 150	φ 90	650	687	1500	1750	150	1250
4000	1800	1960	φ 38	φ 150	φ 90	800	820	1800	1680	150	1398
5000	1800	1960	φ 38	φ 150	φ 90	800	820	1800	2250	150	1398

12.2 Jacket Drain

A stainless steel drain of 25 NB cast steel ball valve shall be located at the bottom of the jacket (outer shell).

12.3 U-Bend

Stainless steel U-bend of diameter 38 mm shall be located at the bottom of the jacket for maintaining water level inside the jacket **which also works as a siphon.**

12.4 Steam Ejector

Stainless steel steam ejector/steam sparger shall be located near the bottom of the jacket **to maintain ghee in liquid form inside the tank by heating water in the jacket.** The connection should end outside in a flange and counter flange. The ejector has to be removable type.

12.5 Over Flow

Stainless steel overflow pipe of diameter 38 mm shall be located in the upper portion (below the sprinkler header) of the jacket as shown in Fig. 1.

~~13 DRAIN~~

~~13.1 A vertical drain connection for cylindrical tanks and horizontal drain connection for rectangular tanks shall be located on the lowest part of the bottom.~~

~~13.2 The drain shall be of a minimum size of 50.8 mm terminating with a 50.8 mm male part (see IS 3382).~~

~~13.3 The drain shall project to 75 mm from the bottom of the jacket.~~

14 LEAKAGE TESTS

14.1 The inner shell of the tank shall be tested for water tightness in the manufacturer's works after grinding and polishing the surfaces. The tank fitted with stoppers for side and bottom outlets shall not leak when filled with water up to the brim.

14.2 Water fill-up test of jacket for water tightness after grinding and polishing the surfaces. The jacket fitted with stopper for its drain shall not leak when filled with water up to the overflow.

14.3 Dye penetration test shall be conducted for all welding joints of inner shell to ensure no defect.

15 MARKING

15.1 Each settling tank shall be provided with a stainless steel nameplate of **appropriate** size ~~150 mm × 100 mm~~ fixed on a stainless steel bracket. Following particulars shall be indelibly and legibly marked on the name plate:

- a) Manufacturer's trade-mark, name and address;
- b) Manufacturer's identification;
- c) Capacity of the tank; and

d) **Month/Year** of manufacturing.

15.2 BIS Certification Marking

Each tank may also be marked with the BIS Standard Mark.

15.2.1 The use of the Standard Mark is governed by the provisions of the Bureau of Indian Standards Act, 2016 and the Rules and Regulations made thereunder. The details of conditions under which the license for the use of the Standard Mark may be granted to manufacturers or producers may be obtained from the Bureau of Indian Standards.

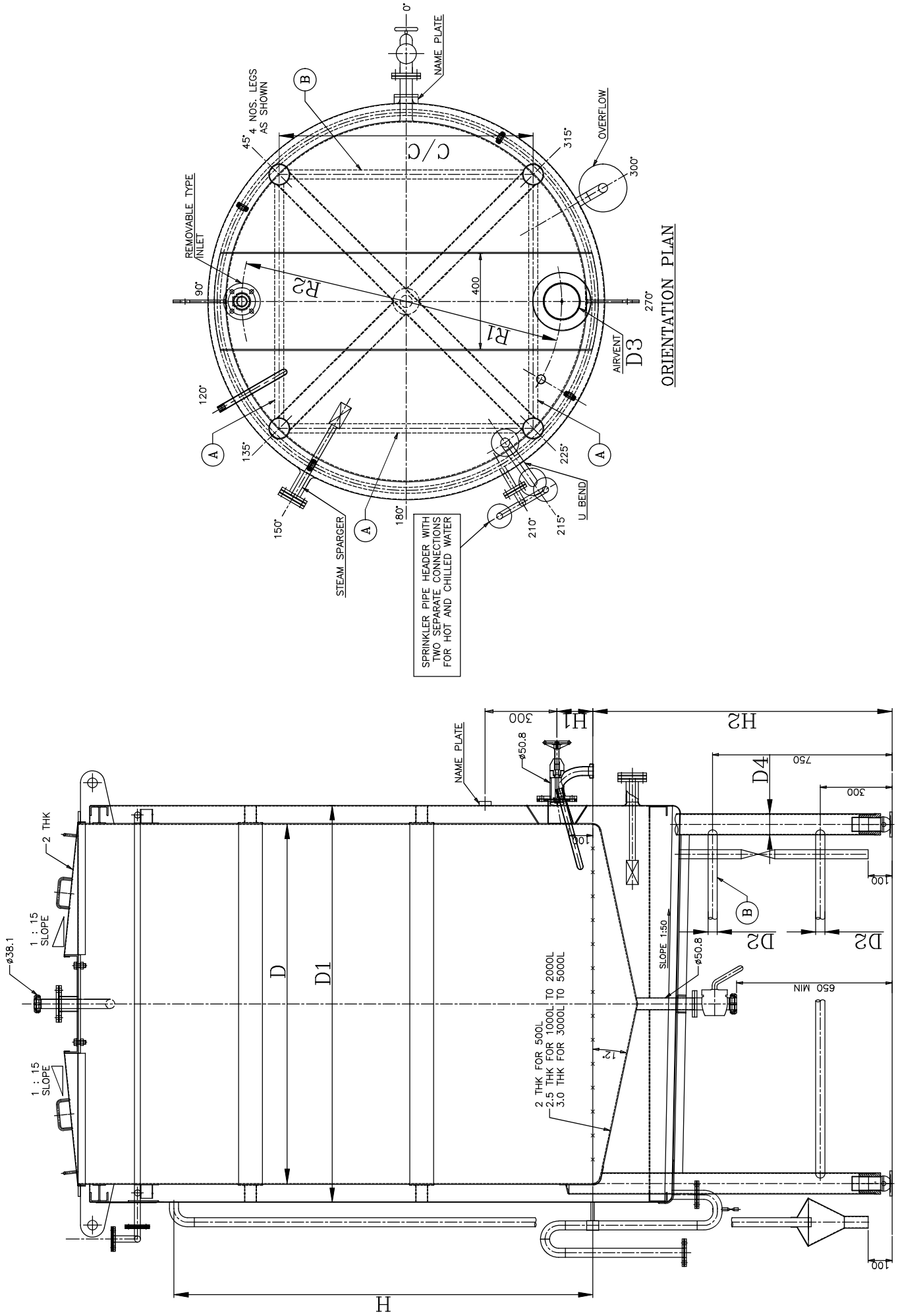

Fig. 1 JACKETED GHEE SETTLING TANK (CYLINDRICAL)

ELEVATION